



# PEGASUS

**INDUSTRIAL  
SEWING MACHINE**

## **PARTS LIST**

**FOR MODEL**

**DCR-901**

**DCR-902 DCR-903 DCR-905 DCR-909**

**DCR-915 DCR-981 DCR-985 DCR-989**

**HIGH SPEED OVERLOCK STITCH MACHINE**

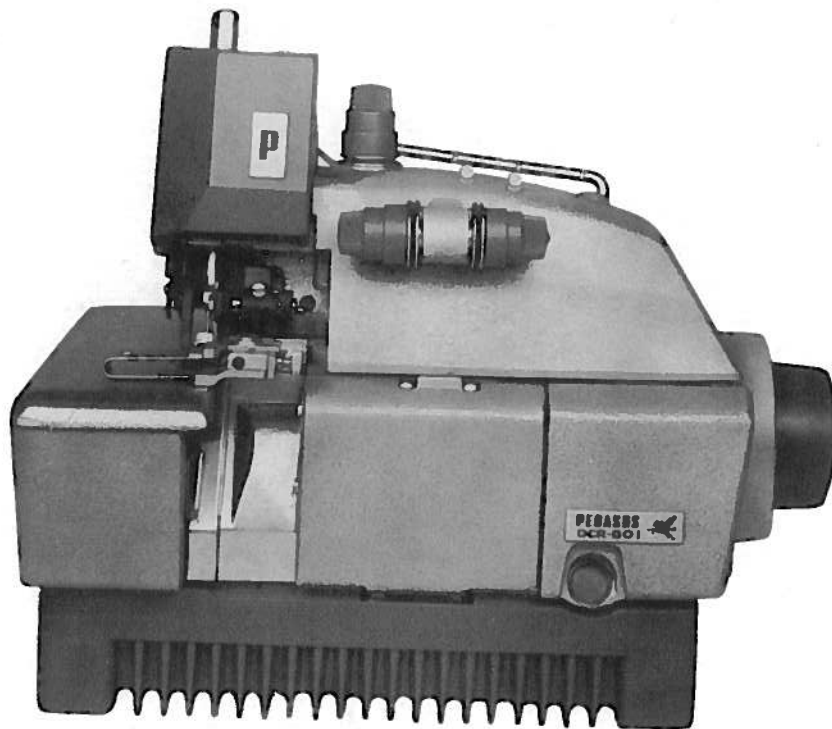

**MIMA SEWING MACHINE CO., LTD.  
PEGASUS SEWING MACHINE MFG. CO., LTD.**

**OSAKA - JAPAN - TOKYO**



## IN ORDERING PARTS

This book has been arranged to simplify ordering repair parts for, on the basis of model DCR-901, model DCR-902, 903, 905, 909, 915, 981, 985 and 989.

Various sections of the mechanisms are shown on each page. On the page opposite the illustrations will be found a listing of the parts with their reference numbers, parts numbers, names, the number of pieces required and the remarks.

At the back of this book, a numerical index of all parts is shown. This will facilitate locating the illustration and descriptions when only the part number is known.

Where parts for model DCR-901 and other DCR-900 series machines are not the same, the difference is shown in the remarks column and on the pages 24 to 29. When a part is used for all machines covered by page 2 to 23 of this list, no machine model is mentioned in the remarks column.

Parts whose numbers are marked with a circle, e. g., ○201212A, Ref. No. 35, Page 3, are also used for model DCR-801, curved needle machine.

In ordering parts from this book, the part number MUST be quoted exactly as it is shown in the second column on the page opposite the illustration. Reference number should never be used in ordering parts.

## 部品表御利用に際して

本部品表は修理用部品の利用を容易にする為に作られDCR-901型を基本型とし、DCR-902、903、905、909、915、981、985、989型の各ミシンについて機構別に各頁に収納されている。

部品図解頁（左開き）の反対頁（右開き）には参照番号、部品番号、名称、使用数量、備考欄の順に記載されている。最終頁（34—35頁）には全ての部品を網羅した索引をおき部品番号のみでその図解、名称等が容易に引出せる。

DCR-901型用と他のDCR-900シリーズ型用と異なる部品は備考欄に注記し24頁から29頁に異なる機種専用の部品を網羅している。2頁から23頁にわたり備考欄に機種名の記載なき部品はDCR-900シリーズの全機種に共通である。

○印の付されている部品番号は曲針ミシンのDCR-801型にも共通である。（例○201212A、参照番号35、3頁）。

部品御注文の際、参照番号は絶対に使用せず必ず部品番号のみを明示下さい。

## CONTENTS

## 目次

PAGE  
頁

MACHINE ARM-BED & CRANKSHAFT MECHANISM	アーム・ベッド・主軸機構	2 ~ 3
NEEDLE DRIVE MECHANISM	針棒機構	4 ~ 5
RIGHT LOOPER DRIVE MECHANISM	大ルーバー機構	6 ~ 7
LEFT LOOPER DRIVE MECHANISM	小ルーバー機構	8 ~ 9
MAIN & DIFFERENTIAL FEEDING MECHANISM	送り機構	10 ~ 11
UPPER & LOWER KNIFE MECHANISM	上・下メス機構	12 ~ 13
PRESSER FOOT & LIFTING MECHANISM	押エ機構	14 ~ 15
PUMP & LUBRICATING MECHANISM (1)	ポンプ・給油機構 (1)	16 ~ 17
PUMP & LUBRICATING MECHANISM (2)	ポンプ・給油機構 (2)	18 ~ 19
CLOTH PLATE & MISCELLANEOUS COVERS	カバー外装機構 (1)	20 ~ 21
MAIN FRAME & MISCELLANEOUS COVERS	カバー外装機構 (2)	22 ~ 23
PARTS FOR DCR-902, 903, 905, & 915 ONLY	DCR-902, 903, 905, 915型専用部品	24 ~ 25
PARTS FOR DCR-909 ONLY	DCR-909型専用部品	26 ~ 27
PARTS FOR DCR-981, 985 & 989 ONLY	DCR-981, 985, 989型専用部品	28 ~ 29
ACCESSORIES (1)	付属品 (1)	30 ~ 31
ACCESSORIES (2) FOR SEMI-SUBMERGED INSTALLATION	付属品 (2) (半沈没付用)	32 ~ 33
INDEX	索引	34 ~ 35

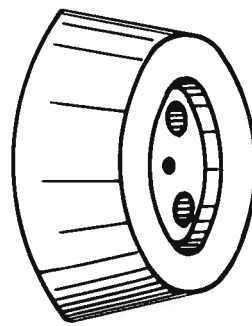
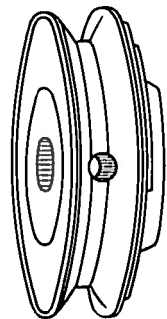
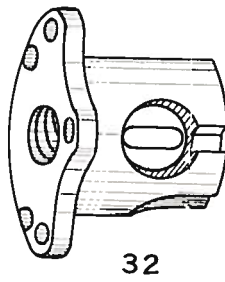
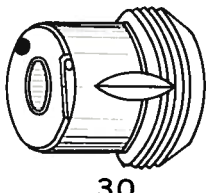
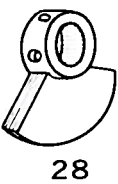
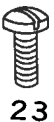
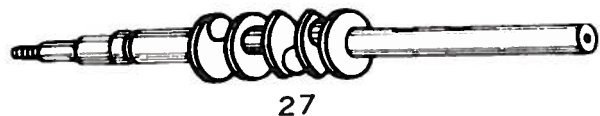
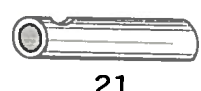
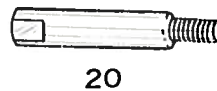
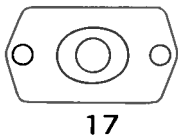
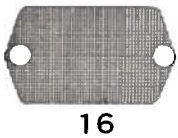
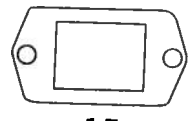
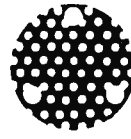
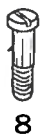
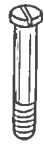
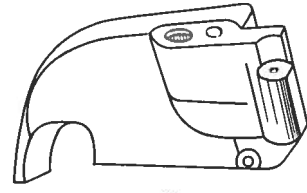
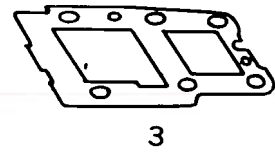
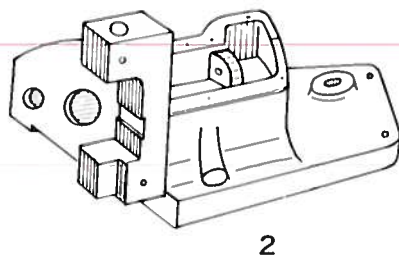
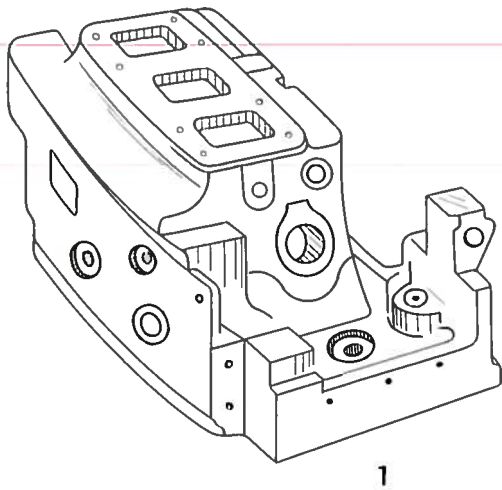

## MACHINE ARM-BED & CRANKSHAFT MECHANISM

### アーム・ベッド主軸機構

Ref. No. 参照番号	Parts No. 部品番号	Name	名称	Qt. 数量	Remarks 備考
1	202600A	Machine bed	ベッド	1	
2	202601	* arm (right)	アーム (A)	1	
3	202716	* * * gasket	* * * パッキン	1	
4	5078	* * * screw	* * * 取付ネジ	6	
5	○201002	* * * hinge pin	* * * 取付ノックピン	2	
6	202602	* arm (left)	* (B)	1	
7	5162	* * * screw (long)	* * * 止ネジ (長)	1	
8	5163	* * * * (short)	* * * * (短)	2	
9	○201002	* * * hinge pin	* * * 取付ノックピン	2	
10	○201330	Oil sight gauge	オイルゲージ	1	
11	202661	Model plate	型式板	1	DCR-901 only用
12	○201001	Oil filter screen (left)	油濾金網 (A)	1	
13	○201005	* strainer	* 金板 *	2	
14	○ 1175-2	* * * screw	* * * 止ネジ	3	
15	○202720B	Oil filter screen(front)gasket	* * * (B) パッキン	1	
16	○202662	* * * * (front)	* 金網 *	1	
17	○202663D	* * * * plate	* 金板 *	1	
18	○ 1175-2	* * * * * screw	* * * 止ネジ	2	
19	202687	Plug screw	加工穴蓋	2	
20	○202354	Machine bed bottom pin	ベッド足ピン	4	
21	201436	Oil distributing copper tube, for 202614	針棒ブッシュ給油パイプ	1	
22	201437	* * * * * retainer	* * * 止バネ	1	
23	5113	* * * * * screw	* * * 止ネジ	1	
24	201452	Spring for oil wick, for 202614	* 上給油紐バネ	1	
25	202737	Oil splash regulator, for 201011C	右大ブッシュ給油案内板	1	
26	1216	* * * * * screw	* * * 止ネジ	1	
27	202603B	Crankshaft, with 201009	クランクシャフト	1	201009との組
	○201009	* key	* キー	1	
28	○201010A	* counterweight	カウンターウエイト	1	
29	○ 5060	* * * screw	* * * 止ネジ	2	
30	○201011C	* bushing, with 201012	右大ブッシュ (組)	1	201012との組
	○201012	* * * liner	* ライナー	1	
31	○ 2317	* * * screw	* (組) 止ネジ	1	
32	202601	* flanged bushing, with 201016	左大ブッシュ (組)	1	201016との組
	201016	* * * * liner	* ライナー	1	
33	○ 5136	* * * * * screw	* * (組) 止ネジ	3	
34	○202861	* * * * * oil wick	* * * 給油フェルト	1	
35	○201212A	Crankshaft bushing (intermediate)	中間ブッシュ	1	
36	○ 2022-3	* * * * * screw	* * * 止ネジ	1	
37	○201017A	Pulley	プーリー	1	
38	○ 5080	* position screw	* 止ネジ (先有)	1	
39	○ 5081	* screw	* * (先ナシ)	1	
40	○201018B	* cap	* 蓋	1	
41	○ 5010	* * * screw	* * 止ネジ	3	
42	○202288	* * * name plate	* 銘板	1	
43	○ 5214	* * * * * screw	* * * 止ネジ	1	
44	○201021A	* thrust collar	プーリー用スラストカラー	1	
45	○202726A	* * * * * washer	* * * 座金	1	
46	○201022	* "0" ring	* "0" リング	2	

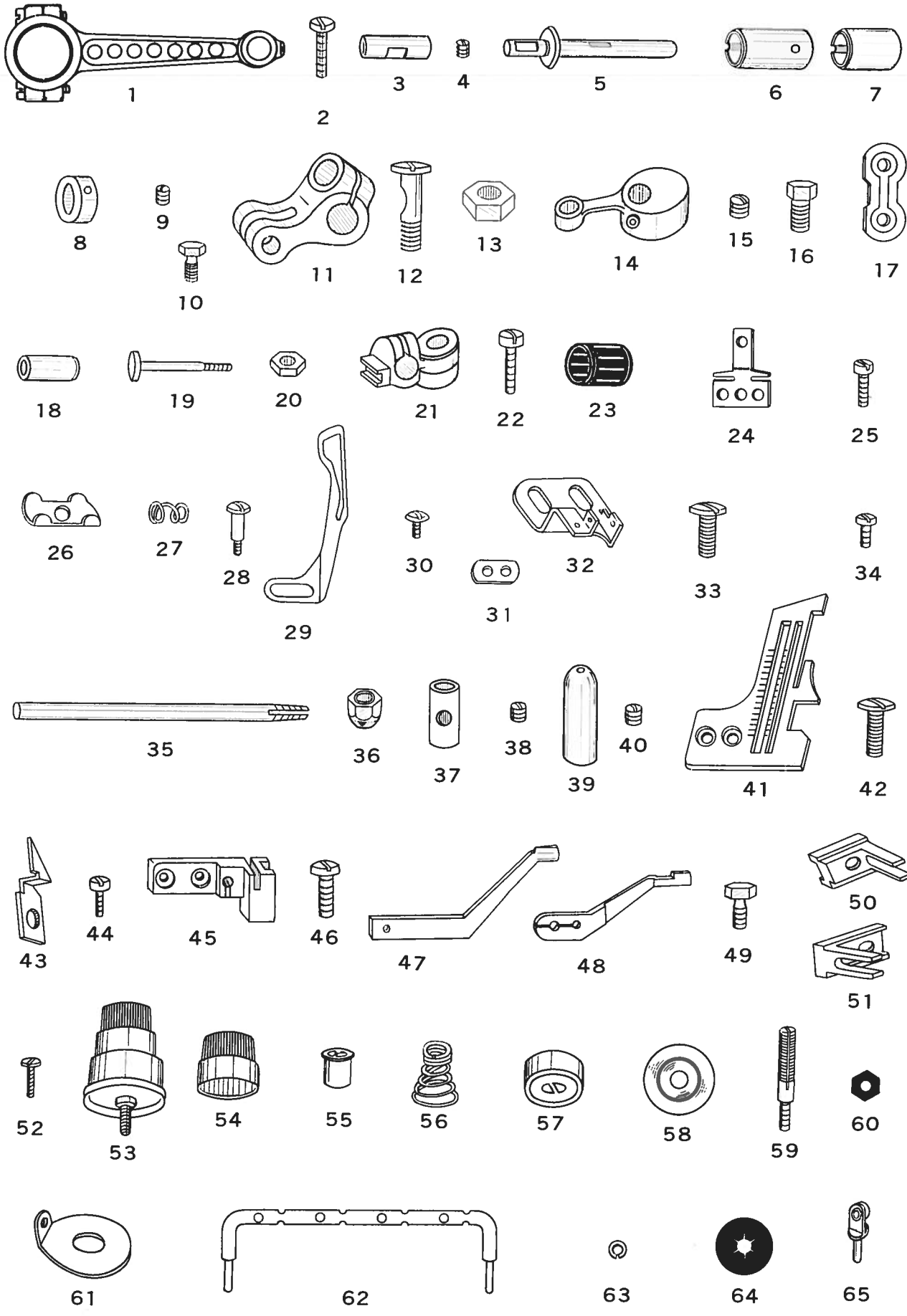

# NEEDLE DRIVE MECHANISM

## 針 棒 機 構

Ref. No. 参照番号	Parts No. 部品番号	Name	名 称	Qt. 数量	Remarks 備 考
1	202605	Needle bar connecting rod	針棒ロッド	1	
2	5263	＊ ＊ ＊ ＊ screw	＊ ＊ ＊ ＊ 蓋ネジ	2	
3	○202711A	＊ ＊ ＊ ＊ hinge pin	＊ ＊ ＊ ＊ ピン	1	
4	5264	＊ ＊ ＊ ＊ ＊ ＊ ＊ screw	＊ ＊ ＊ ＊ ＊ ＊ ＊ 止ネジ	1	
5	202606	＊ ＊ ＊ ＊ shaft	針棒クランク軸	1	
6	201356	＊ ＊ ＊ ＊ bushing (left)	＊ ＊ ＊ ＊ ＊ ＊ ＊ ブッシュ (前)	1	
7	201115A	＊ ＊ ＊ ＊ ＊ ＊ ＊ (right)	＊ ＊ ＊ ＊ ＊ ＊ ＊ (後)	1	
8	201117	＊ ＊ ＊ ＊ thrust washer	＊ ＊ ＊ ＊ ＊ ＊ ＊ スラストカラー	1	
9	1457	＊ ＊ ＊ ＊ ＊ ＊ ＊ screw	＊ ＊ ＊ ＊ ＊ ＊ ＊ 止ネジ (頭ナシ)	1	
10	5084	＊ ＊ ＊ ＊ ＊ ＊ ＊ screw	＊ ＊ ＊ ＊ ＊ ＊ ＊ (頭ツキ)	1	DCR-901, 902, 903 905, 981 & 985 only用
11	201360	＊ ＊ ＊ ＊ crank (right)	針棒後クランク	1	
12	5087	＊ ＊ ＊ ＊ ＊ ＊ ＊ screw	＊ ＊ ＊ ＊ ＊ ＊ ＊ 抱締ネジ	1	
13	5181	＊ ＊ ＊ ＊ ＊ ＊ ＊ nut	＊ ＊ ＊ ＊ ＊ ＊ ＊ ナット	1	
14	202607	＊ ＊ ＊ ＊ ＊ ＊ ＊ (left)	針棒前クランク	1	
15	2022	＊ ＊ ＊ ＊ ＊ ＊ ＊ screw	＊ ＊ ＊ ＊ ＊ ＊ ＊ 止ネジ (頭ナシ)	1	
16	2022-1	＊ ＊ ＊ ＊ ＊ ＊ ＊ screw	＊ ＊ ＊ ＊ ＊ ＊ ＊ (頭ツキ)	1	
17	202608	＊ ＊ ＊ ＊ connecting link	針棒リンク	2	
18	202609	＊ ＊ ＊ ＊ ＊ ＊ ＊ bushing	＊ ＊ ＊ ＊ ＊ ＊ ＊ ブッシュ	2	
19	5154	＊ ＊ ＊ ＊ ＊ ＊ ＊ ＊ screw	＊ ＊ ＊ ＊ ＊ ＊ ＊ ＊ 締付ネジ	2	
20	5099	＊ ＊ ＊ ＊ ＊ ＊ ＊ ＊ nut	＊ ＊ ＊ ＊ ＊ ＊ ＊ ＊ ナット	2	
21	202610	＊ ＊ ＊ ＊ ＊ ＊ ＊ bracket	針棒抱キ	1	
22	1170-3	＊ ＊ ＊ ＊ ＊ ＊ ＊ screw	＊ ＊ ＊ ＊ ＊ ＊ ＊ 止ネジ	1	
23	202611	＊ ＊ ＊ ＊ ＊ ＊ ＊ bearing	ニードルベアリング	2	
24	202705	＊ ＊ ＊ ＊ thread retainer bracket	小調子台	1	
25	5012	＊ ＊ ＊ ＊ ＊ ＊ ＊ screw	＊ ＊ ＊ ＊ ＊ ＊ ＊ 止ネジ	1	
26	200011	＊ ＊ ＊ ＊ ＊ ＊ ＊ disc	小調子皿	1	
27	200205	＊ ＊ ＊ ＊ ＊ ＊ ＊ spring	小調子バネ	1	
28	9070-2	＊ ＊ ＊ ＊ ＊ ＊ ＊ screw	＊ ＊ ＊ ＊ ＊ ＊ ＊ 止ネジ	1	
29	202706A	＊ ＊ ＊ ＊ take-up	針糸調節器	1	
30	5299	＊ ＊ ＊ ＊ ＊ ＊ ＊ screw	＊ ＊ ＊ ＊ ＊ ＊ ＊ 止ネジ	2	
31	202707	＊ ＊ ＊ ＊ ＊ ＊ ＊ washer	＊ ＊ ＊ ＊ ＊ ＊ ＊ 皿金	1	
32	202704	＊ ＊ ＊ ＊ ＊ ＊ ＊ guide	針糸道 (A)	1	
33	4003-1	＊ ＊ ＊ ＊ ＊ ＊ ＊ screw (large)	＊ ＊ ＊ ＊ ＊ ＊ ＊ 止ネジ (大)	1	
34	1196	＊ ＊ ＊ ＊ ＊ ＊ ＊ (small)	＊ ＊ ＊ ＊ ＊ ＊ ＊ (小)	1	
35	202613	＊ ＊ ＊ ＊ ＊ ＊ ＊ bar	針棒	1	DCR-901, 902, 903 905, 981 & 985 only用
36	3119	＊ ＊ ＊ ＊ ＊ ＊ ＊ clamp nut	針止ナット	1	
37	202614	＊ ＊ ＊ ＊ ＊ ＊ ＊ bar bushing	針棒ブッシュ	2	
38	1457	＊ ＊ ＊ ＊ ＊ ＊ ＊ screw	＊ ＊ ＊ ＊ ＊ ＊ ＊ 止ネジ	2	
39	202615	＊ ＊ ＊ ＊ ＊ ＊ ＊ cap cover	針棒キャップ	1	
40	1457	＊ ＊ ＊ ＊ ＊ ＊ ＊ screw	＊ ＊ ＊ ＊ ＊ ＊ ＊ 止ネジ	1	
41	○202616	＊ ＊ ＊ ＊ ＊ ＊ ＊ plate (2.0mm seam width)	針板 (縫巾 2.0mm)	1	DCR-901, 902 & 981 only用
	○202617	＊ ＊ ＊ ＊ ＊ ＊ ＊ (3.0mm seam width)	＊ ＊ ＊ ＊ ＊ ＊ ＊ ( 3.0mm)	1	
	○202618	＊ ＊ ＊ ＊ ＊ ＊ ＊ (4.0mm seam width)	＊ ＊ ＊ ＊ ＊ ＊ ＊ ( 4.0mm)	1	
42	○ 4009-1	＊ ＊ ＊ ＊ ＊ ＊ ＊ screw	針板止ネジ	2	
43	○201034A	＊ ＊ ＊ ＊ ＊ ＊ ＊ key	＊ ＊ ＊ ＊ ＊ ＊ ＊ キー	1	
44	○ 5053	＊ ＊ ＊ ＊ ＊ ＊ ＊ screw	＊ ＊ ＊ ＊ ＊ ＊ ＊ 止ネジ	1	
45	○201092A	＊ ＊ ＊ ＊ ＊ ＊ ＊ bracket	＊ ＊ ＊ ＊ ＊ ＊ ＊ 取付台	1	
46	○ 1175-2	＊ ＊ ＊ ＊ ＊ ＊ ＊ screw	＊ ＊ ＊ ＊ ＊ ＊ ＊ 止ネジ	2	
47	202474A	＊ ＊ ＊ ＊ ＊ ＊ ＊ guard (lower)	針受 (B)	1	DCR-901, 902, 903 & 981 only用
48	201453A	＊ ＊ ＊ ＊ ＊ ＊ ＊ (upper)	＊ ＊ ＊ ＊ ＊ ＊ ＊ (A)	1	
49	○ 5088	＊ ＊ ＊ ＊ ＊ ＊ ＊ screw	＊ ＊ ＊ ＊ ＊ ＊ ＊ 止ネジ	2	
50	202724	＊ ＊ ＊ ＊ ＊ ＊ ＊ (lower) bracket	＊ ＊ ＊ ＊ ＊ ＊ ＊ (B) 取付台	1	
51	○202491	＊ ＊ ＊ ＊ ＊ ＊ ＊ (upper) bracket	＊ ＊ ＊ ＊ ＊ ＊ ＊ (A) ＊	1	
52	○ 1175-3	＊ ＊ ＊ ＊ ＊ ＊ ＊ bracket screw	＊ ＊ ＊ ＊ ＊ ＊ ＊ 止ネジ	2	201035A, 202278, 201037, 201039, 201482 ＊ ＊ ＊ 5082 との組
53	○202478	＊ ＊ ＊ ＊ ＊ ＊ ＊ thread tension, complete	針糸調子 (組)	1	
54	○201035A	＊ ＊ ＊ ＊ ＊ ＊ ＊ regulating thumb nut	＊ ＊ ＊ ＊ ＊ ＊ ＊ ナット	1	
55	○202278	＊ ＊ ＊ ＊ ＊ ＊ ＊ spring bushing	＊ ＊ ＊ ＊ ＊ ＊ ＊ 棒ナット止パイプ	1	
56	○201037	＊ ＊ ＊ ＊ ＊ ＊ ＊ spring	＊ ＊ ＊ ＊ ＊ ＊ ＊ バネ	1	
57	○201039	＊ ＊ ＊ ＊ ＊ ＊ ＊ cap	＊ ＊ ＊ ＊ ＊ ＊ ＊ 受皿	1	
58	○201482	＊ ＊ ＊ ＊ ＊ ＊ ＊ disc	＊ ＊ ＊ ＊ ＊ ＊ ＊ 皿	2	
59	○ 5082	＊ ＊ ＊ ＊ ＊ ＊ ＊ screw stud	＊ ＊ ＊ ＊ ＊ ＊ ＊ 棒	1	
60	○ 3044	＊ ＊ ＊ ＊ ＊ ＊ ＊ ＊ nut	＊ ＊ ＊ ＊ ＊ ＊ ＊ 止ナット	1	
61	137106	＊ ＊ ＊ ＊ ＊ ＊ ＊ ＊ guide	＊ ＊ ＊ ＊ ＊ ＊ ＊ 台	1	
62	○201047B	Thread guide	上糸道 (大)	1	
63	○202286	＊ ＊ ＊ ＊ ＊ ＊ ＊ spring washer	＊ ＊ ＊ ＊ ＊ ＊ ＊ 止ナットバネ皿金	2	
64	○202297	＊ ＊ ＊ ＊ ＊ ＊ ＊ nut	＊ ＊ ＊ ＊ ＊ ＊ ＊ 止ナット	2	
65	○201439A	Needle thread eyelet	＊ ＊ ＊ ＊ ＊ ＊ ＊ (中)	1	

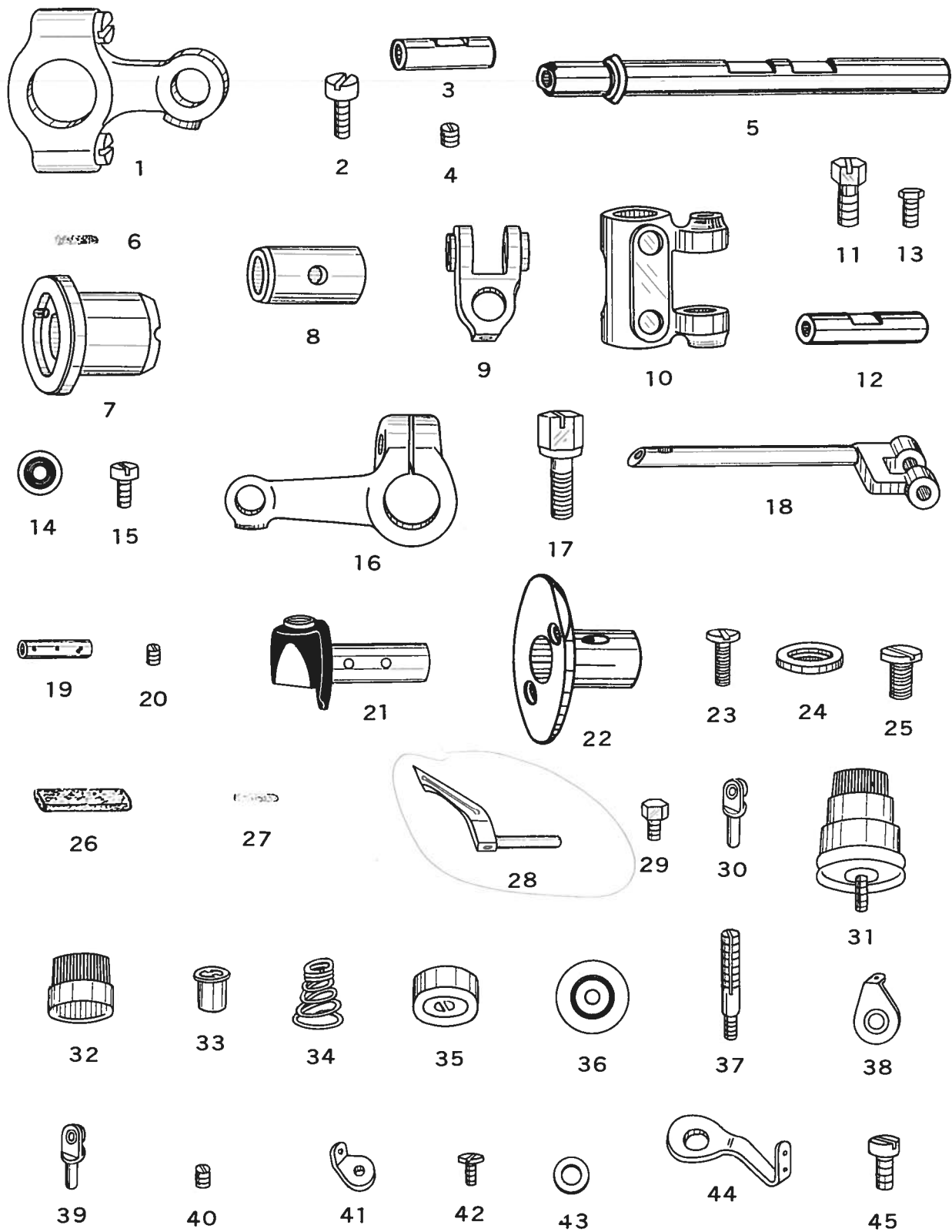



## RIGHT LOOPER DRIVE MECHANISM

### 大 ル ー パ ー 機 構

Ref. No. 参照番号	Parts No. 部品番号	Name	名 称	Qty. 数量	Remarks 備 考
1	○202619A	Right looper connecting rod	大ルーバーロッド	1	
2	○ 5002	* * * * screw	* 蓋ネジ	2	
3	○202711A	* * * * hinge pin	* ビン	1	
4	○ 1457-1	* * * * * screw	* * 止ネジ	1	
5	○202622B	* * lever shaft	大ルーバー台軸	1	
6	○202081	* * * * oil wick	* 給油フェルト	1	
7	○202623A	* * * * flanged bushing	* ブッシュ (前)	1	
8	○202713	* * * * bushing	* * (後)	1	
9	○202709A	* * * connecting rod crank	大ルーバーロッド連結棒	1	
10	○202710A	* * * lever shaft crank	大ルーバー後クランク	1	
11	○ 2022-1	* * * * * screw	* 止ネジ	2	
12	○202712A	* * * * * hinge pin	* ビン	1	
13	○ 5084	* * * * * * * screw	* * 止ネジ	1	
14	○202757	* * * * * * * washer	* * スラストワッシャー	1	
15	○ 1216	* * * * * * * * screw	* * * 止ネジ	1	
16	○202626A	* * * lever	大ルーバークランク	1	
17	○ 5219	* * * * screw	* 抱締ネジ	1	
18	○202827	* * * bar	大ルーバー台	1	
19	○202625	* * * * hinge pin	* ビン	1	
20	○ 5146	* * * * * * screw	* * 止ネジ	1	
21	○202627A	* * * * guide	* 案内	1	
22	○202628B	* * * * * flanged bushing	* * ブッシュ	1	
23	○ 1175-2	* * * * * * * screw	* * * 止ネジ	2	
24	○202629B	* * * * * thrust washer	* * スラストワッシャー	1	
25	○ 5216B	* * * * * * * screw	* * * 止ネジ	1	
26	○202473	* * * * * oil wick (large)	* * 給油フェルト (大)	1	
27	○202081	* * * * * * * (small)	* * * (小)	1	
28	202828	* * * looper	大ルーバー #4	1	DCR-901, 902, 909 981 & 989 only用
29	○ 5220	* * * * screw	* 止ネジ	1	
30	○201048A	* * * * thread eyelet (upper)	上糸道	1	
31	○202479	* * * * * tension complete	大ルーバー糸調子 (組)	1	201035A, 202278, 201068, 201039, 201482x2, 5082 との組
32	○201035A	* * * * * regulating thumb nut	* ナット	1	
33	○202278	* * * * * spring bushing	* 棒ナット止パイプ	1	
34	○201068	* * * * * spring	* バネ (弱)	1	
35	○201039	* * * * * * cap	* * 受皿	1	
36	○201482	* * * * * disc	* 皿	2	
37	○ 5082	* * * * * screw stud	* 棒	1	
38	○202849	* * * * * guide	* 台	1	
39	○201048A	* * * * * eyelet (lower)	前糸道	1	
40	○ 1459	* * * * * * * screw	* 止ネジ	1	
41	○201089	* * * * * guide	大ルーバー糸道	1	
42	○ 2921	* * * * * * * screw	* 止ネジ	1	
43	○202875	* * * * * * * washer	* * 座金	1	
44	202631A	* * * * * take-up	大ルーバー糸捌キ	1	
45	○ 5064	* * * * * * * screw	* 止ネジ	1	

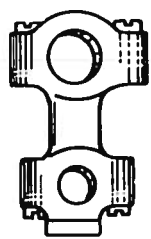

1



2



3



4



5



6



7



8

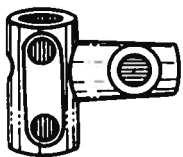

9



10



11

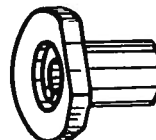

12



13



14



15

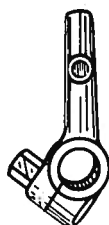

16



17

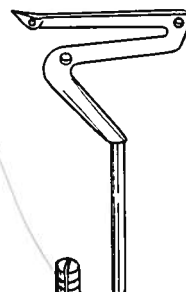

18



21



19



20



22



23



24



25



26



27



28

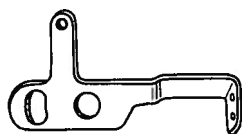

29



30

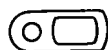

31



32



33



34



35



36



37

## LEFT LOOPER DRIVE MECHANISM

### 小 ル ー パ ー 機 構

Ref. No. 参照番号	Parts No. 部品番号	Name	名 称	Qty. 数量	Remarks 備 考
1	○201073B	Left looper connecting rod	小ルーバーロッド	1	
2	○ 1170-1	* * * * screw (small)	* 蓋ネジ (小)	2	
3	○ 5002	* * * * screw (large)	* * (大)	2	
4	○201074A	* * * * guide	* 板レ止メ	1	
5	○ 1156	* * * * * screw	* * 止ネジ	1	
6	○202286	* * * * * washer	* * * * バネ座金	1	
7	○201075	* * * * ball stud	* 球	1	
8	○ 5048	* * * * * screw	* * 止ネジ	1	
9	○201079A	* * bar crank	小ルーバークランク	1	
10	○ 5048	* * * * * screw	* * 止ネジ	2	
11	○201080	* * bar shaft	小ルーバー台軸	1	
12	○201081	* * * * flanged bushing	* ブッシュ (前)	1	
13	○ 1457	* * * * * screw	* * 止ネジ	1	
14	○201083	* * * * bushing	* * (後)	1	
15	○ 1457	* * * * * screw	* * 止ネジ	1	
16	201438A	* * bar	小ルーバー台	1	DCR-901, 902, 903 & 981 only用
17	○ 5274	* * * * screw	* 抱締ネジ	1	
18	202703	* * * * * loop	小ルーバー	1	
19	○ 5136	* * * * * screw	* * 止ネジ	1	
20	○201048A	* * * * thread eyelet (upper)	上糸道	1	
21	○202480	* * * * tension, complete	小ルーバー糸調子 (組)	1	201035A, 202278 201086, 201039 201482x2, 5082 との組
22	○201035A	* * * * * regulating thumb nut	* ナット	1	
23	○202278	* * * * * spring bushing	* 棒ナット止パイプ	1	
24	○201086	* * * * * spring	* バネ (中)	1	
25	○201039	* * * * * cap	* * 受皿	1	
26	○201482	* * * * * disc	* 皿	2	
27	○ 5082	* * * * * screw stud	* 棒	1	
28	○202849	* * * * * guide	* 台	1	
29	202633	* * * * * take-up	小ルーバー糸捌キ	1	
30	○ 2921	* * * * * screw	* * 止ネジ	1	
31	○201088	* * * * * bracket	* 取付台	1	
32	○ 1202	* * * * * * screw	* * 止ネジ	1	
33	○201048A	* * * * * eyelet (lower)	前糸道	1	
34	○ 1459	* * * * * * screw	* * 止ネジ	1	
35	○201089	* * * * * guide	小ルーバー糸道	1	
36	○ 2921	* * * * * * screw	* * 止ネジ	1	
37	○202875	* * * * * * washer	* * 座金	1	

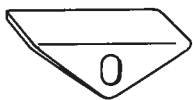
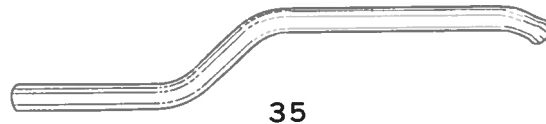
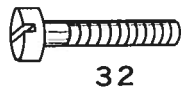
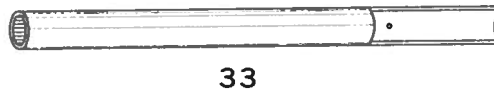
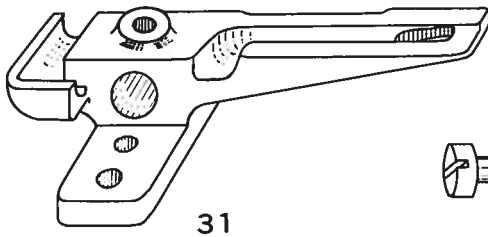
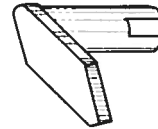
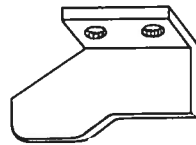
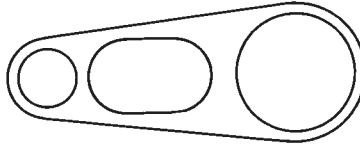
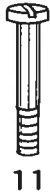
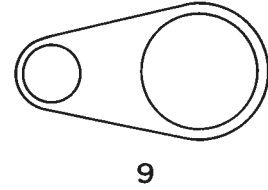
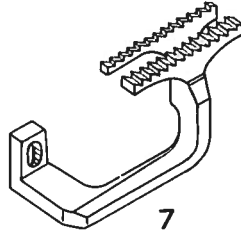
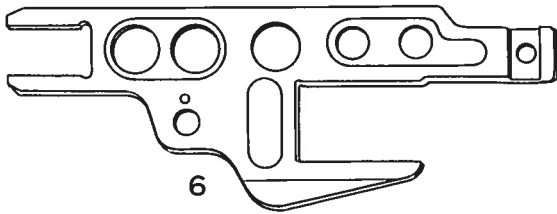
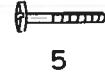
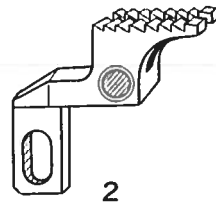
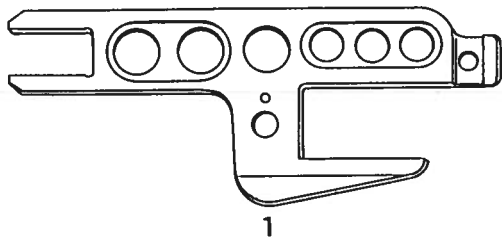

## MAIN & DIFFERENTIAL FEEDING MECHANISM

### 送　　り　　機　　構

Ref. No. 参照番号	Parts No. 部品番号	Name	名　　称	Qt. 数量	Remarks 備　　考
1	○201093A	Main feed bar	主送り台	1	
2	○201094B	＊ ＊ dog	主送り歯	1	DCR-901, 902, 905, 909 (2mm), 915, 981, 985 & 989 (2mm) only 用
3	○ 1202	＊ ＊ ＊ screw	＊ 止ネジ	1	
4	○202634	Auxiliary feed dog	補助送り歯	1	
5	○ 5086	＊ ＊ ＊ screw	＊ 止ネジ	1	
6	○201096A	Differential feed bar	差動送り台	1	
7	201378A	＊ ＊ dog	差動送り歯	1	DCR-901, 902 & 981 only 用
8	○ 1202	＊ ＊ ＊ screw	＊ 止ネジ	1	
9	○201098	Main feed connecting link	主送り連結桿	1	
10	○201099	＊ ＊ ＊ ＊ bushing	＊ ブッシュ	1	DCR-901, 902, 905, 909 981, 985 & 989 only 用
11	○201100	＊ ＊ ＊ ＊ ＊ screw	＊ ＊ 止ネジ	1	
12	○ 3044	＊ ＊ ＊ ＊ ＊ nut	＊ ＊ ＊ ナット	1	
13	○200098	＊ ＊ ＊ ＊ ＊ washer	＊ ＊ ＊ ＊ 座金	1	
14	○201101	Differential feed connecting link	差動連結桿	1	
15	○201099	＊ ＊ ＊ ＊ bushing	＊ ブッシュ	1	
16	○201100	Screw for 201099	＊ ＊ 止ネジ	1	
17	○ 3044	Nut for 201100	＊ ＊ ＊ ナット	1	
18	○200098	Washer for 3044	＊ ＊ ＊ ＊ 座金	1	
19	○201103-12	Feed eccentric #12	主送りエキセン #12	1	DCR-901, 902, 905, 909, 981, 985 & 989 only 用
20	○201103-10	＊ ＊ #10	差動送りエキセン #10	1	
21	○ 3018	＊ ＊ nut	送りエキセン止ナット	1	
22	○201101	＊ ＊ ＊ washer	＊ ＊ 座金	1	
23	○202200	Feed bar tilting adjusting pin	送り台ピン	1	
24	○ 2022	＊ ＊ ＊ ＊ ＊ screw	＊ 止ネジ	1	
25	○201106	＊ lift block	送り上下角玉	1	
26	○201107	＊ bar guide block	送り台案内角玉	2	
27	○201109	Differential feed bar guide (back)	送り台案内 (右)	1	
28	○ 1175-3	＊ ＊ ＊ ＊ ＊ screw	＊ ＊ 止ネジ	2	
29	201417	＊ ＊ ＊ ＊ (front)	＊ (前)	1	
30	2022-3	＊ ＊ ＊ ＊ ＊ screw	＊ ＊ 止ネジ	1	
31	○202201A	Main feed bar guide	＊ (左)	1	
32	○ 5095	＊ ＊ ＊ ＊ screw	＊ ＊ 止ネジ	2	
33	○201110	Oil tube for oil wick, for 201093A & 201096A	送り台給油パイプ	1	
34	○ 1435	＊ ＊ screw	＊ 止ネジ	1	
35	○202202	＊ ＊ for oil wick, for 201103	送りエキセン給油パイプ	1	
36	○202203	＊ ＊ retainer	＊ ＊ 押エ金	1	
37	○ 1196	＊ ＊ ＊ screw	＊ ＊ ＊ 止ネジ	1	

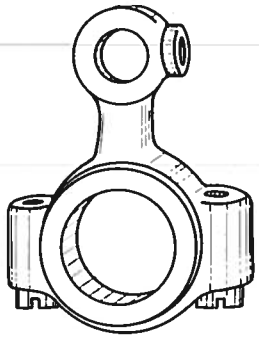

1

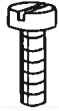

2



3



4

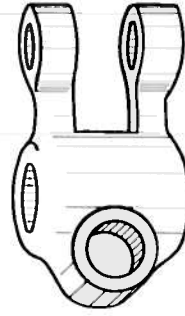

5

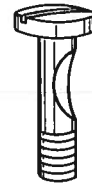

6



7

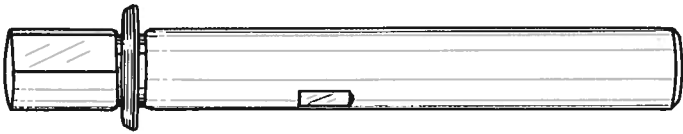

8

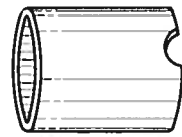

9



10

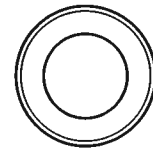

11



12

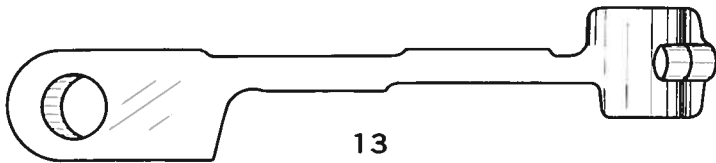

13



14



15

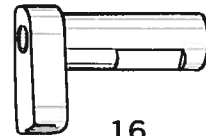

16



17

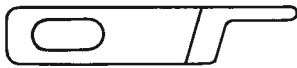

18



19

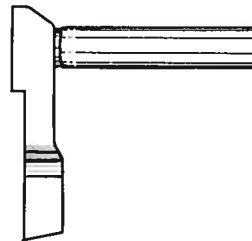

20



21



22



23



24



25

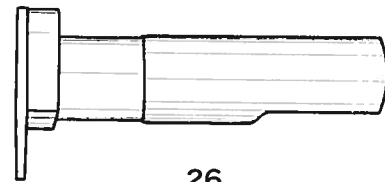

26



27



28



29



30

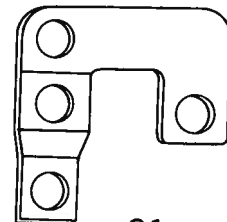

31



32



33



34



35

## UPPER & LOWER KNIFE MECHANISM

### 上・下メス機構

Ref. No. 参照番号	Parts No. 部品番号	Name	名称	Qt. 数量	Remarks 備考
1	○201380A	Upper knife connecting rod	上メスロッド	1	
2	○ 5002	＊ ＊ ＊ ＊ screw	＊ ＊ 蓋ネジ	2	
3	○202711A	＊ ＊ ＊ ＊ hinge pin	＊ ＊ ビン	1	
4	○ 1457	＊ ＊ ＊ ＊ ＊ ＊ screw	＊ ＊ ＊ 止ネジ	1	
5	201381	＊ ＊ lever shaft crank	上メスクランク	1	
6	○ 5087	＊ ＊ ＊ ＊ ＊ ＊ screw	＊ ＊ 抱締ネジ	1	
7	○ 5181	＊ ＊ ＊ ＊ ＊ ＊ ＊ ＊ nut	＊ ＊ ＊ ＊ ナット	1	
8	○201114	＊ ＊ ＊ shaft	上メス台軸	1	
9	○201115A	＊ ＊ ＊ ＊ bushing	＊ ＊ ブッシュ	2	
10	○ 1457-1	＊ ＊ ＊ ＊ ＊ ＊ screw	＊ ＊ ＊ 止ネジ	2	
11	○201117	＊ ＊ ＊ ＊ thrust washer	＊ ＊ スラストカラー	1	
12	○ 5084	＊ ＊ ＊ ＊ ＊ ＊ ＊ ＊ screw	＊ ＊ ＊ ＊ 止ネジ	2	
13	○202635	＊ ＊ ＊ lever	上メス台	1	
14	○201076	＊ ＊ ＊ ＊ cotter screw	＊ ＊ コッター	1	
15	○ 5181	＊ ＊ ＊ ＊ ＊ ＊ ＊ ＊ nut	＊ ＊ ＊ ＊ ナット	1	
16	○202636	＊ ＊ ＊ ＊ guide	＊ ＊ 案内	1	
17	○ 2022	＊ ＊ ＊ ＊ ＊ ＊ screw	＊ ＊ ＊ 止ネジ	1	
18	○201121A	＊ ＊ knife (tungsten tipped)	上メス	1	
19	○ 5088	＊ ＊ ＊ screw	＊ ＊ 止ネジ	1	
20	○202637A	＊ ＊ ＊ holder	＊ ＊ 抱キ	1	
21	○ 1175-2	＊ ＊ ＊ ＊ screw	＊ ＊ ＊ 抱締ネジ	1	
22	○202638A	＊ ＊ ＊ ＊ guide	＊ ＊ ＊ 案内	1	
23	○ 1222	＊ ＊ ＊ ＊ ＊ ＊ screw	＊ ＊ ＊ ＊ 止ネジ	1	
24	○201125	＊ ＊ ＊ ＊ ＊ ＊ pin	＊ ＊ ＊ ＊ ビン	1	
25	○202295	Lower knife	下メス	1	
26	○201128C	＊ ＊ ＊ ＊ holder	＊ ＊ 台	1	} DCR-901, 902 & 903 only 用
27	○ 4009-1	＊ ＊ ＊ ＊ ＊ ＊ screw	＊ ＊ ＊ 止ネジ	1	
28	○201129	＊ ＊ ＊ ＊ ＊ ＊ spring	＊ ＊ ＊ 押シバネ	1	
29	○201130A	＊ ＊ ＊ ＊ ＊ ＊ ＊ ＊ retainer	＊ ＊ ＊ ＊ ＊ 押エ	1	
30	○ 1175-3	＊ ＊ ＊ ＊ ＊ ＊ ＊ ＊ screw	＊ ＊ ＊ ＊ ＊ ＊ 止ネジ	2	
31	○201131A	＊ ＊ ＊ ＊ ＊ ＊ guide	＊ ＊ ＊ 案内板	1	
32	○ 1175-3	＊ ＊ ＊ ＊ ＊ ＊ ＊ ＊ screw	＊ ＊ ＊ ＊ ＊ 止ネジ	2	
33	○201132B	＊ ＊ ＊ ＊ ＊ ＊ clamp stud	＊ ＊ 止ピン	1	
34	○ 5260	＊ ＊ ＊ ＊ ＊ ＊ ＊ ＊ thumb nut	＊ ＊ ＊ ＊ ナット	1	
35	○201134	＊ ＊ ＊ ＊ ＊ ＊ ＊ ＊ ＊ ＊ washer	＊ ＊ ＊ ＊ ＊ 座金	1	

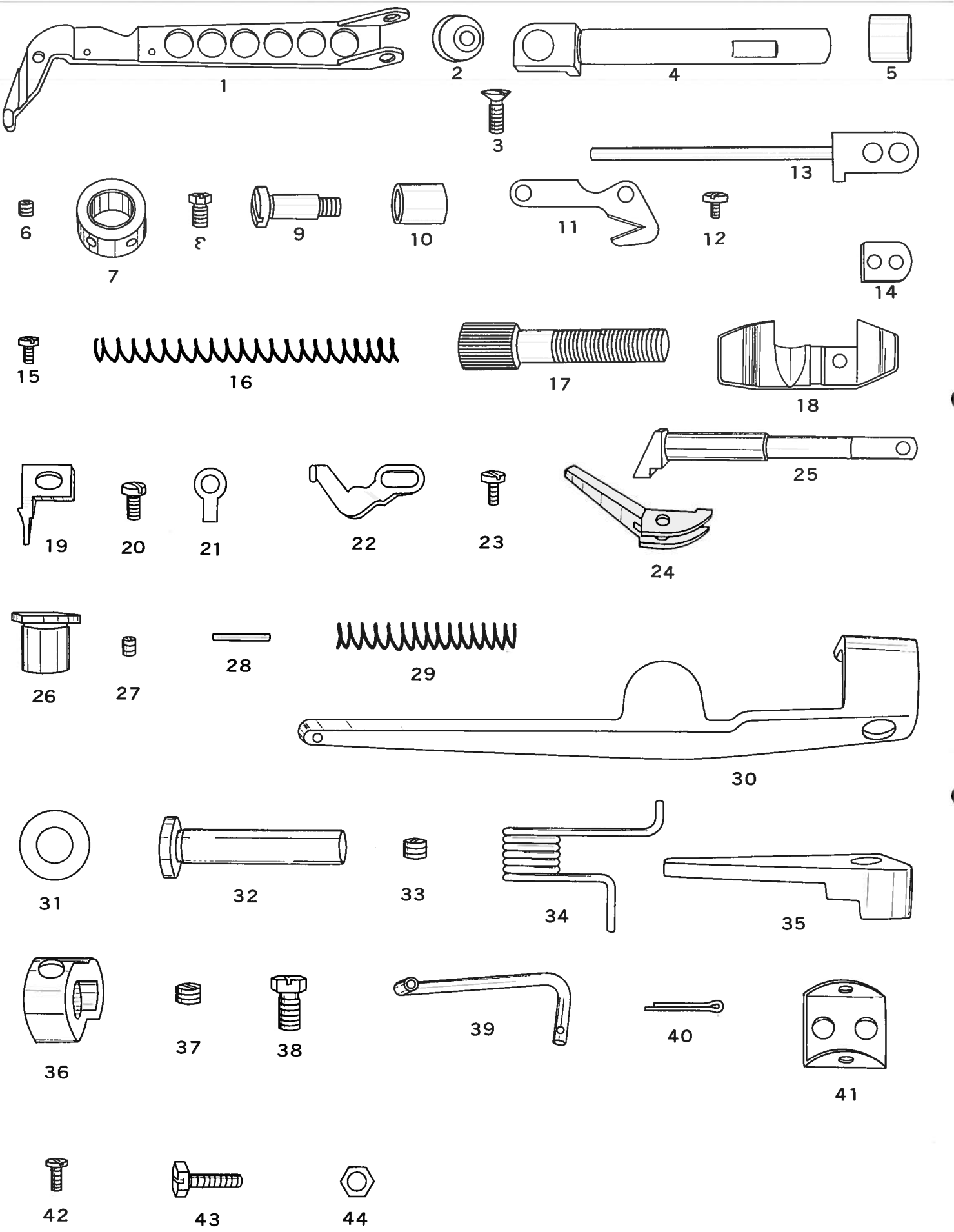



**PRESSER FOOT & LIFTING MECHANISM**

**押 工 機 構**

Ref. No. 参照番号	Parts No. 部品番号	Name	名 称	Qt. 数量	Remarks 備 考
1	202639	Presser arm	押エ台	1	
2	202683	＊ ＊ regulator (eccentric)	＊ 調節器	1	
3	1732	＊ ＊ ＊ screw	＊ ＊ 止ネジ	1	
4	202640	Foot lift lever shaft	＊ 軸	1	
5	○202589	＊ ＊ ＊ ＊ bushing	＊ ＊ ブッシュ	3	
6	1435	＊ ＊ ＊ ＊ ＊ screw	＊ ＊ ＊ 止ネジ	1	
7	202756	＊ ＊ ＊ ＊ collar	＊ ＊ カラー	1	
8	5084	＊ ＊ ＊ ＊ ＊ screw	＊ ＊ ＊ 止ネジ	2	
9	○ 5164	Presser arm hinge screw	＊ 蝶番ネジ	1	
10	○201141	＊ ＊ ＊ ＊ bushing	＊ ＊ ブッシュ	1	
11	○201308	Chain cutter knife	チェーンカッター	1	
12	1333	＊ ＊ ＊ screw	＊ 止ネジ	2	
13	202641	Presser spring plunger	押エ棒	1	
14	202642	＊ ＊ ＊ ＊ guide	＊ 片	1	
15	5033	＊ ＊ ＊ ＊ ＊ screw	＊ 止ネジ	2	
16	201388	＊ spring	押エバネ	1	
17	202643	＊ ＊ regulating thumb screw	＊ 調節ネジ	1	
18	○201152D	Presser foot	押エ	1	} DCR-901 & 981 only用
19	○201155C	＊ ＊ chaining-off finger	＊ 爪	1	
20	○ 5089	＊ ＊ ＊ ＊ ＊ screw	＊ ＊ 止ネジ	1	
21	○201156	＊ ＊ hinge spring	＊ 取付板	1	
22	202682	＊ ＊ regulator	＊ 固定金	1	
23	1196	＊ ＊ ＊ ＊ screw	＊ ＊ 止ネジ	1	
24	202644	Hand lift lever	手揚	1	
25	202645	＊ ＊ ＊ ＊ spring plunger	＊ 軸	1	
26	202646	＊ ＊ ＊ ＊ ＊ ＊ bushing	＊ ＊ ブッシュ	1	
27	1157	＊ ＊ ＊ ＊ ＊ ＊ ＊ screw	＊ ＊ ＊ 止ネジ	1	
28	202647A	＊ ＊ ＊ ＊ hinge pin	＊ ピン	1	
29	201395	＊ ＊ ＊ ＊ spring	＊ バネ	1	
30	○201160B	Foot lift lever	足揚 (大)	1	
31	○202868	＊ ＊ ＊ ＊ hinge pin washer	＊ ＊ 座金	1	
32	○201161	＊ ＊ ＊ ＊ ＊ pin	＊ ＊ ピン	1	
33	○ 2022	＊ ＊ ＊ ＊ ＊ ＊ screw	＊ ＊ ＊ 止ネジ	1	
34	○201162A	＊ ＊ ＊ ＊ ＊ spring	＊ バネ	1	
35	○201163	＊ ＊ ＊ ＊ ＊ intermediate lever	＊ (小)	1	
36	○201161A	＊ ＊ ＊ ＊ ＊ ＊ collar	＊ カラー	1	
37	○ 2022	＊ ＊ ＊ ＊ ＊ ＊ ＊ screw	＊ ＊ ＊ 止ネジ (頭ナシ)	1	
38	○ 2022-4	＊ ＊ ＊ ＊ ＊ ＊ ＊ ＊ screw	＊ ＊ ＊ (頭ツキ)	1	
39	○201165	＊ ＊ ＊ ＊ ＊ lever connecting link	＊ 連結ピン	1	
40	○201166	＊ ＊ ＊ ＊ ＊ ＊ cotter pin	＊ 割ピン	2	
41	○201167	＊ ＊ ＊ ＊ ＊ bracket	＊ 調節台 (コ型)	1	
42	○ 5142	＊ ＊ ＊ ＊ ＊ ＊ screw	＊ ＊ ＊ 止ネジ	2	
43	○ 5097	＊ ＊ ＊ ＊ ＊ ＊ regulating screw	＊ 調節ネジ	2	
44	○ 3044	＊ ＊ ＊ ＊ ＊ ＊ ＊ nut	＊ ＊ ナット	2	

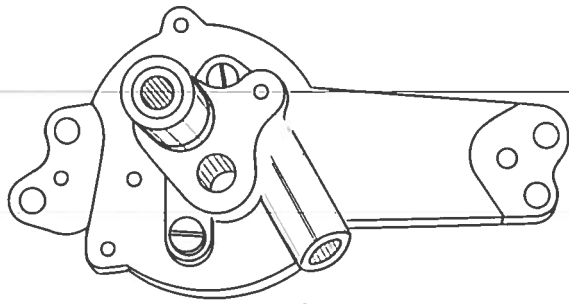

1



2

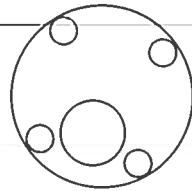

3



4



5



6



7



8



9



10



11

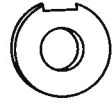

12



13



14



15

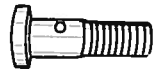

16



17



18

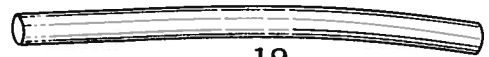

19



20

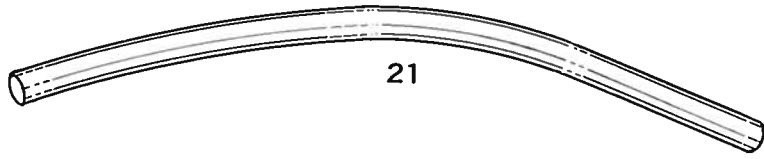

21



22

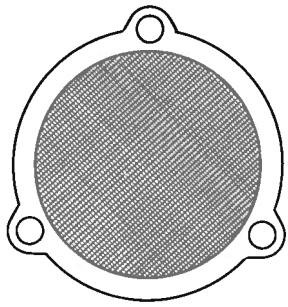

23

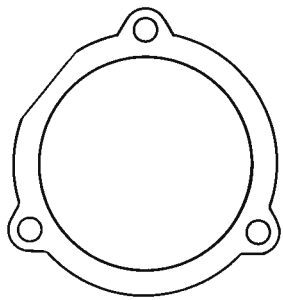

24

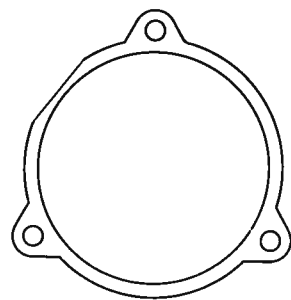

25



26

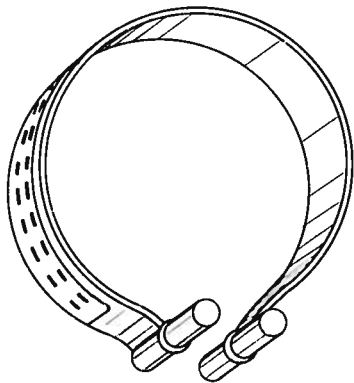

27



28



29



30



31



32



33

PUMP & LUBRICATING MECHANISM(1)

ポンプ・給油機構(1)

Ref. No. 参照番号	Parts No. 部品番号	Name 名称	名称	Qty. 数量	Remarks 備考
1	○201288A	Casing, complete with	ケーシング(組)	1	{ 201548×2 201290A 2213-1×2 201291 201292 との組
	○201548	＊ hinge pin	＊ ノックピン	2	
	○201289A	Pump base	ポンプベース	1	
	○201290A	Gear casing	ギヤケース	1	
	○ 2213-1	＊ ＊ screw	＊ 止ネジ	2	
	○201291	Cotter pin	コールピン(A)	1	
	○201292	＊ ＊	＊ (B)	1	
2	○ 2213-1	Casing screw	ケーシング(組)止ネジ	4	
3	○201293A	＊ cover plate	側板	1	
4	○ 5117	＊ ＊ ＊ screw	＊ 止ネジ	4	
5	○201294	Pump gear for 201296	ポンプギヤ(A)	1	
6	○201295	＊ gear for 201297	＊ (B)	1	
7	○201296	＊ ＊ shaft (long), with 201109	ギヤシャフト(A)	1	201009との組
	○201009	＊ ＊ ＊ key	＊ キー	1	
8	○201297	＊ ＊ shaft (short)	＊ (B)	1	
9	○ 1458	＊ ＊ ＊ screw	＊ ＊ 止ネジ	2	
10	○201298	Worm	ウオーム	1	
11	○ 5060	＊ screw	＊ 止ネジ	2	
12	○202722A	＊ gear thrust washer	ウオームギヤスラストワッシャ	1	
13	○201299	＊ wheel	ウオームホイール	1	
14	○ 5060	＊ ＊ screw	＊ 止ネジ	2	
15	○201300	Oil distributing tube joint	給油パイプ継手雌(A)	1	
16	○201301	＊ ＊ ＊ ＊ screw	＊ 継手雄(A)	1	
17	○201302	＊ ＊ ＊ ＊ ＊ washer	＊ 継手パッキン	2	
18	○201303	＊ ＊ ＊ clamp	＊ 抱締パネ(A)	4	
19	○201319	＊ ＊ tube	ビニールパイプ(A)	1	
20	○201304	＊ ＊ ＊ spring	＊ ＊ 抱パネ	1	
21	○201320	＊ ＊ tube	＊ (B)	1	
22	202727	＊ ＊ ＊ spring	＊ ＊ 抱パネ	1	
23	○201338	＊ screen filter, complete with 201339 & 201340	フィルター(組)	1	{ 201339, 201340 との組
	○201339	＊ ＊ filter (external)	＊ 外層金網		
	○201340	＊ ＊ ＊ (internal)	＊ 内層金網	1	
24	○201311	＊ ＊ ＊ gasket	＊ 内枠パッキン	1	
25	○201311	＊ ＊ ＊ frame	＊ 取付板	1	
26	○ 1175-2	＊ ＊ ＊ ＊ screw	＊ 止ネジ	3	
27	○201342B	＊ radiator, complete with 201484, 201343Bx3 & 201344Bx2	冷却器	1	{ 201484, 201343Bx3, — 201344Bx2 との組
	○201484	＊ radiator tube band	冷却管固定帯板	1	
	○201343B	＊ ＊ tube	冷却管	3	
	○201344B	＊ ＊ ＊ joint	＊ 継手	2	
28	○201345A	＊ ＊ clamp	冷却器止金	1	
29	○ 3001	＊ ＊ ＊ screw	＊ ＊ 止ネジ	1	
30	○201315	＊ ＊ retaining plate	＊ 継手止板	1	
31	○201316	＊ ＊ ＊ ＊ gasket	＊ ＊ パッキン	1	
32	○ 5152	＊ ＊ ＊ ＊ screw	＊ ＊ 止ネジ	2	
33	○200149	＊ ＊ ＊ ＊ ＊ washer	＊ ＊ ＊ パッキン	2	

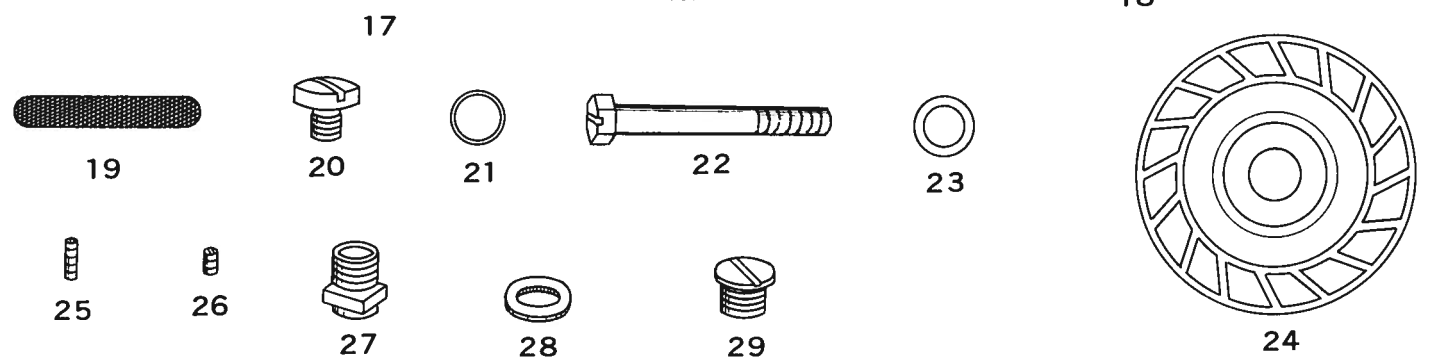
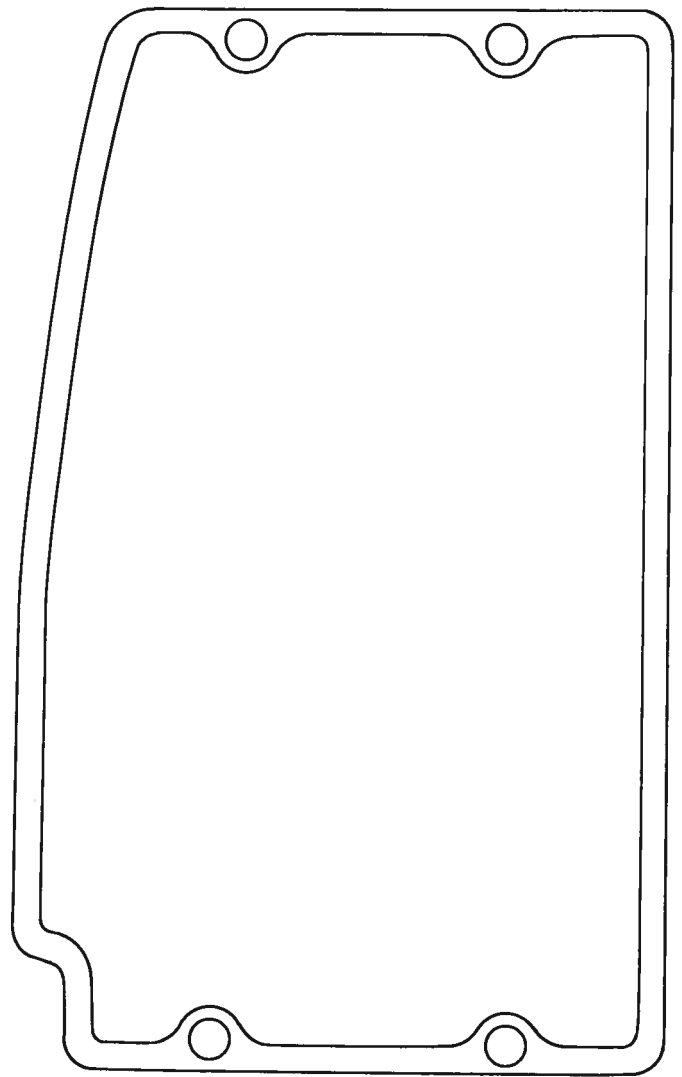
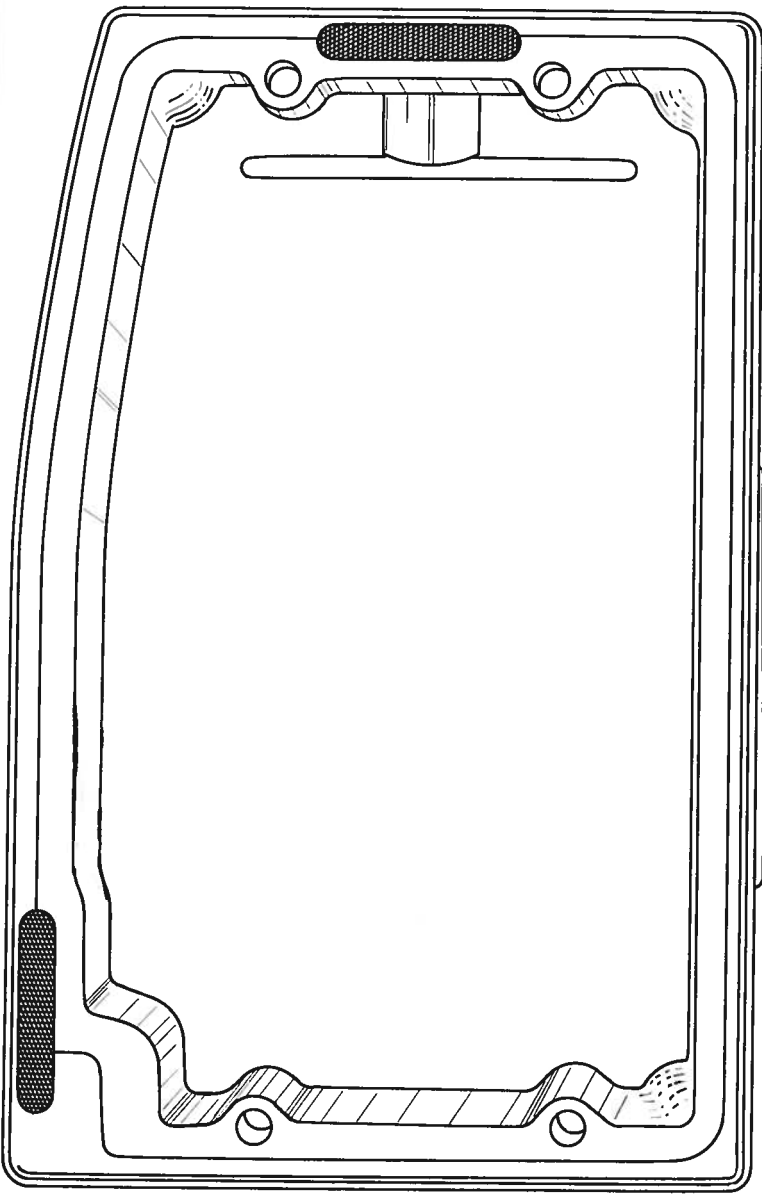
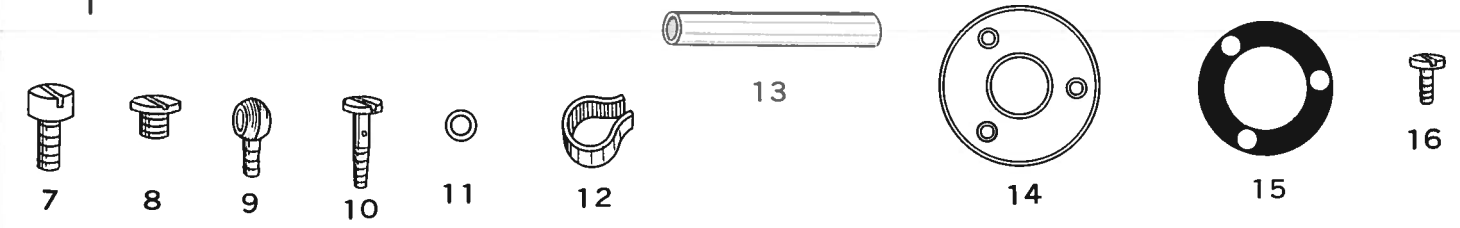
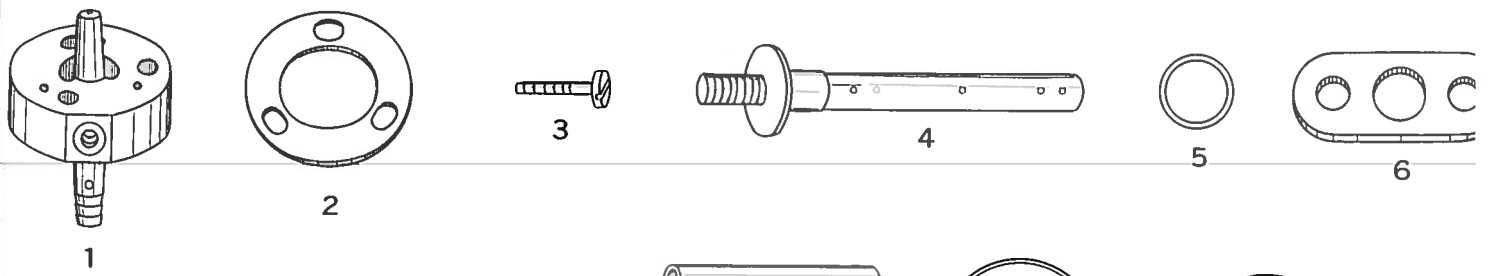

PUMP & LUBRICATING MECHANISM(2)

ポンプ・給油機構(2)

Ref. No. 参照番号	Parts No. 部品番号	Name 名称	名 称	Qt. 数量	Remarks 備 考
1	201422A	Oil distributor	油配分器	1	
2	201423	〃 〃 gasket	〃 パッキン	1	
3	2838	〃 〃 screw	〃 止ネジ	3	
4	201424	〃 splash pipe	噴油管	1	
5	201425	〃 〃 〃 washer	〃 パッキン	1	
6	201429	〃 〃 〃 retaining plate	〃 止板	1	
7	5064	〃 〃 〃 〃 screw	〃 〃 止ネジ	2	
8	5261	〃 〃 〃 cap screw	〃 蓋ネジ	1	
9	200136	〃 distributing tube joint	給油パイプ継手雌 (B)	1	
10	200137	〃 〃 〃 〃 screw	〃 継手雄 (B)	1	
11	200138	〃 〃 〃 〃 〃 washer	〃 〃 〃 パッキン	2	
12	200155	〃 〃 〃 〃 clamp	〃 抱締バネ (B)	2	
13	201426	〃 〃 〃 tube	ビニールパイプ (C)	1	
14	○201328	〃 splash sight window	オイルマド	1	
15	○201329	〃 〃 〃 〃 gasket	〃 パッキン	1	
16	○ 5142	〃 〃 〃 〃 〃 screw	〃 止ネジ	3	
17	○201334B	〃 reservoir (machine base)	オイルパン	1	
18	○201335	〃 〃 gasket	〃 パッキン	1	
19	○201487	〃 strainer for 201334B	〃 油濾弁板	2	
20	○ 5138A	〃 drain plug screw	〃 排油穴蓋ネジ	1	
21	○202287	〃 〃 〃 〃 〃 washer	〃 〃 パッキン "O" リング	1	
22	○ 5150	〃 reservoir bolt	〃 取付ボルト	4	
23	○201302	〃 〃 〃 washer	〃 〃 パッキン	4	
24	○201325B	〃 radiator fan	ファン	1	
25	○ 5149	〃 〃 〃 position screw	〃 止ネジ (先右)	1	
26	○ 1458	〃 〃 〃 screw	〃 止ネジ (先ナシ)	1	
27	202658A	〃 filler pipe	注油口金	1	
28	○201006	〃 〃 〃 washer	〃 パッキン	1	
29	○ 5198	〃 〃 plug screw	〃 蓋ネジ	1	

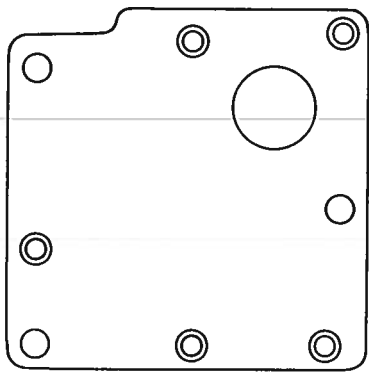

1

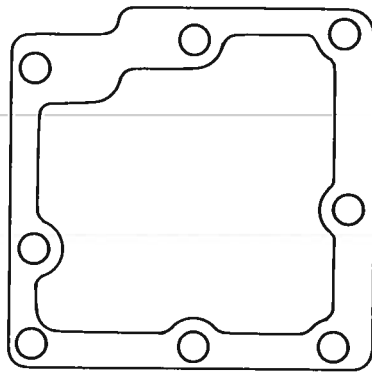

2



3

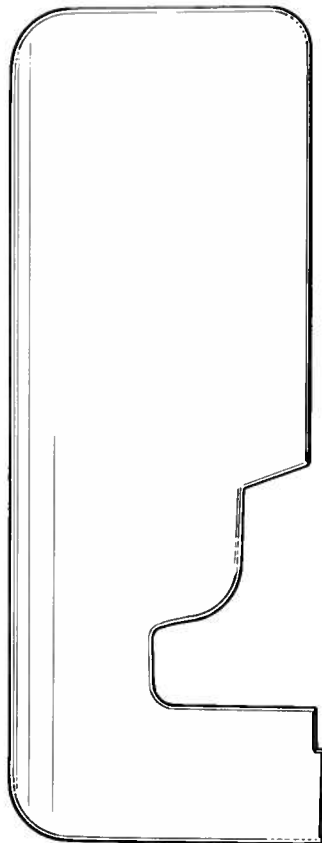

4

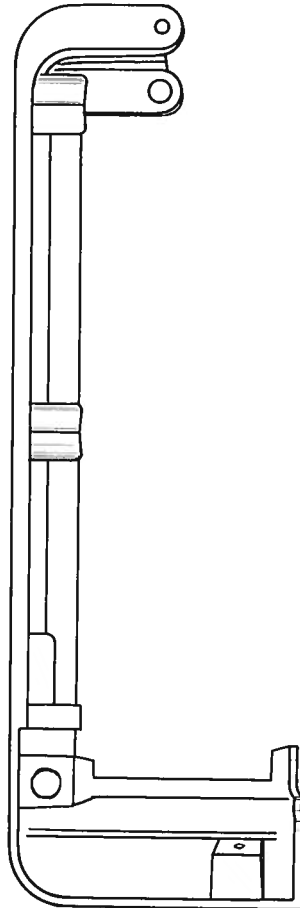

5



6



7



8



9

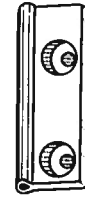

10



11



12



13



14



15



16



17

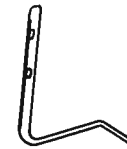

18



19



20



21



22



23



24

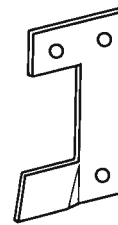

25



26

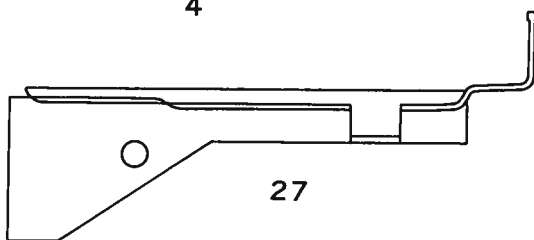

27



28

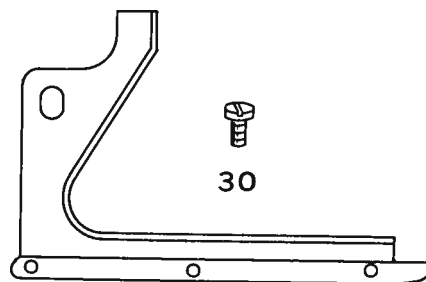

29



30

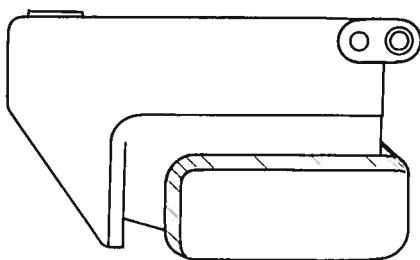

31



32



33

CLOTH PLATE & MISCELLANEOUS COVERS

カバ ー ・ 外 装 関 係 (1)

Ref. No. 参照番号	Parts No. 部品番号	Name 名称	名 称	Qty. 数量	Remarks 備 考
1	202648A	Machine arm (right) cover plate	アーム上板	1	
2	202649	〃 〃 〃 〃 〃 gasket	〃 パッキン	1	
3	1732	〃 〃 〃 〃 〃 screw	〃 止ネジ	5	
4	〇201180 〇201181B	Cloth plate, complete with plate	大カバー (組) 上	1 1	DCR-901, 902, 903, 905, 909 & 915only用
		{ 201181B, 201182Ax1 201183A, 1216x4, ( 1202x4, 201185x1 & 201184x1	{ 201181B, 201182Ax1 201183A, 1216x4 1202x4, 201185x4 201184x1との組		
	〇201182A	〃 〃 nut	〃 〃 ヘッ	4	
5	〇201183A	〃 〃 extension	〃 下	1	DCR-901, 902, 903, 905, 909 & 915only用
6	〇201184	〃 〃 〃 bracket	〃 上・下取付台	4	
7	〇 1216	〃 〃 〃 〃 screw (upper)	〃 〃 〃 上止ネジ	4	
8	〇 1202	〃 〃 〃 〃 screw (lower)	〃 〃 〃 下止ネジ	4	
9	〇201185	〃 〃 〃 〃 〃 〃 washer	〃 〃 〃 〃 〃 座金	4	
10	〇200159	〃 〃 hinge	〃 ヒンジ	1	
11	〇 2213-1	〃 〃 〃 screw	〃 〃 止ネジ	2	
12	〇200183	〃 〃 〃 thrust washer	〃 〃 スラストカラー	1	
13	〇201221	〃 〃 〃 pin	〃 〃 ピン	1	
14	〇 5099	〃 〃 〃 〃 nut	〃 〃 〃 締付ナット	1	
15	〇200821	〃 〃 〃 〃 〃 washer	〃 〃 〃 〃 〃 座金	1	
16	〇202865	〃 〃 〃 〃 stop	〃 〃 〃 廻り止め	1	
17	〇 5136	〃 〃 〃 〃 〃 screw	〃 〃 〃 〃 〃 止ネジ	1	
18	〇201186	〃 〃 lock spring	〃 止バネ	1	
19	〇 1216	〃 〃 〃 〃 screw	〃 〃 止ネジ	2	
20	〇200162	〃 〃 〃 〃 〃 washer	〃 〃 〃 〃 〃 座金	1	
21	〇200163	〃 〃 〃 〃 catch	〃 〃 掛金	1	
22	〇 1435	〃 〃 〃 〃 〃 screw	〃 〃 〃 止ネジ	1	
23	〇 1435	〃 〃 stop screw	〃 ストップネジ	1	
24	〇 3044	〃 〃 〃 〃 nut	〃 〃 ナット	1	
25	202650	Machine arm (left) face plate	面板	1	
26	1196	〃 〃 〃 〃 〃 screw	〃 止ネジ	1	
27	202651	Cloth plate fabric guard	表除ケ	1	
28	〇 1216	〃 〃 〃 〃 〃 screw	〃 止ネジ	2	
29	〇201188	Machine bed oil shield	ベッド油除ケ	1	
30	〇 1216	〃 〃 〃 〃 〃 screw	〃 止ネジ	4	
31	〇201189A	Feed mechanism cover	送り台カバー	1	
32	〇 5215A	〃 〃 〃 〃 screw	〃 取付ネジ	1	
33	〇201191	〃 〃 〃 〃 〃 washer	〃 〃 〃 〃 〃 座金	2	

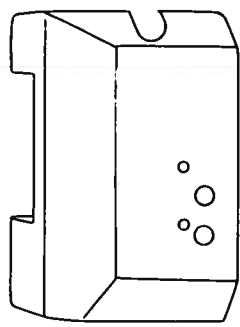

1



2

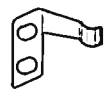

3



4



7



5



6

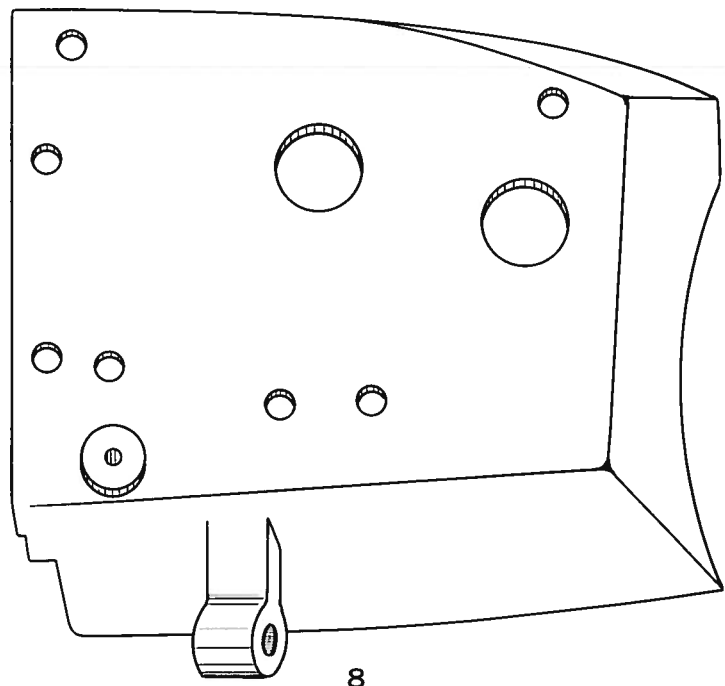

8

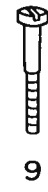

9



10



11



15

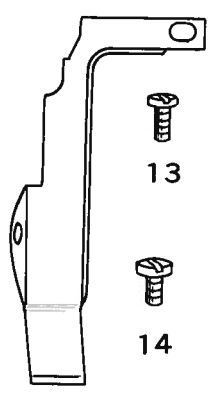

12



13



14



16



17

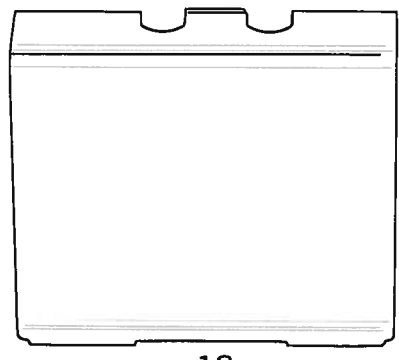

18

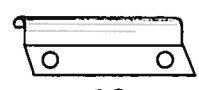

19



20



21



22



23

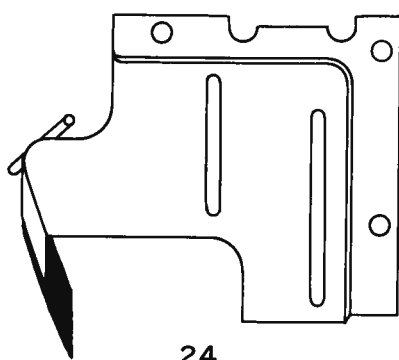

24



25

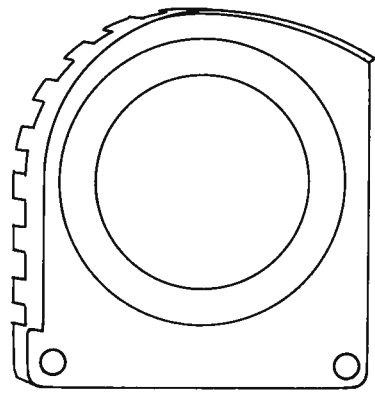

26



27

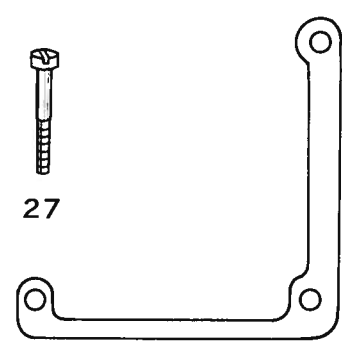

28



MAIN FRAME & MISCELLANEOUS COVERS

カバ ー ・ 外 装 関 係 (2)

Ref. No. 参照番号	Parts No. 部品番号	Name 名称	Qty. 数量	Remarks 備 考
1	202652	Needle bar cover	1	針棒カバー
2	202653	＊ ＊ ＊ hinge pin	2	＊ ヒンヂピン
3	202689	＊ ＊ ＊ lock spring	1	＊ 止バネ (A)
4	1234	＊ ＊ ＊ ＊ ＊ screw	2	＊ ＊ ＊ 止ネジ
5	201401	＊ ＊ ＊ ＊ ＊ catch	1	＊ ＊ (B)
6	4009-1	＊ ＊ ＊ ＊ ＊ ＊ screw	1	＊ ＊ ＊ 止ネジ
7	201428	＊ ＊ ＊ name plate	1	＊ 銘板
8	202651A	Machine top cover	1	上カバー
9	○ 5095	＊ ＊ ＊ screw	3	＊ 止ネジ
10	202655	Oil shield for 202608	1	針棒リンク油除ケ
11	1206	＊ ＊ ＊ screw	2	＊ 止ネジ
12	202680	Chip guard (left)	1	前カバー (左)
13	○ 1216	＊ ＊ ＊ screw (upper)	1	＊ ＊ 止ネジ (上)
14	○ 2905	＊ ＊ ＊ screw (lower)	1	＊ ＊ ＊ (下)
15	○202701	＊ ＊ ＊ extension	1	切屑除ケ
16	○202660	＊ ＊ ＊ guard (right)	1	前カバー (中)
17	○ 2921	＊ ＊ ＊ screw	2	＊ ＊ 止ネジ
18	○201200	Front cover	1	＊ (右)
19	○201201	＊ ＊ ＊ hinge	1	＊ ＊ ヒンヂ
20	○ 1216	＊ ＊ ＊ screw	2	＊ ＊ ＊ 止ネジ
21	○201202	＊ ＊ ＊ pin	1	＊ ＊ ＊ ピン
22	○201203	＊ ＊ ＊ lock spring	1	＊ ＊ 止バネ
23	○ 1216	＊ ＊ ＊ ＊ ＊ screw	1	＊ ＊ ＊ 止ネジ
24	202657B	Looper thread plate, complete with	1	大ルーバー台カバー
	○202762	＊ ＊ ＊ plate oil shield	1	＊ 油除ケ
	202632A	＊ ＊ ＊ tube	1	大ルーバー糸道パイプ
	○201235	＊ ＊ ＊ plate extension rivet	1	大ルーバー台カバー油除ケリベット
	○201236	＊ ＊ ＊ ＊ ＊ ＊ washer	1	＊ 座金
25	○ 1216	＊ ＊ ＊ screw	3	大ルーバー台カバー止ネジ
26	○201318A	Oil radiator cover	1	冷却器カバー
27	○ 5091	＊ ＊ ＊ screw	3	＊ 止ネジ
28	○202748	＊ ＊ ＊ gasket	1	＊ ＊ パッキン



1

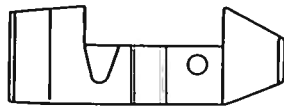

2

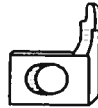

3



4

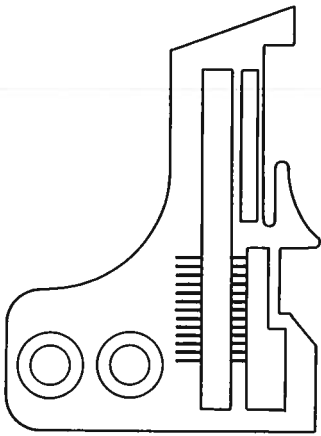

5-1

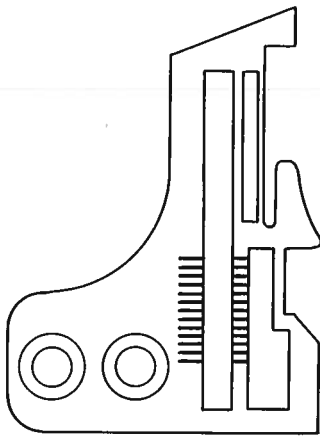

5-2

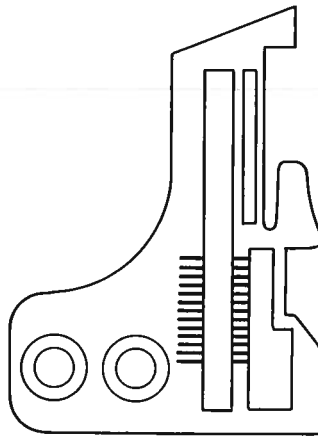

5-3

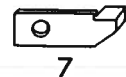

7



8

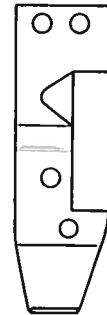

6



10



9

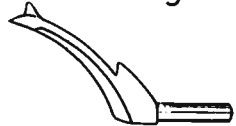

11

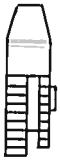

12



13

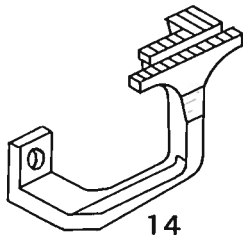

14



15

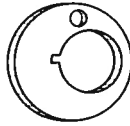

16



17



18

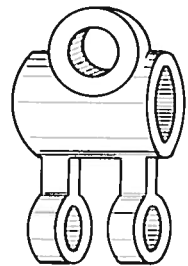

19

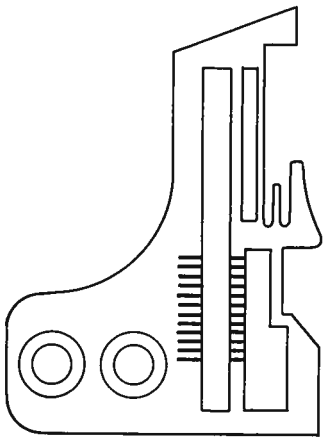

20-1

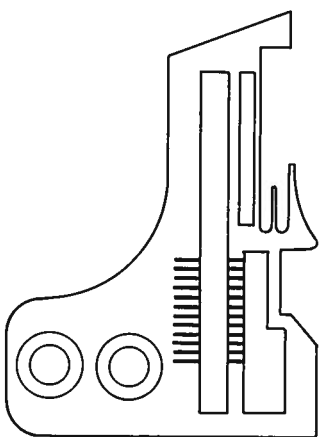

20-2

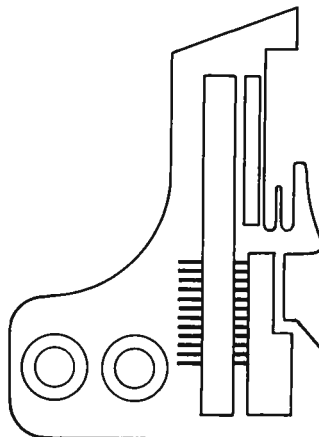

20-3



21



22

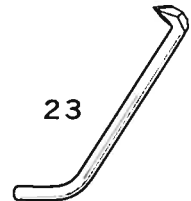

23



24

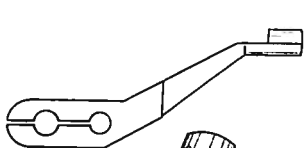

25

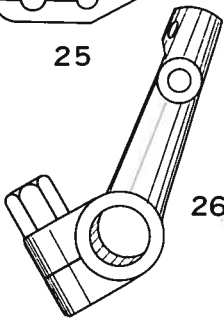

26

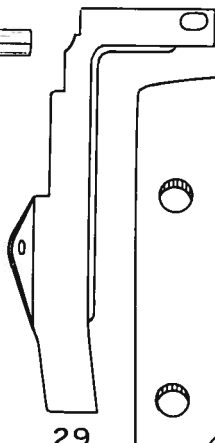

29

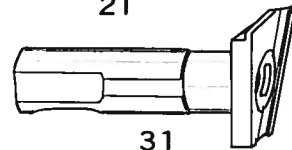

31

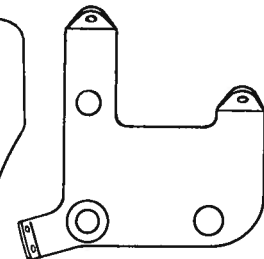

32



33



27



28

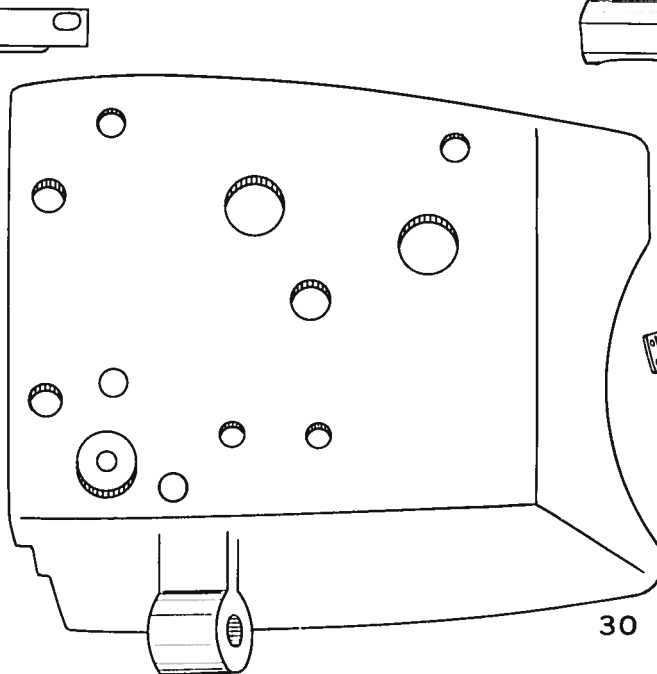

30

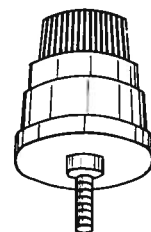

34



35

**PARTS FOR MODEL DCR-902 ONLY**

**DCR-902 型 専用 部品**

Ref. No. 参照番号	Parts No. 部品番号	Name 名称	名称	Qty. 数量	Remarks 備考
1	202665	Model plate	型式板	1	
2	○201473A	Presser foot	押エ	1	
3	○201221A	＊ ＊ chaining-off finger	＊ 爪	1	Also for DCR-903 共用

**PARTS FOR MODEL DCR-903 (2-THREAD MACHINE) ONLY**

**DCR-903 型 (2本糸) 専用 部品**

4	202666	Model plate	型式板	1	
5-1	○202684	Needle plate (3mm seam width)	針板 (縫巾3.0mm)	1	
5-2	○202685	＊ plate (4mm seam width)	＊ (＊ 4.0mm)	1	
5-3	○202669	＊ plate (5mm seam width)	＊ (＊ 5.0mm)	1	
6	○201230B	Presser foot	押エ	1	Also for DCR-905, 909(2mm), 985 & 989(2mm) 共用
3	○201224A	＊ ＊ chaining-off finger	＊ 爪	1	Also for DCR-902 共用
7	○201265B	＊ ＊ fabric guard	補助押エ	1	Also for DCR-905, 909, 915, 985 & 989 共用
8	1231	＊ ＊ ＊ ＊ screw	＊ 止ネジ	1	
9	○201270A	＊ ＊ chain shield	押エ補助板	1	Also for DCR-905, 909, 915, 985 & 989 共用
10	5030	＊ ＊ ＊ ＊ screw	＊ 止ネジ	1	
11	202840	Right looper (Spreader)	大ルーバー #5	1	
12	○201153	Main feed dog	主送り歯	1	
13	○202671	Auxiliary feed dog	補助送り歯	1	
14	201379B	Differential feed dog	差動送り歯	1	
15	○201154	Main feed connecting link bushing	主送り連結桿ブッシュ	1	Also for DCR-915 共用
16	○201103-5.5	Feed eccentric #5.5	送りエキセン #5.5	2	

**PARTS FOR MODEL DCR-905 & 915 (2-NEEDLE MACHINE) ONLY**

**DCR-905・915 型 (2本針) 専用 部品**

17	202667	Model plate	型式板	1	DCR-905 only用
18	202753	＊ plate	＊	1	DCR-915 only用
19	201441	Needle bar crank (right)	針棒後クランク	1	DCR-909, 915 & 989 only用
20-1	○202674	＊ plate (1.5mm gauge x 4mm seam width)	針板(針巾1.5mm縫巾4.0mm)	1	Also for DCR-985 共用
20-2	○202702	＊ plate (2.0mm gauge x 4mm seam width)	＊ (＊ 2.0＊ ＊ 4.0＊)	1	Also for DCR-985 共用
20-3	○202675	＊ plate (2.0mm gauge x 5mm seam width)	＊ (＊ 2.0＊ ＊ 5.0＊)	1	Also for DCR-909, 985 & 989 共用
21	202672	＊ bar (1.5mm gauge)	針棒 (1.5mm)	1	Also for DCR-985 共用
	202673	＊ bar (2.0mm gauge)	＊ (2.0mm)	1	Also for DCR-909, 985 & 989 共用
22	5292	＊ clamp screw	針止ネジ	2	
23	202719	＊ guard (lower)	針受 (B)	1	Also for DCR-909, 985 & 989 共用
24	1186	＊ ＊ ＊ screw	＊ ＊ 止ネジ	1	
25	201451A	＊ guard (upper)	＊ (A)	1	Also for DCR-909, 985 & 989 共用
26	202728	Left looper bar	小ルーバー台	1	Also for DCR-909, 985 & 989 共用
6	○201230B	Presser foot	押エ	1	Also for DCR-903, 909, 985 & 989 共用
27	○201396A	＊ ＊ chaining-off finger	爪	1	Also for DCR-985 共用
7	○201265B	＊ ＊ fabric guard	補助押エ	1	Also for DCR-903, 909, 985 & 989 共用
8	○ 1231	＊ ＊ ＊ ＊ screw	＊ 止ネジ	1	
9	○201270A	＊ ＊ chain shield	押エ補助板	1	Also for DCR-903, 909, 985 & 989 共用
10	○ 5030	＊ ＊ ＊ ＊ screw	＊ 止ネジ	1	
14	201379B	Differential feed dog	差動送り歯	1	Also for DCR-903, 909, 985 & 989 共用
15	○201154	Main feed connecting link bushing	主送り連結桿ブッシュ	1	Also for DCR-903 共用
16	○201103-10	Feed eccentric #10	送りエキセン #10	1	} DCR-915 only用
	○201103-6	＊ eccentric #6	＊ #6	1	
28	202719	Right looper	大ルーバー #6	1	Also for DCR-985 共用
29	202755	Chip guard (left)	前カバー (左)	1	Also for DCR-909 共用
30	202686	Machine top cover	上カバー	1	Also for DCR-909, 985 & 989 共用
31	202739	Lower knife holder	下メス台	1	Also for DCR-909, 981, 985 & 989 共用
32	○201243A	Needle thread tension guide	針糸調子台	1	Also for DCR-909, 985 & 989 共用
33	○ 1732	＊ ＊ ＊ ＊ screw	＊ 止ネジ	1	
34	○202478	＊ ＊ ＊ complete	針糸調子 (組)	1	Also for DCR-909, 985 & 989 共用
35	○ 3044	＊ ＊ ＊ screw stud nut	針糸調子棒止ナット	1	

**PEBASUS**  
DCR-909



1

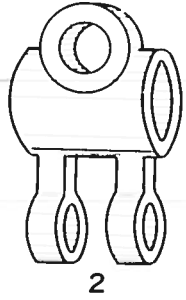

2

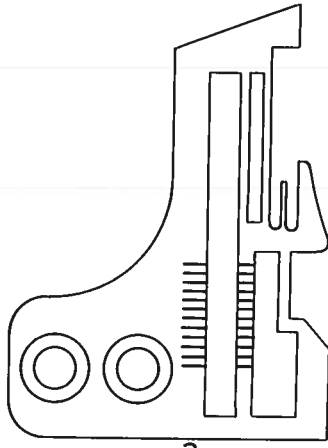

3



4



5

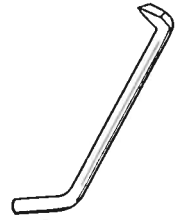

6



7

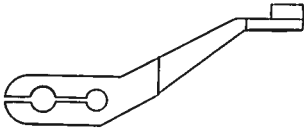

8

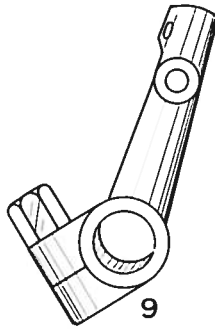

9

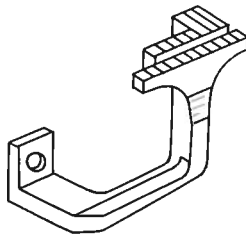

10

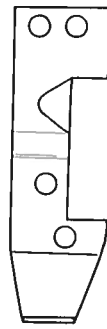

11

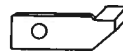

12



13



14



15

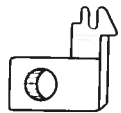

16

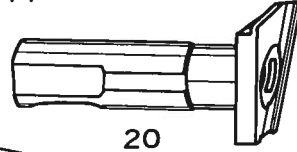

20

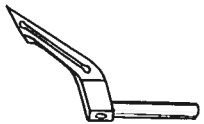

17

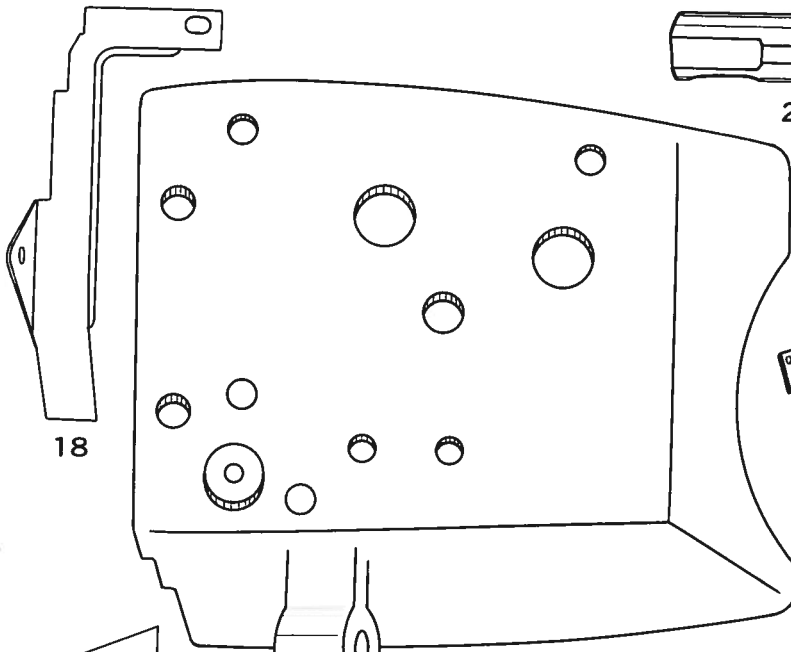

18

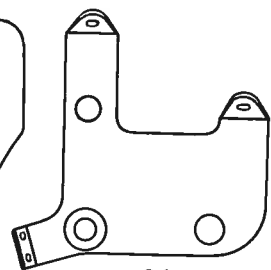

21



22



25

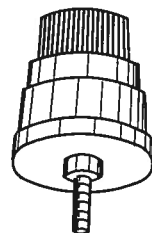

23



24

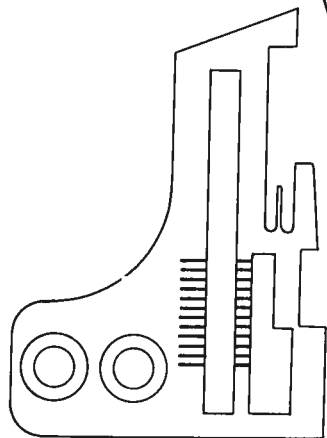

26

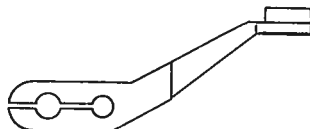

27



28



29



30

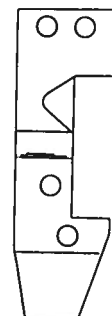

31

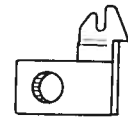

32

PARTS FOR MODEL DCR-909 (2-NEEDLE MACHINE) ONLY

DCR-909 型 (2本針) 専用部品

Ref. No. 参照番号	Parts No. 部品番号	Name 名称	名 称	Qty. 数量	Remarks 備 考
1	*202668	Model plate	型式板	1	
2	*201441	Needle bar crank (right)	針棒後クランク	1	Also for DCR-915 & 989 共用
3	○ 202675	◇ plate (2.0mm gauge x 5mm seam width)	針板 (針印2.0mm縫巾5.0mm)	1	Also for DCR-905, 915, 985 & 989 共用
4	202673	◇ bar	針棒	1	Also for DCR-905, 915, 985 & 989 共用
5	* 5292	◇ clamp screw	針止ネジ	2	
6	*202749	◇ guard (lower)	針受 (B)	1	Also for DCR-905, 915, 985 & 989 共用
7	* 1186	◇ ◇ ◇ screw	◇ ◇ 止ネジ	1	
8	201454A	◇ ◇ (upper)	◇ (A)	1	Also for DCR-905, 915, 985 & 989 共用
9	*202728	Left looper bar	小ルーバー台	1	Also for DCR-905, 915, 985 & 989 共用
10	201379 B	Differential feed dog	差動送り歯	1	Also for DCR-903, 905, 915, 985 & 989 共用
11	○ 201230B	Presser foot	押エ	1	Also for DCR-903, 905, 915, 985 & 989 共用
12	○ *201265B	◇ ◇ fabric guard	補助押エ	1	Also for DCR-903, 905, 915, 985 & 989 共用
13	○ * 1231	◇ ◇ ◇ ◇ screw	◇ 止ネジ	1	
14	○ *201270A	◇ ◇ chain shield	押エ補助板	1	Also for DCR-903, 905, 915, 985 & 989 共用
15	○ * 5030	◇ ◇ ◇ ◇ screw	◇ ◇ 止ネジ	1	
16	○ 201310A	◇ ◇ chaining-off finger	◇ 爪	1	
17	*202828	Right looper	大ルーバー #4	1	Also for DCR-901, 902, 981 & 989 共用
18	*202755	Chip guard (left)	前カバー (左)	1	Also for DCR-905 & 915 共用
19	*202686	Machine top cover	上カバー	1	Also for DCR-905, 915, 985 & 989 共用
20	*202739	Lower knife holder	下メス台	1	Also for DCR-905, 915, 981, 985 & 989 共用
21	○ *201243A	Needle thread tension guide	針糸調子台	1	Also for DCR-905, 915, 985 & 989 共用
22	○ * 1732	◇ ◇ ◇ ◇ screw	◇ 止ネジ	1	
23	○ *202478	◇ ◇ ◇ complete	針糸調子 (組)	1	Also for DCR-905, 915, 985 & 989 共用
24	○ * 3014	◇ ◇ ◇ screw stud nut	◇ 棒止ナット	1	
25	202677	Needle bar (3mm needle gauge)	針棒	1	針巾 3.0mm用
26	202678	◇ plate (◇ ◇ ◇)	針板	1	◇ ◇
27	201458A	◇ guard (upper) (◇ ◇ ◇)	針受 (A)	1	◇ ◇
28	○ 201269	Main feed dog (◇ ◇ ◇)	主送り歯	1	◇ ◇
29	202679	Auxiliary feed dog (◇ ◇ ◇)	補助送り歯	1	◇ ◇
30	1333	◇ ◇ ◇ screw (◇ ◇ ◇)	◇ 止ネジ	1	◇ ◇
31	○ 201261A	Presser foot (◇ ◇ ◇)	押エ	1	◇ ◇
32	○ 201461	◇ ◇ chaining-off finger (◇ ◇ ◇)	◇ 爪	1	◇ ◇

Note: Parts Number marked with an asterisk (\*) are for both 2mm and 3mm needle gauge machines.

注: 部品No.の前に\*印の付してある部品は2mm, 3mm針巾のミシンに共通である。

PEGASUS  
DCR-981



PEGASUS H.R. 装置  
特許 実用新案 願 済  
MIMA SEWING MACHINE CO., LTD

1

2

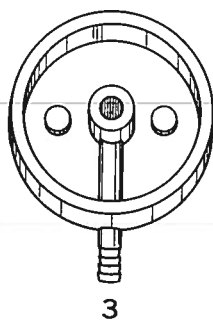

3

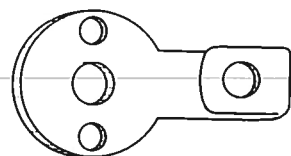

4

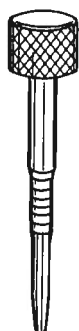

5

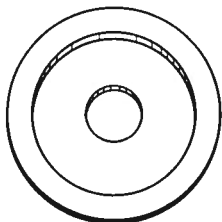

6



7



8



9



13



10



11



12

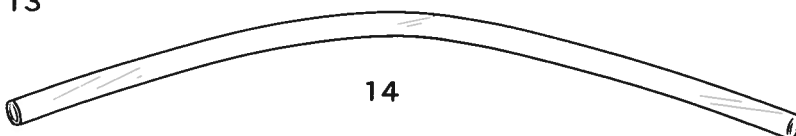

14



15



16

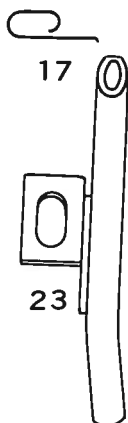

17



18

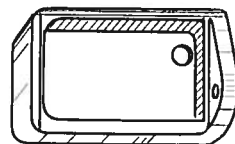

19



20

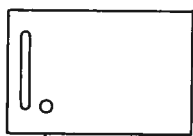

21



22

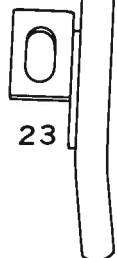

23



25



26



27

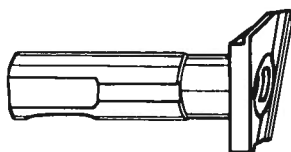

28

24

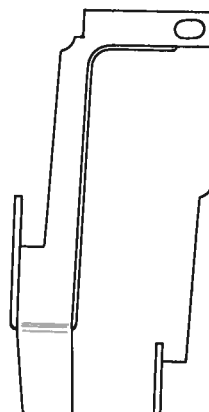

29

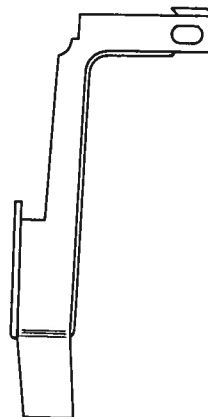

30

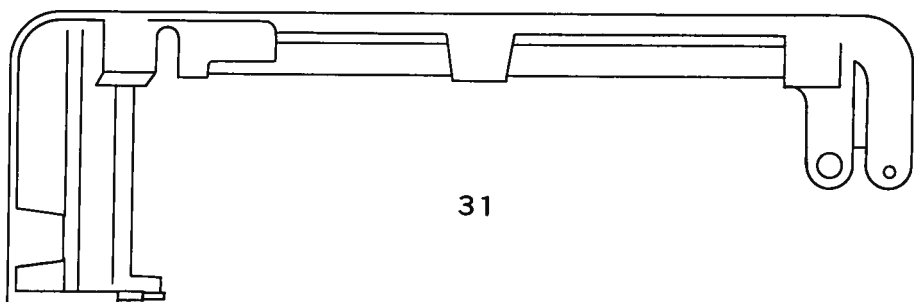

31

**PARTS FOR MODEL DCR-981, 985 & 989 ONLY**  
**DCR-981・985・989 (H・R) 型専用部品**

Ref. No. 参照番号	Parts No. 部品番号	Name 名称	名称	Qt. 数量	Remarks 備考
1	202758	Model plate	型式板	1	DCR-981 only用
	202759	〃 plate	〃	1	DCR-985 only用
	202760	〃 plate	〃	1	DCR-989 only用
2	○202477	Name plate	H, R装置マーク	1	
3	○202476-1	Silicone lubricant reservoir (upper)	シリコンタンク (上)	1	
4	○202476-2	〃 〃 〃 〃 bracket	〃 〃 取付板	1	
5	○202476-3	〃 〃 regulating thumb screw	〃 〃 油量調節棒	1	
6	○202476-4	〃 〃 reservoir cap cover	〃 〃 蓋	1	
7	○ 1216	〃 〃 〃 assembly screw	〃 〃 組立ネジ	2	
8	○ 2193	〃 〃 〃 screw	〃 〃 止ネジ	1	
9	○202461	〃 〃 〃 screw stud	〃 (B) 取付棒	1	
10	202742	〃 〃 wick holding tube	シリコンパイプ (上)	1	
11	202743	〃 〃 〃 〃 〃 cap	〃 〃 〃 蓋	1	
12	202744	〃 〃 〃 〃 〃 retainer	〃 〃 〃 止板	1	
13	1229	〃 〃 〃 〃 〃 〃 screw	〃 〃 〃 〃 止ネジ	1	
14	202751	〃 〃 tube (vinyl)	ビニールパイプ (上)	1	
15	○200633	〃 〃 wick	シリコンパイプフェルト	1	
16	○200155	〃 〃 tube clamp	ビニールパイプ抱パネ	2	
17	202752	Needle thread guide	シリコンパイプ (上) 糸当	1	
18	5077	〃 〃 〃 screw	〃 〃 〃 止ネジ	1	
19	○202455	Silicone lubricant reservoir (lower)	シリコンタンク (A)	1	
20	○ 5117	〃 〃 〃 〃 screw	〃 〃 〃 止ネジ	1	
21	○202456	〃 〃 〃 〃 cap cover	〃 〃 〃 蓋	1	
22	○ 5030	〃 〃 〃 〃 〃 〃 screw	〃 〃 〃 〃 止ネジ	1	
	○202745A	〃 〃 tube, complete with 202746A & 202747A	シリコンパイプ (下) 組	1	{ 202746A, 202747A との組
23	○202746A	〃 〃 tube	シリコンパイプ (下)	1	
24	○202747A	〃 〃 〃 bracket	〃 〃 取付台	1	
25	○ 5091	〃 〃 〃 〃 screw	〃 〃 〃 止ネジ	1	
26	○202472	〃 〃 tube (vinyl)	ビニールパイプ (下)	1	
15	○200633	〃 〃 wick	シリコンパイプフェルト	1	
27	○200155	〃 〃 tube clamp	ビニールパイプ抱パネ	2	
28	○202739	Lower knife holder	下メス台	1	{ Also for DCR-905, 915 & 909 共用
29	202750	Chip guard (left)	前カバー (左)	1	DCR-981 only用
30	202741	〃 guard (left)	〃 〃	1	DCR-985 & 989 only用
	○202466	Cloth plate, complete	大カバー (組)	1	
31	○202467	〃 plate extension	〃 (下)	1	

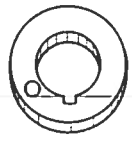

1

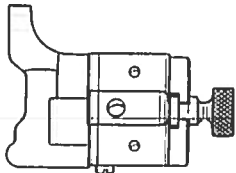

2

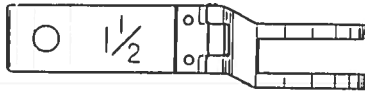

3



4



5

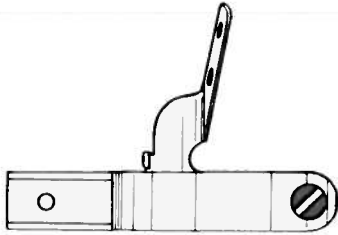

6

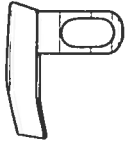

7



8



9

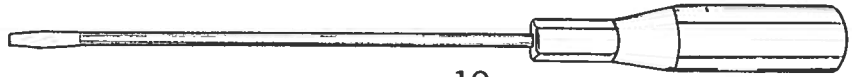

10

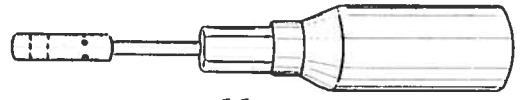

11

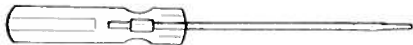

12



14

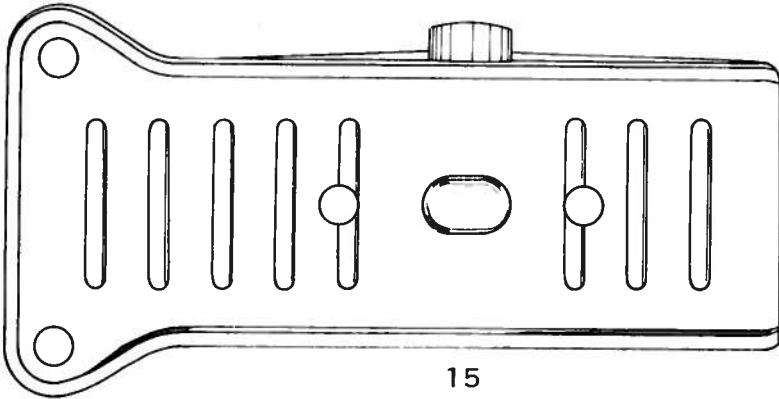

15

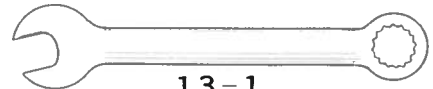

13-1

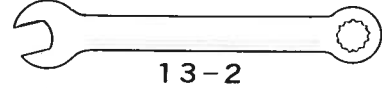

13-2

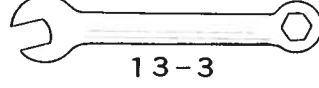

13-3



13-4

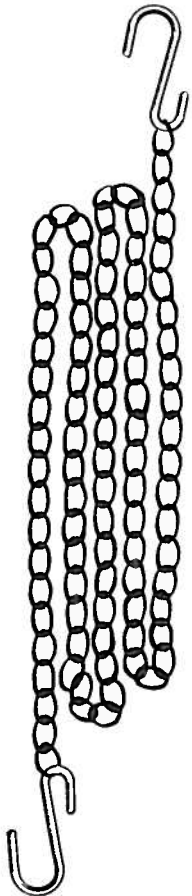

16

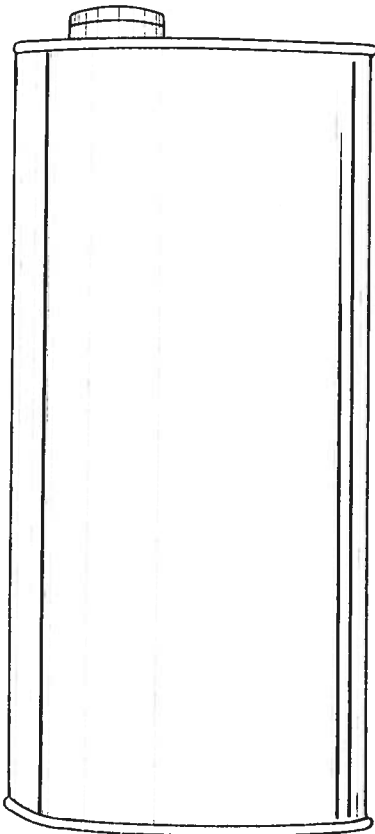

17



18

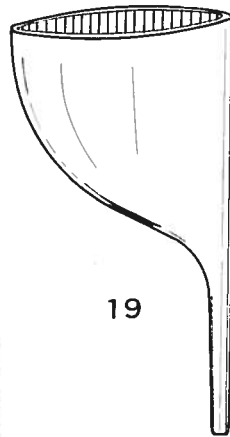

19



20



21



22

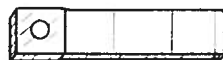

23



24

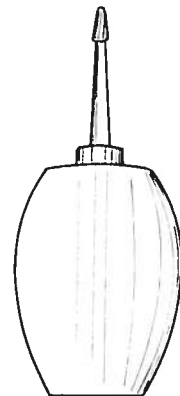

25



ACCESSORIES (1)

付 属 品 (1)

Ref. No. 参照番号	Parts No. 部品番号	Name 名称		Qt. 数量	Remarks 備 考
1	○201103-8	Feed eccentric # 8	送りエキセン # 8	1	DCR-901, 902, 905, 909, 915, 985 & 989 only用
	○201103-14	* eccentric #14	送りエキセン #14	1	
	○201103-6	* eccentric # 6	* # 6	1	
	○201103-12	* eccentric #12	* #12	1	
	○201499	Welt guide, complete with 201206, 201211A, 2905 & 137142	定規(組) { 201206, 201211A, 2905, 137142 との組	1	
2	○201206	* guide holder, complete with 201207B, 201208, 201209, 201210, 5096, 2130x1 & 5057	定規台(組) { 201207B, 201208, 201209, 201210, 5096, 2130x1, 5057 との組	1	DCR-901 & 981 only用
	○201207B	* * * (A)	* (A)	1	
	○201208	* * * (B)	* (B)	1	
	○201209	* * * (C)	* (C)	1	
	○201210	* * * (D)	* (D)	1	
	○ 5096	* * * assembly screw	* 組立ネジ	1	
	○ 2130	* * * regulating screw	* 調節ネジ	4	
	○ 5057	* * * set screw	* 取付ネジ	1	
3	○201211A	* guide	定規羽根	1	
4	○ 2905	* * * screw	* 止ネジ	1	
5	○137142	* * * washer	* * 座金	1	
6	○201500	Cloth guide holder, complete with 201232A, 201233A, 1202 & 137906	当定規台(組) { 211232A, 201233A, 1202, 137906 との組	1	DCR-903 only用
	○201232A	* * * (A) with { 201485, 201191, 5184 & 5071	* (A) { 201485, 201191, 5184, 5071 との組	1	
	○201485	* * * (B)	* (B)	1	
	○201191	* * * * spring	* * 皿バネ	1	
	○ 5184	* * * * screw	* * 止ネジ	1	
	○ 5071	* * * * * nut	* * * ナット	1	
7	○201233A	* guide	当定規	1	
8	○ 1202	* * * screw	* 止ネジ	1	
9	○137906	* * * washer	* * 座金	1	
10	○ 127	Screw driver, large	ネジ廻シ(大)	1	
	○ 128	* * * medium	* (中)	1	
	○ 129	* * * small	* (小)	1	
11	○201227	Socket wrench	ボックスドライバー	1	
12	○201226	Feed eccentric extractor	抜取具	1	
13-1	○130A-9.5	Wrench, 9.5mm	スパナ 9.5mm	1	
13-2	○130A-7	* 7mm	* 7 mm	1	
13-3	○130A-6	* 6mm	* 6 mm	1	
13-4	○130A-5	* 5mm	* 5 mm	1	
14	○ 131	Tweezers	ピンセット	1	
15	○ 121	Treadle	鞆	1	
16	○ 126	* chain	鎖	1	
17	○ 133	Oil container (750cc)	油缶 (750cc)	1	
18	○ 132	Oiler	油差し	1	
19	○ 135A	Funnel	ジョウゴ	1	
20	○202295	Lower knife	下メス	2	
21	DCx1	Needle, # 9	針 # 9	10	DCR-901, 902 & 981 only用 DCR-903, 905, 909, 985 & 989 only用 DCR-915 only用 DCR-905(1.5mm) only用
	DCx1	* #11	* #11	10	
	DCx1	* #14	* #14	10	
	DCx3	* #11	* #11	10	
22	○201486	Threading wire	糸通シ具	1	DCR-901 & 981 tricot (トリコット) only用
23	○202281	Welt guide extension	定規補助羽根	1	
24	○ 2905	* * * * screw	* 止ネジ	1	
25	○	Silicone lubricant container (50cc)	シリコン油 (50cc)	1	DCR-981, 985 & 989 only用

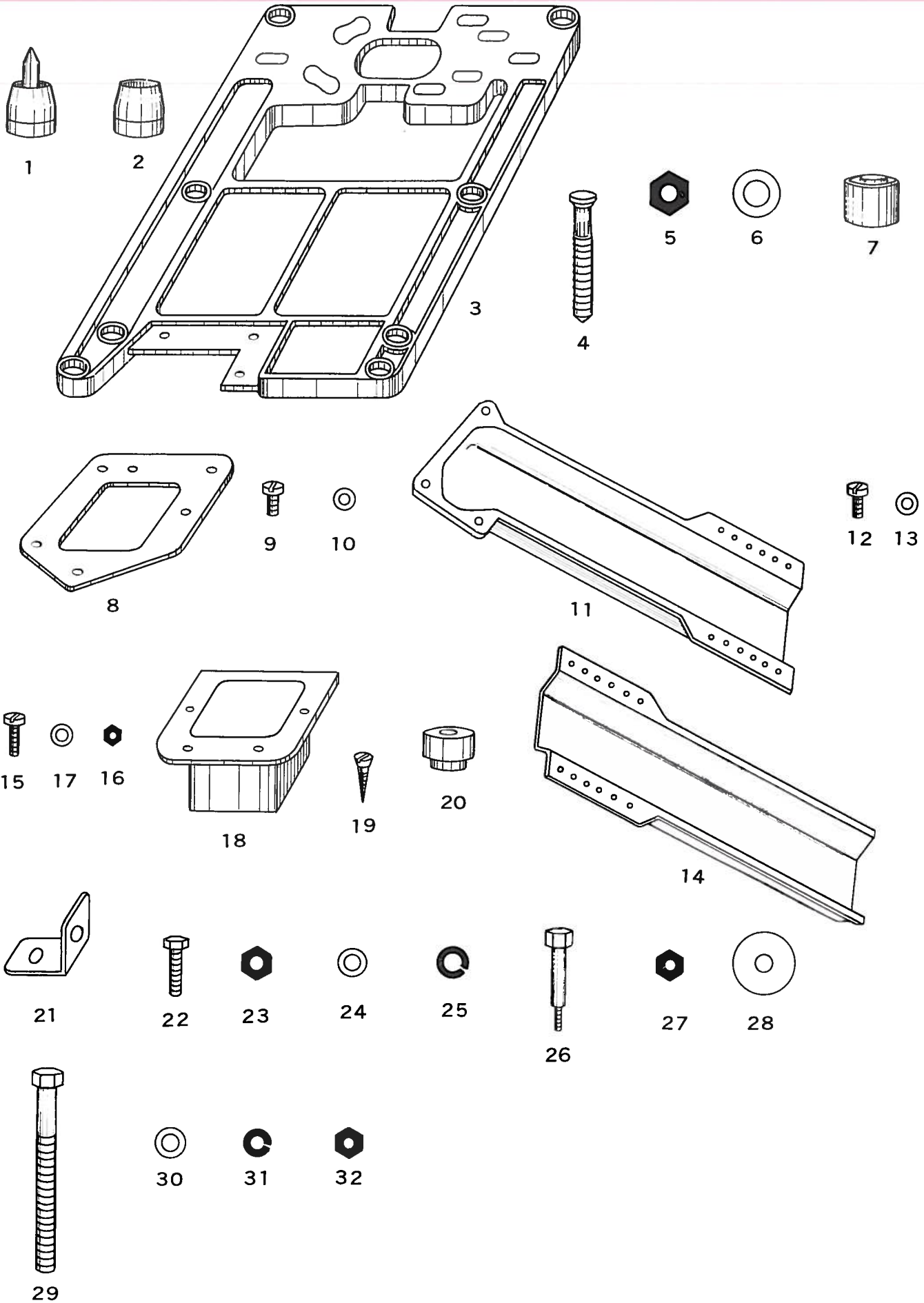

**ACCESSORIES (2) for Semi-submerged Installation**

**付 属 品 (2) (半 沈 据 付 用)**

Ref. No. 参照番号	Parts No. 部品番号	Name 名称	名 称	Qt. 数量	Remarks 備 考
1	○202691	Machine base cushion rubber, with 202692	クッションゴム (A) 組	3	202692との組
	○202692	＊ ＊ ＊ rubber pin	＊ ＊ ＊ ヒン	3	
2	○202761	＊ ＊ ＊ rubber	＊ ＊ ＊ (C)	1	
3	○202697C	＊ rest board	半沈用ベッド取付板	1	
4	○201303	＊ ＊ ＊ hanger bolt	＊ ＊ ＊ ボルト	4	
5	○ 5221	＊ ＊ ＊ ＊ ＊ ＊ nut	＊ ＊ ＊ ＊ ＊ ＊ ナット	4	
6	○202700	＊ ＊ ＊ ＊ ＊ ＊ ＊ washer	＊ ＊ ＊ ＊ ＊ ＊ ＊ 座金	4	
7	○202693A	＊ ＊ ＊ ＊ ＊ ＊ ＊ cushion rubber (lower)	クッションゴム (B)	4	
8	○202715A	Chip chute bracket	半沈用切屑受A取付板	1	
9	○ 5117	＊ ＊ ＊ ＊ ＊ ＊ ＊ screw	＊ ＊ ＊ ＊ ＊ ＊ ＊ 止ネジ	3	
10	○200098	＊ ＊ ＊ ＊ ＊ ＊ ＊ washer	＊ ＊ ＊ ＊ ＊ ＊ ＊ 座金	3	
11	○201348B	＊ ＊ ＊ ＊ ＊ ＊ ＊ chute	＊ ＊ ＊ ＊ ＊ ＊ ＊ A	1	
12	○ 5117	＊ ＊ ＊ ＊ ＊ ＊ ＊ screw	＊ ＊ ＊ ＊ ＊ ＊ ＊ 止ネジ	3	
13	○200098	＊ ＊ ＊ ＊ ＊ ＊ ＊ washer	＊ ＊ ＊ ＊ ＊ ＊ ＊ 座金	3	
14	○201349B	＊ ＊ ＊ ＊ ＊ ＊ ＊ extension	＊ ＊ ＊ ＊ ＊ ＊ ＊ B	1	
15	○ 5118	＊ ＊ ＊ ＊ ＊ ＊ ＊ screw	＊ ＊ ＊ ＊ ＊ ＊ ＊ A, B連結ネジ	4	
16	○ 3011	＊ ＊ ＊ ＊ ＊ ＊ ＊ nut	＊ ＊ ＊ ＊ ＊ ＊ ＊ ナット	4	
17	○200098	＊ ＊ ＊ ＊ ＊ ＊ ＊ washer	＊ ＊ ＊ ＊ ＊ ＊ ＊ ＊ ＊ 座金	8	
18	○201346A	＊ ＊ ＊ ＊ ＊ ＊ ＊ top	＊ ＊ ＊ ＊ ＊ ＊ ＊ C	1	
19	○ 175	＊ ＊ ＊ ＊ ＊ ＊ ＊ wood screw	＊ ＊ ＊ ＊ ＊ ＊ ＊ 止ネジ	4	
20	○202765	Machine rest board cushion rubber (upper)	クッションゴムD	4	
21	○202768	＊ ＊ ＊ ＊ ＊ ＊ ＊ hanger bracket	＊ ＊ ＊ ＊ ＊ ＊ ＊ ベッド取付板用金具	8	
22	○ 5296	＊ ＊ ＊ ＊ ＊ ＊ ＊ ＊ ＊ screw	＊ ＊ ＊ ＊ ＊ ＊ ＊ ＊ ＊ 用ボルト	4	
23	○ 5297	＊ ＊ ＊ ＊ ＊ ＊ ＊ ＊ ＊ ＊ ＊ nut	＊ ＊ ＊ ＊ ＊ ＊ ＊ ＊ ＊ ナット	4	
24	○202769	＊ ＊ ＊ ＊ ＊ ＊ ＊ ＊ ＊ ＊ ＊ washer	＊ ＊ ＊ ＊ ＊ ＊ ＊ ＊ ＊ ＊ ＊ ワッシャー	8	
25	○201477	＊ ＊ ＊ ＊ ＊ ＊ ＊ ＊ ＊ ＊ ＊ spring washer	＊ ＊ ＊ ＊ ＊ ＊ ＊ ＊ ＊ ＊ ＊ バネ座金	4	
26	○202766	＊ ＊ ＊ ＊ ＊ ＊ ＊ ＊ ＊ ＊ ＊ set bolt	＊ ＊ ＊ ＊ ＊ ＊ ＊ ＊ ＊ ＊ ＊ ベッド取付板止ネジ	4	
27	○ 5298	＊ ＊ ＊ ＊ ＊ ＊ ＊ ＊ ＊ ＊ ＊ nut	＊ ＊ ＊ ＊ ＊ ＊ ＊ ＊ ＊ ＊ ＊ ナット	4	
28	○202767	＊ ＊ ＊ ＊ ＊ ＊ ＊ ＊ ＊ ＊ ＊ washer	＊ ＊ ＊ ＊ ＊ ＊ ＊ ＊ ＊ ＊ ＊ 座金	4	
29	○ 5302	Motor hanger bolt	＊ ＊ ＊ ＊ ＊ ＊ ＊ ＊ ＊ ＊ ＊ モーター取付ボルト	3	
30	○202769	＊ ＊ ＊ ＊ ＊ ＊ ＊ ＊ ＊ ＊ ＊ washer	＊ ＊ ＊ ＊ ＊ ＊ ＊ ＊ ＊ ＊ ＊ 座金	6	
31	○201477	＊ ＊ ＊ ＊ ＊ ＊ ＊ ＊ ＊ ＊ ＊ spring washer	＊ ＊ ＊ ＊ ＊ ＊ ＊ ＊ ＊ ＊ ＊ バネ座金	3	
32	○ 5297	＊ ＊ ＊ ＊ ＊ ＊ ＊ ＊ ＊ ＊ ＊ nut	＊ ＊ ＊ ＊ ＊ ＊ ＊ ＊ ＊ ＊ ＊ 用ナット	3	



Parts No.	Page	Ref. No.	Parts No.	Page	Ref. No.	Parts No.	Page	Ref. No.	Parts No.	Page	Ref. No.	Parts No.	Page	Ref. No.
部品番号	頁	参照番号	部品番号	頁	参照番号	部品番号	頁	参照番号	部品番号	頁	参照番号	部品番号	頁	参照番号
201230B	27	11	201425	19	5	202602	3	6	202680	23	12	202769	33	30
201232A	31	(6)	201426	19	13	202603B	3	27	202682	15	22	202827	7	18
201233A	31	7	201428	23	7	202601	3	32	202683	15	2	202828	7	28
201235	23	(2)	201429	19	6	202605	5	1	202684	25	5-1	202828	27	17
201236	23	(2)	201436	3	21	202606	5	5	202685	25	5-2	202810	25	11
201243A	25	32	201437	3	22	202607	5	14	202686	25	30	202849	7	38
201243A	27	21	201438A	9	16	202608	5	17	202686	27	19	202849	9	28
201261A	27	31	201439A	5	65	202609	5	18	202687	3	19	202861	3	34
201265B	25	7	201441	25	19	202610	5	21	202689	23	3	202865	21	16
201265B	27	12	201441	27	2	202611	5	23	202691	33	1	202868	15	31
201269	27	28	201447	11	29	202613	5	35	202692	33	(1)	202875	7	43
201270A	25	9	201452	3	24	202614	5	37	202693A	33	7	202875	9	37
201270A	27	14	201453A	5	48	202615	5	39	202697C	33	3	204303	33	4
201288A	17	1	201454A	25	25	202616	5	41	202700	33	6			
201289A	17	(1)	201454A	27	8	202617	5	(1)	202701	23	15			
201290A	17	(1)	201458A	27	27	202618	5	(1)	202702	25	20-2			
201291	17	(1)	201461	27	32	202619A	7	1	202703	9	18			
201292	17	(1)	201473A	25	2	202622B	7	5	202704	5	32			
201293A	17	3	201477	33	25	202623A	7	7	202705	5	24			
201294	17	5	201477	33	31	202625	7	19	202706A	5	29			
201295	17	6	201482	5	58	202626A	7	16	202707	5	31			
201296	17	7	201482	7	36	202627A	7	21	202709A	7	9			
201297	17	8	201482	9	26	202628B	7	22	202710A	7	10			
201298	17	10	201481	17	(2)	202629B	7	24	202711A	5	3			
201299	17	13	201485	31	(6)	202631A	7	14	202711A	7	3			
201300	17	15	201486	31	22	202632A	23	(2)	202711A	13	3			
201301	17	16	201487	19	19	202633	9	29	202712A	7	12			
201302	17	17	201499	31	(2)	202634	11	4	202713	7	8			
201302	19	23	201500	31	6	202635	13	13	202715A	33	8			
201303	17	18	201518	17	(1)	202636	13	16	202716	3	3			
201304	17	20	202081	7	6	202637A	13	20	202719	25	28			
201308	15	11	202081	7	27	202638A	13	22	202720B	3	15			
201310A	27	16	202200	11	23	202639	15	1	202722A	17	12			
201311	17	24	202201A	11	31	202640	15	4	202724	5	50			
201315	17	30	202202	11	35	202641	15	13	202726A	3	45			
201316	17	31	202203	11	36	202642	15	14	202727	17	22			
201318A	23	26	202278	5	55	202643	15	17	202728	25	26			
201319	17	19	202278	7	33	202644	15	24	202728	27	9			
201320	17	21	202278	9	23	202645	15	25	202737	3	25			
201325B	19	24	202281	31	23	202646	15	26	202739	25	31			
201328	19	14	202286	5	63	202647A	15	28	202739	27	20			
201329	19	15	202286	9	6	202648A	21	1	202739	29	28			
201330	3	10	202287	19	21	202649	21	2	202741	29	30			
201331B	19	17	202288	3	42	202650	21	25	202742	29	10			
201335	19	18	202295	13	25	202651	21	27	202743	29	11			
201338	17	23	202295	31	20	202652	23	1	202744	29	12			
201339	17	(2)	202297	5	64	202653	23	2	202745A	29	(2)			
201340	17	(2)	202351	3	20	202654A	23	8	202746A	29	23			
201341	17	25	202455	29	19	202655	23	10	202747A	29	24			
201342B	17	27	202456	29	21	202657B	23	24	202748	23	28			
201343B	17	(2)	202461	29	9	202658A	19	27	202749	25	23			
201344B	17	(2)	202466	29	(1)	202660	23	16	202749	27	6			
201345A	17	28	202467	29	31	202662	3	16	202750	29	29			
201346A	33	18	202472	29	26	202663D	3	17	202751	29	14			
201348B	33	11	202473	7	26	202664	3	11	202752	29	17			
201349B	33	14	202474	5	47	202665	25	1	202753	25	18			
201356	5	6	202476-1	29	3	202666	25	4	202755	25	29			
201360	5	11	202476-2	29	4	202667	25	17	202755	27	18			
201378A	11	7	202476-3	29	5	202668	27	1	202756	15	7			
201379B	25	14	202476-4	29	6	202669	25	5-3	202757	7	14			
201379B	27	10	202477	29	2	202671	25	13	202758	29	1			
201380	13	1	202478	5	53	202672	25	21	202759	29	(1)			
201381	13	5	202478	25	34	202673	25	(2)	202760	29	(1)			
201388	15	16	202478	27	23	202673	27	4	202761	33	2			
201395	15	29	202479	7	31	202674	25	20-1	202762	23	(2)			
201396A	25	27	202480	9	21	202675	25	20-3	202765	33	20			
201404	23	5	202491	5	51	202675	27	3	202766	33	26			
201422	19	1	202589	15	5	202677	27	25	202767	33	28			
201423	19	2	202600A	3	1	202678	27	26	202768	33	21			
201424	19	4	202601	3	2	202679	27	29	202769	33	24			

