



# PEGASUS

INDUSTRIAL

SEWING MACHINE

## PARTS LIST

FOR MODEL

**DCR-801**

**DCR-802 DCR-803 DCR-805 DCR-809**

**DCR-810 DCR-881 DCR-885 DCR-889**

**HIGH SPEED OVERLOCK STITCH MACHINE**

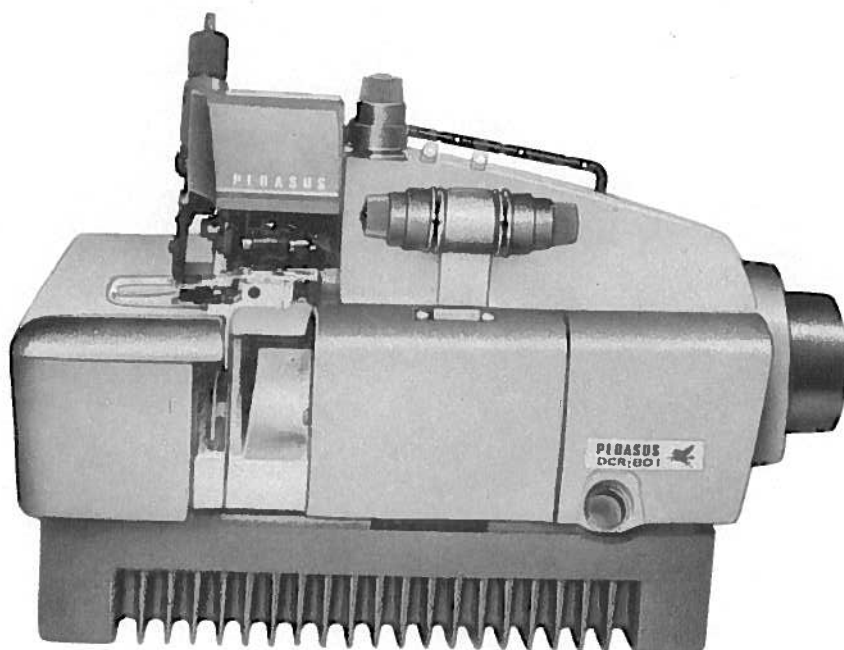

**MIMA SEWING MACHINE CO., LTD.  
PEGASUS SEWING MACHINE MFG. CO., LTD.**

**OSAKA - JAPAN - TOKYO**



## IN ORDERING PARTS

This list has been arranged to simplify ordering repair parts for DCR-800 series machines, on the basis of model DCR-801.

Various sections of the mechanisms are shown on each page. On the page opposite the illustrations will be found a listing of the parts with their reference numbers, parts numbers, names, the number of pieces required and the remarks.

At the back of this list, a numerical index of all parts is shown. This will facilitate locating the illustration and descriptions when only the part number is known.

Where parts for model DCR-801 and other DCR-800 series machines are not the same, the difference for each model is shown on the pages 24 to 31.

Parts whose numbers are marked with an asterisk (\*), e.g. \*202617, ref. No. 20, page 5, are also used for some of other DCR-800 series, which are referred to the remarks column. When a part is used for all DCR-800 series covered by page 2 to 23 of this list, no machine is mentioned in the remarks column.

In ordering parts from this list, the part number MUST be quoted exactly as it is shown in the second column on the page opposite the illustrations. Reference number should never be used in ordering parts.

## 部品表御利用に際して

本部品表は DCR-801型を基本型に DCR-800シリーズミシンの修理用部品を容易に御利用頂ける様編集されている。

機構別に各頁に収録され、部品図解頁(左開き)の反対頁(右開き)には参照番号、部品番号、名称、使用数量、備考欄の順で記載されている。

本部品表の最終頁(36、37頁)には部品番号索引表を付し、部品番号のみでその図解、名称等が容易に引き出せる。

DCR-801型用と異なる他の DCR-800シリーズ専用部品は24頁から31頁にわたり各機種毎に分類、記載されている。

2頁から23頁にわたり備考欄に表示なき部品は全ての DCR-800シリーズに共通で、特定の機種のみを使用される部品はその都度部品番号に\*印を付し(例 \*202617、参照番号20、5頁)備考欄に適用機種名を明記している。

本部品表に基き部品御注文の際、参照番号は絶対に使用せず必ず部品番号のみを明示下さい。

## CONTENTS

## 目次

	PAGE 頁
MACHINE ARM-BED & CRANKSHAFT MECHANISM.....アーム・ベッド主軸機構.....	2 ~ 3
NEEDLE DRIVE MECHANISM.....針振り機構.....	4 ~ 5
RIGHT LOOPER DRIVE MECHANISM.....大ルーバー機構.....	6 ~ 7
LEFT LOOPER DRIVE MECHANISM.....小ルーバー機構.....	8 ~ 9
MAIN & DIFFERENTIAL FEEDING MECHANISM.....送り機構.....	10 ~ 11
UPPER & LOWER KNIFE MECHANISM.....上・下メス機構.....	12 ~ 13
PRESSER FOOT & LIFTING MECHANISM.....押エ機構.....	14 ~ 15
PUMP & LUBRICATING MECHANISM (1).....ポンプ・給油機構 (1).....	16 ~ 17
PUMP & LUBRICATING MECHANISM (2).....ポンプ・給油機構 (2).....	18 ~ 19
CLOTH PLATE & MISCELLANEOUS COVERS.....カバー・外装機構 (1).....	20 ~ 21
MAIN FRAME & MISCELLANEOUS COVERS.....カバー・外装機構 (2).....	22 ~ 23
PARTS FOR MODEL DCR-802, 803 & 805 ONLY.....DCR-802, 803, 805型専用部品.....	24 ~ 25
PARTS FOR MODEL DCR-809 ONLY.....DCR-809型専用部品.....	26 ~ 27
PARTS FOR MODEL DCR-810 ONLY.....DCR-810型専用部品.....	28 ~ 29
PARTS FOR MODEL DCR-881, 885 & 889 ONLY.....DCR-881, 885, 889型専用部品.....	30 ~ 31
ACCESSORIES (1).....付属品 (1).....	32 ~ 33
ACCESSORIES (2) for Semi-submerged Installation.....付属品 (2) (半沈据付用).....	34 ~ 35
NUMERICAL INDEX OF PARTS.....部品番号索引.....	36 ~ 37

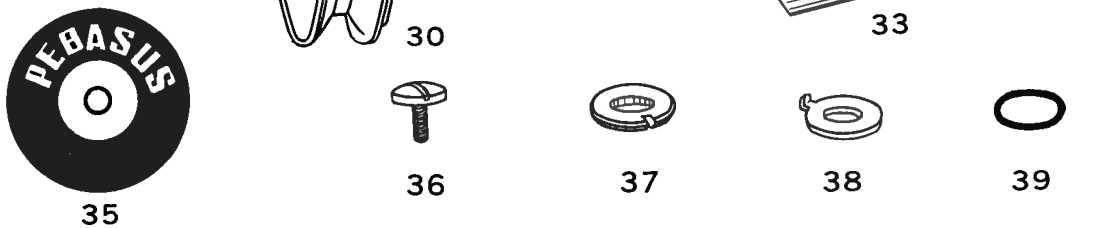
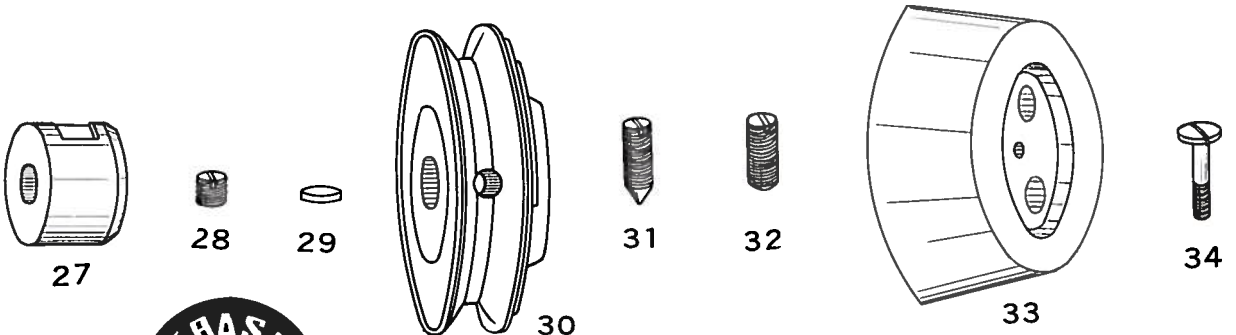
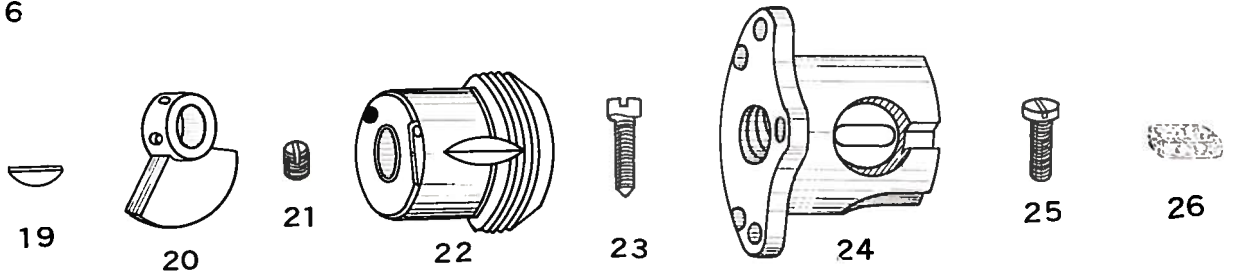
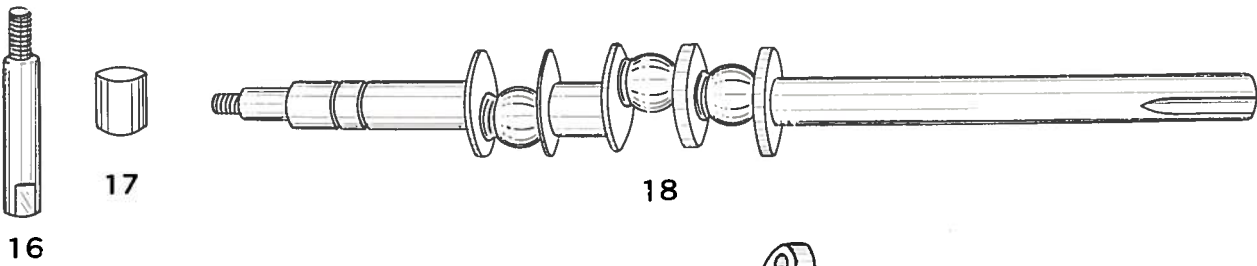
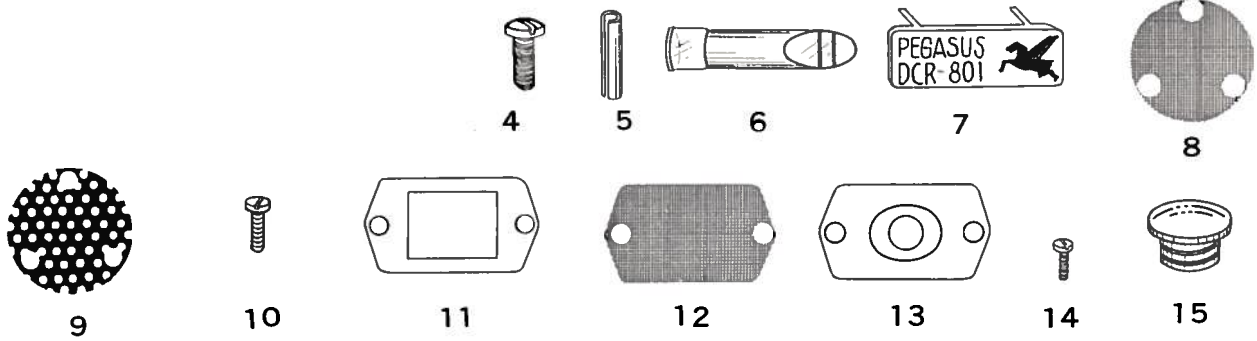
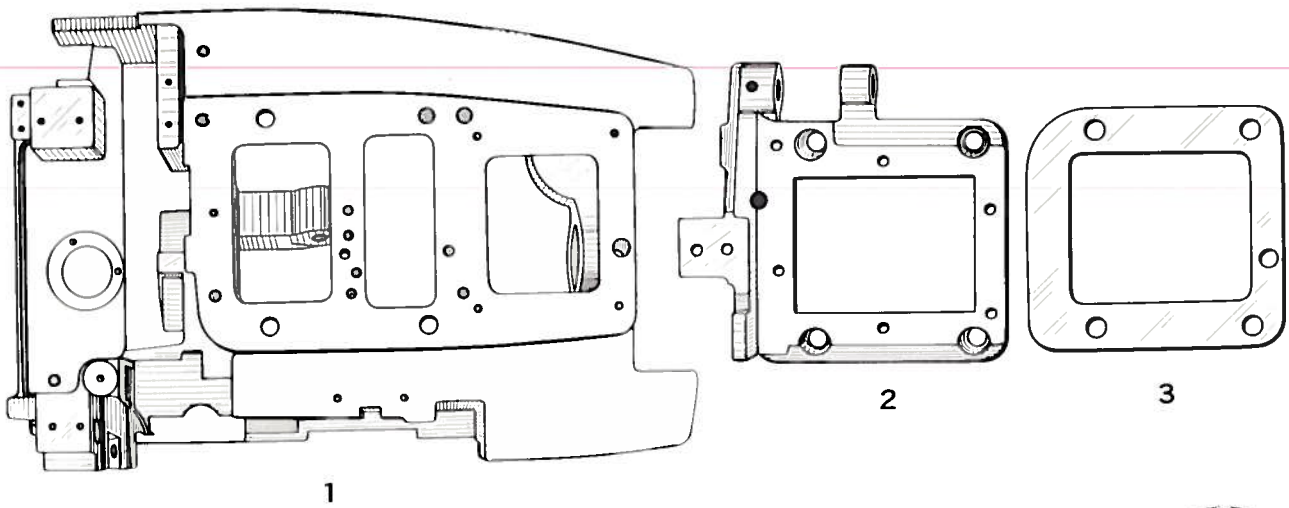

# MACHINE ARM-BED & CRANKSHAFT MECHANISM

## アーム・ベッド主軸機構

Ref. No. 参照番号	Parts No. 部品番号	Name	名称	Qty. 数量	Remarks 備考
1	202800	Machine bed	ベッド	1	
2	202501	* arm	アーム	1	
3	202371	* * gasket	* パッキン	1	
4	5078	* * screw	* 取付ネジ	4	
5	201002	* * hinge pin	* 取付ロックピン	2	
6	201330	Oil sight gauge	オイルゲージ	1	
7	202801	Model plate	型式板	1	
8	201004	Oil filter screen (left)	油濾金網 (A)	1	
9	201005	* strainer	油濾金板 (A)	2	
10	1175-2	* * screw	* * * 止ネジ	3	
11	202720B	* filter screen (front) gasket	* * (B) パッキン	1	
12	202662	* * * (front)	* 金網 (B)	1	
13	202663B	* * * * plate	* 金板 (B)	1	
14	1175-2	* * * * * screw	* * * 止ネジ	2	
15	202687	Plug screw	加工穴蓋	2	
16	202354	Machine bed bottom pin	ベッド足ピン	4	
17	202863	* * stopper	ベッド加工穴栓	1	
18	202822 A	Crankshaft	クランクシャフト	1	
19	201009	* key	* キー	1	
20	201010A	* counterweight	カウンターウェイト	1	
21	5060	* * screw	* 止ネジ	2	
22	201011C	* bushing, with 201016	右大ブッシュ (組) 201016との組	1	
23	2317	* * screw	* (組) 止ネジ	1	
24	202821B	* flanged bushing, with 201016	左大ブッシュ (組) 201016との組	1	
25	5136	* * * screw	* (組) 止ネジ	3	
26	202864	* * * oil wick	* * 給油フェルト	1	
27	201212A	* bushing (intermediate)	中間ブッシュ	1	
28	2022-3	* * * screw	* 止ネジ	1	
29	202870	* * * washer	* * 座金	1	
30	201017A	Pulley	プーリー	1	
31	5080	* position screw	* 止ネジ (先行)	1	
32	5081	* screw	* * (先ナシ)	1	
33	201018B	* cap	* 蓋	1	
34	5010	* * screw	* * 止ネジ	3	
35	202288	* * name plate	* * 銘板	1	
36	5211	* * * * screw	* * * 止ネジ	1	
37	201021A	* thrust collar	プーリー用スラストカラー	1	
38	202726A	* * * washer	* * 座金	1	
39	201022	* "O" ring	* "O" リング	2	

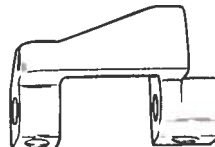
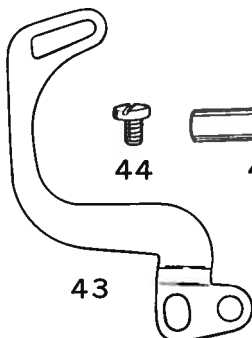
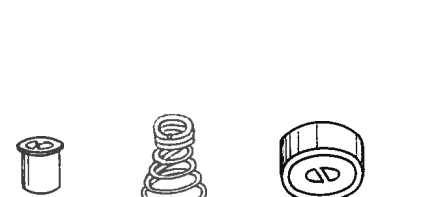
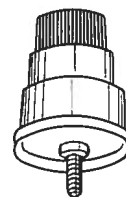
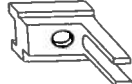
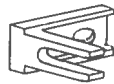
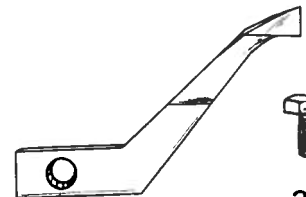
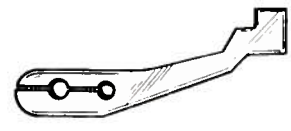
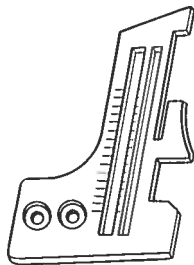
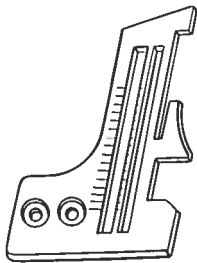
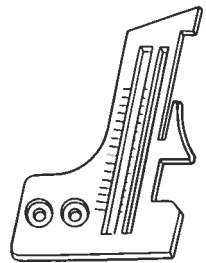
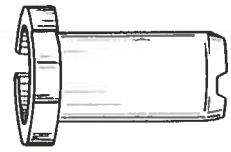
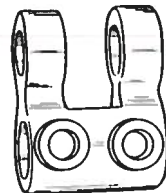
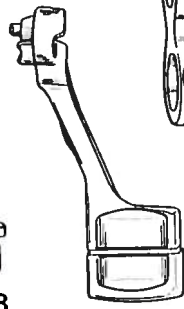
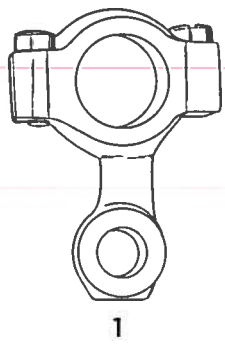

# NEEDLE DRIVE MECHANISM

## 針 振 り 機 構

Ref. No. 参照番号	Parts No. 部品番号	Name	名 称	Qt. 数量	Remarks 備 考
1	201023	Needle driving rod	針振ロッド	1	
2	2213-1	〃 〃 〃 screw	〃 蓋止ネジ	2	
3	202711A	〃 〃 〃 hinge pin	〃 ビン	1	
4	1157	〃 〃 〃 〃 〃 screw	〃 〃 〃 止ネジ	1	
5	201025	〃 〃 〃 crank	針振クランク	1	
6	5084	〃 〃 〃 screw	〃 止ネジ	2	
7	202825	〃 〃 〃 shaft	針振シャフト	1	
8	201027	〃 〃 〃 flanged bushing	〃 ブッシュ (前)	1	
9	1157	〃 〃 〃 〃 〃 screw	〃 〃 〃 止ネジ	1	
10	201028	〃 〃 〃 bushing	〃 〃 (後)	1	
11	1157	〃 〃 〃 〃 〃 screw	〃 〃 〃 止ネジ	1	
12	201029	〃 〃 〃 thrust collar	〃 スラストカラー	1	
13	5084	〃 〃 〃 〃 〃 screw	〃 〃 〃 止ネジ	2	
14	*201030 A	〃 〃 〃 arm	針 腕	1	DCR-801, 802, 803 & 881 only 用
15	5002	〃 〃 〃 clamp screw	〃 抱締ネジ	1	
16	*201031 A	〃 〃 〃 clamp	針押エ	1	DCR-801, 802, 803 & 881 only 用
17	*201032	〃 〃 〃 screw stud	〃 止ネジ	1	
18	3044	〃 〃 〃 〃 nut	〃 〃 ナット	1	
19	*202616	〃 〃 〃 plate (2.0mm seam width)	針 板 (縫巾 2.0mm)	1	DCR-801, 802 & 881 only 用
20	*202617	〃 〃 〃 plate (3.0mm seam width)	〃 (縫巾 3.0mm)	1	
21	*202618	〃 〃 〃 plate (4.0mm seam width)	〃 (縫巾 4.0mm)	1	
22	4009-1	〃 〃 〃 screw	〃 止ネジ	2	
23	201034A	〃 〃 〃 key	〃 キー	1	
24	5053	〃 〃 〃 screw	〃 〃 止ネジ	1	
25	*201248B	〃 〃 〃 guard (upper)	針 受 (A)	1	DCR-801, 802, 803 & 881 only 用
26	*201249B	〃 〃 〃 guard (lower)	〃 (B)	1	
27	5088	〃 〃 〃 screw	〃 止ネジ	2	
28	202491	〃 〃 〃 (upper) bracket	〃 (A) 取付台	1	
29	202492	〃 〃 〃 (lower) bracket	〃 (B) 〃	1	
30	1175-3	〃 〃 〃 bracket screw	〃 取付台止ネジ	2	
31	202478	〃 〃 〃 thread tension, complete with 201035A, 202278, 201037, 201039, 201482x2 & 5082	針糸調子 (組) 201035A, 202278, 201037, 201039, 201482x2, 5082との組	1	
32	201035A	〃 〃 〃 thread tension regulating thumb nut	針糸調子ナット	1	
33	202278	〃 〃 〃 spring bushing	〃 樽ナット止パイプ	1	
34	201037	〃 〃 〃 spring	〃 バネ (強)	1	
35	201039	〃 〃 〃 〃 cap	〃 〃 受皿	1	
36	201482	〃 〃 〃 disc	〃 皿	2	
37	5082	〃 〃 〃 screw stud	〃 樽	1	
38	3044	〃 〃 〃 〃 〃 nut	〃 〃 止ナット	1	
39	201047 B	Thread guide	上糸道 (大)	1	
40	202286	〃 〃 〃 nut washer	〃 〃 止ナットバネ座金	2	
41	202297	〃 〃 〃 nut	〃 〃 止ナット	2	
42	201048 A	Needle thread eyelet	上糸道	1	
43	202826	〃 〃 〃 take-up	針糸捌キ	1	
44	1229	〃 〃 〃 screw	〃 止ネジ	2	
45	*201012	〃 〃 〃 tube	針糸道パイプ	1	DCR-801, 802, 803, 805, 809 & 810 only 用
46	5109	〃 〃 〃 screw	〃 止ネジ	1	
47	*201044	〃 〃 〃 take-up eyelet, with 201015 & 201046	〃 (組) 201015, 201046との組	1	DCR-801, 802 & 803 only 用
48	5109	〃 〃 〃 eyelet screw	〃 (組) 止ネジ	1	
49	201043	〃 〃 〃 tube bracket	〃 パイプ取付台	1	
50	1175-2	〃 〃 〃 〃 〃 screw	〃 〃 〃 止ネジ	2	
51	*UOx151	Needle #9	針 #9	1	DCR-801, 802 & 881 only 用



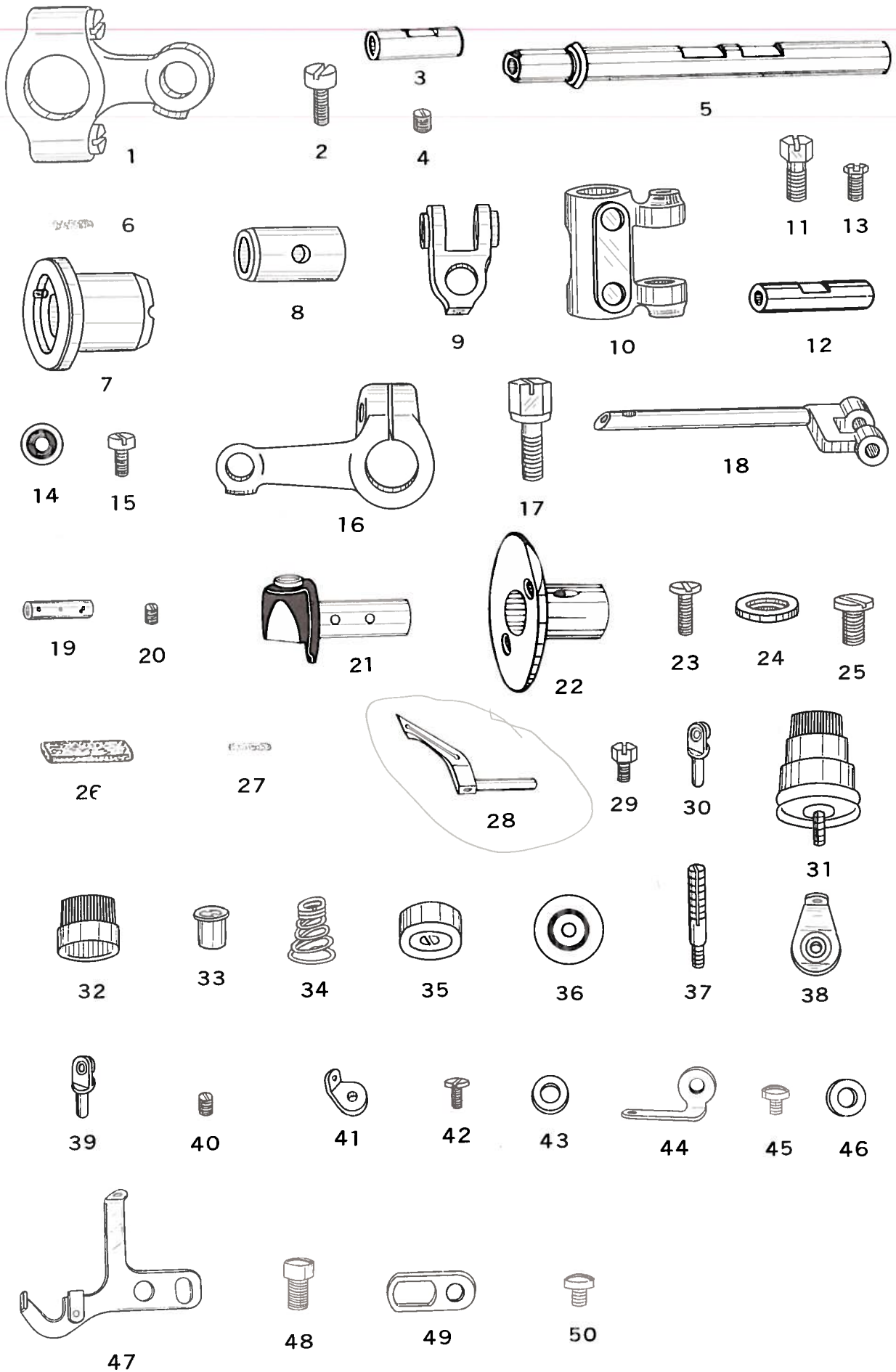



## RIGHT LOOPER DRIVE MECHANISM

### 大 ル ー パ ー 機 構

Ref. No. 参照番号	Parts No. 部品番号	Name	名 称	Qt. 数量	Remarks 備 考
1	202619A	Right looper connecting rod	大ルーバーロッド	1	
2	5002	〃 〃 〃 〃 screw	〃 〃 蓋ネジ	2	
3	202711A	〃 〃 〃 〃 hinge pin	〃 〃 ビン	1	
4	1457-1	〃 〃 〃 〃 〃 〃 screw	〃 〃 〃 止ネジ	1	
5	202622B	〃 〃 lever shaft	大ルーバー台軸	1	
6	202081	〃 〃 〃 〃 oil wick	〃 〃 給油フェルト	1	
7	202623A	〃 〃 〃 〃 flanged bushing	〃 〃 ブッシュ (前)	1	
8	202713	〃 〃 〃 〃 bushing	〃 〃 (後)	1	
9	202709A	〃 〃 connecting rod crank	大ルーバーロッド連結桿	1	
10	202710A	〃 〃 lever shaft crank	大ルーバー後クランク	1	
11	2022-4	〃 〃 〃 〃 〃 screw	〃 〃 止ネジ	2	
12	202712A	〃 〃 〃 〃 〃 hinge pin	〃 〃 ビン	1	
13	5081	〃 〃 〃 〃 〃 〃 screw	〃 〃 〃 止ネジ	1	
14	202757	〃 〃 〃 〃 〃 〃 thrust washer	〃 〃 〃 スラストワッシャー	1	
15	1216	〃 〃 〃 〃 〃 〃 〃 〃 screw	〃 〃 〃 〃 止ネジ	1	
16	202626A	〃 〃 lever	大ルーパークランク	1	
17	5219	〃 〃 〃 screw	〃 〃 抱締ネジ	1	
18	202827	〃 〃 bar	大ルーバー台	1	
19	202625	〃 〃 〃 hinge pin	〃 〃 ビン	1	
20	5146	〃 〃 〃 〃 〃 screw	〃 〃 〃 止ネジ	1	
21	202627A	〃 〃 〃 guide	〃 〃 案内	1	
22	202628B	〃 〃 〃 〃 flanged bushing	〃 〃 〃 ブッシュ	1	
23	1175-2	〃 〃 〃 〃 〃 〃 screw	〃 〃 〃 〃 止ネジ	2	
24	202629B	〃 〃 〃 〃 thrust washer	〃 〃 〃 スラストワッシャー	1	
25	5216B	〃 〃 〃 〃 〃 〃 screw	〃 〃 〃 〃 止ネジ	1	
26	202473	〃 〃 〃 〃 oil wick (large)	〃 〃 〃 給油フェルト (大)	1	
27	202081	〃 〃 〃 〃 〃 wick (small)	〃 〃 〃 (小)	1	
28	*202874	〃 looper	大ルーバー #1	1	DCR-801, 802, 805 & 885 only 用
29	5220	〃 〃 screw	〃 〃 止ネジ	1	
30	201048A	〃 〃 thread eyelet (upper)	上 糸 道	1	
31	202479	〃 〃 thread tension, complete with 201035A, 202278, 201068, 201039, 201482x2 & 5082	大ルーバー糸調子 (組) 201035A, 202278, 201068, 201039, 201482x2, 5082との組	1	
32	201035A	〃 looper thread tension regulating thumb nut	大ルーバー糸調子ナット	1	
33	202278	〃 〃 〃 〃 spring bushing	〃 〃 棒ナット止パイプ	1	
34	201068	〃 〃 〃 〃 spring	〃 〃 バネ (弱)	1	
35	201039	〃 〃 〃 〃 〃 cap	〃 〃 受皿	1	
36	201482	〃 〃 〃 〃 disc	〃 〃 皿	2	
37	5082	〃 〃 〃 〃 screw stud	〃 〃 棒	1	
38	202849	〃 〃 〃 〃 guide	〃 〃 台	1	
39	201048A	〃 〃 〃 〃 eyelet (lower)	前 糸 道	1	
40	1459	〃 〃 〃 〃 〃 screw	〃 〃 〃 止ネジ	1	
41	201089	〃 〃 〃 〃 guide (upper)	大ルーバー糸道 (C)	1	
42	2921	〃 〃 〃 〃 〃 screw	〃 〃 〃 止ネジ	1	
43	202875	〃 〃 〃 〃 〃 〃 washer	〃 〃 〃 〃 座金	1	
44	202859	〃 〃 〃 〃 〃 guide (lower)	〃 〃 (A)	1	
45	2921	〃 〃 〃 〃 〃 〃 screw	〃 〃 〃 止ネジ	1	
46	202875	〃 〃 〃 〃 〃 〃 washer	〃 〃 〃 〃 座金	1	
47	202829	〃 〃 〃 〃 take-up	大ルーバー糸捌き	1	
48	5064	〃 〃 〃 〃 〃 screw	〃 〃 止ネジ	1	
49	202858	〃 〃 〃 〃 〃 bracket	〃 〃 取付台	1	
50	2921	〃 〃 〃 〃 〃 〃 screw	〃 〃 〃 止ネジ	1	

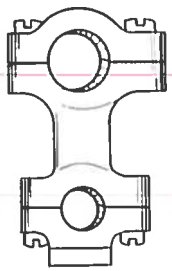

1



2



3



4



5



6

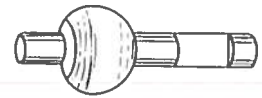

7



8

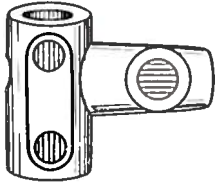

9



10



11

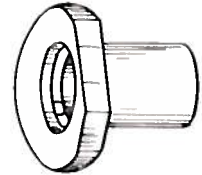

12



13



14



15

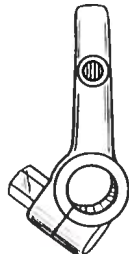

16



17

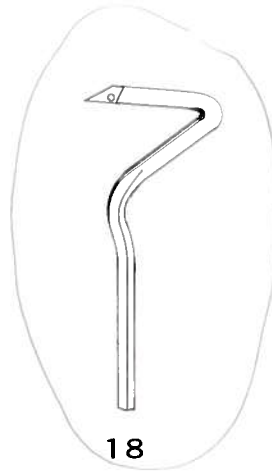

18



19



20

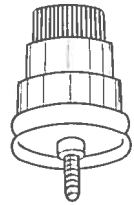

21



22



23



24



25



26



27



28



29



30



31



32



33



34



35



36



37



38



39



40



41



42

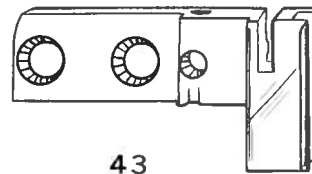

43



44

# LEFT LOOPER DRIVE MECHANISM

## 小 ル ー バ ー 機 構

Ref. No. 参照番号	Parts No. 部品番号	Name	名 称	Qt. 数量	Remarks 備 考
1	201073B	Left looper connecting rod	小ルーバーロッド	1	
2	1170-1	＊ ＊ ＊ ＊ screw (small)	＊ ＊ ＊ ＊ 止ネジ (小)	2	
3	5002	＊ ＊ ＊ ＊ screw (large)	＊ ＊ ＊ ＊ (大)	2	
4	201074	＊ ＊ ＊ ＊ ＊ ＊ ＊ ＊ guide	＊ ＊ ＊ ＊ ＊ ＊ ＊ ＊ 振れ止め	1	
5	1156	＊ ＊ ＊ ＊ ＊ ＊ ＊ ＊ screw	＊ ＊ ＊ ＊ ＊ ＊ ＊ ＊ 止ネジ	1	
6	202286	＊ ＊ ＊ ＊ ＊ ＊ ＊ ＊ ＊ ＊ washer	＊ ＊ ＊ ＊ ＊ ＊ ＊ ＊ ＊ ＊ バネ座金	1	
7	201075	＊ ＊ ＊ ＊ ＊ ＊ ＊ ＊ ＊ ＊ ball stud	＊ ＊ ＊ ＊ ＊ ＊ ＊ ＊ ＊ ＊ 球	1	
8	5018	＊ ＊ ＊ ＊ ＊ ＊ ＊ ＊ ＊ ＊ screw	＊ ＊ ＊ ＊ ＊ ＊ ＊ ＊ ＊ ＊ 止ネジ	1	
9	201079A	＊ ＊ ＊ ＊ ＊ ＊ ＊ ＊ ＊ ＊ bar crank	＊ ＊ ＊ ＊ ＊ ＊ ＊ ＊ ＊ ＊ 小ルーバークランク	1	
10	5018	＊ ＊ ＊ ＊ ＊ ＊ ＊ ＊ ＊ ＊ screw	＊ ＊ ＊ ＊ ＊ ＊ ＊ ＊ ＊ ＊ 止ネジ	2	
11	201080	＊ ＊ ＊ ＊ ＊ ＊ ＊ ＊ ＊ ＊ shaft	＊ ＊ ＊ ＊ ＊ ＊ ＊ ＊ ＊ ＊ 小ルーバー台軸	1	
12	201081	＊ ＊ ＊ ＊ ＊ ＊ ＊ ＊ ＊ ＊ flanged bushing	＊ ＊ ＊ ＊ ＊ ＊ ＊ ＊ ＊ ＊ ブッシュ (前)	1	
13	1457	＊ ＊ ＊ ＊ ＊ ＊ ＊ ＊ ＊ ＊ ＊ ＊ screw	＊ ＊ ＊ ＊ ＊ ＊ ＊ ＊ ＊ ＊ ＊ ＊ 止ネジ	1	
14	201083	＊ ＊ ＊ ＊ ＊ ＊ ＊ ＊ ＊ ＊ bushing	＊ ＊ ＊ ＊ ＊ ＊ ＊ ＊ ＊ ＊ (後)	1	
15	1457	＊ ＊ ＊ ＊ ＊ ＊ ＊ ＊ ＊ ＊ ＊ ＊ screw	＊ ＊ ＊ ＊ ＊ ＊ ＊ ＊ ＊ ＊ ＊ ＊ 止ネジ	1	
16	201081A	＊ ＊ ＊ ＊ ＊ ＊ ＊ ＊ ＊ ＊ bar	＊ ＊ ＊ ＊ ＊ ＊ ＊ ＊ ＊ ＊ 小ルーバー台	1	
17	5271	＊ ＊ ＊ ＊ ＊ ＊ ＊ ＊ ＊ ＊ screw	＊ ＊ ＊ ＊ ＊ ＊ ＊ ＊ ＊ ＊ 抱締ネジ	1	
18	202861	＊ ＊ ＊ ＊ ＊ ＊ ＊ ＊ ＊ ＊ looper	＊ ＊ ＊ ＊ ＊ ＊ ＊ ＊ ＊ ＊ 小ルーバー	1	
19	5136	＊ ＊ ＊ ＊ ＊ ＊ ＊ ＊ ＊ ＊ screw	＊ ＊ ＊ ＊ ＊ ＊ ＊ ＊ ＊ ＊ 止ネジ	1	
20	201018A	＊ ＊ ＊ ＊ ＊ ＊ ＊ ＊ ＊ ＊ thread eyelet (upper)	＊ ＊ ＊ ＊ ＊ ＊ ＊ ＊ ＊ ＊ 上糸道	1	
21	202180	＊ ＊ ＊ ＊ ＊ ＊ ＊ ＊ ＊ ＊ ＊ ＊ tension, complete with 201035A, 202278, 201086, 201039, 201182x2 & 5082	＊ ＊ ＊ ＊ ＊ ＊ ＊ ＊ ＊ ＊ 小ルーバー糸調子(組) ＊ ＊ ＊ ＊ ＊ ＊ ＊ ＊ ＊ ＊ 201035A, 202278, 201086, 201039, 201482x2, 5082との組	1	
22	201035A	＊ ＊ ＊ ＊ ＊ ＊ ＊ ＊ ＊ ＊ ＊ ＊ thread tension regulating thumb nut	＊ ＊ ＊ ＊ ＊ ＊ ＊ ＊ ＊ ＊ ナット	1	
23	202278	＊ ＊ ＊ ＊ ＊ ＊ ＊ ＊ ＊ ＊ ＊ ＊ spring bushing	＊ ＊ ＊ ＊ ＊ ＊ ＊ ＊ ＊ ＊ 棒ナット止パイプ	1	
24	201086	＊ ＊ ＊ ＊ ＊ ＊ ＊ ＊ ＊ ＊ ＊ ＊ spring	＊ ＊ ＊ ＊ ＊ ＊ ＊ ＊ ＊ ＊ バネ (中)	1	
25	201039	＊ ＊ ＊ ＊ ＊ ＊ ＊ ＊ ＊ ＊ ＊ ＊ cap	＊ ＊ ＊ ＊ ＊ ＊ ＊ ＊ ＊ ＊ 受皿	1	
26	201182	＊ ＊ ＊ ＊ ＊ ＊ ＊ ＊ ＊ ＊ ＊ ＊ disc	＊ ＊ ＊ ＊ ＊ ＊ ＊ ＊ ＊ ＊ 皿	2	
27	5082	＊ ＊ ＊ ＊ ＊ ＊ ＊ ＊ ＊ ＊ ＊ ＊ screw stud	＊ ＊ ＊ ＊ ＊ ＊ ＊ ＊ ＊ ＊ 棒	1	
28	202849	＊ ＊ ＊ ＊ ＊ ＊ ＊ ＊ ＊ ＊ ＊ ＊ guide	＊ ＊ ＊ ＊ ＊ ＊ ＊ ＊ ＊ ＊ 台	1	
29	201018A	＊ ＊ ＊ ＊ ＊ ＊ ＊ ＊ ＊ ＊ ＊ ＊ eyelet (lower)	＊ ＊ ＊ ＊ ＊ ＊ ＊ ＊ ＊ ＊ 前糸道	1	
30	1459	＊ ＊ ＊ ＊ ＊ ＊ ＊ ＊ ＊ ＊ ＊ ＊ screw	＊ ＊ ＊ ＊ ＊ ＊ ＊ ＊ ＊ ＊ 止ネジ	1	
31	201089	＊ ＊ ＊ ＊ ＊ ＊ ＊ ＊ ＊ ＊ ＊ ＊ guide (right)	＊ ＊ ＊ ＊ ＊ ＊ ＊ ＊ ＊ ＊ 小ルーバー糸道	1	
32	2921	＊ ＊ ＊ ＊ ＊ ＊ ＊ ＊ ＊ ＊ ＊ ＊ screw	＊ ＊ ＊ ＊ ＊ ＊ ＊ ＊ ＊ ＊ 止ネジ	1	
33	202875	＊ ＊ ＊ ＊ ＊ ＊ ＊ ＊ ＊ ＊ ＊ ＊ ＊ ＊ washer	＊ ＊ ＊ ＊ ＊ ＊ ＊ ＊ ＊ ＊ ＊ ＊ 座金	1	
34	202860	＊ ＊ ＊ ＊ ＊ ＊ ＊ ＊ ＊ ＊ ＊ ＊ guide (left)	＊ ＊ ＊ ＊ ＊ ＊ ＊ ＊ ＊ ＊ 小ルーバー補助糸道	1	
35	2921	＊ ＊ ＊ ＊ ＊ ＊ ＊ ＊ ＊ ＊ ＊ ＊ screw	＊ ＊ ＊ ＊ ＊ ＊ ＊ ＊ ＊ ＊ 止ネジ	1	
36	202875	＊ ＊ ＊ ＊ ＊ ＊ ＊ ＊ ＊ ＊ ＊ ＊ ＊ ＊ washer	＊ ＊ ＊ ＊ ＊ ＊ ＊ ＊ ＊ ＊ ＊ ＊ 座金	1	
37	202830A	＊ ＊ ＊ ＊ ＊ ＊ ＊ ＊ ＊ ＊ ＊ ＊ take-up	＊ ＊ ＊ ＊ ＊ ＊ ＊ ＊ ＊ ＊ 糸捌キ	1	
38	2921	＊ ＊ ＊ ＊ ＊ ＊ ＊ ＊ ＊ ＊ ＊ ＊ screw	＊ ＊ ＊ ＊ ＊ ＊ ＊ ＊ ＊ ＊ 止ネジ	1	
39	201088	＊ ＊ ＊ ＊ ＊ ＊ ＊ ＊ ＊ ＊ ＊ ＊ bracket	＊ ＊ ＊ ＊ ＊ ＊ ＊ ＊ ＊ ＊ 取付台	1	
40	1202	＊ ＊ ＊ ＊ ＊ ＊ ＊ ＊ ＊ ＊ ＊ ＊ screw	＊ ＊ ＊ ＊ ＊ ＊ ＊ ＊ ＊ ＊ 止ネジ	1	
41	201001	＊ ＊ ＊ ＊ ＊ ＊ ＊ ＊ ＊ ＊ ＊ ＊ tube (long)	＊ ＊ ＊ ＊ ＊ ＊ ＊ ＊ ＊ ＊ 糸道パイプ (長)	1	
42	1802	＊ ＊ ＊ ＊ ＊ ＊ ＊ ＊ ＊ ＊ ＊ ＊ screw	＊ ＊ ＊ ＊ ＊ ＊ ＊ ＊ ＊ ＊ 止ネジ	1	
43	201092A	＊ ＊ ＊ ＊ ＊ ＊ ＊ ＊ ＊ ＊ ＊ ＊ bracket	＊ ＊ ＊ ＊ ＊ ＊ ＊ ＊ ＊ ＊ 取付台	1	
44	1175-2	＊ ＊ ＊ ＊ ＊ ＊ ＊ ＊ ＊ ＊ ＊ ＊ screw	＊ ＊ ＊ ＊ ＊ ＊ ＊ ＊ ＊ ＊ 止ネジ	1	

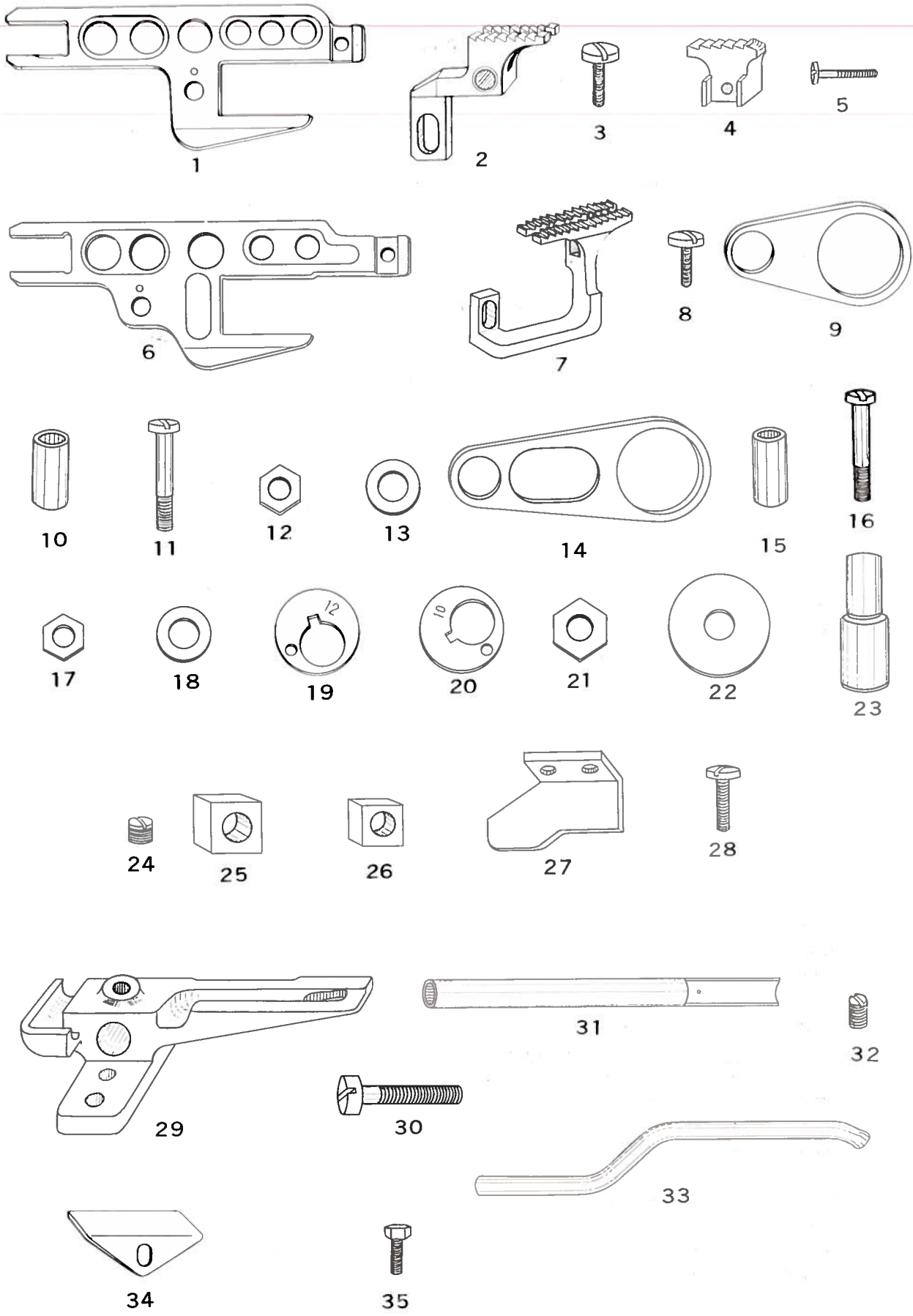

# MAIN & DIFFERENTIAL FEEDING MECHANISM

## 送　　り　　機　　構

Ref. No. 参照番号	Parts No. 部品番号	Name	名　　称	Qt. 数量	Remarks 備　考
1	201093A	Main feed bar	主送り台	1	
2	*201091B	＊ ＊ ＊ dog	主送り歯	1	DCR-801, 802, 805, 881, 809(2mm), 885, & 889(2mm) only 用
3	1202	＊ ＊ ＊ screw	＊ 止ネジ	1	
4	*202631	Auxiliary feed dog	補助送り歯	1	
5	5086	＊ ＊ ＊ screw	＊ 止ネジ	1	
6	201096A	Differential feed bar	差動送り台	1	
7	*201097B	＊ ＊ ＊ dog	差動送り歯	1	DCR-801, 802 & 881 only 用
8	1202	＊ ＊ ＊ screw	＊ 止ネジ	1	
9	201098	Main feed connecting link	主送り連結桿	1	
10	*201099	＊ ＊ ＊ ＊ bushing	＊ ブッシュ	1	DCR-801, 802, 805, 809, 810, 881, 885 & 889 only 用
11	201100	＊ ＊ ＊ ＊ ＊ screw	＊ ＊ ＊ 止ネジ	1	
12	3044	＊ ＊ ＊ ＊ ＊ ＊ nut	＊ ＊ ＊ ＊ ナット	1	
13	200098	＊ ＊ ＊ ＊ ＊ ＊ ＊ washer	＊ ＊ ＊ ＊ ＊ 座金	1	
14	201101	Differential feed connecting link	差動連結桿	1	
15	201099	＊ ＊ ＊ ＊ ＊ bushing	＊ ブッシュ	1	
16	201100	＊ ＊ ＊ ＊ ＊ ＊ screw	＊ ＊ ＊ 止ネジ	1	
17	3044	＊ ＊ ＊ ＊ ＊ ＊ ＊ nut	＊ ＊ ＊ ＊ ＊ ナット	1	
18	200098	＊ ＊ ＊ ＊ ＊ ＊ ＊ ＊ washer	＊ ＊ ＊ ＊ ＊ ＊ 座金	1	
19	*201103-12	Main feed eccentric #12	主送りエキセン #12	1	DCR-801, 802, 805, 809, 881, 885 & 889 only 用
20	*201103-10	Differential feed eccentric #10	差動送りエキセン #10	1	
21	3018	Feed eccentric nut	送りエキセン止ナット	1	
22	201104	＊ ＊ ＊ ＊ washer	＊ ＊ ＊ 座金	1	
23	202200	Feed bar tilting adjusting pin	送り台ピン	1	
24	2022	＊ ＊ ＊ ＊ ＊ ＊ screw	＊ 止ネジ	1	
25	201106	＊ lift block	送り上下角玉	1	
26	201107	＊ bar guide block	送り台案内角玉	2	
27	201109	Differential feed bar guide	送り台案内 (右)	1	
28	1175-3	＊ ＊ ＊ ＊ ＊ ＊ screw	＊ ＊ ＊ ＊ 止ネジ	2	
29	202201A	Main feed bar guide	＊ ＊ ＊ (左)	1	
30	5095	＊ ＊ ＊ ＊ ＊ ＊ screw	＊ ＊ ＊ ＊ 止ネジ	2	
31	201110	Oil tube for oil wick, for 201093A & 201096A	送り台給油パイプ	1	
32	1135	＊ ＊ ＊ screw	＊ 止ネジ	1	
33	202202	＊ ＊ ＊ for oil wick, for 201103	送りエキセン給油パイプ	1	
34	202203	＊ ＊ ＊ retainer	＊ ＊ ＊ 押工金	1	
35	1196	＊ ＊ ＊ ＊ screw	＊ ＊ ＊ ＊ 止ネジ	1	

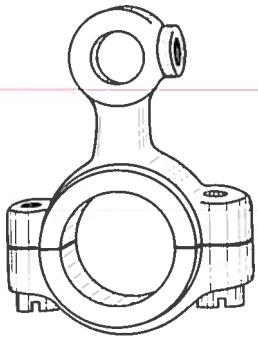

1



2

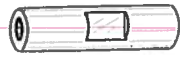

3



4



5

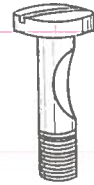

6



7

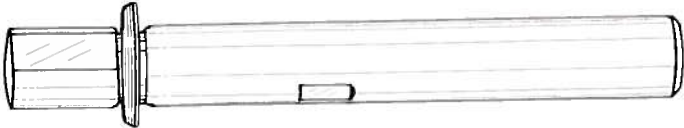

8



9



10

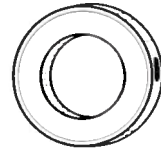

11



12

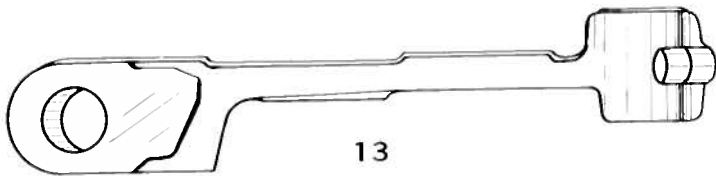

13



14



15

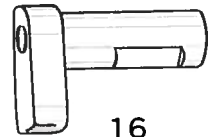

16



17



18



19

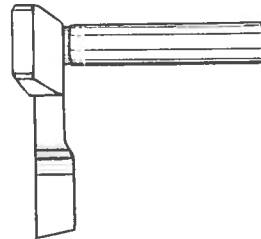

20



21



22



23



24



25

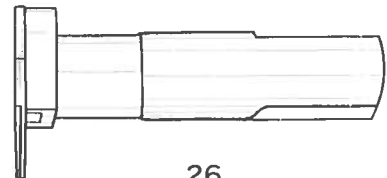

26



27



28



29



30

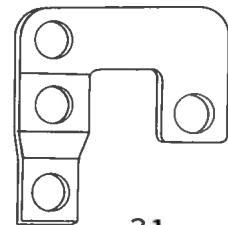

31



32



33



34



35

UPPER & LOWER KNIFE MECHANISM  
上・下メス機構

Ref. No. 参照番号	Parts No. 部品番号	Name	名称	Qty. 数量	Remarks 備考
1	201380A	Upper knife connecting rod	上メスロッド	1	
2	5002	＊ ＊ ＊ ＊ screw	＊ ＊ 蓋ネジ	2	
3	202711A	＊ ＊ ＊ ＊ hinge pin	＊ ＊ ピン	1	
4	1457	＊ ＊ ＊ ＊ ＊ ＊ screw	＊ ＊ ＊ 止ネジ	1	
5	201360	＊ ＊ lever shaft crank	上メスクランク	1	
6	5087	＊ ＊ ＊ ＊ ＊ ＊ screw	＊ ＊ 抱締ネジ	1	
7	5181	＊ ＊ ＊ ＊ ＊ ＊ nut	＊ ＊ ＊ ナット	1	
8	201114	＊ ＊ ＊ shaft	上メス台軸	1	
9	201115A	＊ ＊ ＊ ＊ bushing	＊ ＊ ブッシュ	2	
10	1457-1	＊ ＊ ＊ ＊ ＊ ＊ screw	＊ ＊ ＊ 止ネジ	2	
11	201117	＊ ＊ ＊ ＊ thrust collar	＊ ＊ スラストカラー	1	
12	5084	＊ ＊ ＊ ＊ ＊ ＊ screw	＊ ＊ ＊ 止ネジ	2	
13	202635	＊ ＊ lever	上メス台	1	
14	201076	＊ ＊ ＊ ＊ cotter screw	＊ ＊ コッター	1	
15	5181	＊ ＊ ＊ ＊ ＊ ＊ nut	＊ ＊ ＊ ナット	1	
16	202636	＊ ＊ ＊ guide	＊ ＊ 案内	1	
17	2022	＊ ＊ ＊ ＊ screw	＊ ＊ ＊ 止ネジ	1	
18	*201121A	＊ knife (tungsten tipped)	上メス	1	DCR-801, 802, 803, 805, 809, 881, 885, & 889, only 共用
19	5088	＊ ＊ screw	＊ ＊ 止ネジ	1	
20	*202637A	＊ ＊ holder	＊ ＊ 抱キ	1	
21	1175-2	＊ ＊ ＊ ＊ screw	＊ ＊ ＊ 抱締ネジ	1	
22	202638A	＊ ＊ ＊ guide	＊ ＊ ＊ 案内	1	
23	1222	＊ ＊ ＊ ＊ screw	＊ ＊ ＊ ＊ 止ネジ	1	
24	201125	＊ ＊ ＊ ＊ pin	＊ ＊ ＊ ＊ ピン	1	DCR-801, 802, 803, 805, 805, 809, 881, 885 & 889 only
25	*202295	Lower knife	ドメス	1	
26	*201128C	＊ ＊ holder	＊ ＊ 台	1	DCR-801, 802, 803, 805, 809 & 810 only 共用
27	4009-1	＊ ＊ ＊ ＊ screw	＊ ＊ ＊ 止ネジ	1	
28	201129	＊ ＊ ＊ ＊ spring	＊ ＊ ＊ 押シバネ	1	
29	201130A	＊ ＊ ＊ ＊ ＊ ＊ retainer	＊ ＊ ＊ ＊ 押エ	1	
30	1175-3	＊ ＊ ＊ ＊ ＊ ＊ screw	＊ ＊ ＊ ＊ ＊ 止ネジ	2	
31	201131A	＊ ＊ ＊ ＊ guide	＊ ＊ ＊ 案内板	1	
32	1175-3	＊ ＊ ＊ ＊ ＊ ＊ screw	＊ ＊ ＊ ＊ 止ネジ	2	
33	201132B	＊ ＊ clamp stud	＊ ＊ 止ピン	1	
34	5260	＊ ＊ ＊ ＊ ＊ ＊ thumb nut	＊ ＊ ＊ ＊ ナット	1	
35	201134	＊ ＊ ＊ ＊ ＊ ＊ ＊ washer	＊ ＊ ＊ ＊ ＊ 座金	1	



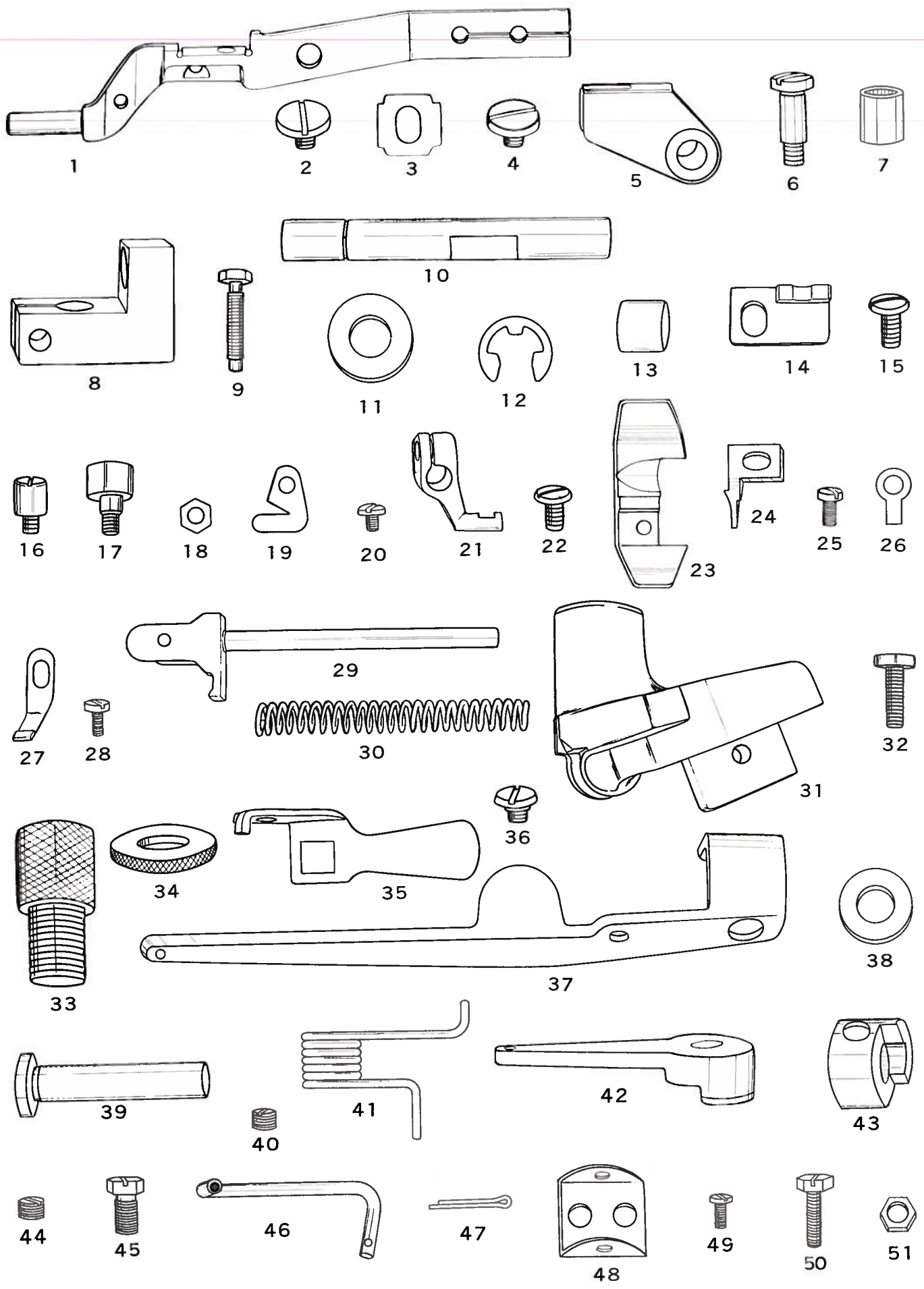

**PRESSER FOOT & LIFTING MECHANISM**

**押 工 機 構**

Ref. No.	Parts No.	Name	名 称	Qty.	Remarks
参照番号	部品番号			数量	備 考
1	202502B	Presser arm	押エ台	1	
2	5214	* * screw	* 止ネジ	1	
3	202503	* * regulator	押エ前後調節器	1	
4	5214	* * * screw	* * 止ネジ	1	
5	202505	* * hinge	押エ台ヒンジ	1	
6	5164	* * * stud screw	* * 蝶番ネジ	1	
7	201141	* * * * bushing	* * * ブッシュ	1	
8	202575	* * * bracket	* * 取付台	1	
9	5266	* * * * screw	* * * 締付ネジ	1	
10	202574	* * * shaft	* 軸	1	
11	202576	* * * thrust collar	* * スラストカラー	1	
12	202577	* * * retaining ring	* * 止め輪	1	
13	202589	* * * bushing	* * ブッシュ	3	
14	202578	* * guide, for 202507	* 案内片	1	
15	5117	* * guide screw	* * 止ネジ	1	
16	5257	* * stopper	押エストッパー	1	
17	5258	* * regulating screw (eccentric)	* 調節器	1	
18	5137	* * * * nut	* * ナット	1	
19	202451	Chain cutter knife	チェーンカッター	1	
20	2921	* * * screw	* 止ネジ	1	
21	202504A	Presser foot holder	押エ取付台	1	
22	4009-1	* * * clamp screw	* 抱締ネジ	1	
23	*201152D	* foot	押エ	1	} DCR-801 & 881 only 用
24	*201155C	* * chaining-off finger	* 爪	1	
25	5089	* * * * screw	* * 止ネジ	1	
26	201156	* * hinge spring	* 取付板	1	
27	202512A	* * regulator	* 固定金	1	
28	1229	* * * screw	* * 止ネジ	1	
29	202507	* spring plunger, with 202508 & 202509	* 棒(組) 202508, 202509との組	1	
30	201148A	* spring	* バネ	1	
31	202518	* * * & plunger housing	* 棒案内	1	
32	2903	* * * * * screw	* * 止ネジ	2	
33	202510	Pressure regulating thumb screw	* キャップ	1	
34	202871	* * * * lock nut	* * ロックナット	1	
35	202511	Hand lift lever	* 手揚	1	
36	5256	* * * screw	* 段ネジ	1	
37	201160B	Foot lift lever	足揚(大)	1	
38	202868	* * * hinge pin washer	* * 座金	1	
39	201161	* * * * *	* * ピン	1	
40	2022	* * * * * screw	* * 止ネジ	1	
41	201162A	* * * spring	* バネ	1	
42	201163	* * intermediate lever	* (小)	1	
43	201164A	* * * * collar	* カラー	1	
44	2022	* * * * * screw (small)	* * 止ネジ(頭ナシ)	1	
45	2022-1	* * * * * screw (large)	* * (頭ソキ)	1	
46	201165	* * lever connecting link	* 連結ピン	1	
47	201166	* * * * * cotter pin	* 割ピン	2	
48	201167	* * * bracket	* 調節台(コ型)	1	
49	5142	* * * * screw	* * * 止ネジ	2	
50	5097	* * * regulating screw	* 調節ネジ	2	
51	3044	* * * * * nut	* * ナット	2	

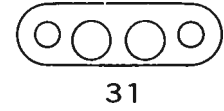
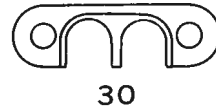
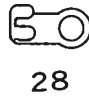
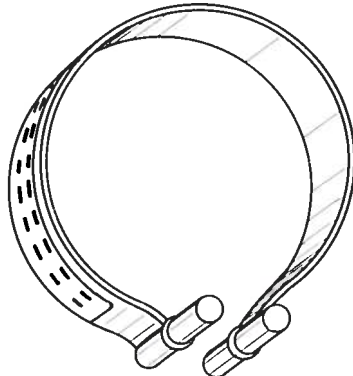
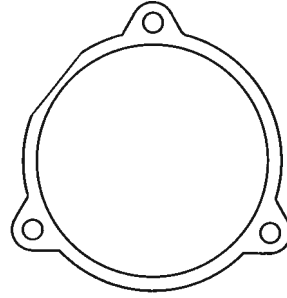
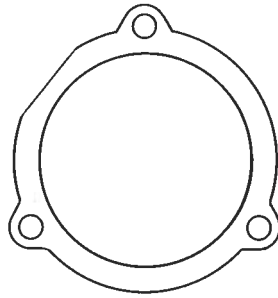
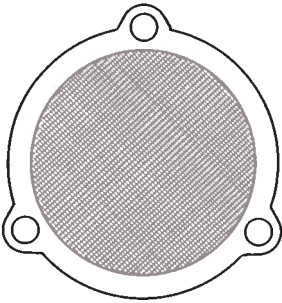
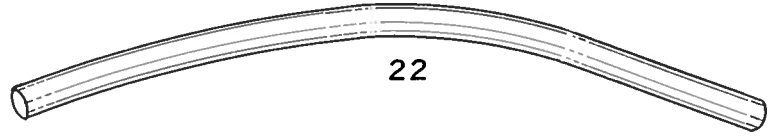
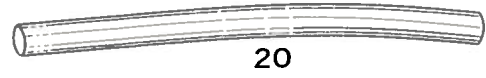
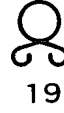
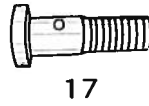
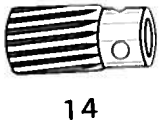
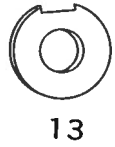
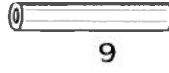
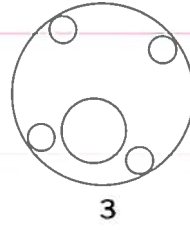
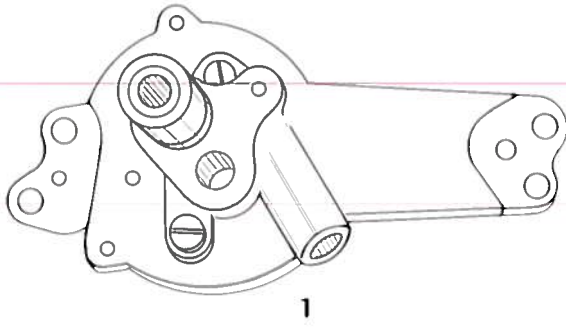

PUMP & LUBRICATING MECHANISM (1)

ポンプ・給油機構 (1)

Ref. No. 参照番号	Parts No. 部品番号	Name	名称	Qt. 数量	Remarks 備考
1	201288A	Casing, complete with	ケーシング (組)	1	{201548×2, 201289A, 201290A, 2213-1×2 201291, 201292との組
2	2213-1	* screw	* 止ネジ	4	
3	201293A	* cover plate	側板	1	
4	5117	* * * screw	* 止ネジ	4	
5	201294	Pump gear for 201296	ポンプギヤー (A)	1	
6	201295	* * * 201297	* (B)	1	
7	201296	* * shaft (long)	ギヤーシャフト (A)	1	
8	201009	* * * * key	* * キー	1	
9	201297	* * shaft (short)	* (B)	1	
10	1458	* * * * screw	* * 止ネジ	2	
11	201298	Worm	ウオーム	1	
12	5060	* screw	* 止ネジ	2	
13	202722A	* gear thrust washer	* ギヤースラストワッシャー	1	
14	201299	* wheel	* ホイール	1	
15	5060	* * screw	* * 止ネジ	2	
16	201300	Oil distributing tube joint	給油パイプ 継手雌	2	
17	201301	* * * * screw	* 継手雄	2	
18	201302	* * * * * washer	* 継手パッキン	4	
19	201303	* * * clamp	* 抱締バネ	4	
20	201319	* * tube (short)	ビニールパイプ (A)	1	
21	201304	* * * spring	* * 抱バネ	1	
22	201320-1	* * tube (long)	* (B)	1	
23	201338	* screen filter, complete with 201339 & 201340	フィルター (組) 201339, 201340との組	1	
24	201311	* * * gasket	* 内枠パッキン	1	
25	201341	* * * frame	* 取付板	1	
26	1175-2	* * * * screw	* 止ネジ	3	
27	201342B	* radiator, complete with 201484, 201343Bx3 & 201344Bx2	冷却器 (組) {201484, 201343B×3 201344B×2との組	1	
28	201345A	* * clamp	* 止金	1	
29	3001	* * * screw	* * 止ネジ	1	
30	201315	* * retaining plate	* 継手止板	1	
31	201316	* * * * gasket	* * パッキン	1	
32	5152	* * * * screw	* * 止ネジ	2	
33	200149	* * * * * washer	* * * パッキン	2	

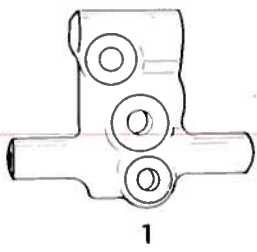

1



2



3



4



5



6



7

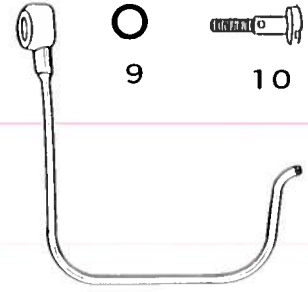

8



9

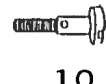

10



11



12



13



14



15

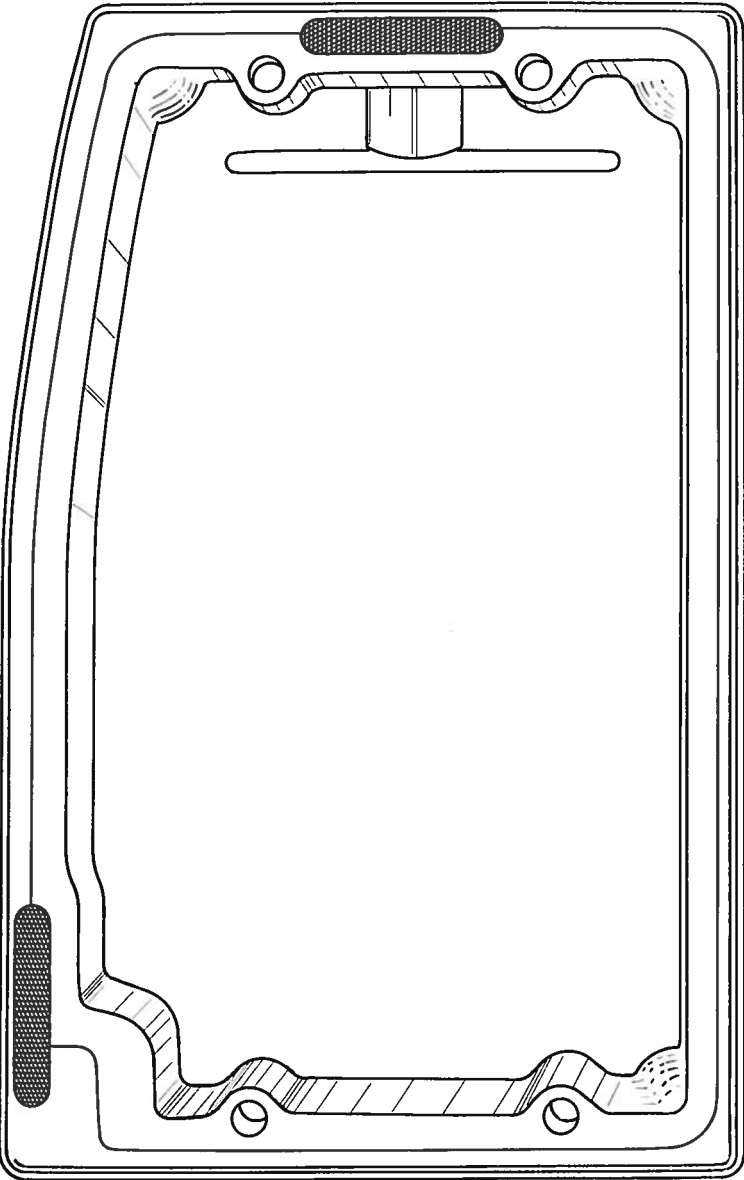

16

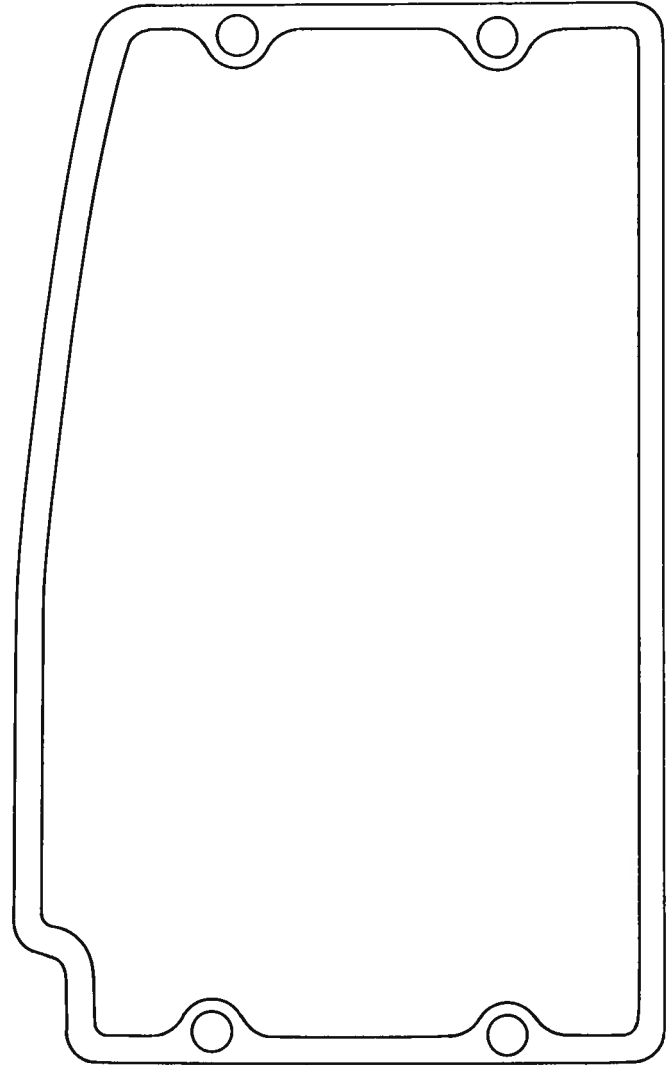

17



18



19



20



21



22

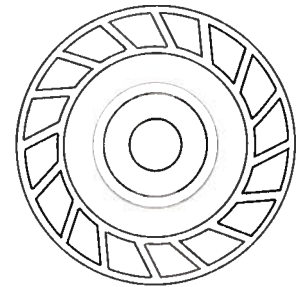

23



24



25



26

PUMP & LUBRICATING MECHANISM (2)

ポンプ・給油機構 (2)

Ref. No. 参照番号	Parts No. 部品番号	Name	名称	Qt. 数量	Remarks 備考
1	201321	Oil distributor	油配分器	1	
2	5095	* * screw	* 止ネジ	2	
3	5261	* * cap screw	* 蓋ネジ	1	
4	201322	* splash pipe	噴油口金 (A)	1	
5	201759	* * * washer	* * パッキン	1	
6	201323	* distributor pipe screw (small)	* (B)	1	
7	201324	* * * screw (large)	* (C)	1	
8	201327	* distributing tube for 201298 & 201299	ウォームギヤー給油管 (組) 201757との組	1	
9	201759	* * * washer	* * 継手パッキン	2	
10	201758	* * * joint screw	* * * (雄)	1	
11	202208	* * * clamp	* * 止め金	1	
12	5117	* * * * screw	* * * 止ネジ	1	
13	201328	Oil splash sight window	オイル窓	1	
14	201329	* * * * gasket	* パッキン	1	
15	5142	* * * * screw	* 止ネジ	3	
16	201331B	* reservoir (machine base)	オイルパン	1	
17	201335	* * gasket	* パッキン	1	
18	201487	* strainer for 2013331B	* 油濾金板	1	
19	5138A	* drain plug screw	* 排油穴蓋ネジ	1	
20	202287	* * * * "O" ring	* * "O" リング	1	
21	5150	* reservoir bolt	* 取付ホルト	1	
22	201320	* * * washer	* * パッキン	1	
23	201325B	* radiator fan	ファン	1	
24	5149	* * * position screw	* 止ネジ (先付)	1	
25	1458	* * * screw	* * (先ナシ)	1	
26	5198	* filler plug screw	注油口蓋ネジ	1	

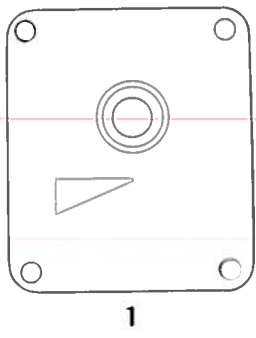

1

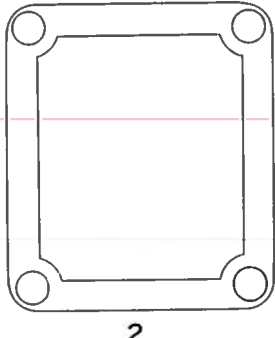

2



3

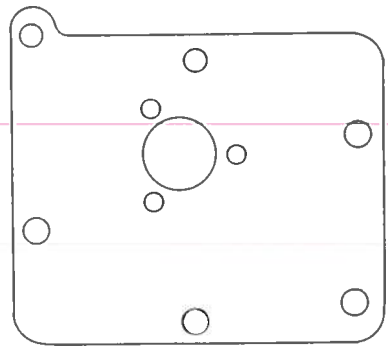

4

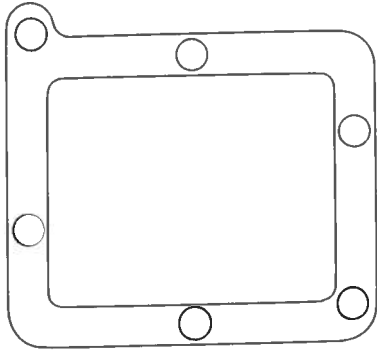

5



6

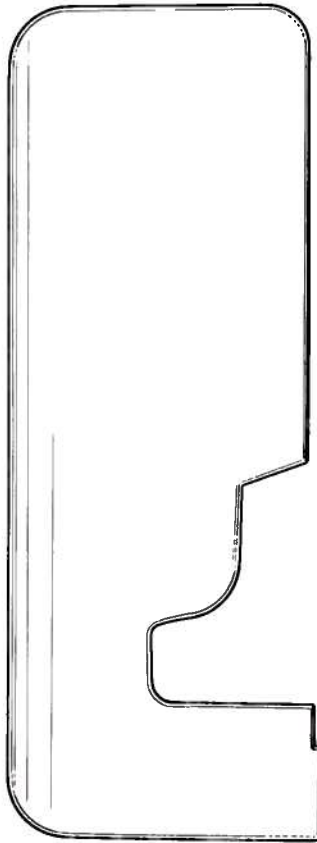

7

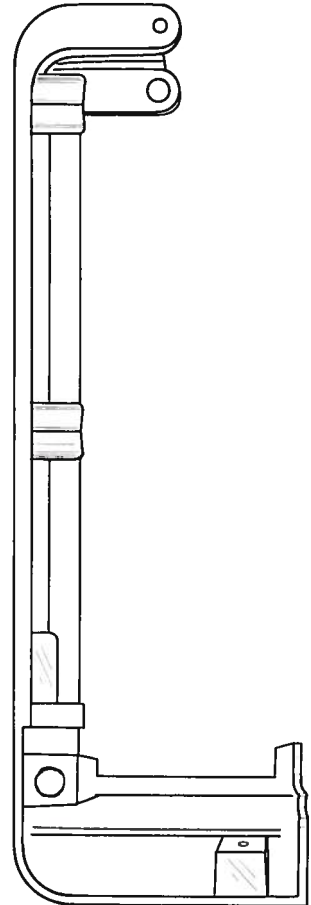

8



9



10



11



12

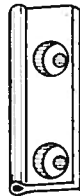

13



14



15

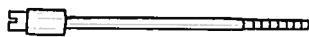

16



17



18



19



20

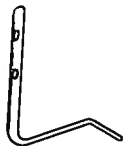

21



22



23



24



25



26



27

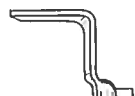

29



30



31



32

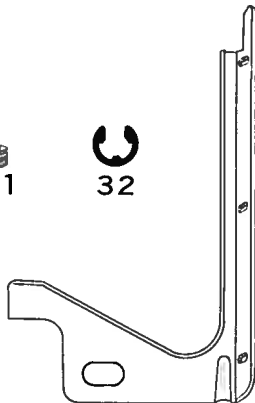

33



34

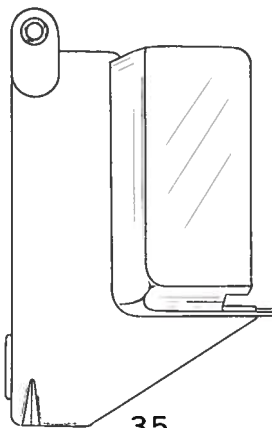

35



36



37

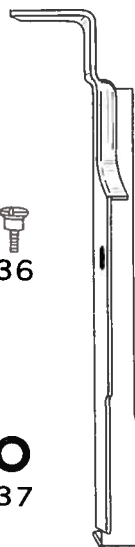

28



CLOTH PLATE & MISCELLANEOUS COVERS

カバ ー ・ 外 装 関 係 (1)

Ref. No.	Parts No.	Name	名 称	Qt.	Remarks
参照番号	部品番号			数量	備 考
1	202834A	Machine bed cover plate	ベッド上板	1	
2	201177A	* * * * gasket	* パッキン	1	
3	5118	* * * * screw	* 止ネジ	1	
4	201178A	* arm cover plate	アーム上板	1	
5	201179A	* * * * gasket	* パッキン	1	
6	5117	* * * * screw	* 止ネジ	3	
7	*201180B *201181B	Cloth plate, complete with plate, with 201182A	大カバー (組) 上: 201182A との組	1 1	} DCR-801, 802, 803, 805, 809 & 810 only 用
8	201183A	* plate extension	* 下	1	
9	201184	* * * * bracket	* 上・下 取付台	4	
10	1216	* * * * screw (upper)	* * 上止ネジ	4	
11	1202	* * * * screw (lower)	* * 下止ネジ	4	
12	201185	* * * * * washer	* * * 座金	4	
13	200159	* * hinge	* ヒンジ	1	
14	2213-1	* * * * screw	* * 止ネジ	2	
15	200183	* * * * thrust collar	* * スラストカラー	1	
16	201221	* * * * pin	* * ピン	1	
17	5099	* * * * nut	* * ナット	1	
18	200821	* * * * * washer	* * * 座金	1	
19	202865	* * * * stop	* * 廻り止め	1	
20	5136	* * * * * screw	* * * 止ネジ	1	
21	201186	* * lock spring	* 止バネ	1	
22	1216	* * * * * screw	* * 止ネジ	2	
23	200162	* * * * * washer	* * * 座金	1	
24	200163	* * * * * catch	* * 掛 金	1	
25	1435	* * * * * screw	* * * 止ネジ	1	
26	1435	* * stop screw	* ストップネジ	1	
27	3044	* * * * nut	* * ナット	1	
28	202513	* * fabric guard	衣除ケ	1	
29	1216	* * * * * screw	* 止ネジ	2	
30	202521	* * * * * pin	* 取付ピン	1	
31	1457	* * * * * screw	* * 止ネジ	1	
32	202522	* * * * * retaining ring	* * 止め輪	1	
33	201188	Machine bed oil shield	ベッド油除ケ	1	
34	1216	* * * * * screw	* 止ネジ	1	
35	201189A	Feed mechanism cover	送り台カバー	1	
36	5215A	* * * * * screw	* 取付ネジ	1	
37	201191	* * * * * washer	* * バネ座金	2	

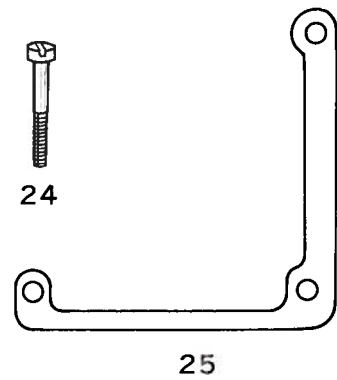
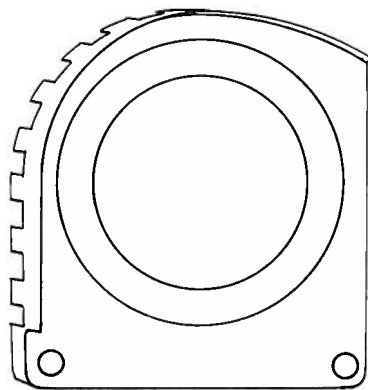
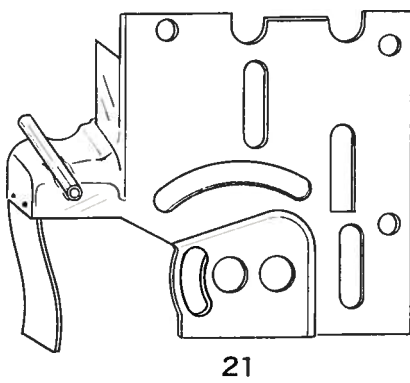
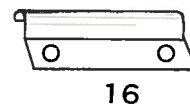
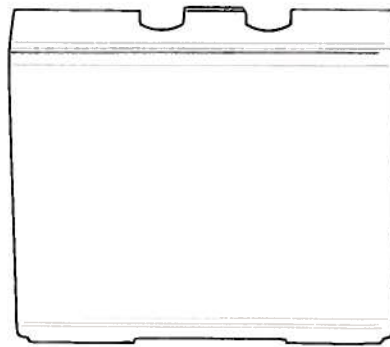
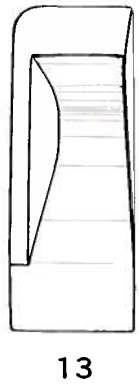
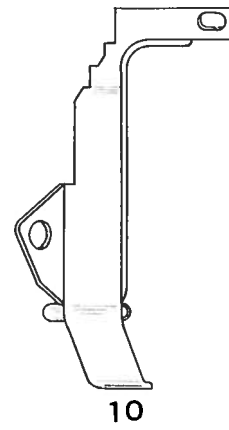
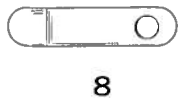
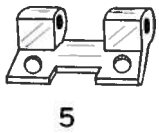
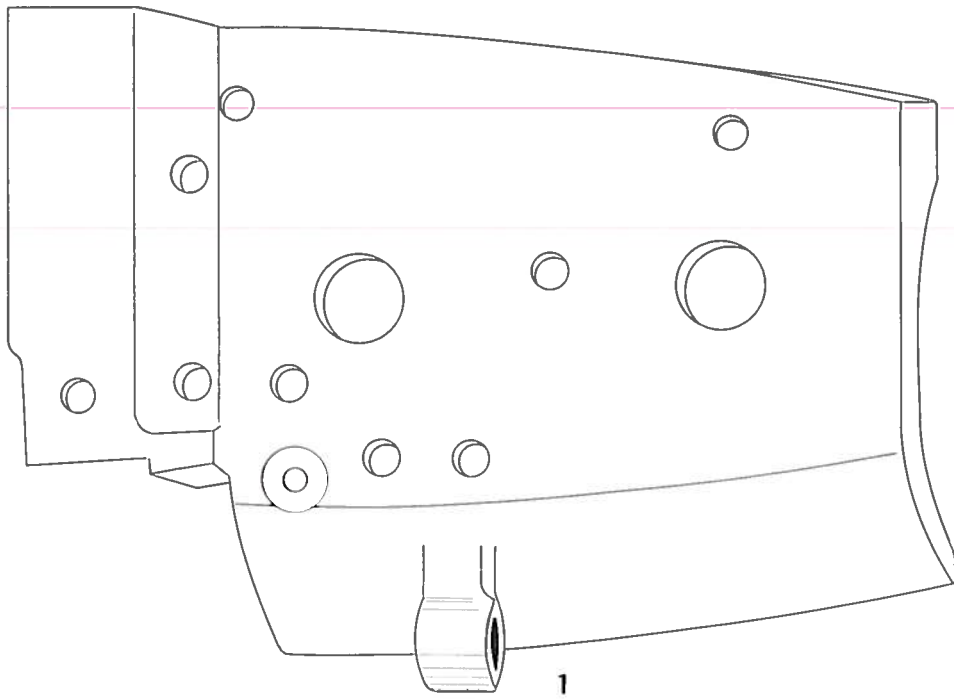

MAIN FRAME & MISCELLANEOUS COVERS

カバ - ・ 外 装 関 係 (2)

Ref. No. 参照番号	Parts No. 部品番号	Name	名 称	Qt. 数量	Remarks 備 考
1	202514	Machine top cover (right)	上カバー	1	
2	5094	* * * screw (long)	* 止ネジ (中)	2	
3	5095	* * * screw (short)	* * (短)	1	
4	*202867	* * cover (left) , with 202581	上メス台カバー 202581との組	1	DCR-801, 802, 803, 805, 809 & 810 only 用
5	202516	* * * hinge	* ヒンチ	1	
6	2918	* * * * screw	* * 止ネジ	2	
7	202579	* * * * pin	* * ピン	2	
8	202517	* * * lock spring	* 止バネ	1	
9	5117	* * * * * screw	* * 止ネジ	1	
10	202843	Chip guard (left), with 201090	前カバー (左) 201090との組	1	
	201090	* * * thread tube	小ルーバー糸道パイプ (短)	1	
11	1216	* * * screw (upper)	前カバー (左) 止ネジ (上)	1	
12	2905	* * * screw (lower)	* * * (下)	1	
13	202680	* * (right)	* (中)	1	
14	2921	* * * screw	* * 止ネジ	2	
15	201200	Front cover	* (右)	1	
16	201201	* * hinge	* * ヒンチ	1	
17	1216	* * * screw	* * * 止ネジ	2	
18	201202	* * * pin	* * * ピン	1	
19	201203	* * lock spring	* * 止バネ	1	
20	1216	* * * * screw	* * * 止ネジ	1	
21	202838	Looper thread plate, complete with { 202762, 202839, 201235 & 201236	大ルーバー右カバー(組) { 202762, 202839, 201235, 201236との組	1	
	202762	* * * oil shield	* 油除け	1	
	202839	* * tube	大ルーバー糸道パイプ	1	
	201235	* * plate oil shield rivet	大ルーバー右カバー 油除けリベット	1	
	201236	* * * * * washer	* * * 座金	1	
22	1216	* * * screw	* 止ネジ	3	
23	201318 A	Oil radiator cover	冷却器カバー	1	
24	5094	* * * screw	* 止ネジ	3	
25	202748	* * * gasket	* バッキン	1	



1



2



3



4

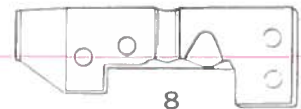

8

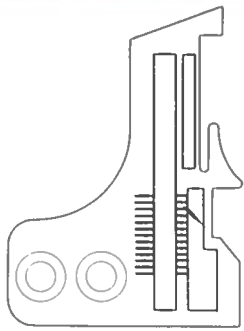

5

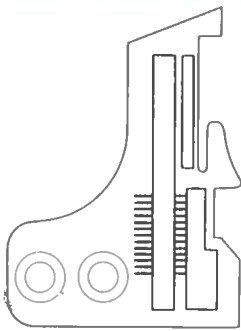

6

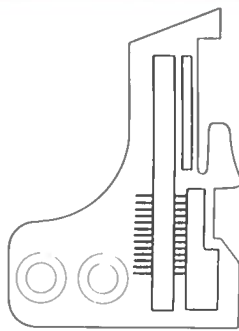

7



9



12

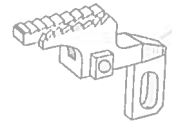

15



10



13



11

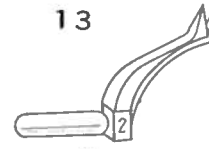

14



16

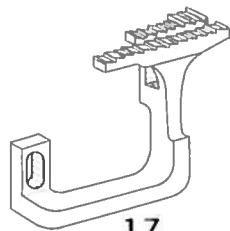

17



18

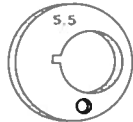

19



20



21

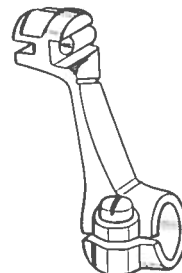

22



23



24



25

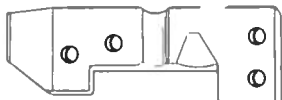

26



27



28



29



30



31

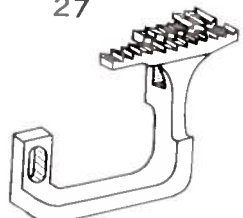

32



33

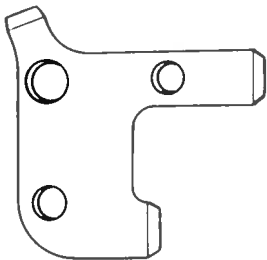

35



36

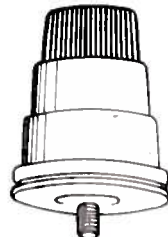

37



38

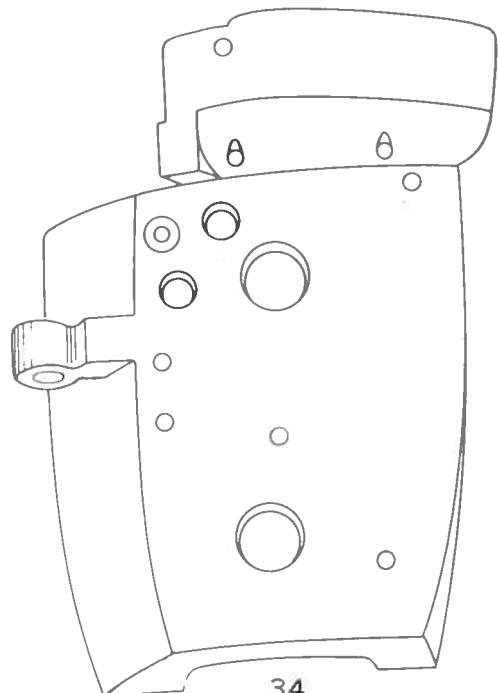

34

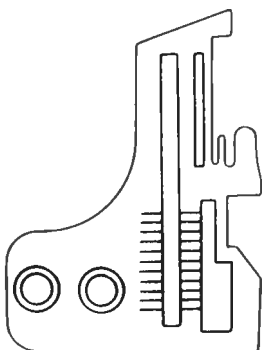

39

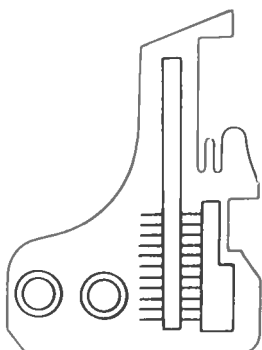

40

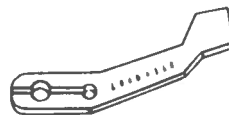

40

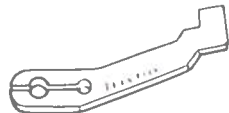

41

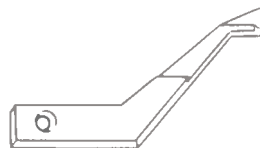

43

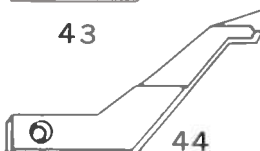

44



45

**PARTS FOR MODEL DCR-802 (Plain Overedging) ONLY**

**DCR-802型 専用部品**

Ref. No. 参照番号	Parts No. 部品番号	Name	名 称	Qt. 数量	Remarks (Also for) 備 考 (適用機種)
1	202802	Model plate	型式板	1	
2	201473	Presser foot	押エ	1	
3	201224B	＊ ＊ chaining-off finger	＊ 爪	1	DCR-803

**PARTS FOR MODEL DCR-803 (2-Thread Serging) ONLY**

**DCR-803型 (2本糸) 専用部品**

4	202803	Model plate	型式板	1	
5	202684	Needle plate (3mm seam width)	針 板 (縫巾 3.0mm)	1	
6	202685	＊ ＊ (4mm ＊ ＊)	＊ ( ＊ 4.0mm)	1	
7	202669	＊ ＊ (5mm ＊ ＊)	＊ ( ＊ 5.0mm)	1	
8	201230B	Presser foot	押 エ	1	DCR-805, 809 (2mm), 885 & 889 (2mm)
9	201224B	＊ ＊ chaining-off finger	＊ 爪	1	DCR-802
10	201265B	＊ ＊ fabric guard	補助押エ	1	DCR-805, 809, 885 & 889
11	1231	＊ ＊ ＊ ＊ screw	＊ 止ネジ	1	
12	201270A	＊ ＊ chain shield	押エ補助板	1	DCR-805, 809, 885 & 889
13	5030	＊ ＊ ＊ ＊ screw	＊ 止ネジ	1	
14	202842	Right looper (Spreader)	大ルーパー #2	1	
15	201153	Main feed dog	主送り歯	1	
16	202671	Auxiliary feed dog	補助送り歯	1	
17	202854	Differential feed dog	差動送り歯	1	
18	201154	Main feed connecting link bushing	主送り連結桿ブッシュ	1	
19	201103-5.5	Feed eccentric #5.5	送りエキセン #5.5	2	
20	UOx154	Needle #11	針 #11	1	

**PARTS FOR MODEL DCR-805 (2-Needle Machine) ONLY**

**DCR-805型 (2本針) 専用部品**

21	202804	Model plate	型式板	1	
22	202271	Needle driving arm	針 腕	1	DCR-809 (2mm), 810, 885 & 889 (2mm)
23	202273	＊ clamp	針押エ	1	DCR-809, 810, 885 & 889
24	201239A	＊ ＊ screw stud	＊ 止ネジ	1	DCR-809 (2mm), 810, 885 & 889 (2mm)
25	202274	＊ shim	シ ム	1	DCR-809 (2mm), 810 (0.8mm), 885 & 889 (2mm)
26	201230B	Presser foot	押 エ	1	DCR-803, 809 (2mm), 885 & 889 (2mm)
27	201396B	＊ ＊ chaining-off finger	＊ 爪	1	DCR-885
28	201265B	＊ ＊ fabric guard	補助押エ	1	DCR-803, 809, 885 & 889
29	1231	＊ ＊ ＊ ＊ screw	＊ 止ネジ	1	
30	201270A	＊ ＊ chain shield	押エ補助板	1	DCR-803, 809, 810, 885 & 889
31	5030	＊ ＊ ＊ ＊ screw	＊ 止ネジ	1	
32	202854	Differential feed dog	差動送り歯	1	DCR-803, 809, 885 & 889
33	201241	Needle thread eyelet, complete	針糸道 (組)	1	DCR-809, 810, 885 & 889
34	202520	Machine top cover (right)	上カバー	1	
35	201243A	Needle thread tension guide	針糸調子台	1	
36	1732	＊ ＊ ＊ ＊ screw	＊ 止ネジ	1	
37	202478	＊ ＊ tension, complete	針糸調子 (組)	2	DCR-809, 810, 885 & 889
38	3044	＊ ＊ tension screw stud nut	＊ 棒止ナット	2	
39	202674	Needle plate (1.5mm needle gauge)	針 板 (針巾 1.5mm)	1	DCR-885
40	202675	＊ ＊ (2.0mm ＊ ＊)	＊ ( ＊ 2.0mm)	1	DCR-809, 885 & 889
41	201285B	＊ guard (upper) (1.5mm needle gauge)	針受 (A) ( ＊ 1.5mm)	1	DCR-810
42	201250B	＊ ＊ ( ＊ ) (2.0mm ＊ ＊)	＊ ＊ ( ＊ 2.0mm)	1	DCR-809, 885 & 889
43	201286B	＊ ＊ (lower) (1.5mm ＊ ＊)	＊ (B) ( ＊ 1.5mm)	1	DCR-810
44	201251B	＊ ＊ ( ＊ ) (2.0mm ＊ ＊)	＊ ＊ ( ＊ 2.0mm)	1	DCR-809, 885 & 889
45	UNx154	Needle #11	針 #11	2	



1



2



3



4



5



6

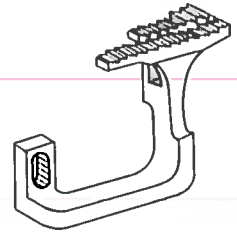

7

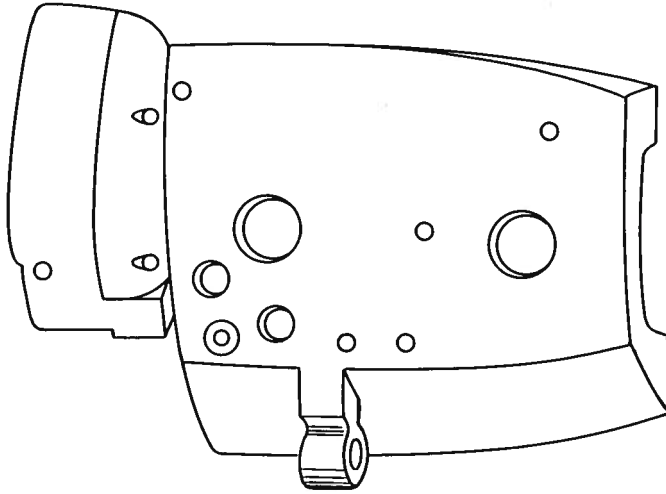

9



8

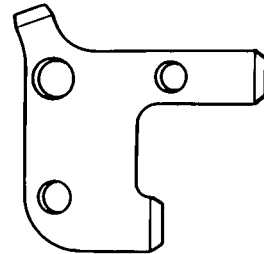

10

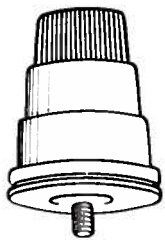

12



13

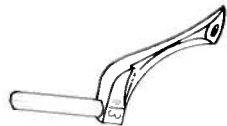

14

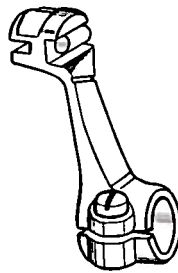

15

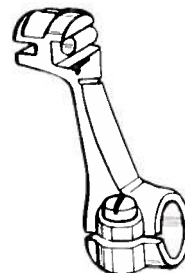

16



11



17



18



19



20

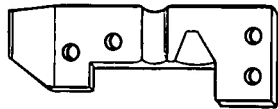

21

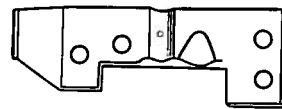

22

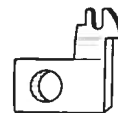

23

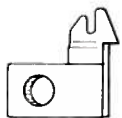

24

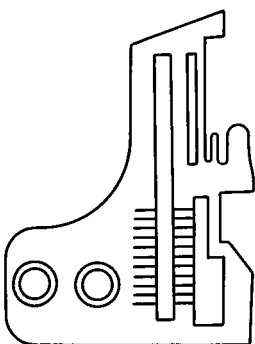

25

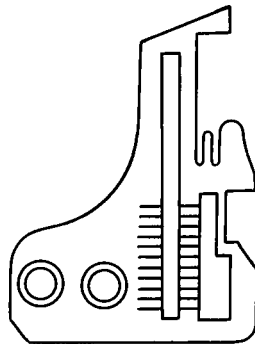

26

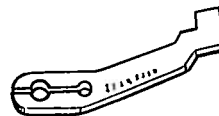

27

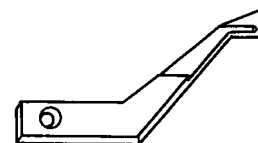

29

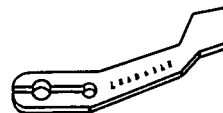

28

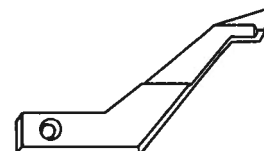

30

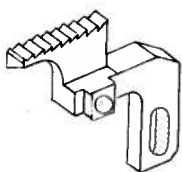

31



32



33

PARTS FOR MODEL DCR-809 (2-Needle Machine) ONLY

DCR-809型 (2本針) 専用部品

Ref. No.	Parts No.	Name	名称	Qty.	Remarks (Also for)
参照番号	部品番号			数量	備考 (適用機種)
1	202807	Model plate	型式板	1	
2	202273	Needle clamp	針押エ	1	DCR-805, 810, 885 & 889
3	201265B	Presser foot fabric guard	補助押エ	1	DCR-803, 805, 885 & 889
4	1231	" " " " screw	" 止ネジ	1	
5	201270 A	" " chain shield	押エ補助板	1	DCR-803, 805, 810, 885 & 889
6	5030	" " " " screw	" 止ネジ	1	
7	202851	Differential feed dog	差動送り歯	1	DCR-803, 805, 885 & 889
8	201241	Needle thread eyelet, complete	針糸道 (組)	1	DCR-805, 810, 885 & 889
9	202520	Machine top cover (right)	上カバー	1	
10	201243A	Needle thread tension guide	針糸調子台	1	
11	1732	" " " " screw	" 止ネジ	1	
12	202478	" " tension, complete	針糸調子 (組)	2	DCR-805, 810, 885 & 889
13	3041	" " tension screw stud nut	" 棒止ナット	2	
14	202872	Right looper	大ルーバー #3	1	
15	202271	Needle driving arm (2mm needle gauge)	針腕 (針巾 2.0mm)	1	DCR-805, 810, 885 & 889(2mm)
16	202272	" " " (3mm " " )	" ( " 3.0mm)	1	DCR-889 (3mm)
17	202274	" shim (2mm " " )	シム ( " 2.0mm)	1	DCR-805, 885 & 889(2mm)
18	202275	" " (3mm " " )	" ( " 3.0mm)	1	DCR-889 (3mm)
19	201239A	" clamp screw stud (2mm " " )	針押エ止ネジ ( " 2.0mm)	1	DCR-805, 810, 885 & 889(2mm)
20	201263A	" " " " (3mm " " )	" ( " 3.0mm)	1	DCR-889 (3mm)
21	201230B	Presser foot (2mm " " )	押エ ( " 2.0mm)	1	DCR-803, 805, 885 & 889(2mm)
22	201264A	" " (3mm " " )	" ( " 3.0mm)	1	DCR-889 (3mm)
23	201310A	" " chaining-off finger (2mm needle gauge)	" 爪 ( " 2.0mm)	1	DCR-889 (2mm)
24	201461A	" " " " (3mm " " )	" " ( " 3.0mm)	1	DCR-889 (3mm)
25	202675	Needle plate (2mm needle gauge)	針板 ( " 2.0mm)	1	DCR-805, 885 & 889(2mm)
26	202678	" " (3mm " " )	" ( " 3.0mm)	1	DCR-889 (3mm)
27	201250B	" guard (upper) (2mm " " )	針受 (A) ( " 2.0mm)	1	DCR-805, 885 & 889(2mm)
28	201267B	" " ( " ) (3mm " " )	" " ( " 3.0mm)	1	DCR-889 (3mm)
29	201251B	" " (lower) (2mm " " )	" (B) ( " 2.0mm)	1	DCR-805, 885 & 889(2mm)
30	201268B	" " ( " ) (3mm " " )	" " ( " 3.0mm)	1	DCR-889 (3mm)
31	201259	Main feed dog (3mm " " )	主送り歯 ( " 3.0mm 専用)	1	
32	202679	Auxiliary feed dog (3mm " " )	補助送り歯 ( " " )	1	
33	UNx151	Needle #14	針 #14	2	





1



2



3



4

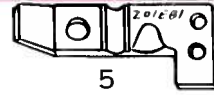

5



6



7



8

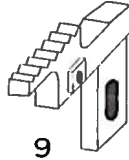

9



10



11

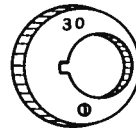

12

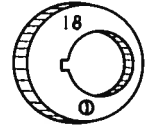

13

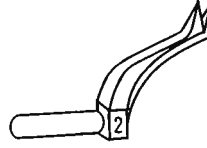

14

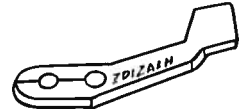

15

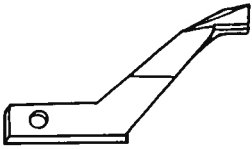

16

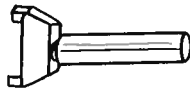

17



18



19

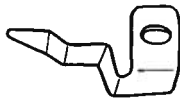

20



21

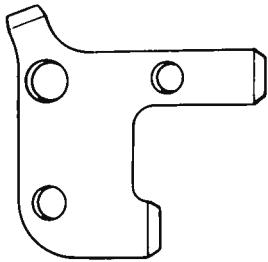

23



24

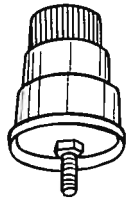

25



26

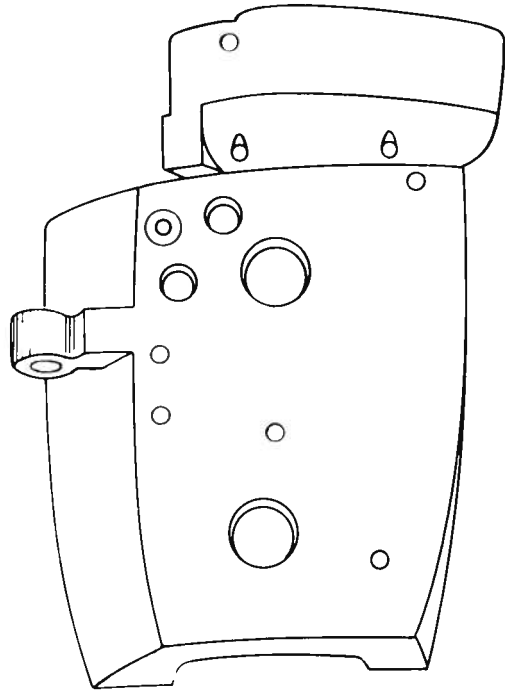

22



27



28



29



30



31



32

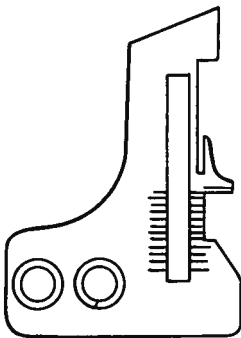

33

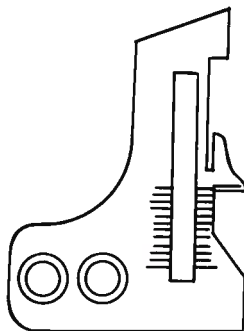

34



35



36

PARTS FOR MODEL DCR-810 (2-Needle Toe Closing Machine)

DCR-810型 (2本針) 専用部品

Ref.No. 参照番号	Parts No. 部品番号	Name	名称	Qt. 数量	Remarks (Also for) 備考 (適用機種)
1	202808	Model plate	型式板	1	
2	202271	Needle driving arm	針腕	1	DCR-805, 809(2mm), 885 & 889(2mm)
3	202273	" clamp	針押エ	1	DCR-805, 809, 885 & 889
4	201239A	" " screw stud	止ネジ	1	DCR-805, 809(2mm), 885 & 889(2mm)
5	201281	Presser foot	押エ	1	
6	201282A	" " chaining-off finger	爪	1	
7	201270A	" " fabric guard	補助板	1	DCR-803, 805, 809, 885 & 889
8	5030	" " " " screw	止ネジ	1	
9	202846	Main feed dog	主送り歯	1	
10	201280	Auxiliary feed dog	補助送り歯	1	
11	202847	Differential feed dog	差動送り歯	1	
12	201103-30	Feed eccentric #30	送りエキセン #30	1	
13	201103-18	" " #18	" #18	1	
14	202842	Right looper	大ルーバー #2	1	DCR-803
15	201285B	Needle guard (upper)	針受 (A)	1	DCR-805(1.5mm)
16	201286B	" " (lower)	" (B)	1	& DCR-885(1.5mm)
17	202848	Upper knife holder	上メス抱キ	1	
18	201283A	" knife	上メス	1	
19	201127	Lower knife	下メス	1	
20	201284	Upper knife chip guard	切屑押し	1	
21	201211	Needle thread eyelet, complete	針糸道 (組)	1	
22	202520	Machine top cover (right)	上カバー	1	DCR-805, 809, 885 & 889
23	201243 A	Needle thread tension guide	針糸調子台	1	
24	1732	" " " " screw	止ネジ	1	
25	202478	" " tension, complete with 201035A, 202278, 201086, 201039, 201482x2 & 5082	針糸調子 (組) 201035A, 202278, 201086, 201039, 201482x2, 5082との組	2	
26	201035 A	" " tension regulating thumb nut	針糸調子 ナット	2	
27	202278	" " " spring bushing	棒ナット止ハイフ	2	
28	201086	" " " spring	バネ (中)	2	
29	201039	" " " " cap	受皿	2	
30	201482	" " " disc	皿	4	
31	5082	" " " screw stud	棒	2	
32	3044	" " " " " nut	止ナット	2	
33	201274	" plate (0.8mm needle gauge)	針板 (針巾 0.8mm)	1	
34	201347	" " (1.2mm " " )	" (針巾 1.2mm)	1	
35	UNxR7	Needle #9 (0.8mm needle gauge)	針 #9 (針巾 0.8mm)	2	
36	UNxR12	" #12 (1.2mm " " )	" #11 (針巾 1.2mm)	2	



1



2



3

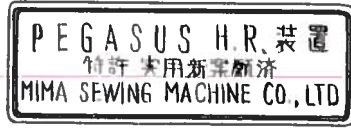

4

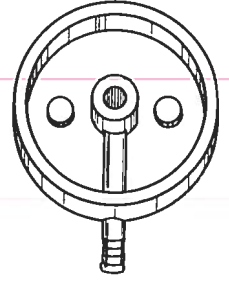

5

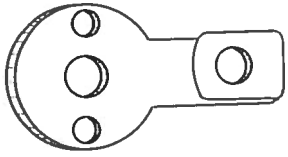

6



7

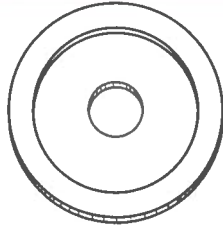

8



9



10



11



12



13



14



15



16



17



20

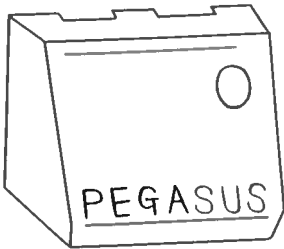

19

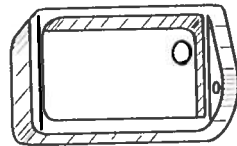

21



22



24

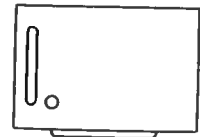

23



18

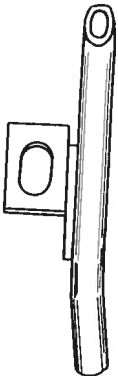

25



26



27

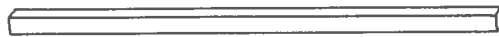

29



28

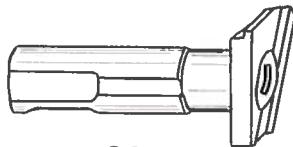

30

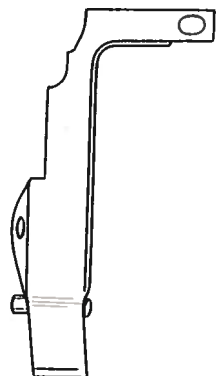

31

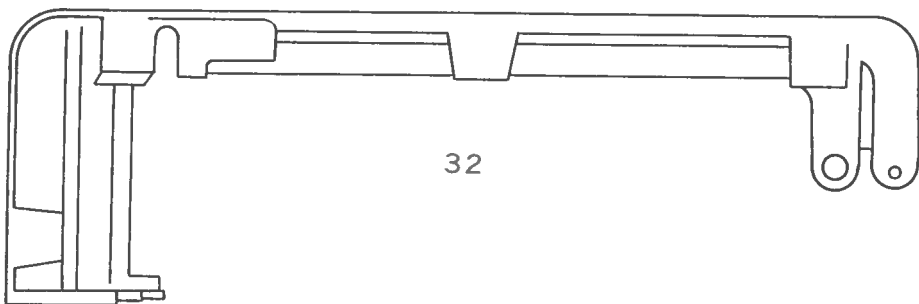

32

**PARTS FOR MODEL DCR-881, 885 & 889 ONLY**  
**DCR-881・885・889 (H.R.) 型専用部品**

Ref. No. 参照番号	Parts No. 部品番号	Name	名称	Qt. 数量	Remarks 備考
1	202880	Model plate	型式板	1	DCR-881 only用
2	202881	※ ※	※	1	DCR-885 only用
3	202882	※ ※	※	1	DCR-889 only用
4	202477	Name plate	H.R 装置マーク	1	
5	202476-1	Silicone lubricant reservoir ( upper)	シリコンタンク (上)	1	
6	202476-2	※ ※ ※ ※ bracket	※ ※ 取付板	1	
7	202476-3	※ ※ regulating thumb screw	※ ※ 油量調節棒	1	
8	202476-4	※ ※ reservoir cap cover	※ ※ 蓋	1	
9	1216	※ ※ ※ assembly screw	※ ※ 組立ネジ	2	
10	2193	※ ※ ※ screw	※ ※ 止ネジ	1	
11	202461	※ ※ ※ ※ stud	※ ※ (B) 取付棒	1	
12	202029	※ ※ tube ( vinyl)	ビニールパイプ (上)	1	
13	202878	※ ※ ※ joint screw	シリコン給油継手雄	1	
14	5020	※ ※ ※ ※ nut	※ ※ 止ナット	1	
15	200138	※ ※ ※ ※ washer	※ ※ 用パッキン	3	
16	200136	※ ※ ※ joint	※ 継手雌	1	
17	202473	※ ※ wick	※ フェルト	1	
18	200155	※ ※ tube clamp	ビニールパイプ抱パネ	2	
19	202877	Upper knife lever cover	上メス台カバー	1	
20	202468	Needle thread tube	針糸道パイプ	1	
21	202455	Silicone lubricant reservoir ( lower)	シリコンタンク (A)	1	
22	5117	※ ※ ※ ※ screw	※ ※ 止ネジ	1	
23	202456	※ ※ ※ ※ cap cover	※ ※ 蓋	1	
24	5030	※ ※ ※ ※ ※ screw	※ ※ ※ 止ネジ	1	
25	202745A	※ ※ tube, complete with 202746A & 202747A	シリコンパイプ下(組) 202746A, 202747Aとの組		
	202746A	※ ※ tube	シリコンパイプ下	1	
	202747A	※ ※ ※ bracket	※ 取付台	1	
26	5091	※ ※ ※ ※ screw	※ ※ 止ネジ	1	
27	202472	※ ※ ※ ( vinyl)	ビニールパイプ (下)	1	
28	200155	※ ※ ※ clamp	ビニールパイプ抱パネ	2	
29	200633	※ ※ wick	シリコンパイプ (下) フェルト	1	
30	202739	Lower knife holder	下メス台	1	
31	202879	Chip guard ( left)	前カバー (左)	1	
	202466	Cloth plate, complete	大カバー (組)	1	
32	202467	※ plate extension	※ 下	1	

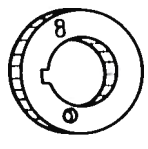

1

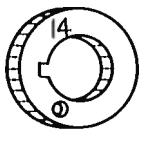

2

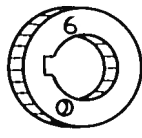

3

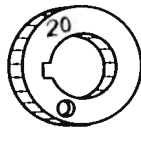

4

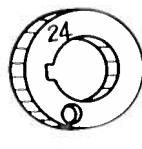

5

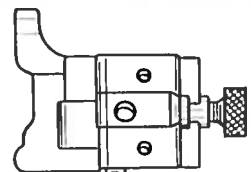

6



7

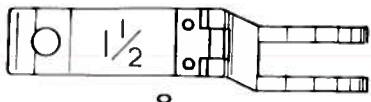

8



9



10



11



12

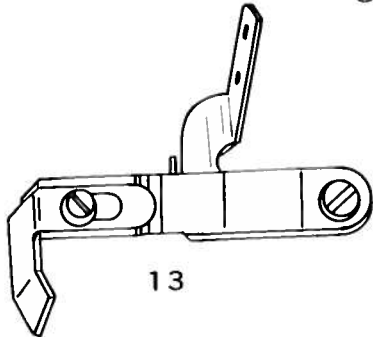

13



14



15

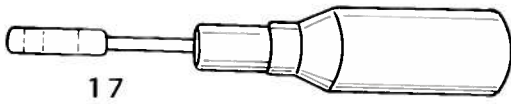

17

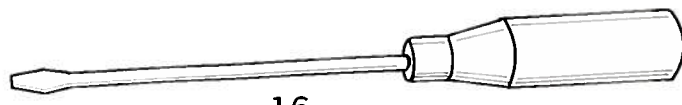

16

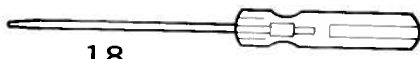

18



19



21

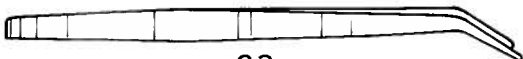

23



20

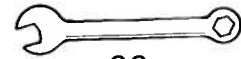

22

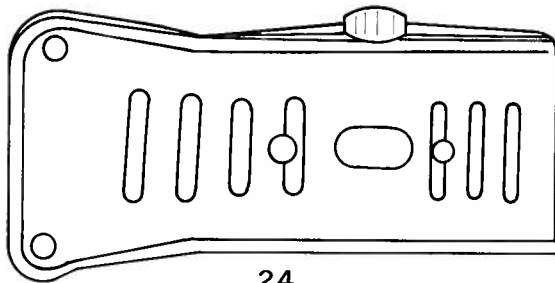

24

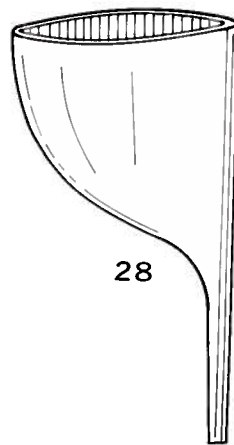

28



29



30



27

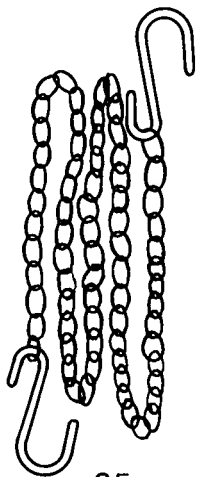

25

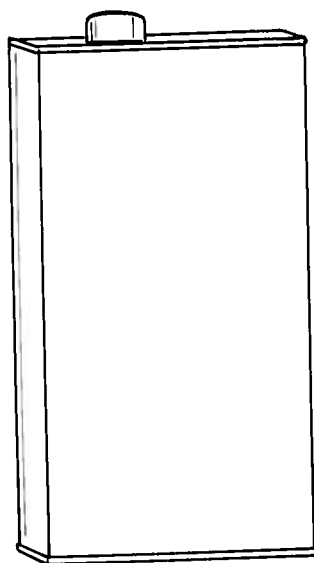

26



31



32



33



34



35



36

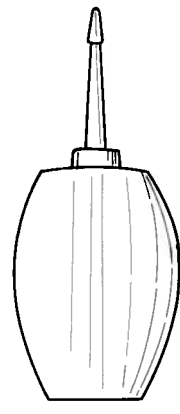

37

ACCESSORIES (1)

付属品 (1)

Ref. No.	Parts No.	Name	名称	Qt.	Remarks (Also for)
参照番号	部品番号			数量	備考 (適用機種)
1	201103-8	Feed eccentric # 8	送りエキセン # 8	1	DCR-801, 802, 805, 809, 881, & 889
2	201103-14	〃 〃 # 14	〃 # 14	1	
3	201103-6	〃 〃 # 6	〃 # 6	2	
4	201103-20	〃 〃 # 20	〃 # 20	1	DCR-810
5	201103-24	〃 〃 # 24	〃 # 24	1	
6	201499	Welt guide, complete with	201206, 201211A 2905, & 137142	1	DCR-801 & 881 (For tricot fabric, トリコット用)
	201206	〃 guide holder, complete with	201207B, 201208, 201209, 201210, 5096, 2430x4 & 5057	1	
7	1175-2	〃 guide holder screw	定規台止ネジ	1	
8	201211A	〃 guide	定規羽根	1	
9	2905	〃 〃 screw	〃 止ネジ	1	
10	137142	〃 〃 〃 washer	〃 〃 座金	1	
11	202281	〃 〃 extension	定規補助羽根	1	
12	2905	〃 〃 〃 screw	〃 止ネジ	1	
13	201500	Cloth guide, complete with	201232A, 201485, 201191, 5181, 5074, 201233A, 1202, & 137906	1	
	201232A	〃 guide holder (A)	当定規台 (A)	1	
	201485	〃 〃 〃 (B)	〃 (B)	1	
	201191	〃 〃 〃 〃 washer	〃 〃 皿バネ	1	
	5181	〃 〃 〃 〃 screw	〃 〃 止ネジ	1	
	5074	〃 〃 〃 〃 〃 nut	〃 〃 〃 ナット	1	
	201233A	〃 guide	当定規	1	
	1202	〃 〃 screw	〃 止ネジ	1	
	137906	〃 〃 〃 washer	〃 〃 座金	1	
14	127	Screw driver, large	ネジ廻シ (大)	1	
15	128	〃 〃 medium	〃 (中)	1	
16	129	〃 〃 small	〃 (小)	1	
17	201227	Socket wrench	ボックスドライバー	1	
18	201226	Feed eccentric extractor	抜取具	1	
19	130A-9.5	Wrench, 9.5mm	スパナ 9.5mm	1	
20	130A-7	〃 7mm	〃 7mm	1	
21	130A-6	〃 6mm	〃 6mm	1	
22	130A-5	〃 5mm	〃 5mm	1	
23	131	Tweezers	ピンセット	1	
24	121	Treadle, complete	靴	1	
25	126	Treadle chain	鎖	1	
26	133-7.5	Oil container (750cc)	油缶 (750cc)	1	
27	132	Oiler (plastic)	油差シ	1	
28	135A	Funnel	ジョウゴ	1	
29	202295	Lower knife	下メス	2	DCR-801, 802, 803, 805, 809, 881, 885 & 889
	201127	〃 〃	〃	2	
30	UOx154	Needle # 9	針 # 9	10	DCR-801, 802 & 881
31	UOx154	〃 # 11	〃 # 11	10	DCR-803
32	UNx154	〃 # 11	〃 # 11	10	DCR-805 & 885
33	UNx154	〃 # 14	〃 # 14	10	DCR-809 & 889
34	UNxR7	〃 # 9	〃 # 9	10	DCR-810 (0.8mm)
35	UNxR12	〃 # 11	〃 # 11	10	DCR-810 (1.2mm)
36	201486	Threading wire	糸通シ具	1	
37	178	Silicone lubricant container (50cc)	シリコン油 (50cc)	1	DCR-881, 885 & 889

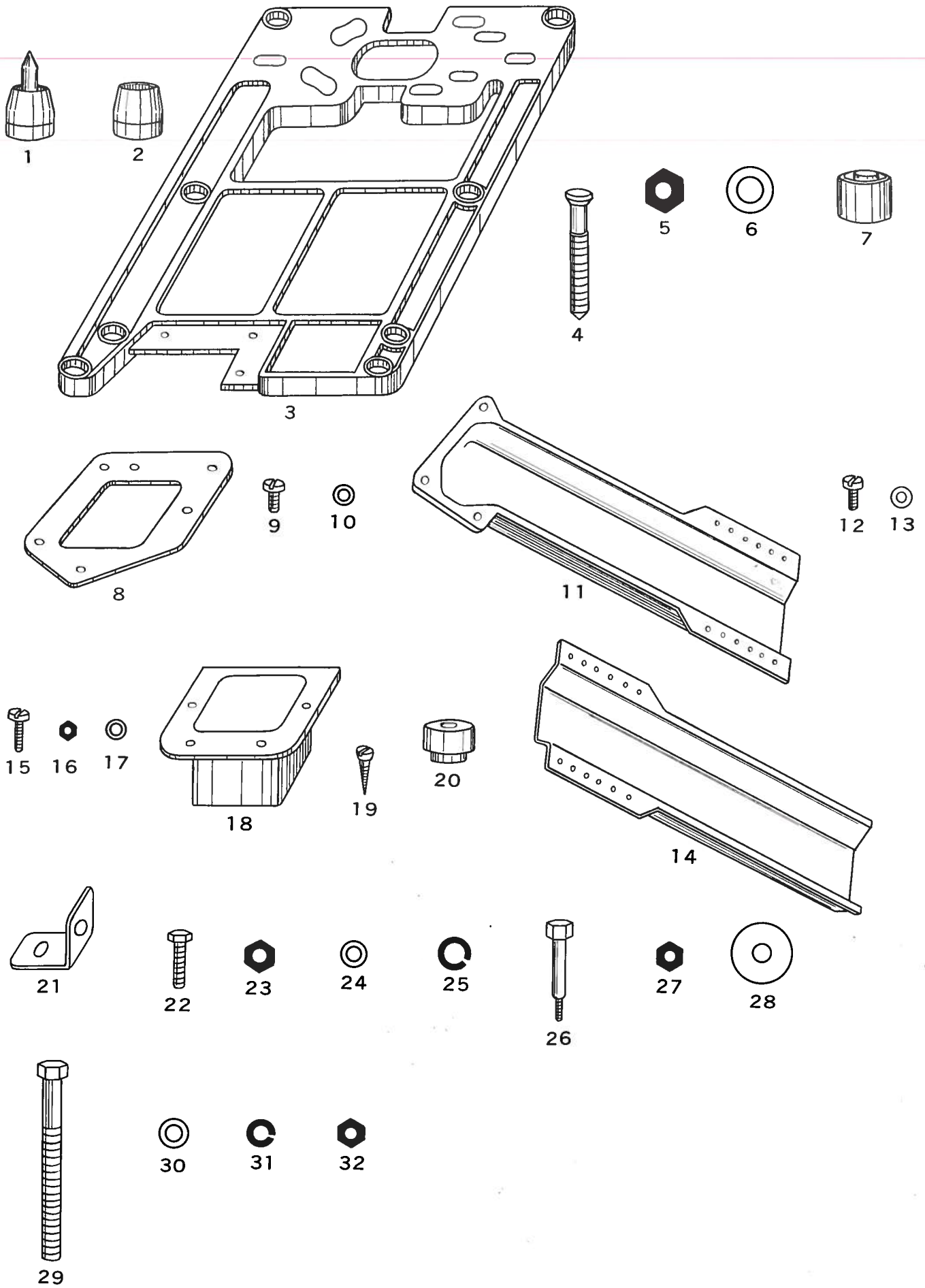





# NUMERICAL INDEX OF PARTS

## 部 品 番 号 索 引

Parts No.	Page	Ref. No.	Parts No.	Page	Ref. No.	Parts No.	Page	Ref. No.	Parts No.	Page	Ref. No.	Parts No.	Page	Ref. No.
部品番号	頁	参照番号	部品番号	頁	参照番号	部品番号	頁	参照番号	部品番号	頁	参照番号	部品番号	頁	参照番号
121	33	24	1892	9	42	5081	13	12	200138	31	15	201099	11	10
125	33	25	2022	11	24	5086	14	5	200149	17	33	201099	11	15
127	33	14	2022	13	17	5087	13	6	200155	31	18, 28	201100	11	11
128	33	15	2022	15	40	5088	5	27	200159	21	13	201100	11	16
129	33	16	2022	15	44	5088	13	19	200162	21	23	201101	11	14
130 A-5	33	22	2022-3	3	28	5089	15	25	200163	21	24	201103-5.5	25	19
130 A-6	33	21	2022-4	7	11	5091	31	26	200183	21	15	201103-6	33	3
130 A-7	33	20	2022-4	15	45	5094	23	2	200633	31	29	201103-8	33	1
130 A-9.5	33	19	2193	31	10	5094	23	24	200821	21	18	201103-10	11	20
131	33	23	2213-1	5	2	5095	11	30	201002	3	5	201103-12	11	19
132	33	27	2213-1	17	2	5095	19	2	201004	3	8	201103-14	33	2
133-7.5	33	26	2213-1	21	14	5095	23	3	201005	3	9	201103-18	29	13
135 A	33	28	2347	3	23	5097	15	50	201009	3	19	201103-20	33	4
175	35	19	2903	15	32	5099	21	17	201009	17	8	201103-24	33	5
178	33	37	2905	23	12	5109	5	46	201010 A	3	20	201103-30	29	12
1156	9	5	2905	33	9	5109	5	48	201011 C	3	22	201104	11	22
1170-1	9	2	2905	33	12	5117	15	15	201017 A	3	30	201106	11	25
1175-2	3	10	2918	23	6	5117	17	4	201018 B	3	33	201107	11	26
1175-2	3	14	2921	7	42	5117	19	12	201021 A	3	37	201109	11	27
1175-2	5	50	2921	7	45	5117	21	6	201022	3	39	201110	11	31
1175-2	7	23	2921	7	50	5117	23	9	201023	5	1	201111	13	8
1175-2	9	44	2921	9	32	5117	31	22	201025	5	5	201115A	13	9
1175-2	13	21	2921	9	35	5117	35	9	201027	5	8	201117	13	11
1175-2	17	26	2921	9	38	5117	35	12	201028	5	10	201121A	13	18
1175-2	33	7	2921	15	20	5118	21	3	201029	5	12	201125	13	24
1175-3	5	30	2921	23	14	5118	35	15	201030 A	5	14	201127	29	19
1175-3	11	28	3001	17	29	5136	3	25	201031 A	5	16	201128 C	13	26
1175-3	13	30	3018	11	21	5136	9	19	201032	5	17	201129	13	28
1175-3	13	32	3014	5	18	5136	21	20	201034 A	5	23	201130 A	13	29
1196	11	35	3014	5	38	5137	15	18	201035 A	5	32	201131 A	13	31
1202	9	40	3014	11	12	5138 A	19	19	201035 A	7	32	201132 B	13	33
1202	11	3	3014	11	17	5142	15	49	201035 A	9	22	201134	13	35
1202	11	8	3014	15	51	5142	19	15	201035 A	29	26	201141	15	7
1202	21	11	3014	21	27	5146	7	20	201037	5	34	201148 A	15	30
1202	33	13	3014	25	38	5149	19	24	201039	5	35	201152 D	15	23
1216	7	15	3014	27	13	5150	19	21	201039	7	35	201153	25	15
1216	21	10	3014	29	32	5152	17	32	201039	9	25	201154	25	18
1216	21	22	3014	35	16	5164	15	6	201039	29	29	201155 C	15	24
1216	21	29	4009-1	5	22	5181	13	7	201042	5	45	201156	15	26
1216	21	34	4009-1	13	27	5181	13	15	201043	5	49	201160 B	15	37
1216	23	11	4009-1	15	22	5184	33	13	201044	5	47	201161	15	39
1216	23	17	5002	5	15	5198	19	26	201047 B	5	39	201162 A	15	41
1216	23	20	5002	7	2	5214	3	36	201048 A	5	42	201163	15	42
1216	23	22	5002	9	3	5214	15	2	201048 A	7	30	201164 A	15	43
1216	31	9	5002	13	2	5214	15	4	201048 A	7	39	201165	15	46
1222	13	23	5010	3	34	5215 A	21	36	201048 A	9	20	201166	15	47
1229	5	44	5020	31	14	5216 B	7	25	201048 A	9	29	201167	15	48
1229	15	28	5030	25	13	5219	7	17	201068	7	34	201177 A	21	2
1231	25	11	5030	25	31	5220	7	29	201073 B	9	1	201178 A	21	4
1231	25	29	5030	27	6	5221	35	5	201074	9	4	201179 A	21	5
1231	27	4	5030	29	8	5256	15	36	201075	9	7	201180 B	21	(7)
1435	11	32	5030	31	24	5257	15	16	201076	13	14	201181 B	21	7
1435	21	25	5048	9	8	5258	15	17	201079 A	9	9	201183 A	21	8
1435	21	26	5048	9	10	5260	13	34	201080	9	11	201184	21	9
1457	5	4	5053	5	24	5261	19	3	201081	9	12	201185	21	12
1457	5	9	5060	3	21	5266	15	9	201083	9	14	201186	21	21
1457	5	11	5060	17	12	5274	9	17	201084 A	9	16	201188	21	33
1457	9	13	5060	17	15	5296	35	22	201086	9	24	201189 A	21	35
1457	9	15	5064	7	48	5297	35	23	201086	29	28	201191	21	37
1457	13	4	5074	33	(13)	5297	35	32	201088	9	39	201191	33	(13)
1457	21	31	5078	3	4	5298	35	27	201089	7	41	201200	23	15
1457-1	7	4	5080	3	31	5302	35	29	201089	9	31	201201	23	16
1457-1	13	10	5081	3	32	137142	33	10	201090	23	(10)	201202	23	18
1458	17	10	5082	5	37	137906	33	(13)	201091	9	41	201203	23	19
1458	19	25	5082	7	37	200098	11	13	201092 A	9	43	201206	33	6
1459	7	40	5082	9	27	200098	11	18	201093 A	11	1	201211 A	33	8
1459	9	30	5082	29	31	200098	35	10	201094 B	11	2	201212 A	3	27
1732	25	36	5084	5	6	200098	35	13	201096 A	11	6	201221	21	16
1732	27	11	5084	5	13	200098	35	17	201097 B	11	7	201224 B	25	3
1732	29	24	5084	7	13	200136	31	16	201098	11	9	201224 B	25	9

Parts No.	Page	Ref. No.	Parts No.	Page	Ref. No.	Parts No.	Page	Ref. No.	Parts No.	Page	Ref. No.	Parts No.	Page	Ref. No.
部品番号	頁	参照番号	部品番号	頁	参照番号	部品番号	頁	参照番号	部品番号	頁	参照番号	部品番号	頁	参照番号
201226	33	18	201324	19	7	202461	31	11	202678	27	26	202867	23	4
201227	33	17	201325 B	19	23	202466	31	(32)	202679	27	32	202868	15	38
201230 B	25	8	201327	19	8	202467	31	32	202684	25	5	202870	3	29
201230 B	25	26	201328	19	13	202468	31	20	202685	25	6	202871	15	34
201230 B	27	21	201329	19	11	202472	31	27	202687	3	15	202872	27	14
201232 A	33	(3)	201330	3	6	202473	7	26	202691	35	1	202874	7	28
201233 A	33	(3)	201334 B	19	16	202473	31	17	202692	35	(1)	202875	7	43
201235	23	(2)	201335	19	17	202476-1	31	5	202693 A	35	7	202875	7	46
201236	23	(2)	201338	17	23	202476-2	31	6	202697 C	35	3	202875	9	33
201239 A	25	24	201341	17	25	202476-3	31	7	202700	35	6	202875	9	36
201239 A	27	19	201342 B	17	27	202476-4	31	8	202709 A	7	9	202877	31	19
201239 A	29	4	201345 A	17	28	202477	31	4	202710 A	7	10	202878	31	13
201241	25	33	201346 A	35	18	202478	5	31	202711 A	5	3	202879	31	31
201241	27	8	201347	29	34	202478	25	37	202711 A	7	3	202880	31	1
201241	29	21	201348 B	35	11	202478	27	12	202711 A	13	3	202881	31	2
201243 A	25	35	201349 B	35	14	202478	29	25	202712 A	7	12	202882	31	3
201243 A	27	10	201360	13	5	202479	7	31	202713	7	8	204303	35	4
201243 A	29	23	201380 A	13	1	202480	9	21	202715 A	35	8	UNx154 #1125	45	
201248 B	5	25	201386 B	25	27	202491	5	28	202720 B	3	11	UNx154 #1133	32	
201249 B	5	26	201461 A	27	21	202492	5	29	202722 A	17	13	UNx154 #1427	33	
201250 B	25	42	201473	25	2	202501	3	2	202726 A	3	38	UNx154 #14	33	33
201250 B	27	27	201477	35	25	202502 B	15	1	202739	31	30	UNxR7 #9	29	35
201251 B	25	44	201477	35	31	202503	15	3	202745 A	31	25	UNxR7 #9	33	34
201251 B	27	29	201482	5	36	202504 A	15	21	202746 A	31	(25)	UNxR12 #11	29	36
201259	27	31	201482	7	36	202505	15	5	202747 A	31	(25)	UNxR12 #11	33	35
201263 A	27	20	201482	9	26	202507	15	29	202748	23	25	UOx154 #9	5	51
201264 A	27	22	201482	29	30	202510	15	33	202757	7	14	UOx154 #9	33	30
201265 B	25	10	201485	33	(3)	202511	15	35	202761	35	2	UOx154 #11	25	20
201265 B	25	28	201486	33	36	202512 A	15	27	202762	23	(2)	UOx154 #11	33	31
201265 B	27	3	201487	19	18	202513	21	28	202765	35	20			
201267 B	27	28	201499	33	(6)	202514	23	1	202766	35	26			
201268 B	27	30	201500	33	13	202516	23	5	202767	35	28			
201270 A	25	12	201758	19	10	202517	23	8	202768	35	21			
201270 A	27	5	201759	19	5	202518	15	31	202769	35	24			
201270 A	29	7	201759	19	9	202520	25	34	202769	35	30			
201270 A	25	30	202029	31	12	202520	27	9	202800	3	1			
201274	29	33	202081	7	6	202520	29	22	202801	3	7			
201280	29	10	202081	7	27	202521	21	30	202802	25	1			
201281	29	5	202200	11	23	202522	21	32	202803	25	4			
201282 A	29	6	202201 A	11	29	202524	15	10	202804	25	21			
201283 A	29	18	202202	11	33	202575	15	8	202807	27	1			
201284	29	20	202203	11	34	202576	15	11	202808	29	1			
201285 B	25	41	202208	19	11	202577	15	12	202822 A	3	18			
201285 B	29	15	202271	25	22	202578	15	14	202824 B	3	24			
201286 B	25	43	202271	27	15	202579	23	7	202825	5	7			
201286 B	29	16	202271	29	2	202589	15	13	202826	5	43			
201288 A	17	1	202272	27	16	202616	5	19	202827	7	18			
201293 A	17	3	202273	25	23	202617	5	20	202829	7	47			
201294	17	5	202273	27	2	202618	5	21	202830 A	9	37			
201295	17	6	202273	29	3	202619 A	7	1	202834 A	21	1			
201296	17	7	202274	25	25	202622 B	7	5	202838	23	21			
201297	17	9	202274	27	17	202623 A	7	7	202839	23	(2)			
201298	17	11	202275	27	18	202625	7	19	202842	25	14			
201299	17	14	202278	5	33	202626 A	7	16	202842	29	14			
201300	17	16	202278	7	33	202627 A	7	21	202843	23	10			
201301	17	17	202278	9	23	202628 B	7	22	202846	29	9			
201302	17	18	202278	29	27	202629 B	7	24	202847	29	11			
201303	17	19	202281	33	11	202634	11	4	202848	29	17			
201304	17	21	202286	5	40	202635	13	13	202849	7	38			
201310 A	27	23	202286	9	6	202636	13	16	202849	9	28			
201311	17	24	202287	19	20	202637 A	13	20	202854	25	17			
201315	17	30	202288	3	35	202638 A	13	22	202854	25	32			
201316	17	31	202295	13	25	202660	23	13	202854	27	7			
201318 A	23	23	202295	33	29	202662	3	12	202858	7	49			
201319	17	20	202297	5	41	202663 D	3	13	202859	7	44			
201320	19	22	202354	3	16	202669	25	7	202860	9	34			
201320-1	17	22	202371	3	3	202671	25	16	202861	9	18			
201321	19	1	202451	15	19	202674	25	39	202863	3	17			
201322	19	4	202455	31	21	202675	25	40	202864	3	26			
201323	19	6	202456	31	23	202675	27	25	202865	21	19			

