PFAFF[®] **5483**



Bei lackierten Teilen bitte Farbe angeben
For paint-finished parts please state colour
Pour les pièces peintes préciser réf. et couleur
En el caso de piezas barnizadas, indíquese el color

Bestandteileliste

List of spare parts

Liste de pièces détachées

Lista de piezas de repuesto

Die Inhaltsübersicht auf Seite 3 gibt einen Überblick über die Aufgliederung der Liste.
 Die Teile sind so abgebildet, wie sie in der Maschine funktionsmäßig zusammengehören.
 Die gestrichelten Abbildungen zeigen, wo die daneben abgebildeten Teile hingehören.
 Die Einrahmungen auf den Bildseiten zeigen, aus welchen Einzelteilen sich die Gruppenteile zusammensetzen.
 Nähwerkzeuge und Apparate sind der Unterklassen-Ausstattung zu entnehmen (siehe Anhang).
 Die auf den Bildseiten verwendeten Schlüsselzeichen (□; 2; 3 usw.) sind in Register „0“ zusammengefaßt und erläutert.
 Das Erstellungsdatum ist auf den einzelnen Seiten oben rechts angegeben. Bei Austausch bitte Datum beachten.
 Konstruktionsänderungen vorbehalten.

For the various sections of this catalogue, please refer to the "Contents" on page 3.
 The parts are illustrated as they belong together in the machine.
 The dashed illustrations show where the adjacent parts belong.
 The framed-in sections on the illustration pages show the individual parts comprising a group.
 For sewing parts and attachments please refer to the subclass listing (see appendix).
 The reference keys (□; 2; 3 etc.) used on the illustration pages are compiled and explained in section "0".
 The date of preparation of the individual pages is indicated in the upper right-hand corner. Please note the new date on revised sheets.
 Subject to alterations in design.

La table des matières, page 3, donne un aperçu de la subdivision de la liste.
 Les pièces figurent sur l'illustration comme elles vont ensemble.
 Les figures en tirets montrent le lieu de montage des pièces figurant à côté.
 Les parties encadrées sur les pages à illustrations représentent les pièces individuelles formant groupe.
 Pour les organes de couture et les appareils, veuillez vous référer à la fiche équipement de sous-classes (voir en annexe).
 Les symboles (□; 2; 3 etc.) utilisés sur les pages illustrées sont regroupés et expliqués au registre „0“.
 La date de parution des différentes planches est indiquée dans l'angle supérieur droit. Veiller à toujours n'utiliser que les planches les plus récentes.
 Sous réserve de modifications.

En la página 3, bajo el título "contenido", puede verse un resumen de la división de la "lista de piezas".
 Las piezas están ilustradas conforme se hallan montadas en la máquina.
 Las figuras a base de líneas entrecortadas muestran dónde y cómo van montadas las piezas ilustradas al lado.
 Los recuadros en las páginas ilustradas indican las piezas individuales de que se componen los grupos.
 Para los órganos de costura y aparatos, véase la „Composición de las subclases“ (en el anexo).
 Los símbolos clave (□; 2; 3, etc.) utilizados en las páginas ilustradas se hallan recopilados y explicados en el registro „0“.
 La fecha en que cada una de las páginas ha sido editada se halla indicada en la esquina derecha superior. Al reemplazar unas hojas por otras se ruega tener en cuenta la fecha.
 Salvo modificaciones técnicas.



Register Section Registre Registro			Seite Page Página	
	Schmiermittel-Tabelle Table of lubricants Tableau des lubrifiants Tabla de lubricantes		7	
0	Erläuterungen Explanations Légende Explicaciones		8 10 12 14	
0.1	Verschleiß- und Depotteile Wear parts and distributor stock parts Pièces d'usure et en stock chez le distributeur Piezas de desgaste y piezas para almacenar en la representación		16	
1	Kopfteile Front parts Pièces de tête Piezas de la cabeza	Pfaff 5483-814/01	Einnadel und Zweinadel Single-needle and two-needle Une aiguille et deux aiguilles Aguja única y dos agujas	18
2	Armteile Arm parts Pièces de bras Piezas del brazo	Pfaff 5483-814/01		22
3	Grundplattenteile Bedplate parts Pièces du plateau fondamental Piezas de la placa-base	Pfaff 5483-814/01		28
4	Gehäuseteile Housing sections Parties du corps Piezas del cárter			35
5	Ergänzungsteile Complementary parts Pièces complémentaires Piezas complementarias	Pfaff 5483 R-814/01	Einnadel Single-needle Une aiguille Aguja única	36
6	Ergänzungsteile Complementary parts Pièces complémentaires Piezas complementarias	Pfaff 5483 H-814/01-704/02*)	Zweinadel Two-needle Deux aiguilles Dos agujas	39
	Ergänzungsteile Complementary parts Pièces complémentaires Piezas complementarias	Pfaff 5483 H-814/01-704/02*)	Dreinadel Three-needle Trois aiguilles Tres agujas	39
7	Ergänzungsteile Complementary parts Pièces complémentaires Piezas complementarias	Pfaff 5483 H-814/01-911/03 Pfaff 5483 H-814/01-911/05 Pfaff 5483 H-814/01-910/04-911/05	Einnadel Single-needle Une aiguille Aguja única	44
8	Ergänzungsteile Complementary parts Pièces complémentaires Piezas complementarias	Pfaff 5483 HO-814/01-749/01	Einnadel Single-needle Une aiguille Aguja única	58
9	Ergänzungsteile Complementary parts Pièces complémentaires Piezas complementarias	Pfaff 5483 HO-814/01-944/01	Einnadel Single-needle Une aiguille Aguja única	64
10	Ergänzungsteile Complementary parts Pièces complémentaires Piezas complementarias	Pfaff 5483 HO-814/02	Zweinadel Two-needle Deux aiguilles Dos agujas	66
11	Ergänzungsteile Complementary parts Pièces complémentaires Piezas complementarias	Pfaff 5483-814/06	Zweinadel Two-needle Deux aiguilles Dos agujas	68



*) Nur in Verbindung mit Unterklasse -748/56-960/11
Only in conjunction with subclass -748/56-960/11
Uniquement en liaison avec la sous-classe -748/56-960/11
Sólo en combinación con la subclase -748/56-960/11

Register Section Registre Registro		Seite Page Página			
12	Ergänzungsteile Complementary parts Pièces complémentaires Piezas complementarias	Pfaff 5483-818/55 — Pfaff 5483-818/56 —	Zweinadel · Two-needle Deux aiguilles · Dos agujas Dreinel · Thre-needle Trois aiguilles · Tres agujas	70	
	Apparate-Antrieb Attachment drive Commande d'appareils Mecanismo para accionamiento de aparatos	-703/01	zur for Pfaff 5483-814/01-733/11-39/21 pour Pfaff 5483-814/01-733/12-39/21 para		76
14	Kanten-Beschneideinrichtung Edge trimmer Couteau Recortador	-731/01 -731/11 -731/12		78	
	Kanten-Beschneideinrichtung Edge trimmer Couteau Recortador	-733/01 -733/11 -733/12			88
	Walzentransport-Einrichtung Puller feed Puller Puller	-748/56			
17	Fadenabschneid-Einrichtung Thread trimmer Coupe-fil Cortahilos	-900/11		104	
	Fadenabschneid-Einrichtung Thread trimmer Coupe-fil Cortahilos	-900/51			110
	Fadenabschneid-Einrichtung Thread trimmer Coupe-fil Cortahilos	-900/71 -900/71-910/04*)			
20	Fadenspannungs-Steuerung Thread tension control Commande de la tension du fil Control de la tensión del hilo superior	-906/02		120	
	Presserfuß-Automatik Automatic presser foot lifter Relève-pied automatique AlzaprensateLAS	-910/01			120
	Presserfuß-Automatik Automatic presser foot lifter Relève-pied automatique AlzaprensateLAS	-910/04			
23	Presserfuß-Automatik Automatic presser foot lifter Relève-pied automatique AlzaprensateLAS	-910/24		124	
	Verriegelungs-Einrichtung Backtacking device Dispositif à points d'arrêt Rematador	-911/15 -911/35			127
	Verriegelungs-Einrichtung Backtacking device Dispositif à points d'arrêt Rematador	-911/95			
25	Stichverdichtungs-Einrichtung Stitch condensation mechanism Rétrécisseur de points Condensador de puntadas	-910/04*)-917/05 -917/05		132	
					132

Register Section Registre Registro		Seite Page Página	
27	Stichverdichtungs-Einrichtung Stitch condensation mechanism -917/15 Rétrécisseur de points -917/35 Condensador de puntadas	138	
28	Blasvorrichtung Blower -920/03 Dispositif à jet d'air Eyector de aire	142	
29	Blasvorrichtung Blower -920/05 Dispositif à jet d'air Eyector de aire	143	
30	Blasvorrichtung Blower -920/11 Dispositif à jet d'air Eyector de aire	144	
31	Wartungseinheit Air filter/lubricator -925/01; -925/02; -925/03 Conditionneur d'air comprimé Grupo acondicionador del aire comprimido	145	
32	Rollfuß-Einrichtung Roller presser -944/01 Dispositif à pied à roulette Pie rodante	148	
33	Kettentrenn-Einrichtung Chain cutter -960/11 Coupe-chaînette -960/14 Cortador de cadeneta	149	
34	Kettentrenn-Einrichtung -960/20 Chain cutter -960/21 Coupe-chaînette -960/22 Cortador de cadeneta -960/24	156	
35	Bandtrenn-Einrichtung Tape cutter -960/61 Coupe-ruban -960/62 Cortador de cintas -960/64	166	
36	Bandtrenn-Einrichtung Tape cutter -960/81 Coupe-ruban -960/82 Cortador de cintas -960/84	176	
37	Fotozellensteuerung für Verriegelung -971/01 -971/02 Fotocélula	Fotozelle Photocell Cellule photo-électrique Fotocélula -910/04 -911/15 -925/02	183 122 127 146
	Photocell control for backtacking -971/21 -971/22 Fotocélula	Fotozelle Photocell Cellule photo-électrique Fotocélula -910/04 -911/35 -925/02	183 122 127 146
	Commande par cellule photo-électrique pour points d'arrêt -971/23 -971/24 Fotocélula	Fotozelle Photocell Cellule photo-électrique Fotocélula -911/95	183 131
	Mando por fotocélula para rematado		

Register Section Registre Registro		Seite Page Página		
37	Fotozellensteuerung für Stichverdichtung	-971/41	Fotozelle Photocell Cellule photo-électrique Fotocélula -910/04 -917/15 -925/02	183 122 138 146
	Photocell control for condensed stitching			
	Commande par cellule photo-électrique pour points rétrécis		Fotozelle Photocell Cellule photo-électrique Fotocélula -910/04 -917/35 -925/02	183 122 138 146
	Mando por fotocélula para condensación de la puntada	-971/61		
38	Zubehörteile Accessory parts Accessoires Accesorios			185
39	Einstellehren Adjustment gauges Calibres Calibres de ajuste			187
40	Nadelsystem-Tabelle Table of Needle system Tableau des systèmes d'aiguilles Tabla de sistema de agujas			188
41	Fadenöler Thread lubricator Graisseur de fil Lubricador del hilo			189
42	Rückwärtsnäh-Einrichtung Reverse sewing mechanism Marche arrière Dispositivo para inversión de costura		zur for pour para	Pfaff 5483 H-911/.. 190
43	Motoranschlußsatz Motor connection kit Jeu de pièces à raccorder le moteur Juego de piezas para conexión del motor		(Ausrüstung mit Motorschutzschalter) (equipment with motor overload trip) (avec contacteur-disjoncteur) (con interruptor de seguridad)	192
44	Motoranschlußsatz Motor connection kit Jeu de pièces à raccorder le moteur Juego de piezas para conexión del motor		(Ausrüstung mit Motordrehschalter) (equipment with motor turn switch) (avec interrupteur rotatif) (con interruptor giratorio)	194
45	Positionsgeber Synchronizer Synchronisateur Sincronizador	zur for pour para	Pfaff 5483-900/51; -900/71; -913/52	195
46	Keilriemenscheiben-Tabelle Table of V-belt pulleys Tableau des poulies à gorge en V Tabla de poleas para correas en „V”			196
47	Nummernverzeichnis Numerical index Tableau des numéros Indice numérico			197
Anhang Appendix Annexe Anexo	Unterklassen-Ausstattung Subclass parts Composition des sous-classes Composición de las subclases			

Öl Oil Huile Aceite	Viskosität bei: Viscosity of: Viscosité à: Viscosidad a:		Dichte bei: Density of: Densité à: Densidad a:		Bestellnummer für Behälter mit: Ordering number for can containing: Numéro de commande pour récipients avec: Número de pedido para recipientes con:			
	°C	mm ² /s	°C	g/cm ³ (g/ml)	Liter Litre Litros			
280-1-120 144	50	15,0	15	0,865	0,09	91-129 138-91		
					0,25		91-129 916-91	
					1		91-129 917-91	
					5			91-129 919-91
					10			91-129 920-91
280-1-120 217	20	11,8			0,09			
					0,25			
					1		91-129 941-91	
					5			
					10			
					0,09			
					0,25			
					1			
					5			
					10			

Fett Grease Graisse Grasa	Penetration Penetration Pénétration Penetración		Tropfpunkt Drip-point Point de suintement Punto de goteo		Bestellnummer für Behälter mit: Ordering number for can containing: Numéro de commande pour récipients avec: Número de pedido para recipientes con:			
	mm/10		°C		kg			
280-1-120 243	375-405		150		0,5	280-1-120 243		
					1			
280-1-120 247	220-250		185		0,5			
					1		280-1-120 247	
280-1-120 239	260		190		0,5			
					1		280-1-120 239	

00-000 000-00

Hauptgruppenteil, bestehend aus: Gruppenteilen oder Gruppenteilen und Einzelteilen oder Gruppenteilen, Einzelteilen und Einzelteilen mit Ergänzung. (Siehe Einrahmungen auf den Bildseiten.)

00-000 000-00

Gruppenteil, bestehend aus: Einzelteilen oder Einzelteilen und Einzelteilen mit Ergänzung. (Siehe Einrahmungen auf den Bildseiten.)

00-000 000-00

Einzelteil mit Ergänzung (siehe Einrahmungen auf den Bildseiten)
z.B. Stelling mit Schrauben, Nadelstange mit Befestigungsschraube zur Nadel, usw.

00-000 000-00

Einzelteil

A

Ausführung A

B

Ausführung B

C

Ausführung C

4,5

Stichlänge 4,5 mm

N

Stichlänge 6,0 mm

Unterklassenabhängig, Teilenummer siehe Unterklassen-Ausstattung.

0

Unterklassenzugehörigkeit siehe Unterklassen-Ausstattung.

2

Markierung (Punkte, Striche oder Zahl) bei Bestellung angeben.

3

Geklebt

3/1

Gesichert mit Loctite

3/3

Selbstklebende Folie

3/11

Mit Dichtungsmasse, epple 22, bestreichen.

4

Ausführungsart bei Bestellung angeben.

5

Nähmuster einsenden

6

Nadeldicke und Spitzenform bei Bestellung angeben.

7/14

Für Messer rechts der Nadel

7/15

Für Messer mitte der Nadel

7/16

Für Messer links der Nadel

7/23

Untermesser mit Hartmetallschneide.

8/2

Schneidlänge bei Bestellung angeben.

9

Schneidabstand

9/2

Schneidabstand bei Bestellung angeben.

10

Nadelabstand

10/2

Nadelabstand bei Bestellung angeben.

16/2

Auszackbreite bei Bestellung angeben.

22

Zubehör

26/10

Zur Stichlängenbegrenzung

27/2

Eingeklammerte Zahl = Stärke in mm.

27/5

Eingeklammerte Zahl = Länge in mm.

27/12

Eingeklammerte Zahl = Durchmesser x Breite in mm.

27/17

Eingeklammerte Zahl = Dicke in mm.

28

Sonderausführung

28/5

Sonderbestellung

30

Frühere Ausführung, im Ersatzfall wieder bestellen.

30/0

Nicht mehr im Programm.

30/1

Frühere Ausführung, zur Reparatur einsenden.

30/2

Frühere Ausführung, ersetzt durch Nr. 91-168 858-12.

30/3

Frühere Ausführung, ersetzt durch neue Ausführung Nr. 91-171 283-91 und 91-172 958-91.

30/4

Frühere Ausführung, ersetzt durch Nr. 91-171 904-91.

30/5

Frühere Ausführung, ersetzt durch Nr. 91-174 142-11.

30/6

Frühere Ausführung, ersetzt durch Nr. 91-028 955-15; 91-100 338-15; 91-174 033-05.

30/8

Frühere Ausführung, ersetzt durch Nr. 91-171 465-91 und 91-171 744-05 (siehe Seite 33).

- 30/9** Frühere Ausführung, ersetzt durch Nr. 15-120 800-05; 91-175 539-05.
- 30/10** Frühere Ausführung, ersetzt durch neue Ausführung Nr. 91-172 093-11.
- 30/11** Frühere Ausführung, ersetzt durch Nr. 91-087 144-91.
- 30/12** Frühere Ausführung, ersetzt durch Nr. 99-134 850-91.
- 30/13** Frühere Ausführung, ersetzt durch Nr. 91-171 462-70/993 (siehe Seite 146).
- 30/18** Frühere Ausführung, ersetzt durch Nr. 91-178 019-91 (siehe Seite 169).
- 31** Einzel nicht austauschbar, im Ersatzfall vollständiges Aggregat (eingerahmte Teile) bestellen, oder zur Reparatur einsenden.
- 31/1** Einzel nicht lieferbar
- 32** Beim Einbau dieses Teiles wird für die Paßgenauigkeit zum Anschlußteil keine Garantie übernommen; zweckmäßig vollständiges Aggregat bestellen.
- 32/1** Beim Einbau dieses Teiles ist Nacharbeit erforderlich.
- 35/1** Bei Montage vernieten.
- 38/7** Kunststoffbeschichtet
- 38/8** Gezahnt
- 40/1** Füllen mit 280-1-120 144, Bestellnummer siehe Seite 7.
- 40/2** Tränken mit 280-1-120 144, Bestellnummer siehe Seite 7.
- 40/3** Fetten mit 280-1-120 247, Bestellnummer siehe Seite 7.
- 40/4** Fetten mit 280-1-120 243, Bestellnummer siehe Seite 7.
- 40/5** Ölen mit 280-1-120 144, Bestellnummer siehe Seite 7.
- 40/6** Füllen mit 280-1-120 217, Bestellnummer siehe Seite 7.
- 40/11** Fetten mit 280-1-120 239, Bestellnummer siehe Seite 7.
- 60** Wahlweise
- 80/4** Für Schlauch mit 4 mm Innendurchmesser.
- 80/6** Für Schlauch mit 6 mm Innendurchmesser.
- 81/3** Verwendung je nach Bedarf.
- 90/1** Für Wechselstrom
- 90/2** Für Drehstrom
- 90/3** Zur Motorbefestigung
- 90/4** Verwendung nur bei 420 V.
- 90/7** Langsamnäheinrichtung abschaltbar.
- 90/8** In Verbindung mit Unterklasse -910/.. Nr. 71-59 00-0237.
- 90/9** Für Motoren mit 8-stelliger Typennummer.
- 90/11** Für Elektronik-Stop-Motoren
- 90/12** Für Kupplungsmotoren
- 90/13** Für Hebel-Stop-Motoren
- 90/19** Wartungseinheit -925/.. erforderlich.
- 90/23** Zum Befestigen von Nr. 91-177 464-45 am Einständer-Gestell.
- 90/31** Rückwärtsnäheinrichtung erforderlich (siehe Seite 190).
- 90/32** Zur Fadenspannung Nr. 91-170 275-91 (siehe Seite 22).
- 90/33** Zur Fadenspannung Nr. 91-170 275-91 (siehe Seite 22), an Stelle von Nr. 91-010 183-05.
- 90/34** Für Blechprofil-Gestell
- 90/35** Für Einständer-Gestell
- 95/2** x-Wert = Schneidlänge in mm, bei Bestellung angeben.
- 95/3** x-Wert = Dicke in mm, bei Bestellung angeben.
- 95/5** x-Wert = Nadelabstände
- 96** Länge angeben
- 96/3** Schlauch mit 3 mm Innendurchmesser, bei Bestellung Länge angeben.
- 96/4** Schlauch mit 4 mm Innendurchmesser, bei Bestellung Länge angeben.
- 96/6** Schlauch mit 6 mm Innendurchmesser, bei Bestellung Länge angeben.
- 96/10** Länge x Breite angeben.
- 96/25** Schlauch mit 2,5 mm Innendurchmesser, bei Bestellung Länge angeben.

00-000 000-00

Assembly, consisting of: sub-assemblies or sub-assemblies and component parts or sub-assemblies, component parts and component plus complementary parts. (See the framed-in sections on the illustration pages.)

00-000 000-00

Sub-assembly, consisting of: component parts or component parts and component plus complementary parts. (See the framed-in sections on the illustration pages.)

00-000 000-00

Component part with complementary parts (see the framed-in sections on the illustration pages), e.g. collar with screws, needle bar with needle set screw, etc.

00-000 000-00

Component part

- A** Model A
- B** Model B
- C** Model C
- 4,5** Stitch length 4.5 mm
- N** Stitch length 6.0 mm
- Subclass-dependent, for part number see subclass parts listing.
- 0** For subclass see subclass parts listing.
- 2** Marking (dots, strokes or numbers) to be stated on order.
- 3** Part cemented
- 3/1** Secured with Loctite
- 3/3** Self-adhesive foil
- 3/11** Apply sealing compound, epple 22
- 4** Model to be stated on order.
- 5** Submit sewing sample.
- 6** Needle size and style of point to be stated on order.
- 7/14** For knife set to the right of the needle.
- 7/15** For knife set opposite the needle.
- 7/16** For knife set to the left of the needle.
- 7/23** Lower knife with carbide cutting edge.
- 8/2** Cutting length to be stated on order.
- 9** Trimming margin
- 9/2** Trimming margin to be stated on order.
- 10** Needle gauge
- 10/2** Needle gauge to be stated on order.
- 16/2** Pinking margin to be stated on order.
- 22** Accessories.
- 26/10** For stitch length limitation.
- 27/2** Number in parentheses = thickness in mm.
- 27/5** Number in parentheses = length in mm.
- 27/12** Number in parentheses = diameter x width in mm.
- 27/17** Number in parentheses = thickness in mm.
- 28** Special version
- 28/5** Special order
- 30** Earlier version, to be re-ordered for replacement purposes.
- 30/0** No longer produced.
- 30/1** Earlier version, return for repair.
- 30/2** Earlier version, replaced by No. 91-168 858-12.
- 30/3** Earlier version, replaced by new version No. 91-171 283-91 and No. 91-172 958-91.
- 30/4** Earlier version, replaced by No. 91-171 904-91.
- 30/5** Earlier version, replaced by No. 91-174 142-11.
- 30/6** Earlier version, replaced by No. 91-028 955-15; 91-100 338-15; 91-174 033-05.
- 30/8** Earlier version, replaced by Nos. 91-171 465-91 and 91-171 744-05, (see page 33).

- 30/9** Earlier version, replaced by No. 15-120 800-05; 91-175 539-05.
- 30/10** Earlier version, replaced by new version No. 91-172 093-11.
- 30/11** Earlier version, replaced by No. 91-087 144-91.
- 30/12** Earlier version, replaced by No. 99-134 850-91.
- 30/13** Earlier version, replaced by No. 91-171 462-70/993 (see page 146).
- 30/18** Earlier version, replaced by No. 91-178 019-91 (see page 169).
- 31** Cannot be exchanged singly; if defective, order complete assembly (boxed-in parts) or return same for repair.
- 31/1** Cannot be supplied singly.
- 32** No guarantee is assumed that this part will fit the mating part; it is best to order a complete assembly.
- 32/1** When fitting this part re-work is required.
- 35/1** To be riveted after assembly.
- 38/7** Plastic-coated
- 38/8** Toothed
- 40/1** Top up 280-1-120 144; for stock number see page 7.
- 40/2** Soak with 280-1-120 144; for stock number see page 7.
- 40/3** Grease with 280-1-120 247; for stock number see page 7.
- 40/4** Grease with 280-1-120 243; for stock number see page 7.
- 40/5** Oil with 280-1-120 144; for stock number see page 7.
- 40/6** Top up with 280-1-120 217; for stock number see page 7.
- 40/11** Grease with 280-1-120 239; for stock number see page 7.
- 60** Optional
- 80/4** For tube with 4 mm inside diameter.
- 80/6** For tube with 6 mm inside diameter.
- 81/3** To be used, as required.
- 90/1** For single-phase A.C.
- 90/2** For three-phase A.C.
- 90/3** For fitting the motor.
- 90/4** To be used on 420-volt, three-phase A.C. only.
- 90/7** Disengageable inching device.
- 90/8** In conjunction with subcl. -910/.. No. 71-59 00-0237.
- 90/9** For motors with 8-digit model number.
- 90/11** For electronic Stop motors
- 90/12** For clutch motors
- 90/13** For lever-operated Stop motors
- 90/19** Conditioning unit -925/.. required.
- 90/23** For fastening part No. 91-177 464-45 on the pedestal stand.
- 90/31** Reverse-sewing mechanism required (see page 190).
- 90/32** For thread tension No. 91-170 275-91 (see page 22).
- 90/33** For thread tension No. 91-170 275-91 (see page 22) instead of No. 91-010 183-05.
- 90/34** For tubular-steel stand.
- 90/35** For the pedestal stand.
- 95/2** x value (= cutting length in mm) to be stated on order.
- 95/3** x value (= thickness in mm) to be stated on order.
- 95/5** x value = Needle gauge
- 96** State length
- 96/3** Tube with 3 mm inside dia.; length to be stated on order.
- 96/4** Tube with 4 mm inside dia.; length to be stated on order.
- 96/6** Tube with 6 mm inside dia.; length to be stated on order.
- 96/10** State length x width.
- 96/25** Tube with 2.5 mm inside dia.; length to be stated on order.

00-000 000-00

Groupe principal de pièces, comprenant: des groupes de pièces ou des groupes de pièces et des pièces détachées ou des groupes de pièces, des pièces détachées et des pièces détachées avec des pièces complémentaires.
(Voir parties encadrées sur illustrations.)

00-000 000-00

Groupe de pièces, comprenant: des pièces détachées ou des pièces détachées et des pièces détachées avec pièces complémentaires.
(Voir parties encadrées sur illustrations.)

00-000 000-00

Pièce détachée avec pièces complémentaires (voir parties encadrées sur illustrations).
Par exemple, bague avec vis, barre à aiguille avec vis de fixation d'aiguille, etc.

00-000 000-00

Pièce détachée

A

Version A

B

Version B

C

Version C

4,5

Longueur du point 4,5 mm

N

Longueur du point 6,0 mm

0

Fonction de la sous-classe; pour le numéro de la pièce, voir "Équipement de sous-classes".

0

Appartenance de sous-classe, voir "Équipement de sous-classes".

2

Préciser les repères (points, traits ou chiffres) à la commande.

3

Pièce collée

3/1

Bloqué par Loctite

3/3

Feuille auto-adhésive.

3/11

Appliquer la pâte d'étanchéité epple 22.

4

Préciser la version à la commande.

5

Joindre échantillons de couture ou matières.

6

Préciser la grosseur de l'aiguille et la forme de la pointe à la commande.

7/14

Pour couteau à droite de l'aiguille.

7/15

Pour couteau derrière l'aiguille.

7/16

Pour couteau à gauche de l'aiguille.

7/23

Couteau inférieur à tranchant en métal dur.

8/2

Longueur de coupe; à préciser à la commande.

9

Distance de coupe

9/2

Distance de coupe; à préciser à la commande.

10

Écartement des aiguilles

10/2

Écartement des aiguilles à préciser à la commande.

16/2

Profondeur de crantage; à préciser à la commande.

22

Accessoires

26/10

Pour la limitation de la longueur du point.

27/2

Chiffre entre parenthèses = épaisseur en mm.

27/5

Chiffre entre parenthèses = longueur en mm.

27/12

Chiffre entre parenthèses = diamètre x largeur en mm.

27/17

Chiffre entre parenthèses = épaisseur en mm.

28

Version spéciale

28/5

Commande spéciale

30

Ancienne version, à commander à nouveau pour échange.

30/0

Ne figure plus au programme.

30/1

Ancienne version, nous envoyer pour réparation.

30/2Ancienne version, remplacée par n° 91-168 858-12.**30/3**Ancienne version, remplacée par nouvelle n°. 91-171 283-91 et 91-172 958-91.**30/4**Ancienne version, remplacée par n° 91-171 904-91.**30/5**

Ancienne version, remplacée par n° 91-174 142-11.

30/6

Ancienne version, remplacée par n° 91-028 955-15; 91-100 338-15; 91-174 033-05.

- 30/8** Ancienne version, remplacée par nos **91-171 465-91** et 91-171 744-05 (voir page 33).
- 30/9** Ancienne version, remplacée par n° 15-120 800-05; 91-175 539-05.
- 30/10** Ancienne version, remplacée par nouvelle version n° 91-172 093-11.
- 30/11** Ancienne version, remplacée par n° **91-087 144-91**.
- 30/12** Ancienne version, remplacée par n° **99-134 850-91**.
- 30/13** Ancienne version, remplacée par n° **91-171 462-70/993** (voir page 146).
- 30/18** Ancienne version, remplacée par n° **91-178 019-91** (voir page 169).
- 31** Pièces seules non interchangeables, si nécessaire, commander élément complet (encadré) ou le renvoyer pour réparation.
- 31/1** N'est pas livrable séparément.
- 32** Aucune garantie ne pourra être assurée quant à la précision d'ajustage de cette pièce avec la pièce correspondante; il est indiqué de commander un mécanisme complet.
- 32/1** Retouches nécessaires au montage.
- 35/1** River après montage.
- 38/7** A enduction plastique
- 38/8** Dentée
- 40/1** Remplir de 280-1-120 144; n° de commande, voir page 7.
- 40/2** Imbiber d'huile 280-1-120 144; n° de commande, voir page 7.
- 40/3** Graisser avec de la graisse 280-1-120 247; n° de commande, voir page 7.
- 40/4** Graisser avec de la graisse 280-1-120 243; n° de commande, voir page 7.
- 40/5** Huiler par 280-1-120 144; n° de commande, voir page 7.
- 40/6** Remplir de 280-1-120 217; n° de commande, voir page 7.
- 40/11** Graisser avec de la graisse 280-1-120 239; n° de commande, voir page 7.
- 60** Au choix
- 80/4** Pour tuyau d'un diamètre intérieur de 4 mm.
- 80/6** Pour tuyau d'un diamètre intérieur de 6 mm.
- 81/3** Utilisation en fonction du besoin.
- 90/1** Pour du courant alternatif.
- 90/2** Pour du courant triphasé.
- 90/3** Pour la fixation du moteur.
- 90/4** Uniquement pour du 420 V triphasé.
- 90/7** Réducteur de vitesse débrayable.
- 90/8** En liaison avec la sous-classe -910/.. (n° **71-59 00-0237**).
- 90/9** Pour moteurs avec numéro de modèle à 8 chiffres.
- 90/11** Pour moteurs Stop électroniques
- 90/12** Pour moteurs-transmetteurs
- 90/13** Pour moteurs Stop à levier
- 90/19** Conditionneur d'air comprimé -925/.. requis.
- 90/23** Pour fixer la pièce n° 91-177 464-45 au bâti colonne.
- 90/31** Inverseur du sens de couture nécessaire (voir page 190).
- 90/32** Pour tension de fil n° **91-170 275-91** (voir page 22).
- 90/33** Pour tension de fil n° **91-170 275-91** (voir page 22) au lieu de n° 91-010 183-05.
- 90/34** Pour bâti-tube acier
- 90/35** Pour bâti colonne
- 95/2** Valeur "x" = Longueur de coupe en mm, à préciser à la commande.
- 95/3** Valeur "x" = Grosseur en mm, à préciser à la commande.
- 95/5** Valeur "x" = Ecartement des aiguilles.
- 96** Préciser longueur.
- 96/3** Flexible d'un diamètre intérieur de 3 mm; préciser la longueur.
- 96/4** Flexible d'un diamètre intérieur de 4 mm; préciser la longueur.
- 96/6** Flexible d'un diamètre intérieur de 6 mm; préciser la longueur.
- 96/10** Préciser longueur x largeur
- 96/25** Flexible d'un diamètre intérieur de 2,5 mm; préciser la longueur.

00-000 000-00

Grupo principal de piezas, compuesto de: subgrupo de piezas o subgrupo de piezas y piezas individuales o subgrupo de piezas, piezas individuales y piezas complementarias (véanse los recuadros en las páginas ilustradas).

00-000 000-00

Subgrupo de piezas, compuesto de: piezas individuales o piezas individuales y piezas complementarias (véanse los recuadros en las páginas ilustradas).

00-000 000-00

Pieza individual con pieza complementaria (véanse los recuadros en las páginas ilustradas).
Por ejemplo: anillo de ajuste con tornillo, barra de aguja con tornillo de fijación para la aguja, etc.

00-000 000-00

Pieza individual

A

Tipo A

B

Tipo B

C

Tipo C

4,5

Largo de puntada 4,5 mm

N

Largo de puntada 6,0 mm

Dependientes de la subclase, para el Nº de pieza véase "Composición de las subclases".

0

Para saber a qué subclase pertenece, véase "Composición de las subclases".

2

Señales (puntos, rayas o cifras), indiquense en los pedidos.

3

Pieza pegada

3/1

Asegurado con Loctite

3/3

Hoja autoadhesiva

3/11

Aplíquese la pasta para juntas epple 22

4

Indíquese el tipo en los pedidos.

5

Enviense muestras de costura.

6

Grosor de aguja y forma de la punta, indiquense en los pedidos.

7/14

Para cuchilla a la derecha de la aguja.

7/15

Para cuchilla en el centro de la aguja.

7/16

Para cuchilla a la izquierda de la aguja.

7/23

Cuchilla inferior con hilo de metal duro.

8/2

Largura de corte, indiquense en los pedidos.

9

Margen de corte

9/2

Margen de corte, indiquense en los pedidos.

10

Distancia entre agujas.

10/2

Indíquese en los pedidos la distancia entre agujas.

16/2

Profundidad de dentado, indiquense en los pedidos.

22

Accesorios

26/10

Para la limitación de largo de puntada.

27/2

Cifra entre paréntesis = espesor en mm.

27/5

Cifra entre paréntesis = largura en mm.

27/12

Cifra entre paréntesis = diámetro x anchura en mm.

27/17

Cifra entre paréntesis = espesor en mm.

28

Tipo especial

28/5

Pedido especial

30

Tipo anterior, en caso de sustitución pídase de nuevo.

30/0

Fuera de programa.

30/1

Tipo anterior, envíenos para su reparación.

30/2

Tipo anterior, se sustituye por el Nº 91-168 858-12.

30/3

Tipo anterior, se sustituye por el nuevo tipo Nºs 91-171 283-91 y 91-172 958-91.

30/4

Tipo anterior, se sustituye por el Nº 91-171 904-91.

30/5

Tipo anterior, se sustituye por el Nº 91-174 142-11.

30/6

Tipo anterior, se sustituye por el Nº 91-028 955-15; 91-100 338-15; 91-174 033-05.

30/8

Tipo anterior, se sustituye por los Nºs 91-171 465-91 y 91-171 744-05, (véase la página 33).

- 30/9** Tipo anterior, se sustituye por el N° 15-120 800-05; 91-175 539-05.
- 30/10** Tipo anterior, se sustituye por el nuevo tipo N° 91-172 093-11.
- 30/11** Tipo anterior, se sustituye por los N° 91-087 144-91.
- 30/12** Tipo anterior, se sustituye por el N° 99-134 850-91.
- 30/13** Tipo anterior, se sustituye por el N° 91-171 462-70/993 (véase la página 146).
- 30/18** Tipo anterior, se sustituye por el N° 91-178 019-91 (véase la página 169).
- 31** No es recambiable individualmente, en caso de sustitución pídase el agregado completo (pieza enmarcada), o envíese para su reparación.
- 31/1** No puede suministrarse por separado.
- 32** Al montar esta pieza no se asume garantía alguna en cuanto a la tolerancia y precisión de ajuste respecto a la pieza correspondiente; por esta razón se recomienda pedir el grupo completo.
- 32/1** Al montar esta pieza hay que retocarla antes.
- 35/1** Remáchese después del montaje.
- 38/7** Con revestimiento de plástico.
- 38/8** Dentado
- 40/1** Rellene con 280-1-120 144; para el N° de pedido véase la página 7.
- 40/2** Empape con aceite 280-1-120 144; para el N° de pedido véase la página 7.
- 40/3** Engrase con grasa 280-1-120 247; para el N° de pedido véase la página 7.
- 40/4** Engrase con grasa 280-1-120 243; para el N° de pedido véase la página 7.
- 40/5** Lubrifique con 280-1-120 144; para el N° de pedido véase la página 7.
- 40/6** Rellene con 280-1-120 217; para el N° de pedido véase la página 7.
- 40/11** Engrase con grasa 280-1-120 239; para el N° de pedido véase la página 7.
- 60** Opcional
- 80/4** Para tubo de plástico de 4 mm diámetro interior.
- 80/6** Para tubo de plástico de 6 mm diámetro interior.
- 81/3** Utilización, según sea necesario.
- 90/1** Para corriente alterna monofásica.
- 90/2** Para corriente alterna trifásica.
- 90/3** Para fijación del motor.
- 90/4** Para usar solamente con c. a. trifásica de 420 V.
- 90/7** Dispositivo para costura lenta, desconectable.
- 90/8** En combinación con la subclase -910/.. N° 71-59 00-0237.
- 90/9** Para motores con número de modelo de 8 cifras.
- 90/11** Para motores stop electrónicos.
- 90/12** Para motores de embrague
- 90/13** Para motores stop de palanca
- 90/19** Requiere grupo acondicionador del aire comprimido -925/..
- 90/23** Para asegurar la pieza N° 91-177 464-45 a la bancada de columna.
- 90/31** Requiere el dispositivo para inversión de costura (véase la página 190).
- 90/32** Para tensión de hilo N° 91-170 275-91 (véase la página 22).
- 90/33** Para el tensahilos N° 91-170 275-91 (véase la pág. 22), en lugar del N° 91-010 183-05.
- 90/34** Para bancada de chapa perfilada.
- 90/35** Para bancada de columna.
- 95/2** Valor x = Largura de corte en mm, indíquese en los pedidos.
- 95/3** Valor x = Grosor en mm, indíquese en los pedidos.
- 95/5** Valor x = Distancia entre agujas.
- 96** Indíquese la largura.
- 96/3** Tubo flexible de 3 mm de diámetro interior; indíquese la largura en los pedidos.
- 96/4** Tubo flexible de 4 mm de diámetro interior; indíquese la largura en los pedidos.
- 96/6** Tubo flexible de 6 mm de diámetro interior; indíquese la largura en los pedidos.
- 96/10** Indíquese largura x anchura
- 96/25** Tubo flexible de 2,5 mm de diámetro interior; indíquese la largura en los pedidos.

Unterklassenabhängige Teile (Nähwerkzeuge) siehe Unterklassen-Ausstattung

Subclass-dependent parts (gauge parts), see "Equipment of subclasses"

Pour les pièces (organes de couture) fonction des ss.-cl., voir "Équipement des sous-classes"

Para las piezas (órganos de costura) dependientes de la subclase véase "Composición de las Subclases"

Teilebenennung Nomenclature Désignation de la pièce Denominación de la pieza	Bestellnummer Ordering number N° de c ^{de} N° de pedido	Unterklasse Subclass Sous-classe Subclase	Abgebildet auf Seite: See page: Voir page: Ilustrada en la pág.:
* Nadeln System Needle system Aiguille système Agujas sistema	Nadelsystem-Tabelle, siehe Seite 188 Table of Needle system, see page 188 Tableau des systèmes d'aiguilles, voir page 188 Tabla de sistema de agujas, véase la página 188		
* Nadelbefestigungsschraube Needle set screw Vis de fixation de l'aiguille Tornillo de sujeción de la aguja	11-174 173-15 11-330 082-15 11-330 085-15	-818/56	19 75 19, 36, 39, 44, 59, 64, 68, 74, 79, 88, 148
Klemmschraube zur Nadelstange Needle bar clamp screw Vis de serrage pour la barre à aiguille Tornillo de sujeción para la barra de aguja	11-174 173-15		19
* Fadenhebel vollst. / Take-up lever, compl. Releveur de fil cpt. / Palanca tirahilos completa	91-172 029-12		19
Nadelstangenschwinge Needle bar frame Cadre de barre à aiguille Balancin de la barra de aguja	91-174 276-05		18
Gelenkbolzen Hinge stud Boulon d'articulation Perno articulado	91-174 016-05		18
Fadenführung Thread guide Guide-fil Guiahilos	91-084 446-15 91-169 594-15 91-169 670-15 91-169 672-15 91-169 679-15 91-169 745-91 91-170 408-15 91-170 423-15 91-170 462-25 91-170 996-15 91-172 123-15 91-172 242-91 91-172 380-15	-814/06-61/05-960/61	171 22, 23, 40, 41, 73, 116 24 24 22, 23, 40, 41, 66, 68, 99 24 47 58 73 72 70 19 47, 191
Spannungsscheibe / Tension disc Disque de tension / Platillo tensor	91-002 065-05		22, 23, 40, 41, 47, 66, 68, 73, 99, 116, 191
Spannungsbolzen Stud for thread tension Boulon de tension de fil Pasador para tensahilos	91-169 548-05 ^[35/1] 91-169 567-05 ^[3/1]		22, 23, 40, 41, 66, 68, 73, 99 22, 23, 40, 41, 47, 73, 116, 191
Flachzahnriemen Driving belt with flat cleats Courroie dentée plate Correa dentada plana	16-409 907-05 16-410 079-05 91-168 244-04 ^[2] 91-171 580-05	-748/56 -748/56 -749/01	100 102 24 60
* Kettenstichgreifer Chainstitch looper Boucleur Garfio para punto cadeneta	Teilenummer siehe Unterklassen-Ausstattung For part number see Subclass Listing N° de pièce, voir dotation des sous-classes Para el N° de pieza véase "Composición de las Subclases"		
* Befestigungsschraube zum Greifer Fastening screw for hook Vis de fixation du crochet Tornillo para fijación del garfio	11-108 177-15 11-317 217-15 11-317 950-15	-818/56 -704/02	30, 43, 49, 59, 66, 69, 75 75 43
Distanzscheibe zum Kettenstichgreifer Washer of chain stitch looper Rondelle d'écartement pour le boucleur Disco distanciador para el garfio de punto cadeneta	91-169 614-05 91-169 615-05 91-170 693-05 91-170 694-05		30, 43, 75
* Befestigungsschraube zum Stoffschieber Fastening screw for feed dog Vis de fixation de griffe Tornillo para fijación del transportador	91-000 407-15		30, 42, 44

Unterklassenabhängige Teile (Nähwerkzeuge) siehe Unterklassen-Ausstattung

Subclass-dependent parts (gauge parts), see "Equipment of subclasses"

Pour les pièces (organes de couture) fonction des ss.-cl., voir "Équipement des sous-classes"

Para las piezas (órganos de costura) dependientes de la subclase véase "Composición de las Subclases"

Teilebenennung Nomenclature Désignation de la pièce Denominación de la pieza	Bestellnummer Ordering number N° de c ^{de} Nº de pedido	Unterklasse Subclass Sous-classe Subclase	Abgebildet auf Seite: See page: Voir page: Ilustrada en la pág.:
* Befestigungsschraube zur Stichplatte Fastening screw for needle plate Vis de fixation de plaque à aiguille Tornillo para fijación de la placa de aguja	11-108 168-15	-749/01	59
	91-100 296-25		30, 42, 44, 59, 149, 157
	91-082 376-05	-960/81; -960/82; -960/84	166
	91-082 889-05	-960/81; -960/82; -960/84	176, 177
	91-084 063-05	-960/20; -960/21; -960/22; -960/24	156
	91-158 353-01	-960/11	149
* Messer Knife Couteau Cuchilla	91-169 395-04	-731/..	81, 83, 85, 185
	91-170 416-05	-733/..	91, 185
	91-170 440-05	-733/..	91, 93, 95, 185
	91-170 560-04	-731/..	81, 83, 85, 185
	91-172 358-05	-731/..; -900/..	79, 104, 110, 111, 116b
	91-176 537-01 ^{7/23}	-733/..	91
	91-176 597-01 ^{7/23}	-733/..	91, 185
	91-177 152-05	-960/11; -960/14	151
	91-178 043-05	-960/11	150
	91-178 090-05	-900/71	116b
	11-108 093-15	-960/11	149
* Befestigungsschraube zum Messer Fastening screw for knife Vis de fixation du couteau Tornillo para fijación de la cuchilla	11-108 168-15	-960/11; -960/14	151
	11-108 180-15	-960/11	150
	11-174 089-15	-960/20; -960/21; -960/22; -960/24	156
	11-210 076-15	-960/81; -960/82; -960/84	176, 177
	91-700 226-15		79, 104, 110, 111, 116b
Fadenfänger / Thread catcher Attrape-fil / Cazahilos	91-172 131-01	-900/..	104, 110, 114
	91-178 026-01	-814/02-900/71	116
Sprungschalter Micro switch Fin de course Interruptor de final	71-12 00-0025		44, 45, 46, 130, 132, 133, 141, 159, 171, 172
	71-12 00-0575	-910/04	122
	71-12 00-0576	-900/11; -910/04	109, 122
	71-12 00-0577	-910/01	120
* Kohlebürste H46 / Carbon brush H46 Balai de charbon H46 / Escobilla H46	71-23 00-0118	-900/11	109
	71-59 00-0333	-910/01	120
Magnet / Solenoid Electro-aimant / Electroimán	71-17 00-0068	-900/..	105, 112
	71-17 00-0125	-911/03	51
	70-15 21-1102	-900/51	113
	70-15 21-4001	-960/22; -960/62	162, 174
* Schmelzeinsatz Fuse insert Fusible Fusible	70-15 21-4601	-960/22; -960/62	162, 174
	70-15 21-5001	-960/22; -960/62	161, 173
	70-15 21-5203	-900/..	108
	70-15 21-5403	-900/..	106, 107
	70-15 24-0016	-911/03	53
	71-25 00-0267	-960/22; -960/62	162, 174
Endtaster / Limit switch Fin de course / Interruptor de final	71-13 00-0104	-900/..	105, 112
	91-169 715-92	-814/06	69
Fadenzieher Thread puller Tire-fil Tirahilos	91-169 814-92		31, 37, 43, 49, 65, 67, 77, 78
	91-170 149-05		48, 190
	91-170 379-05	-818/..	70
	91-170 428-92	-749/01	58
	91-176 986-92	-704/02; -818/56	43, 75
Befestigungsschraube zum Fadenzieher Fastening screw for thread puller Vis de fixation du tire-fil Tornillo para fijación de la palanca tirahilos	11-108 171-15		48, 190
	11-108 174-15		31, 37, 43, 49, 58, 65, 67, 75, 77, 78
	11-108 177-15	-814/06	69
* Rolle Roller Galet Rodillo	91-170 122-05	-900/..	105, 112, 115

1

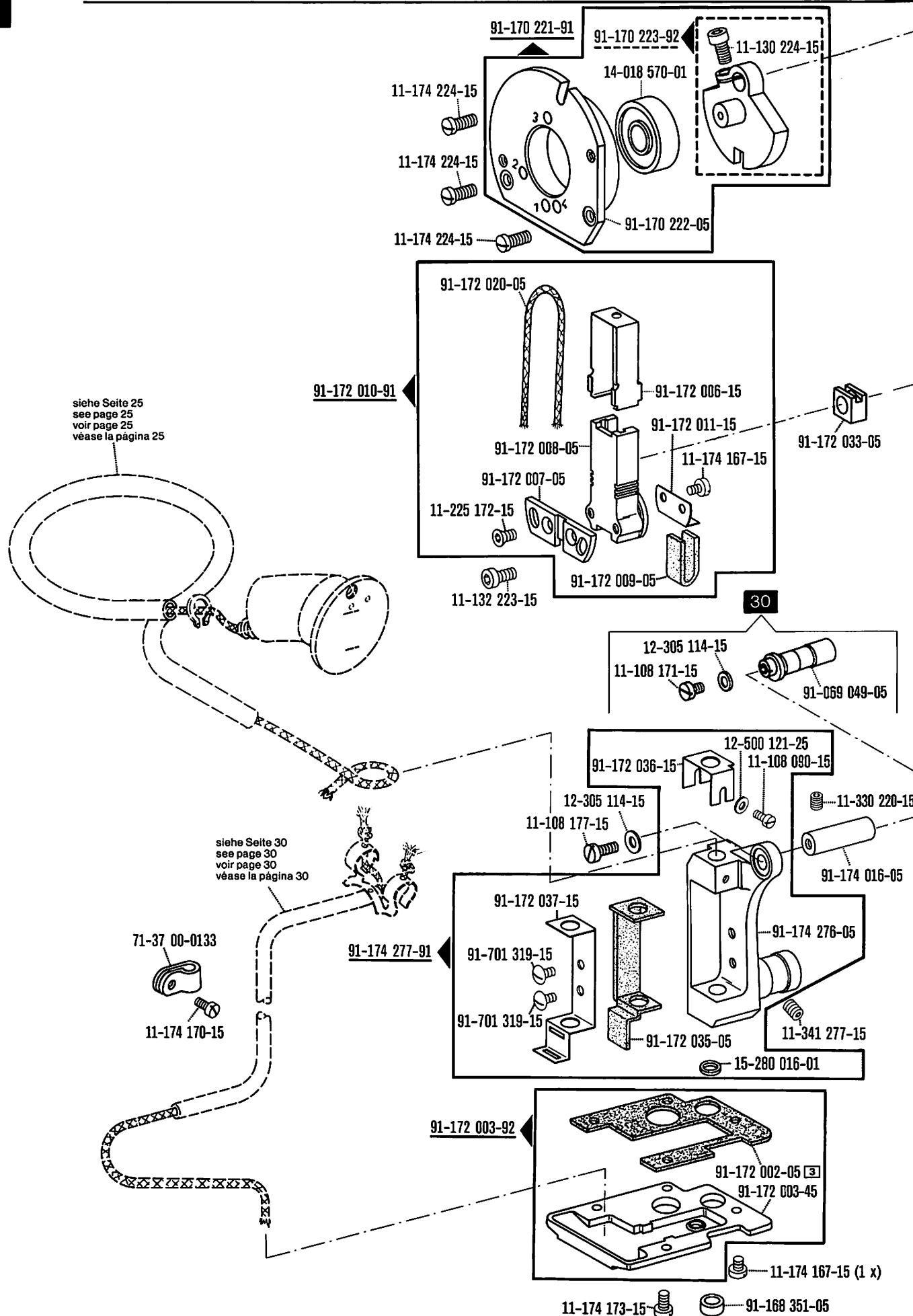

siehe Seite 25
 see page 25
 voir page 25
 véase la página 25

siehe Seite 30
 see page 30
 voir page 30
 véase la página 30

30

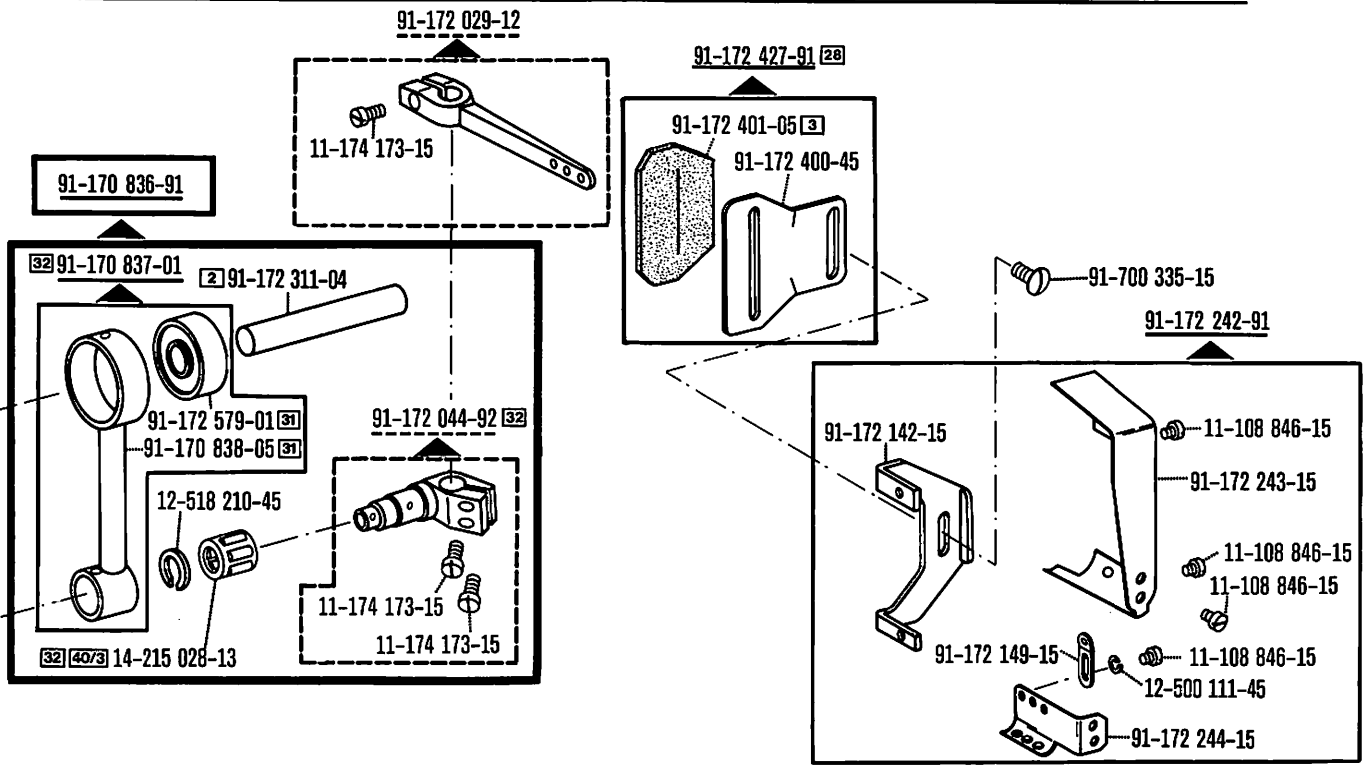

Einnadel · Single-needle
 Une aiguille · Aguja única

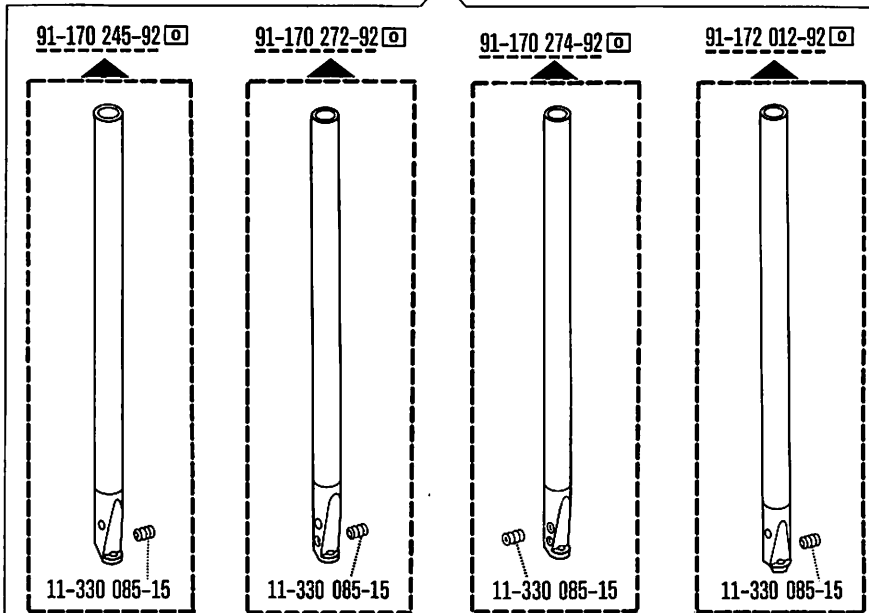

Zweinnadel · Two-needle
 Deux aiguilles · Dos agujas

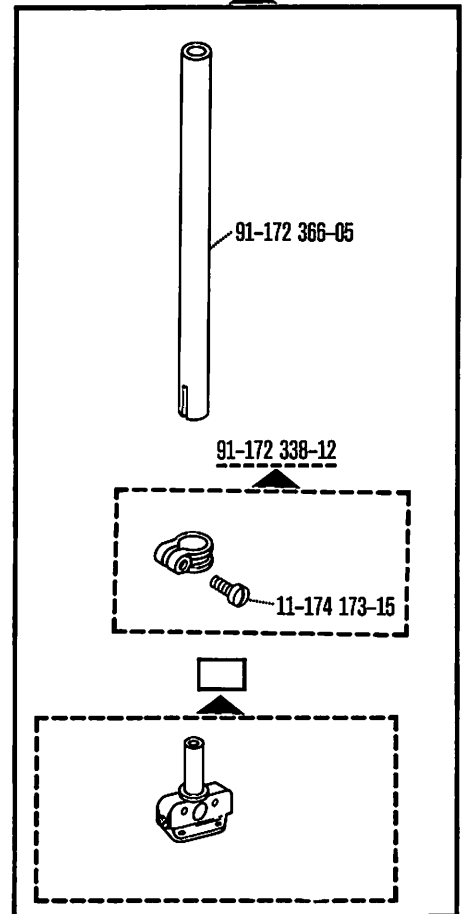

30

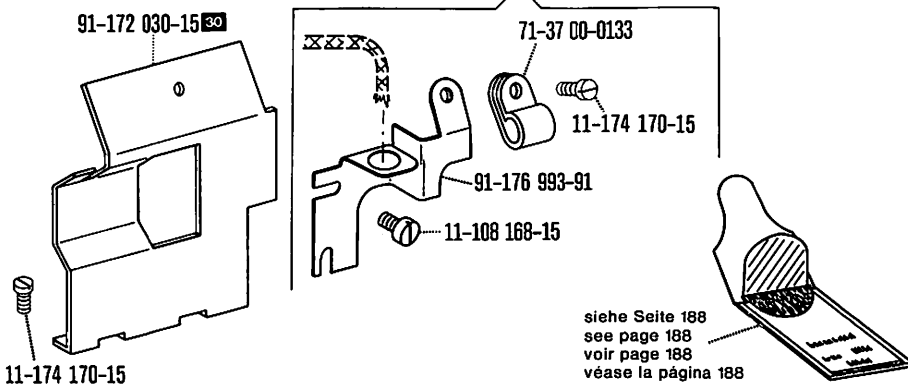

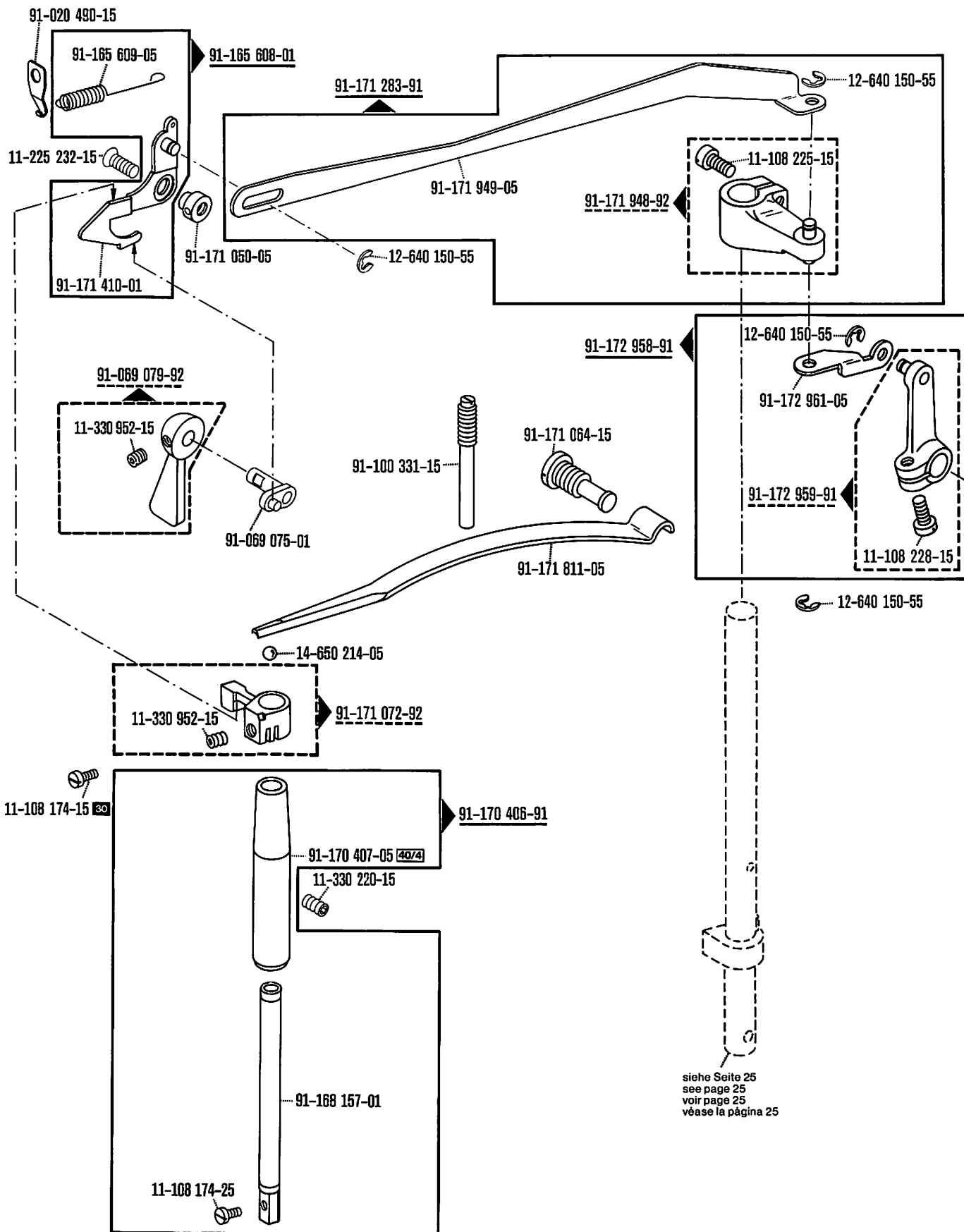

siehe Seite 25
 see page 25
 voir page 25
 véase la página 25

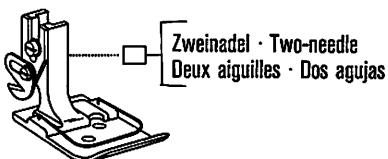
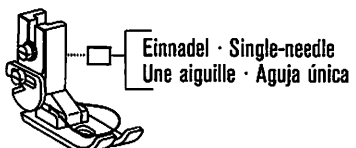

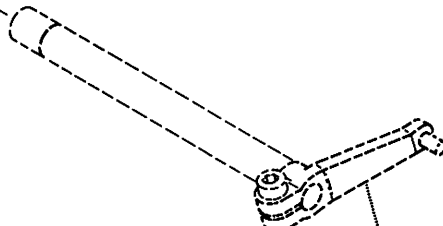
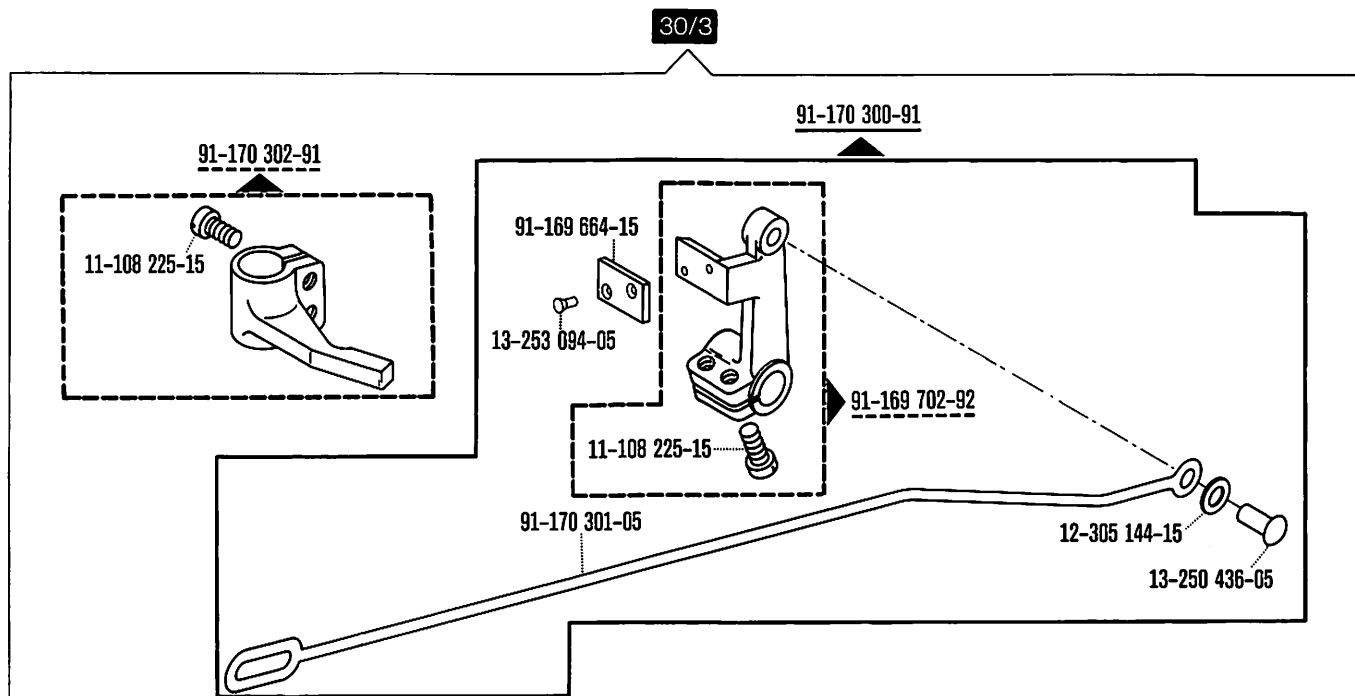

siehe Seite 22
 see page 22
 voir page 22
 véase la página 22

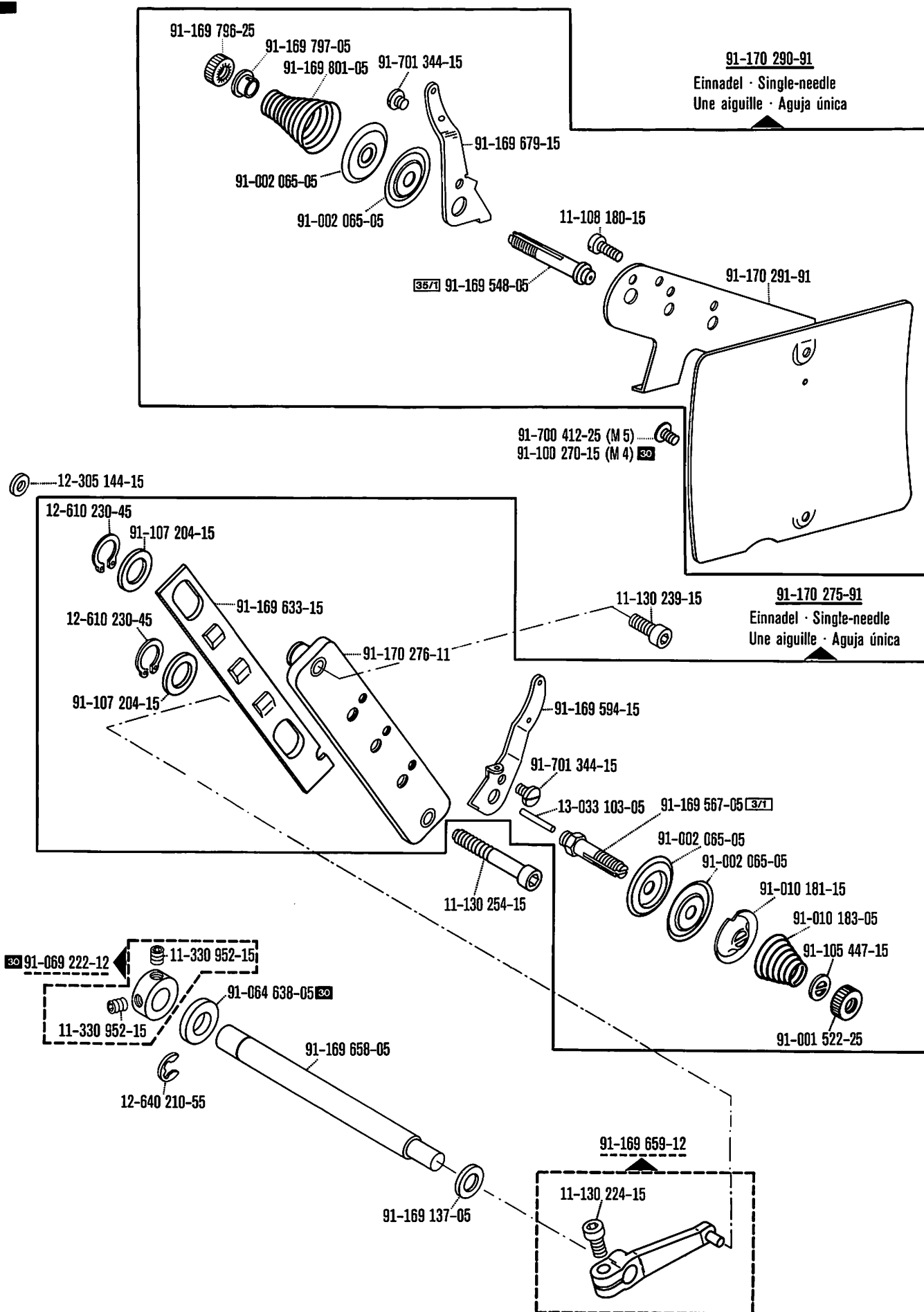

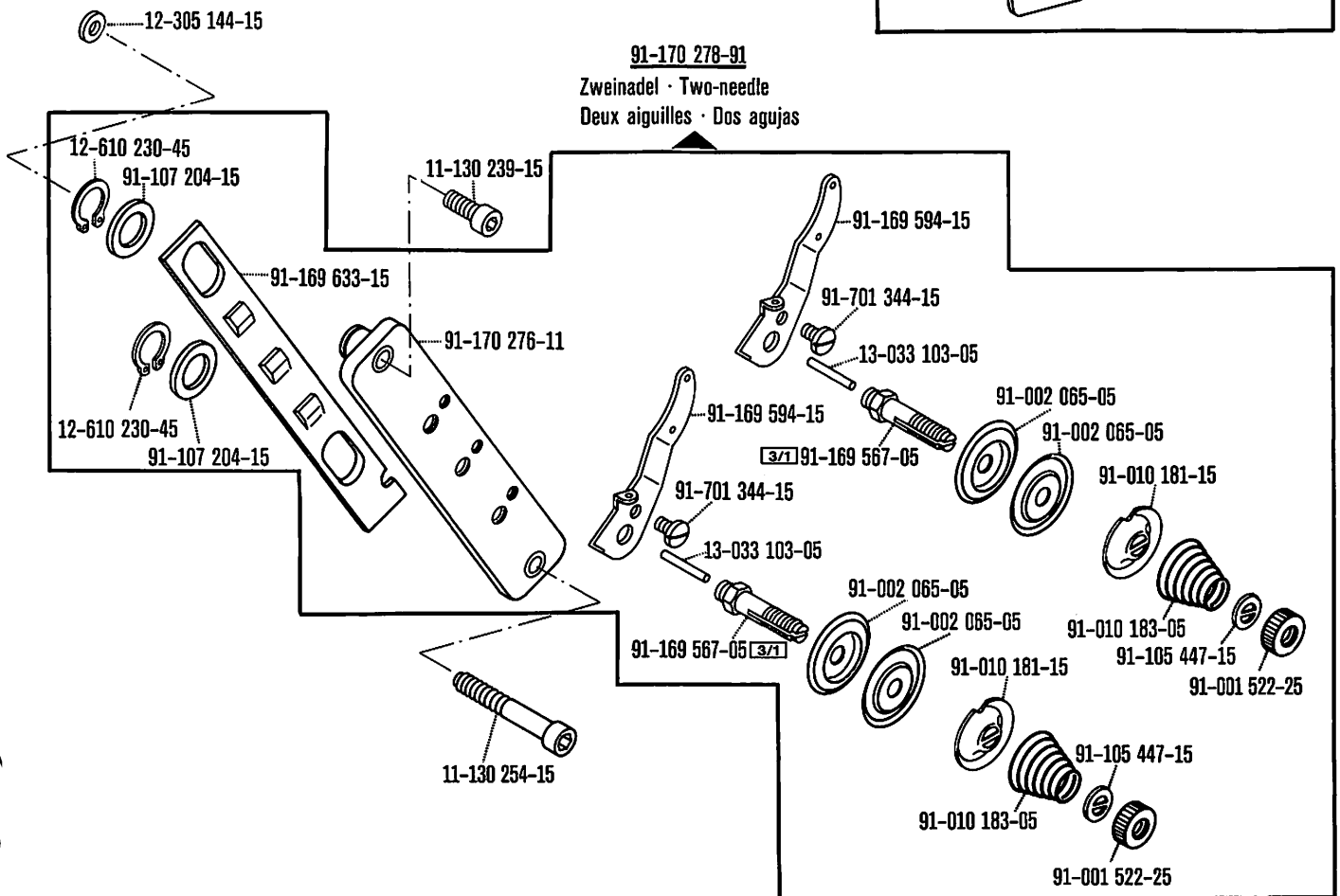
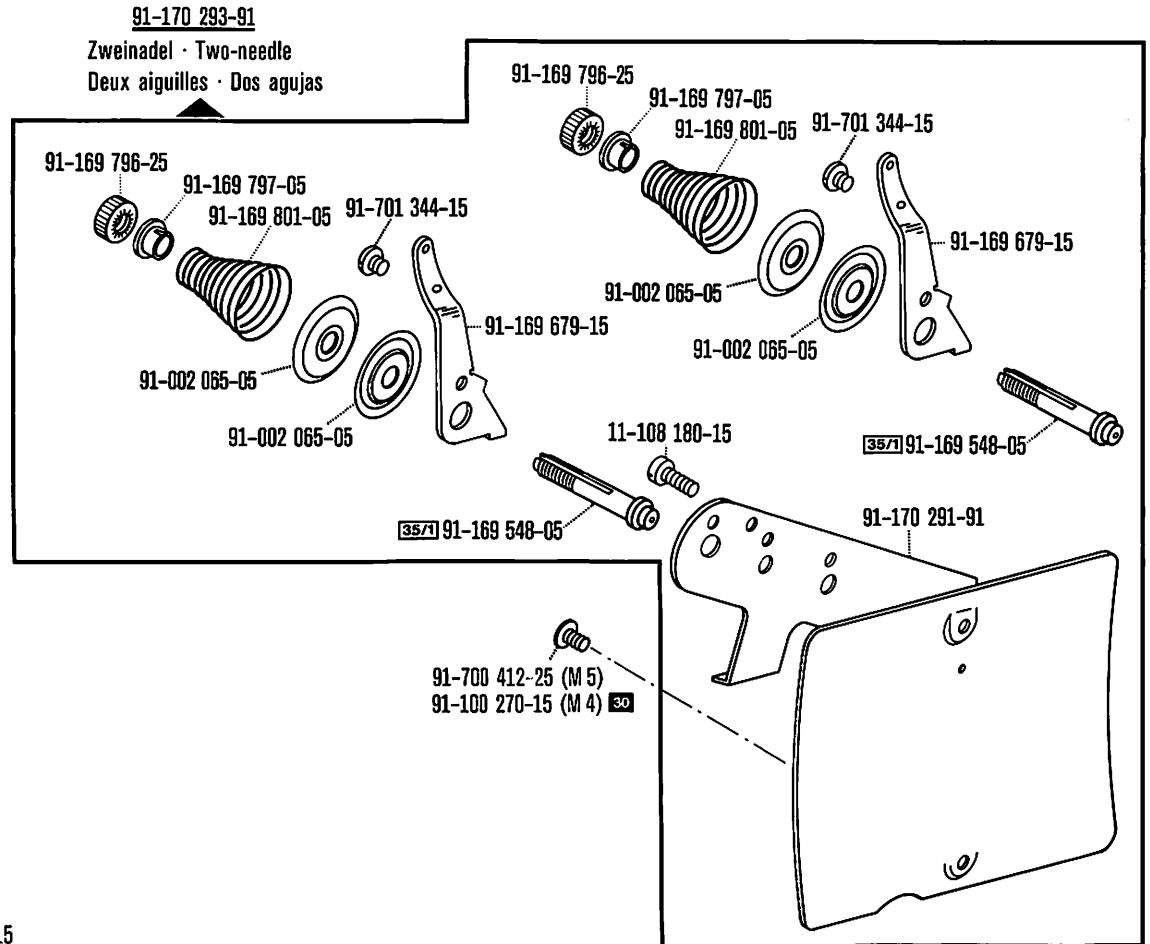

2

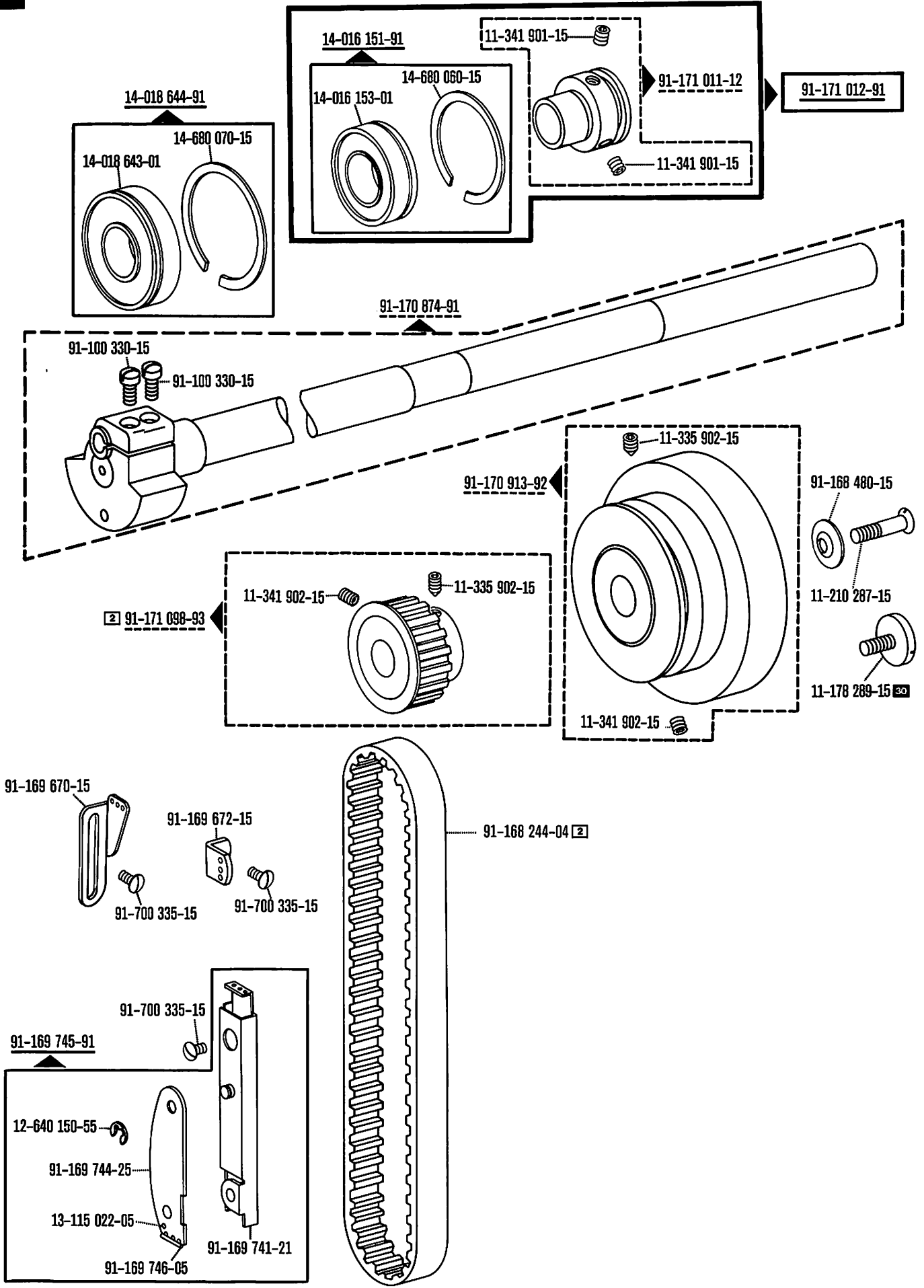

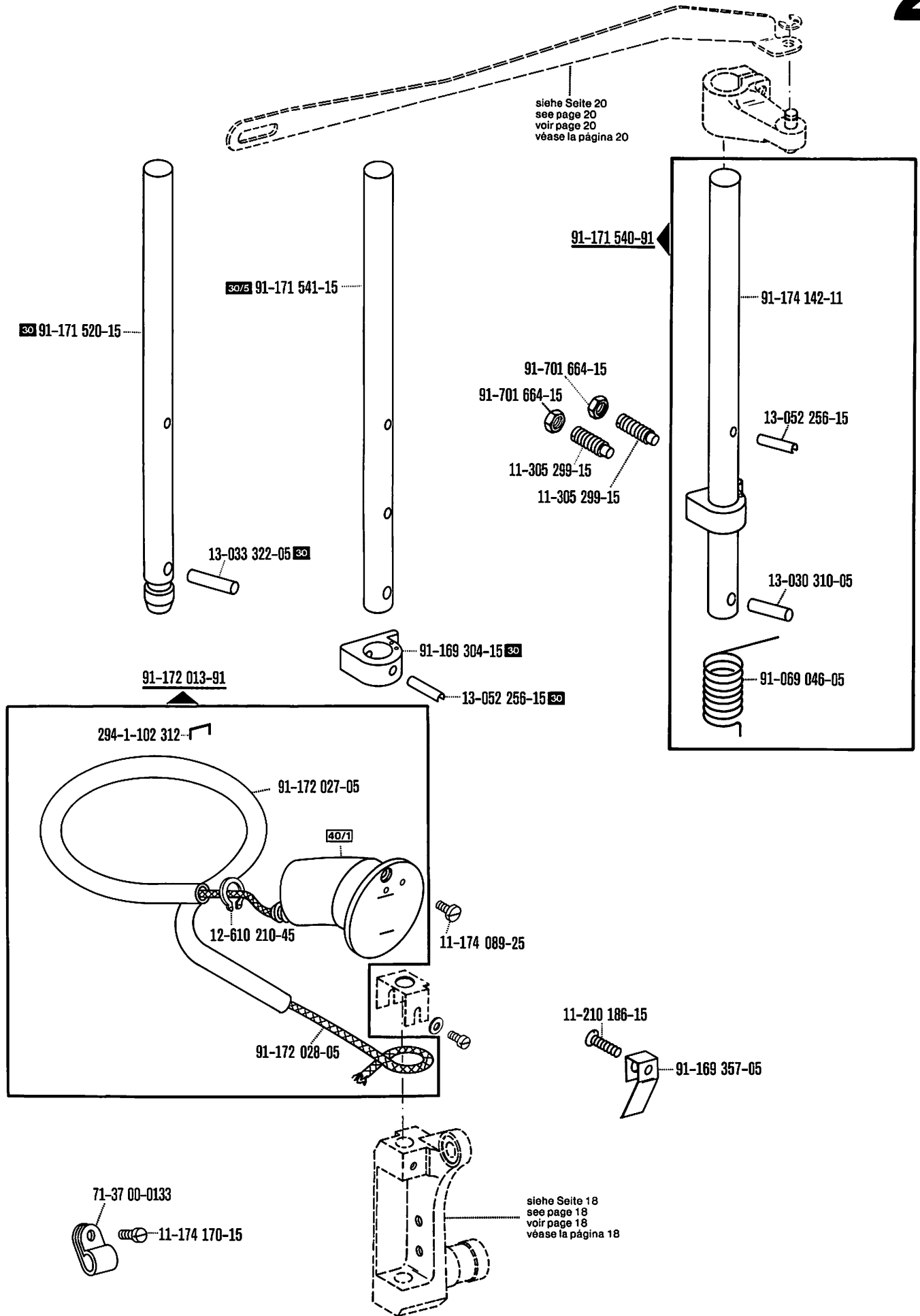

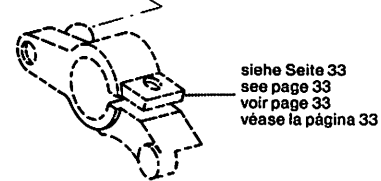
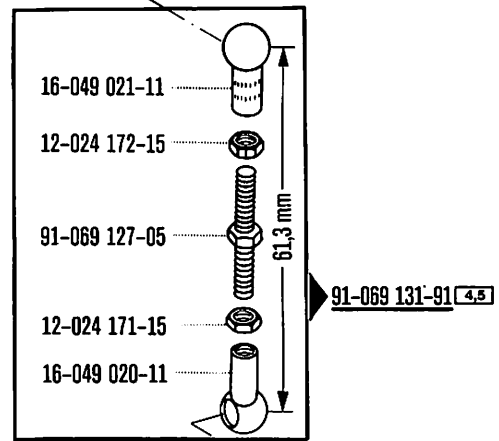
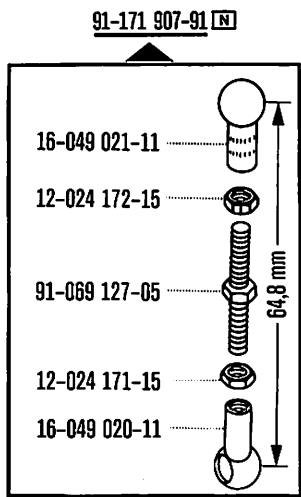
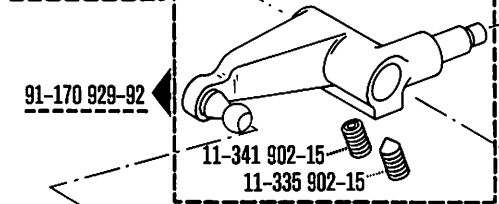
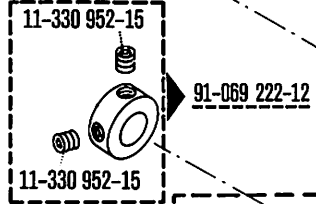
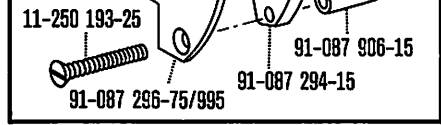
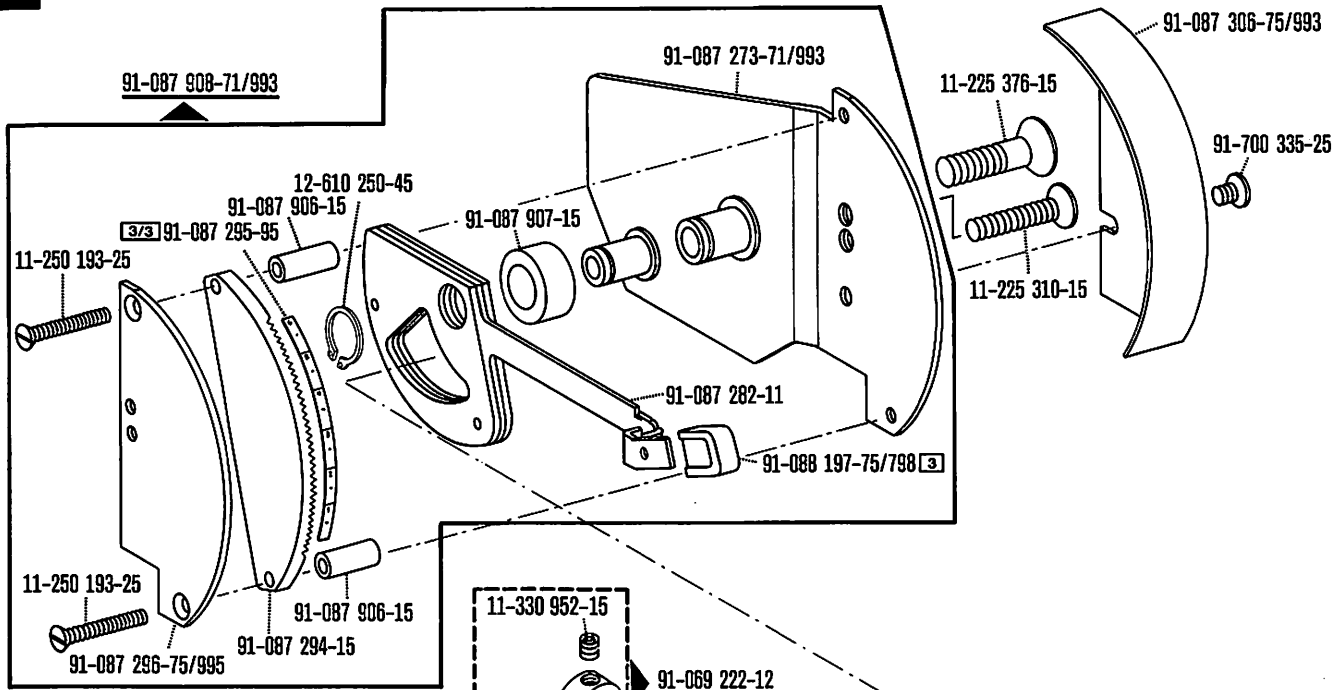

siehe Seite 33
 see page 33
 voir page 33
 véase la página 33

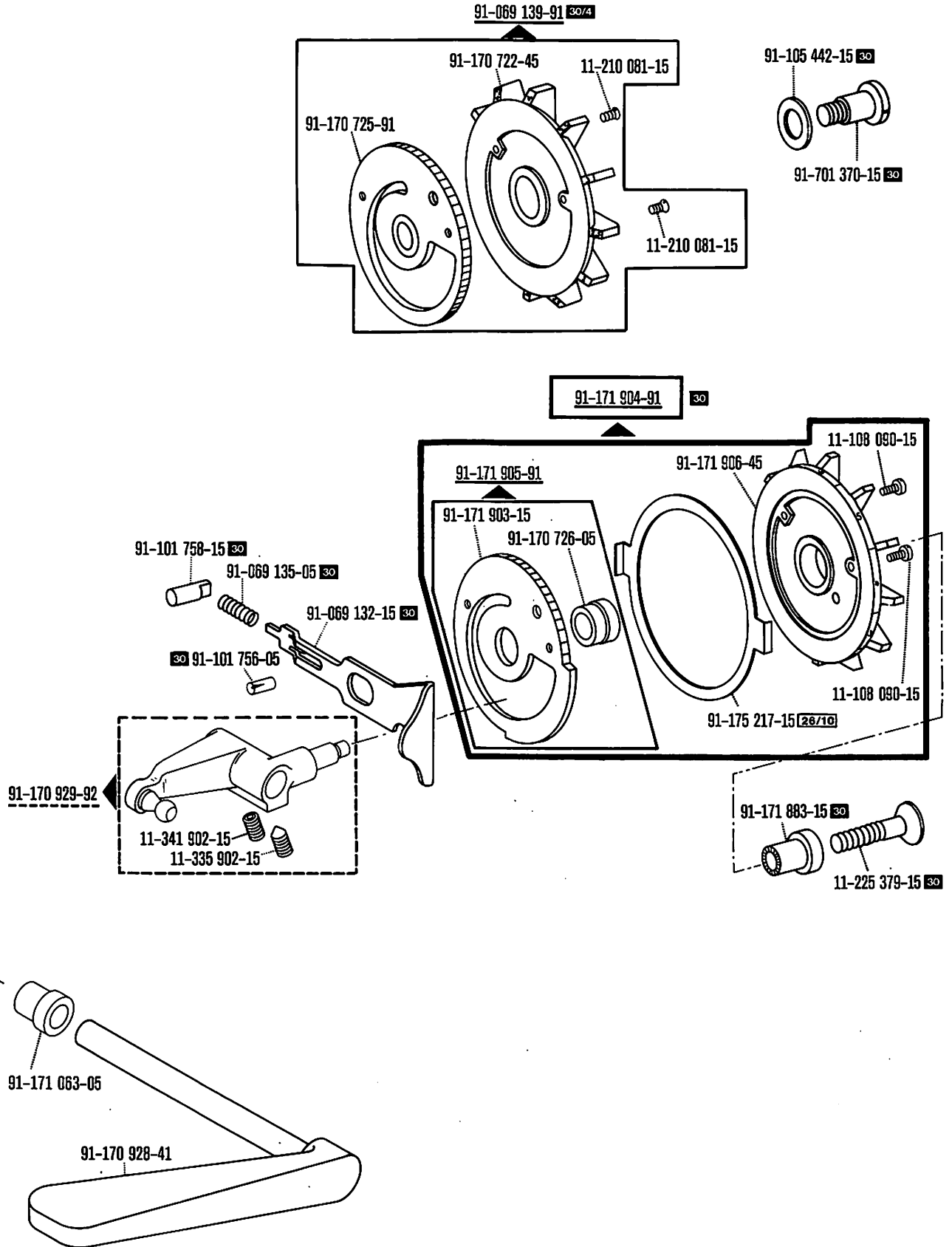

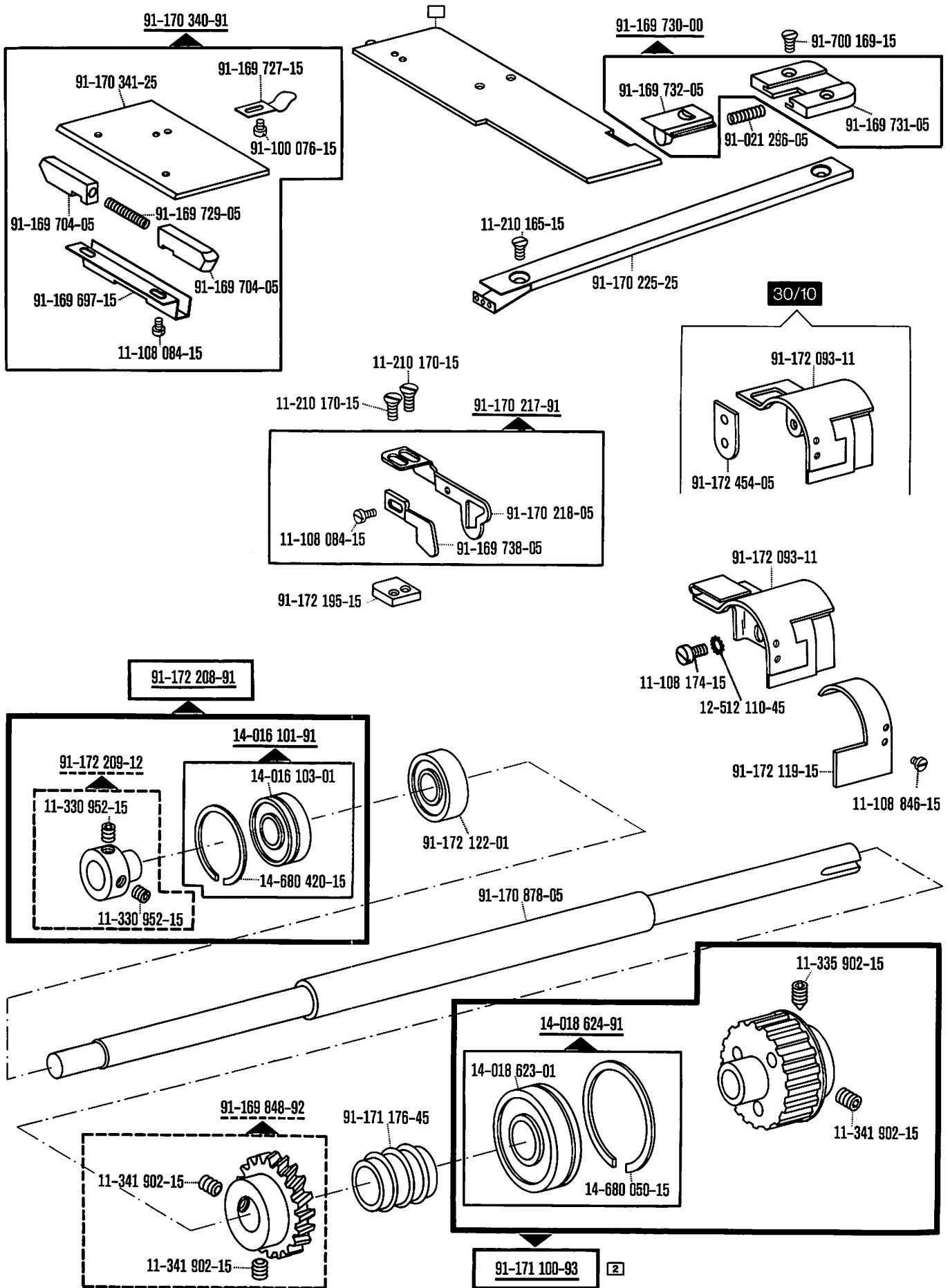

30

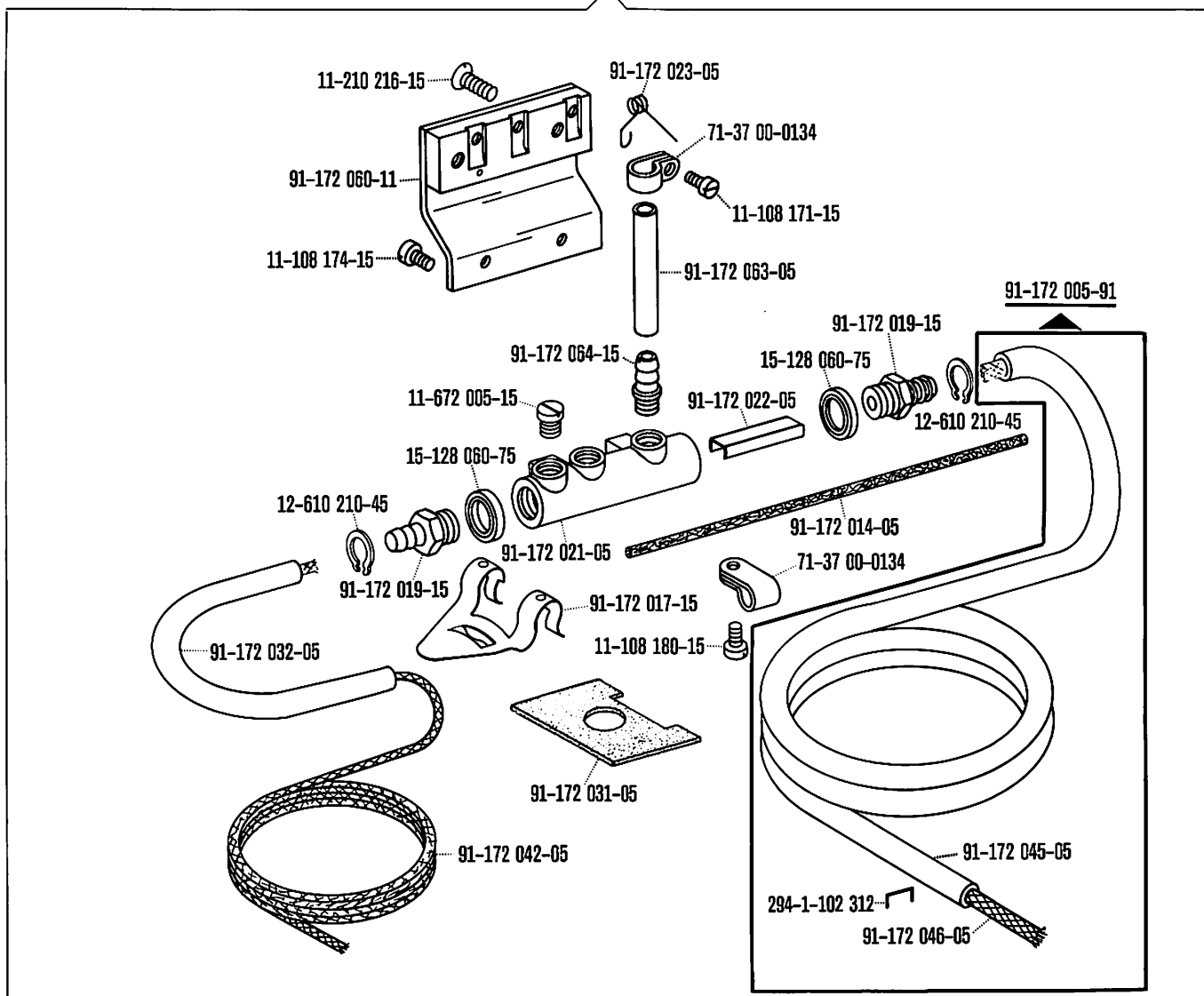

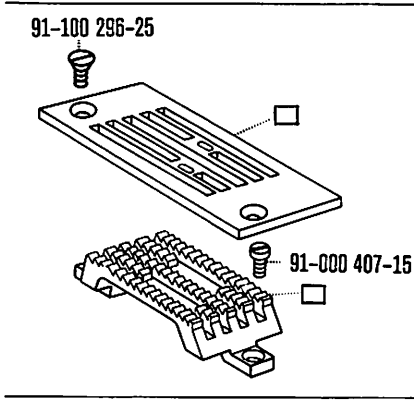

Zweinadel
Two-needle
Deux aiguilles
Dos agujas

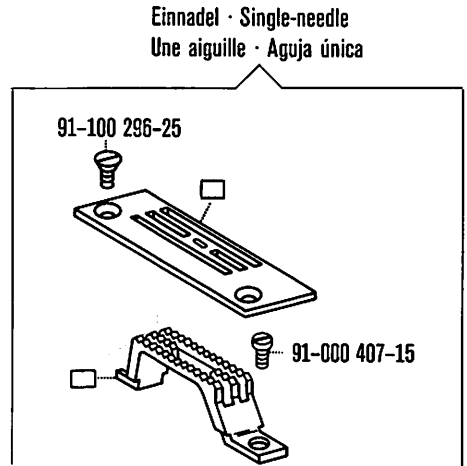

Einnadel · Single-needle
Une aiguille · Aguja única

Zweinadel · Two-needle
Deux aiguilles · Dos agujas

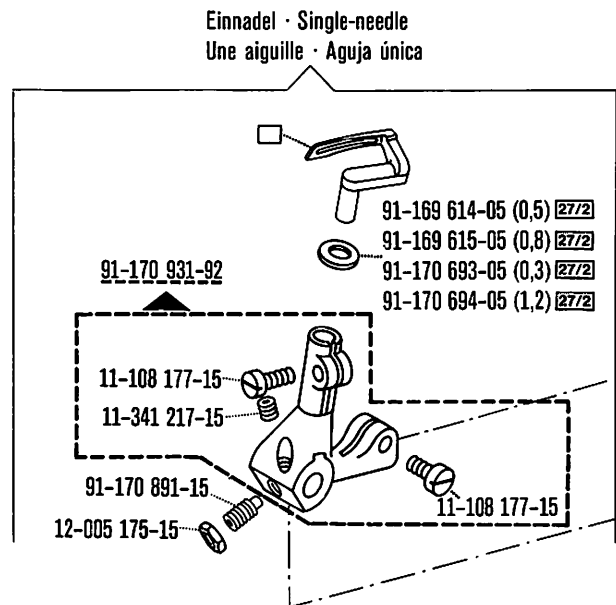
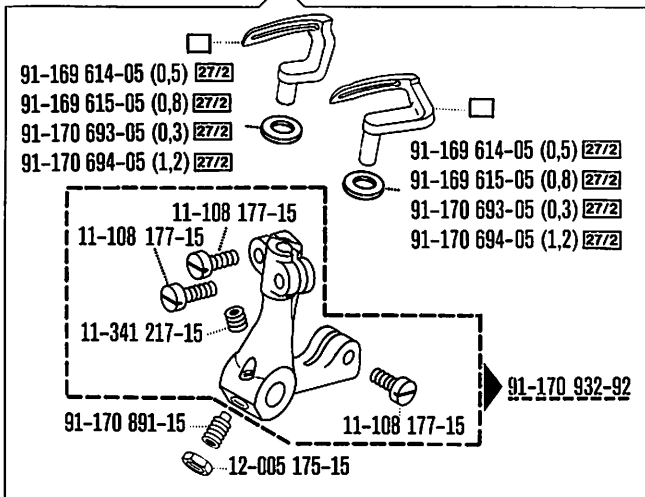

Einnadel · Single-needle
Une aiguille · Aguja única

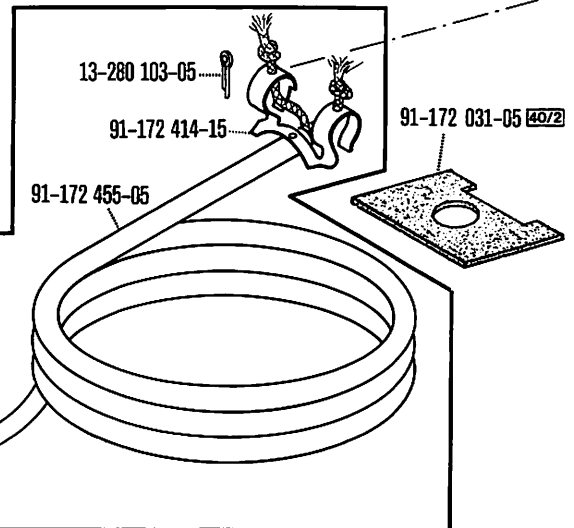
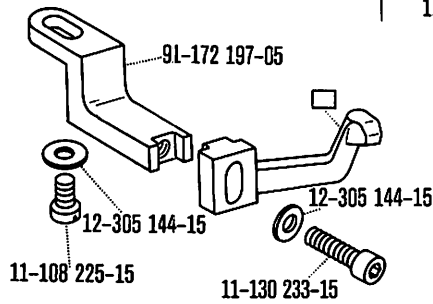

91-172 417-91

40/2 91-172 456-05

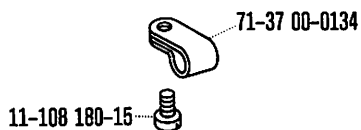

siehe Seite 18
see page 18
voir page 18
véase la página 18

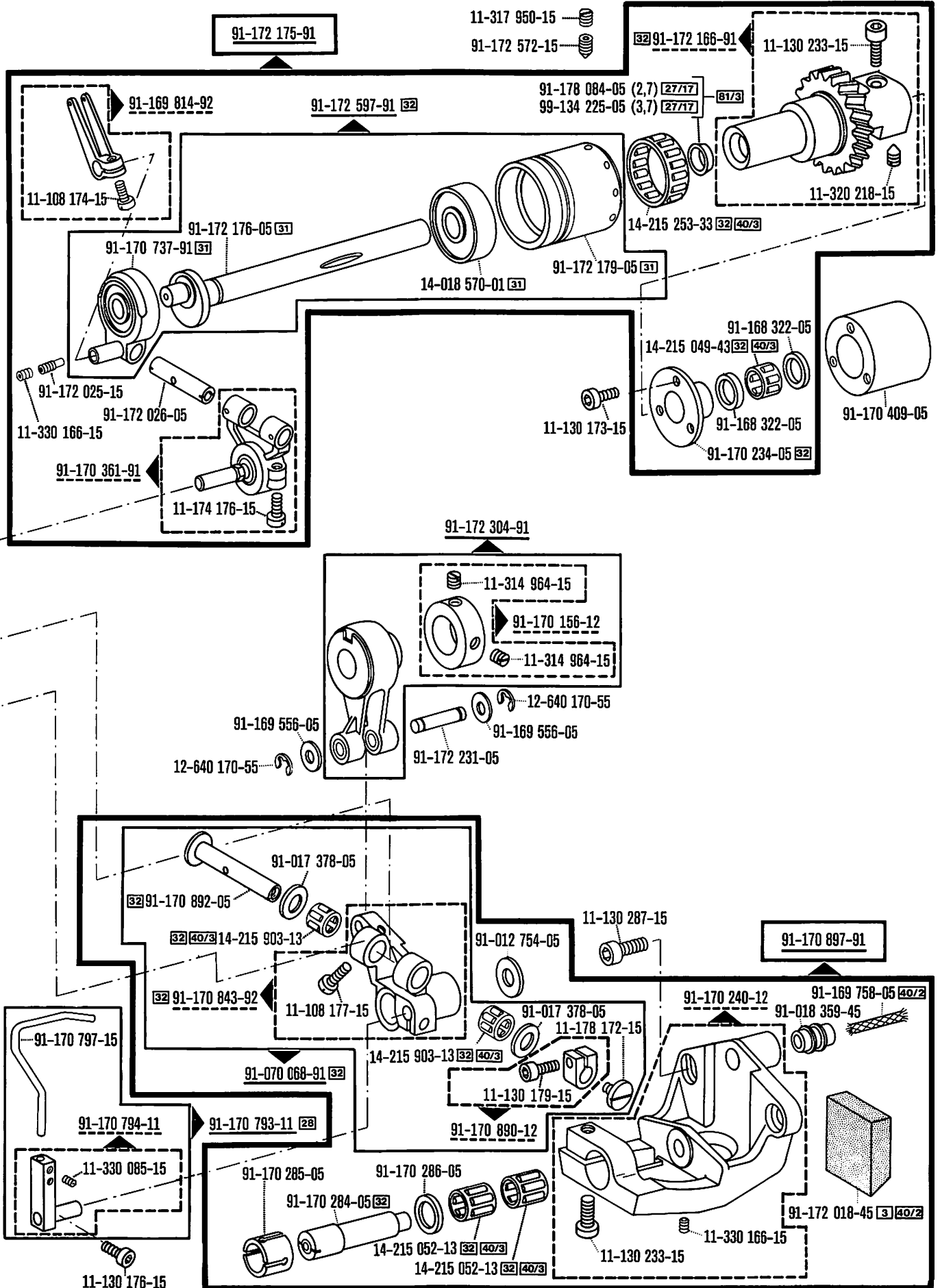

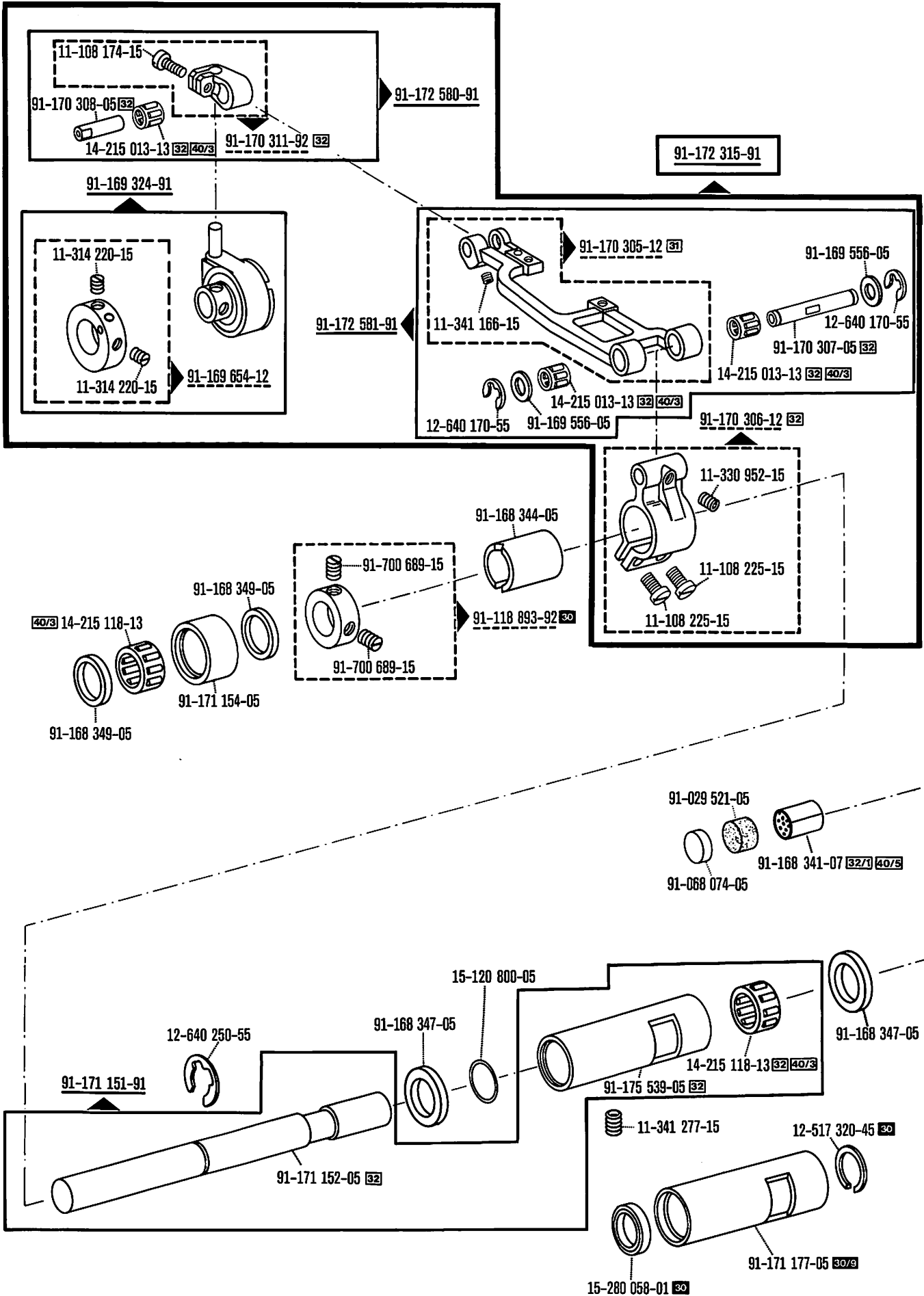

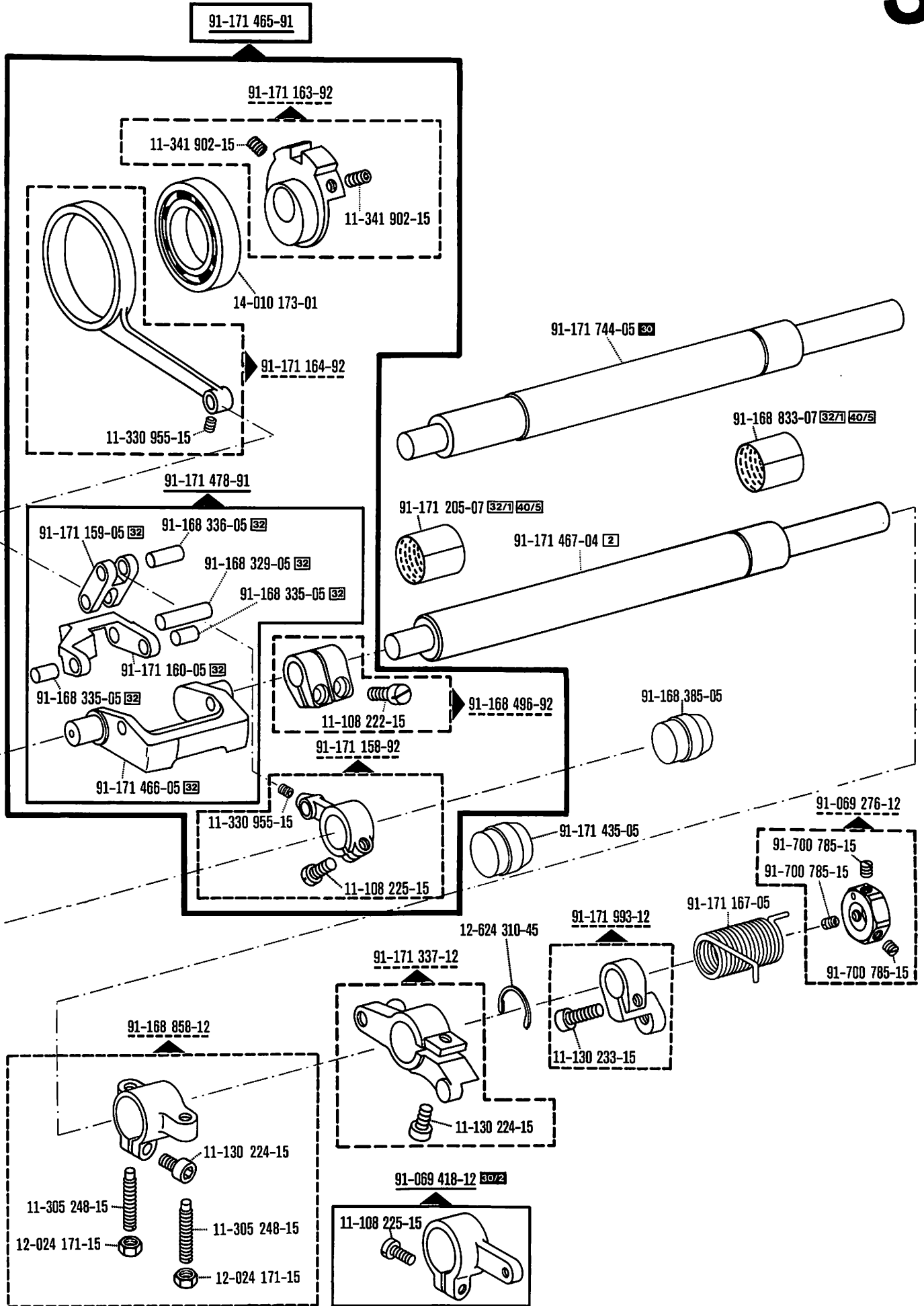

3

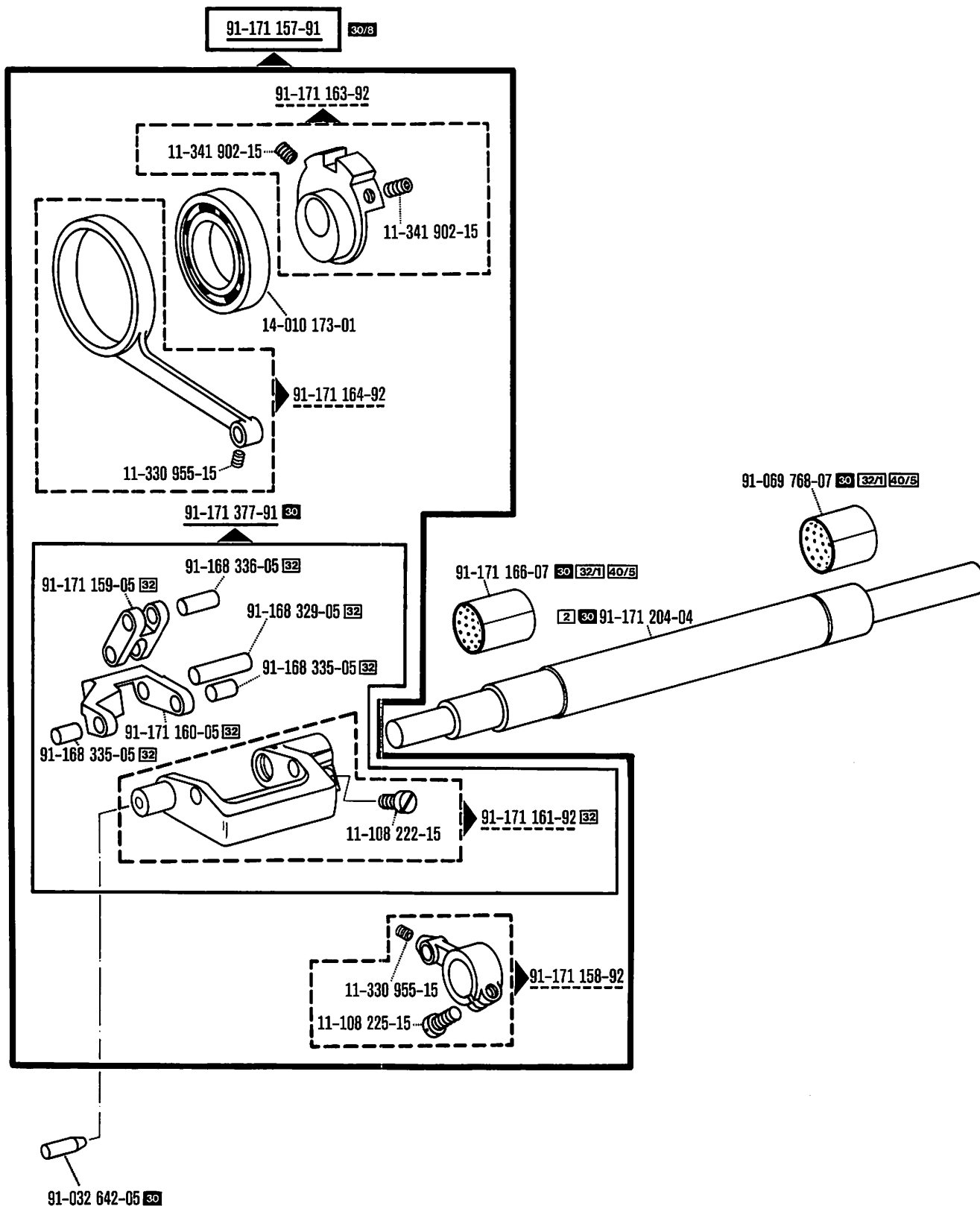

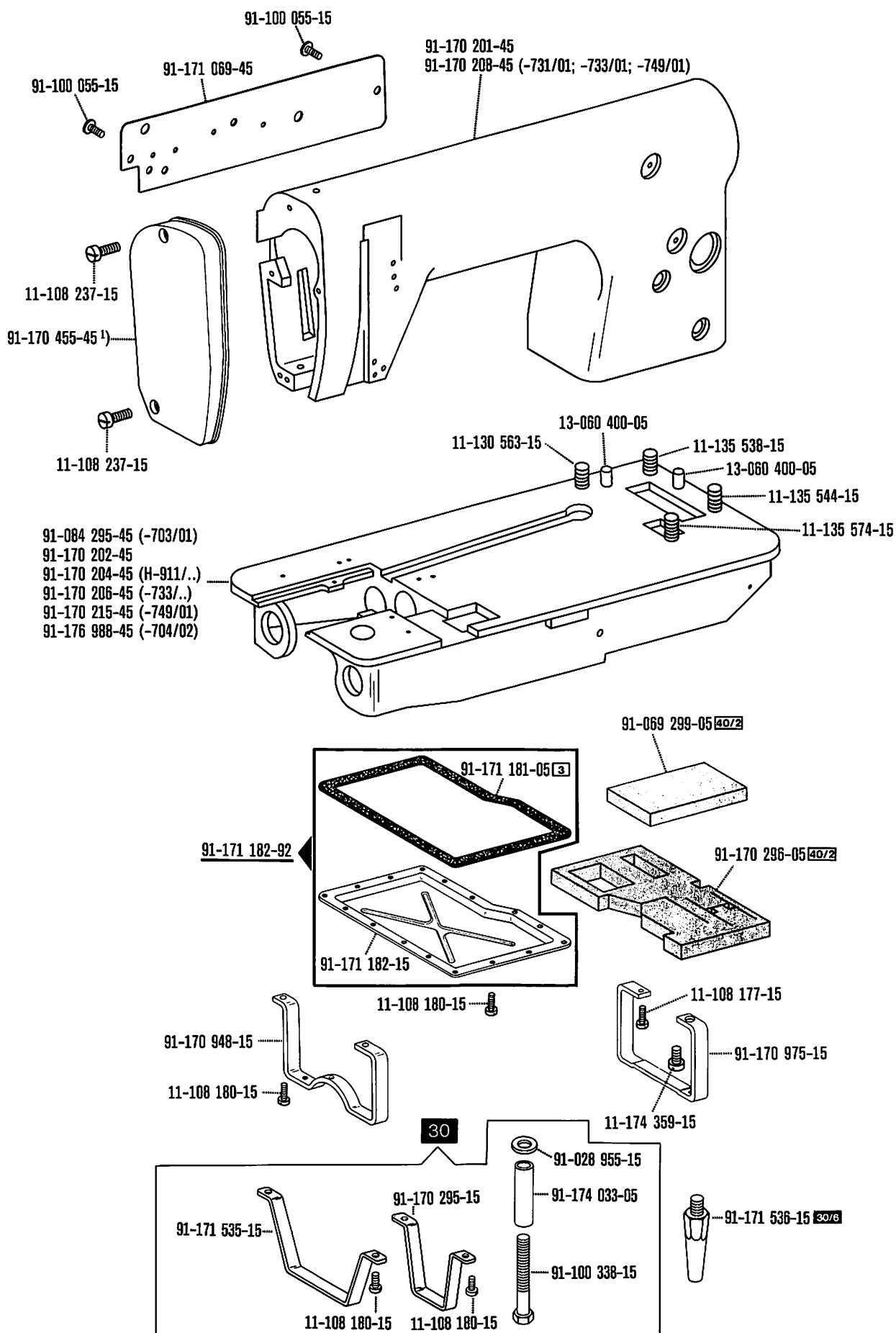

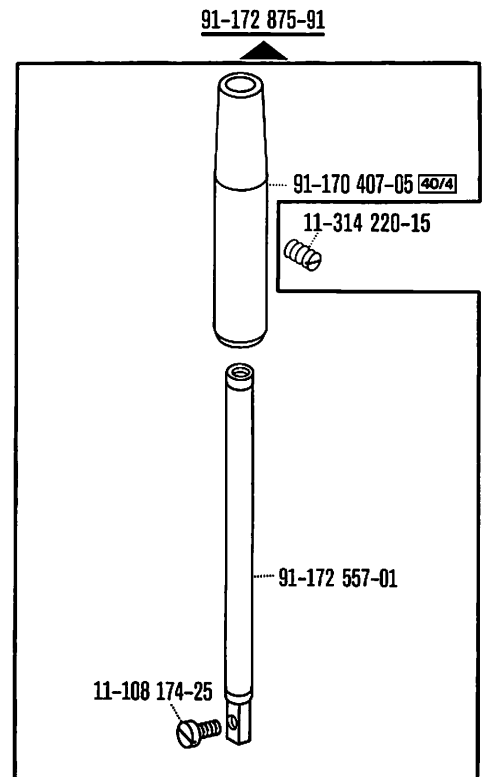
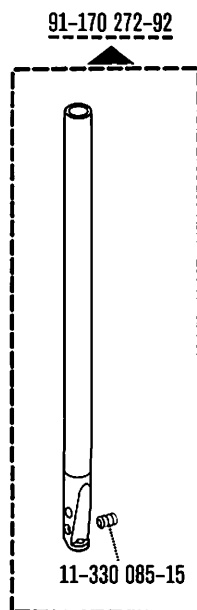
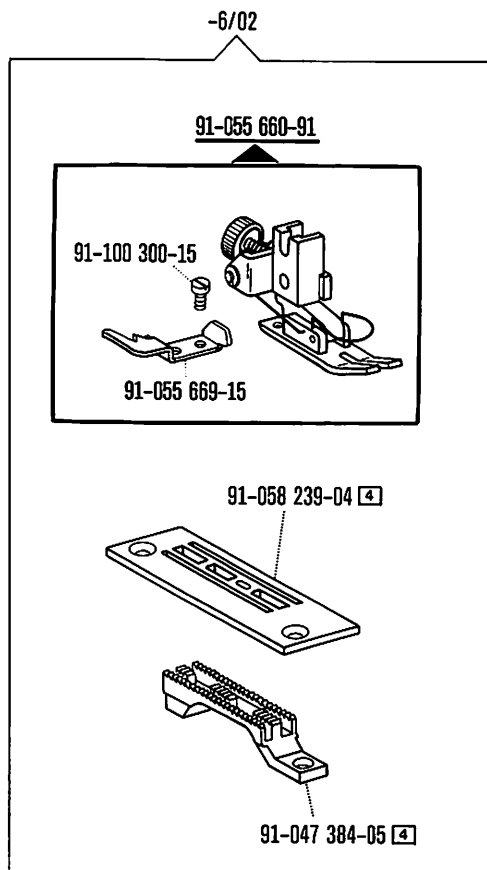
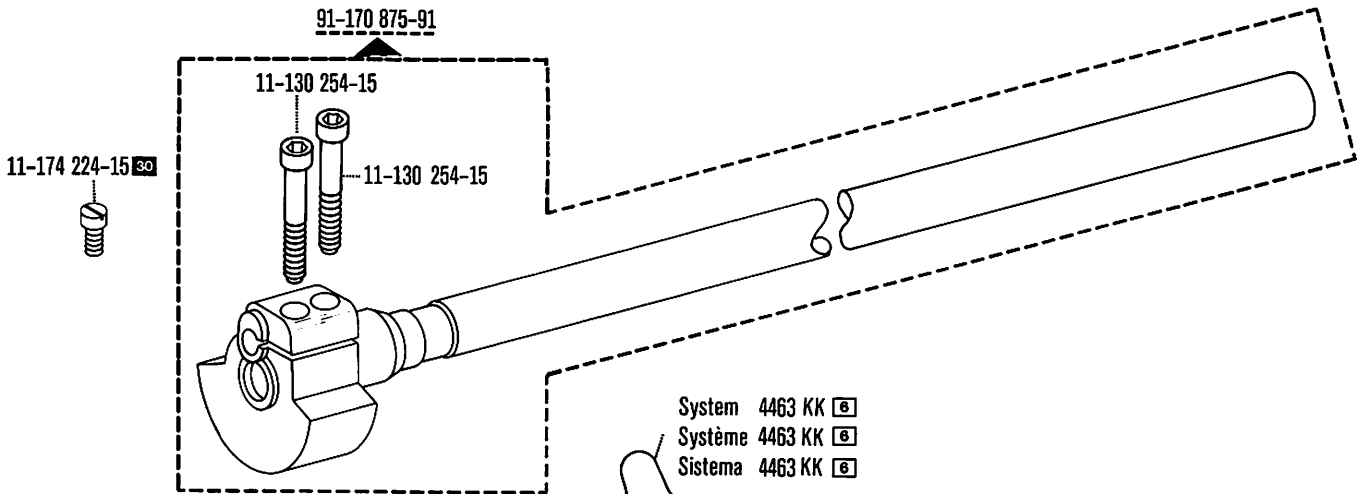
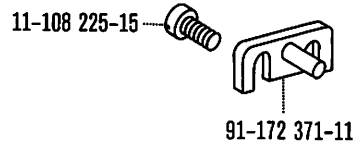
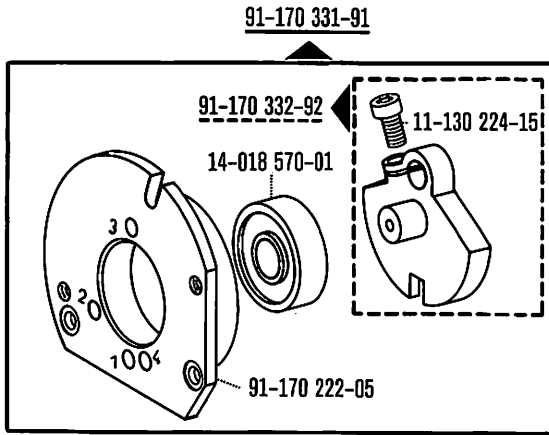

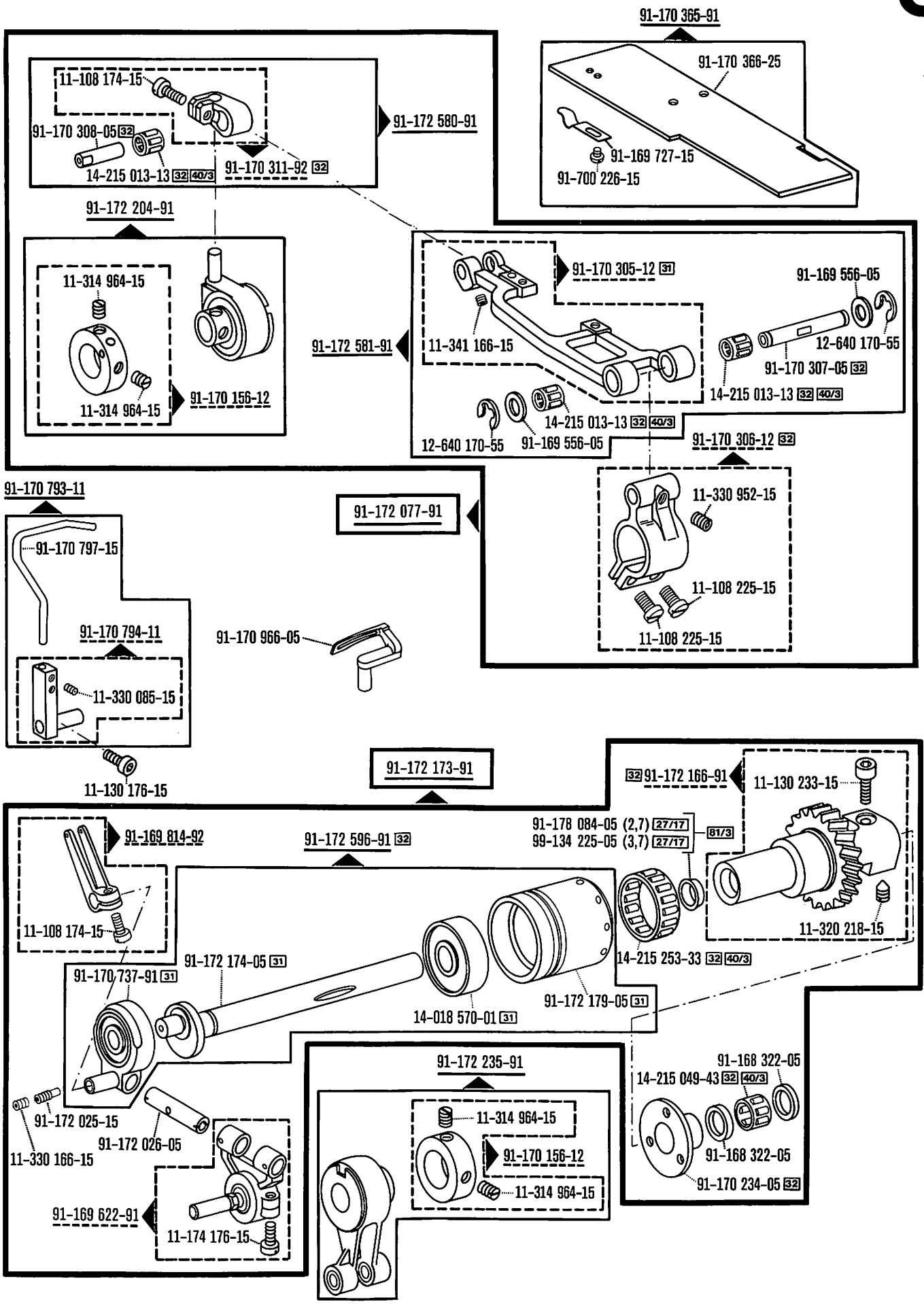

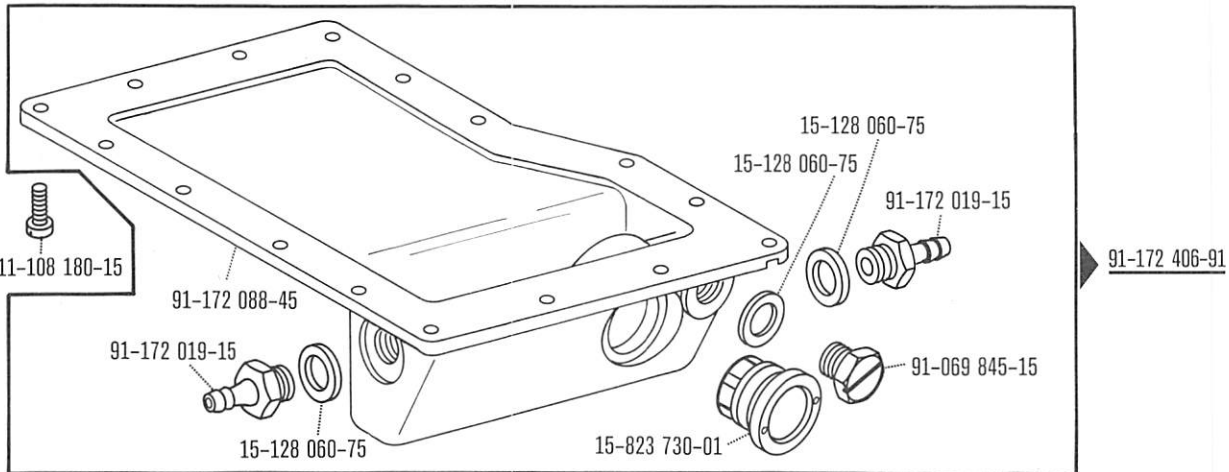
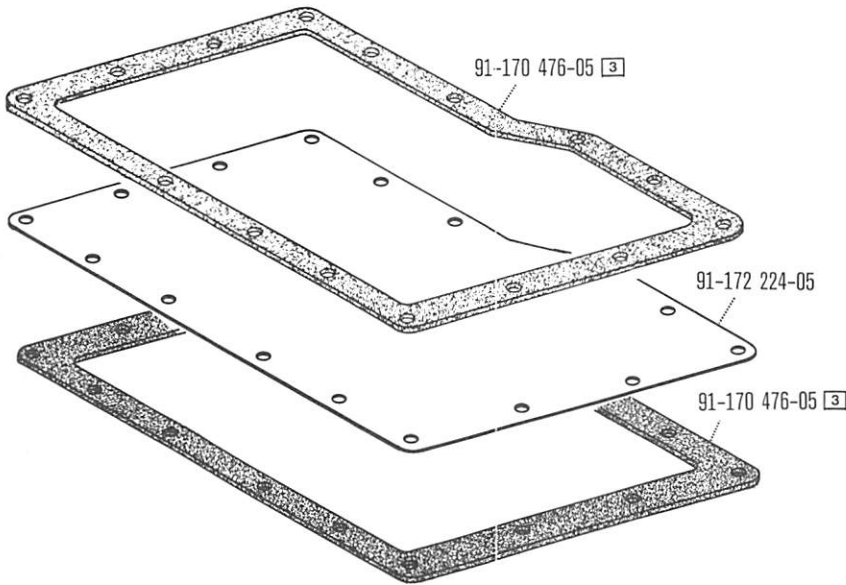
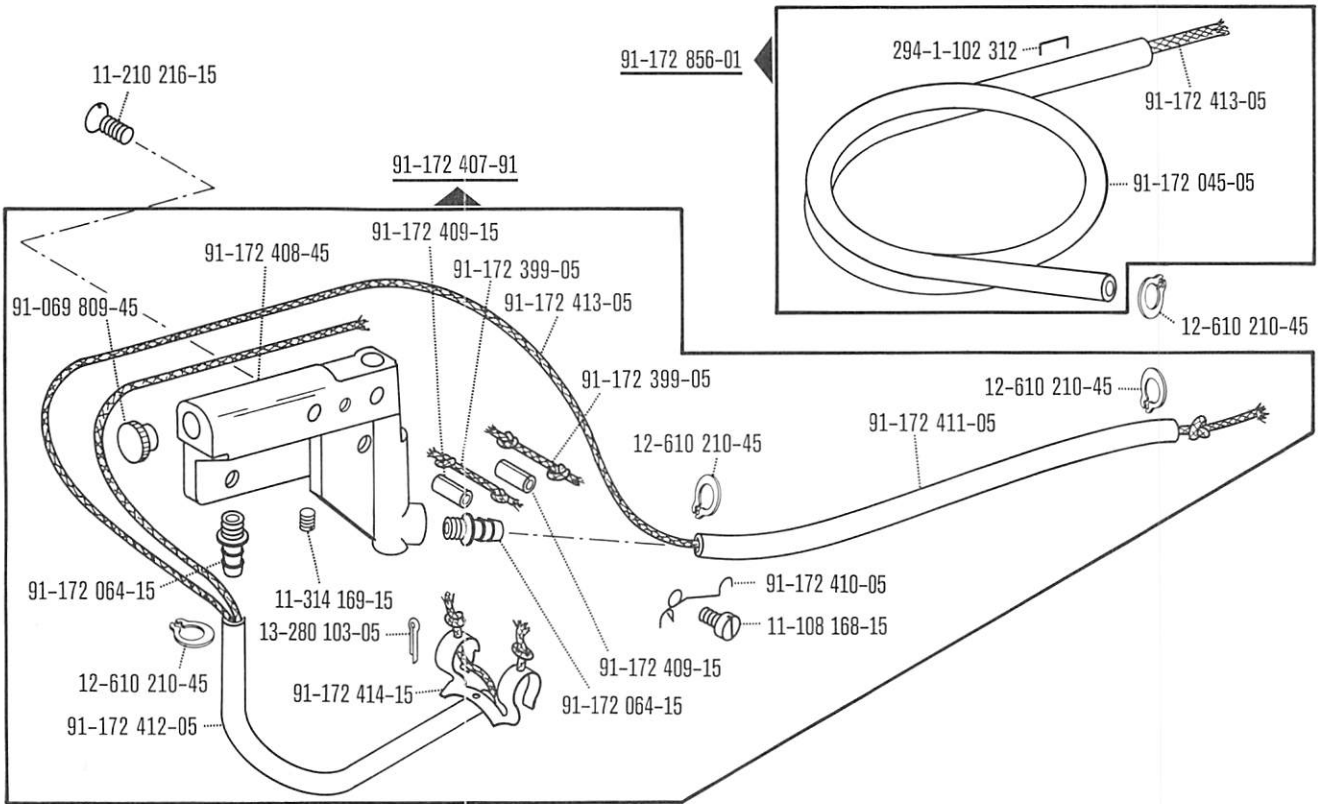

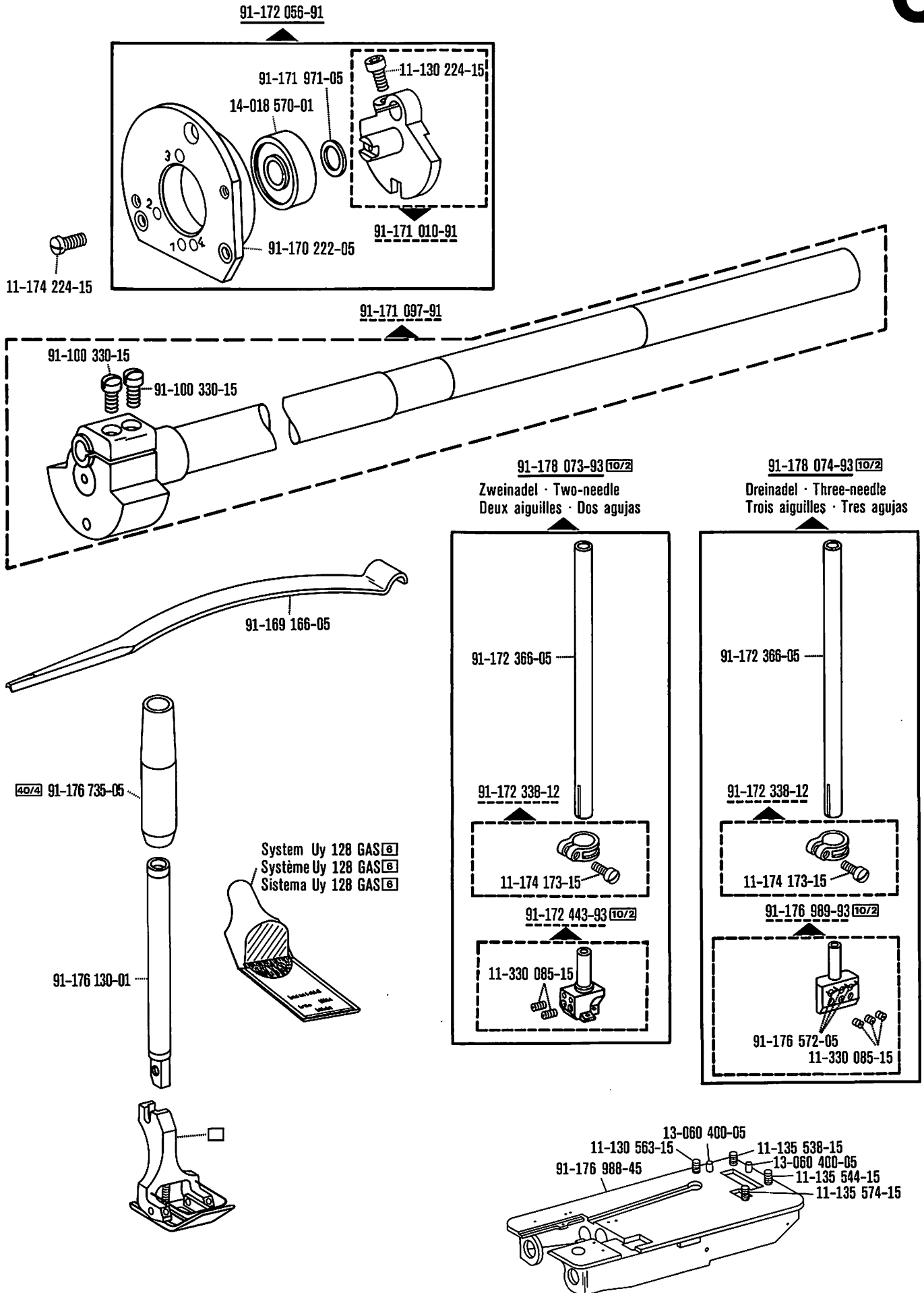

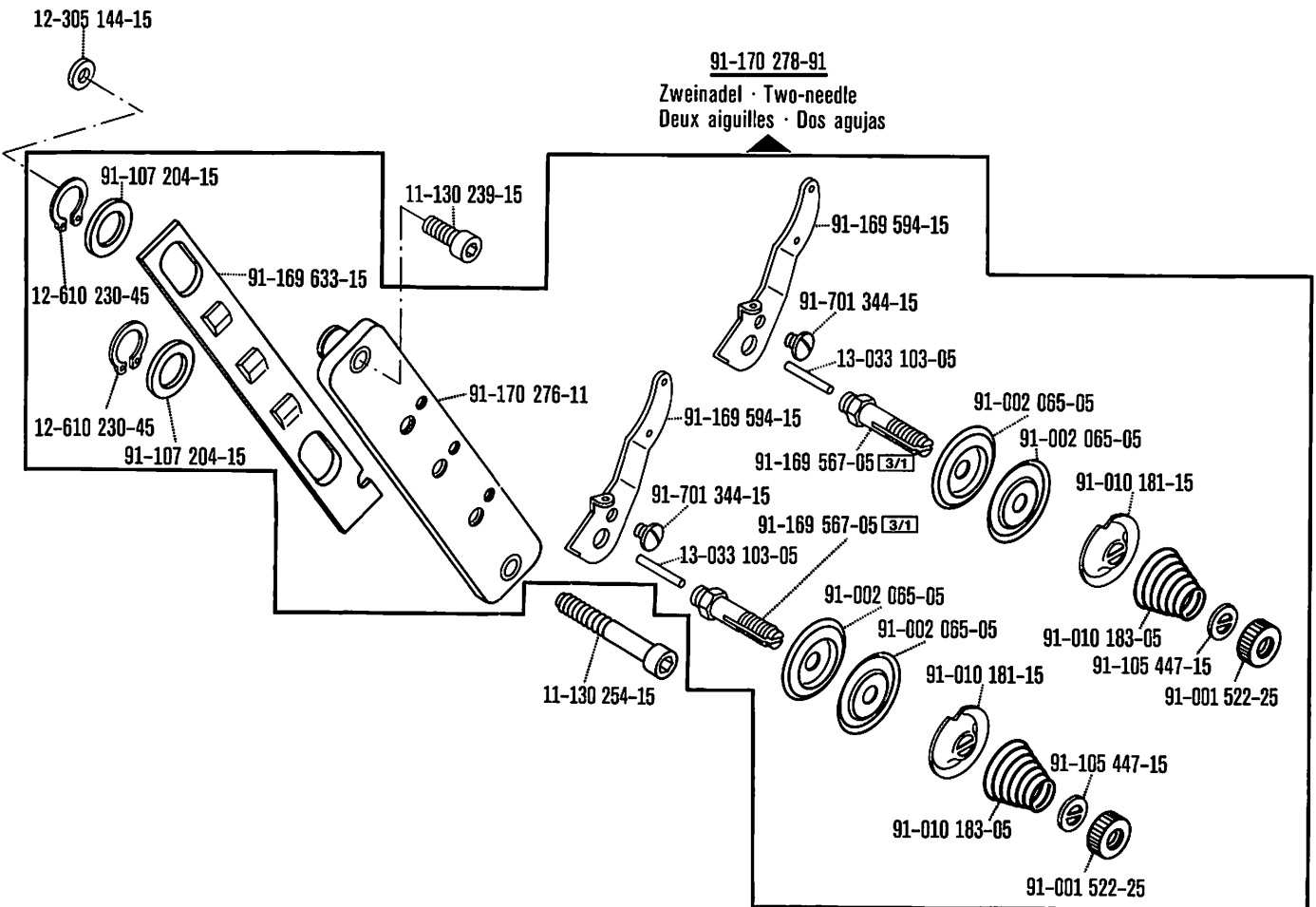
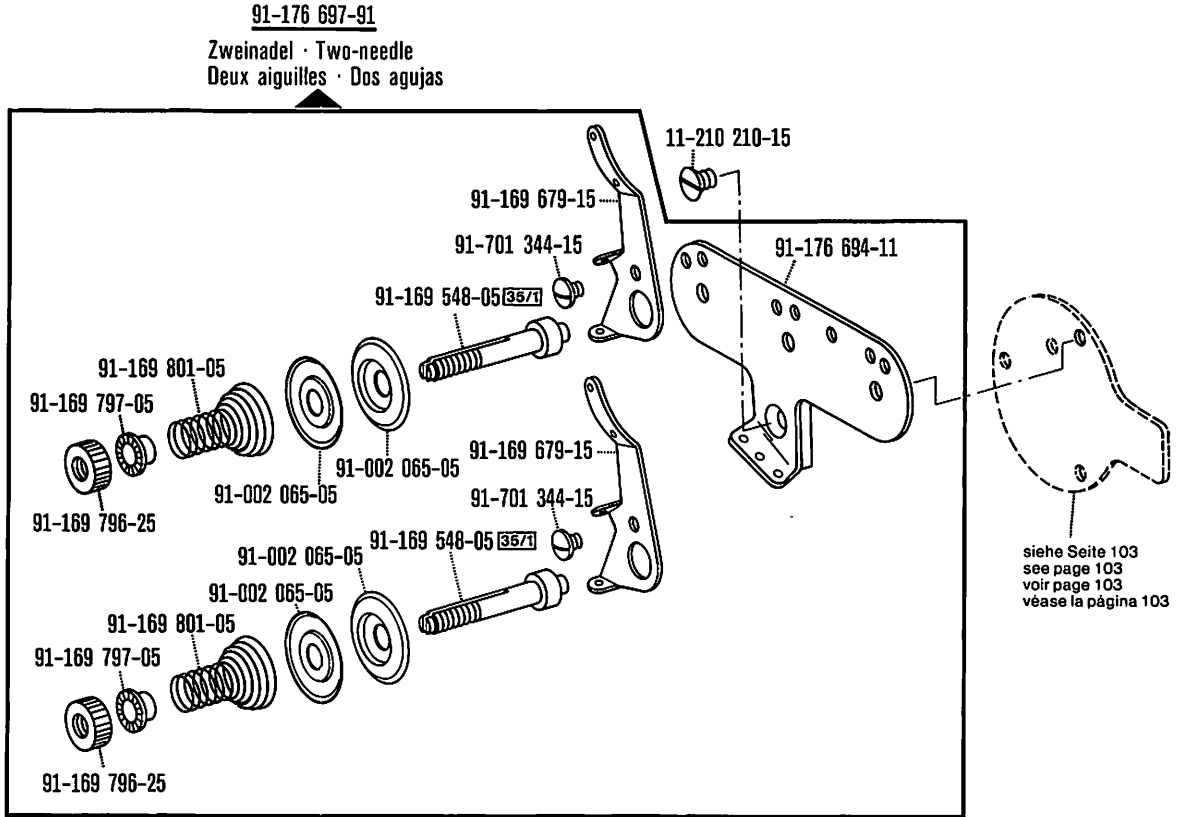

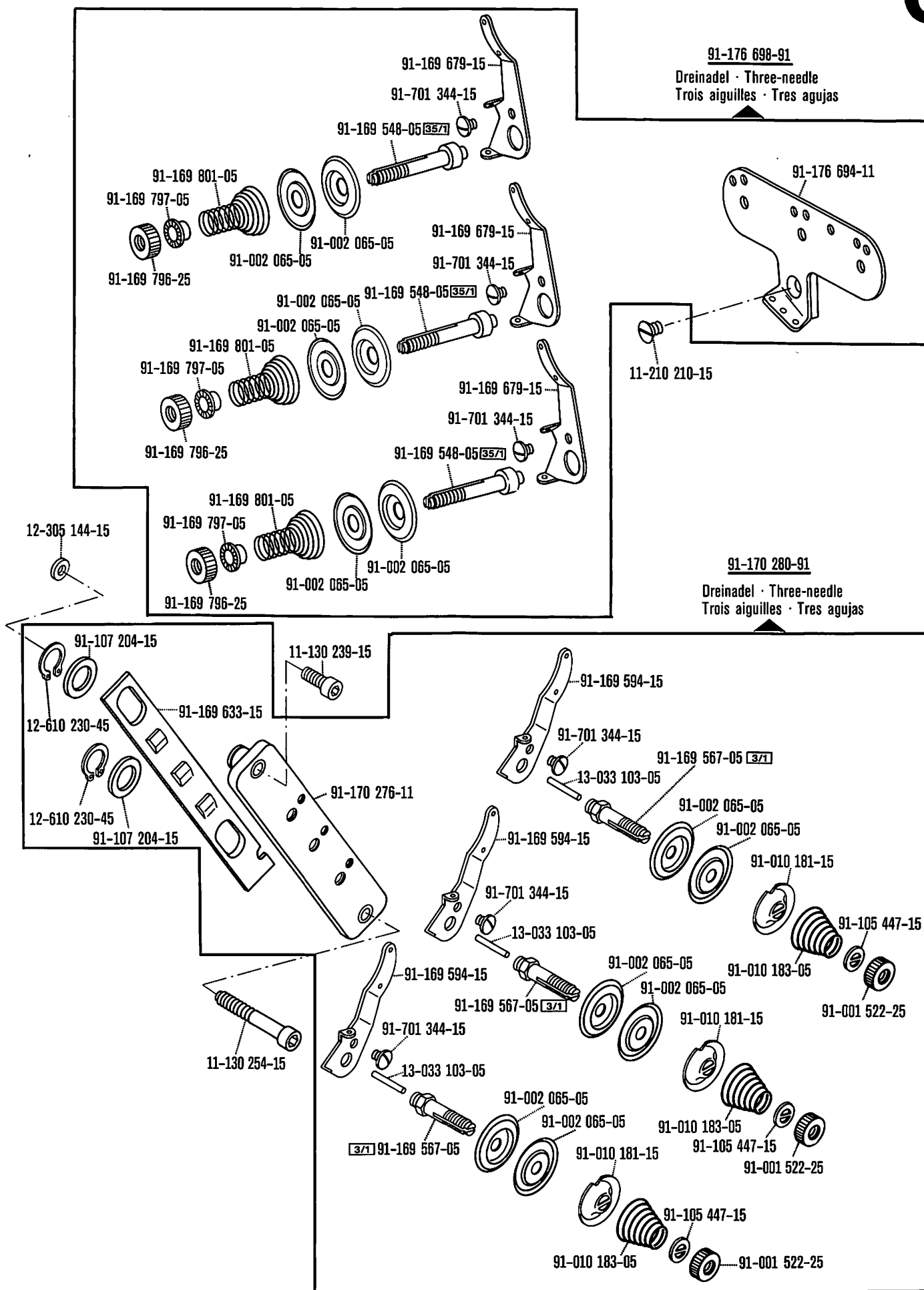

Zweinadel · Two-needle
 Deux aiguilles · Dos agujas

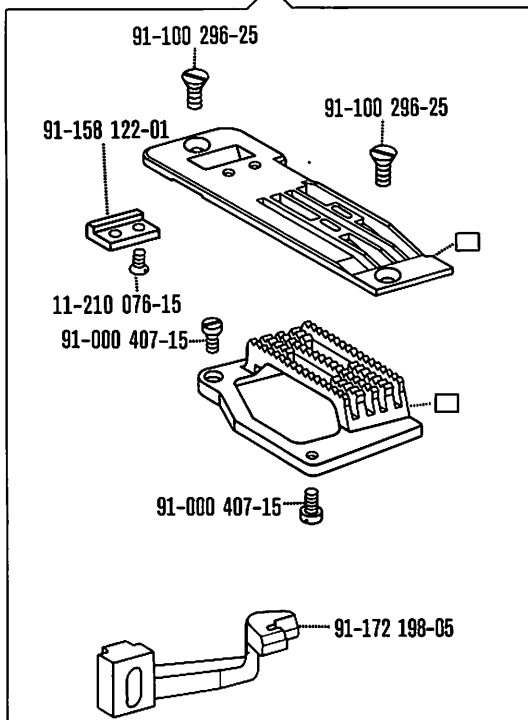

Dreinel · Three-needle
 Trois aiguilles · Tres agujas

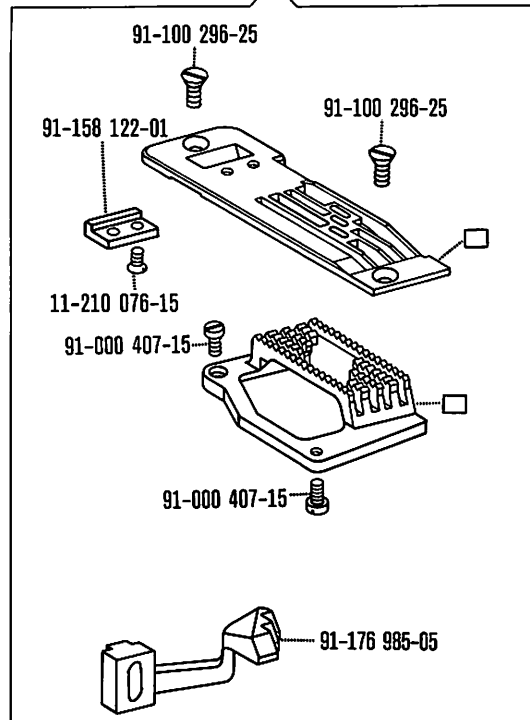

91-176 991-91

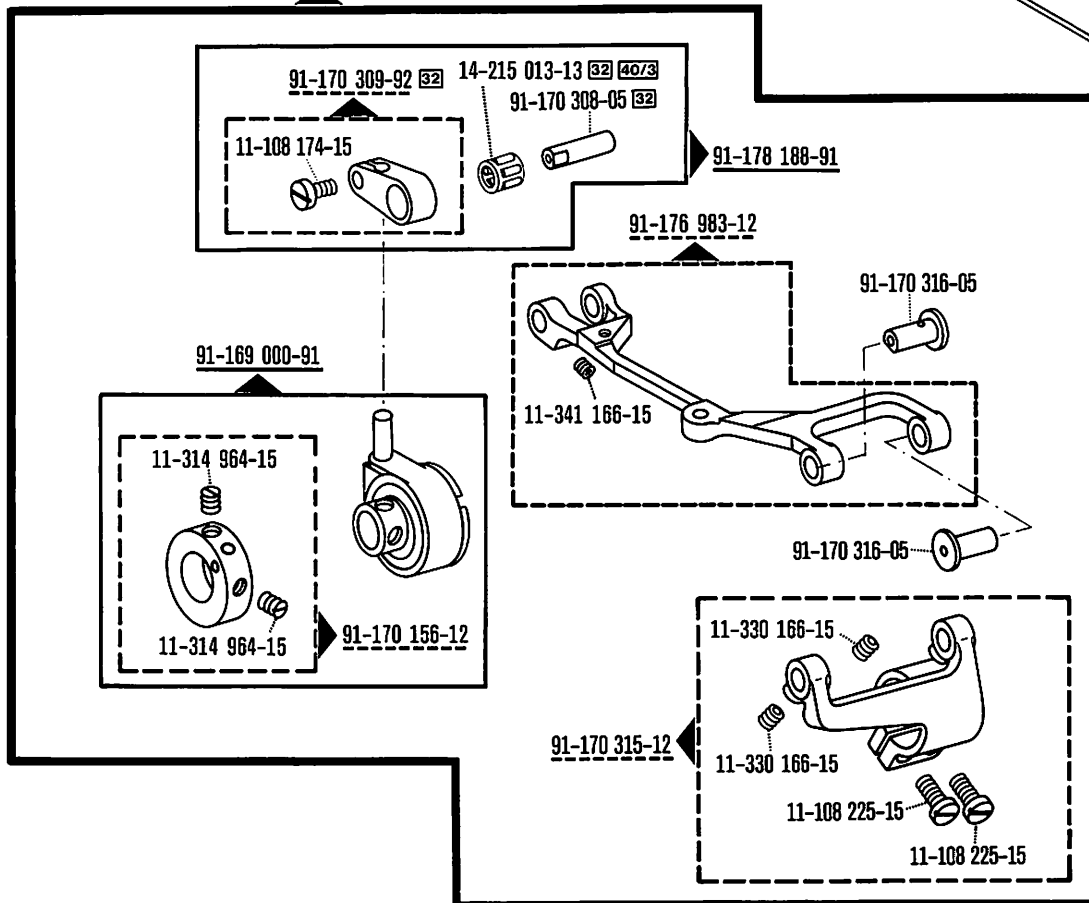

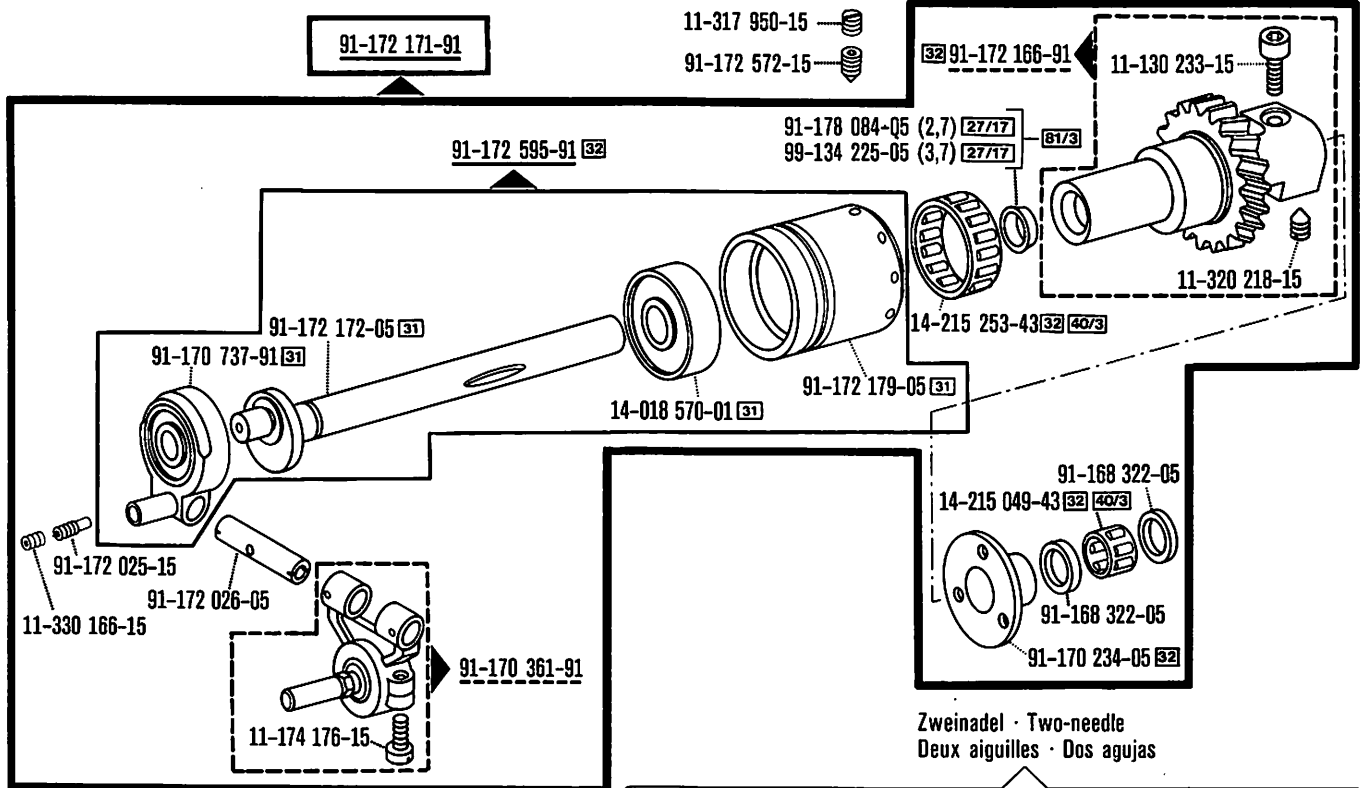

Zweinadel · Two-needle
 Deux aiguilles · Dos agujas

91-169 814-92
 Zweinadel · Two-needle
 Deux aiguilles · Dos agujas

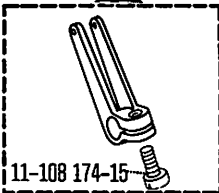

91-176 986-92
 Dreinadel · Three-needle
 Trois aiguilles · Tres agujas

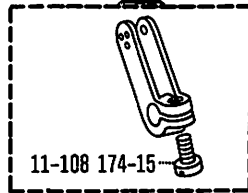

Dreinadel · Three-needle
 Trois aiguilles · Tres agujas

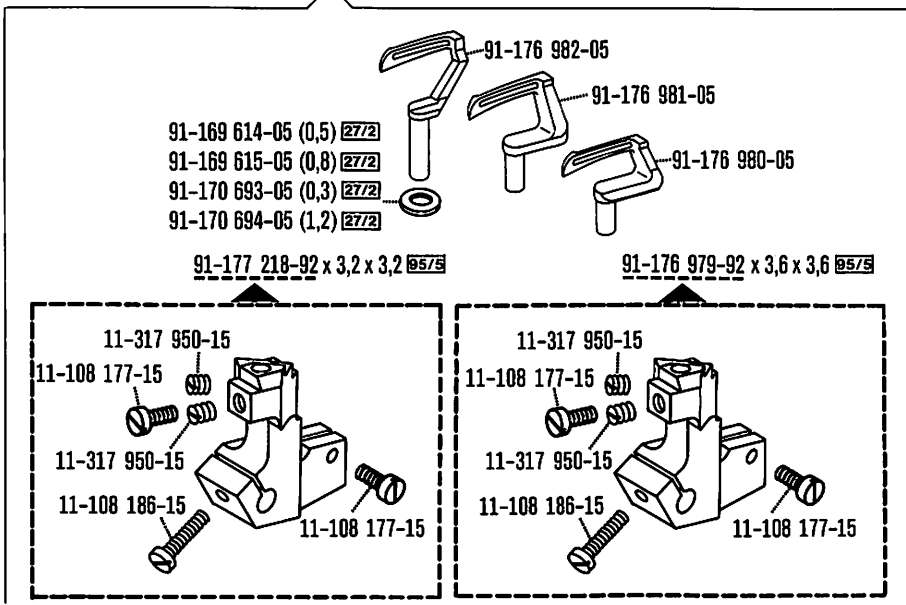
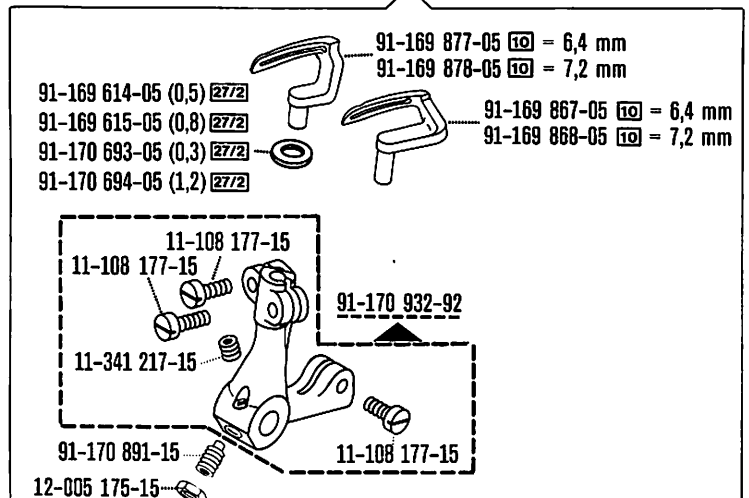

Ergänzungsteile

Complementary parts

Pièces complémentaires

Piezas especiales

Pfaff 5483 H-814/01-911/03

Pfaff 5483 H-814/01-911/05 

Pfaff 5483 H-814/01-910/04-911/05 

(die sonstigen Teile wie in Register 1 bis 4)

(for all other parts see Sections 1 to 4)

(les autres pièces comme dans les registres 1 à 4)

(las demás piezas como

en los registros 1 a 4)

9.85

91-092 210-91  (-911/05)

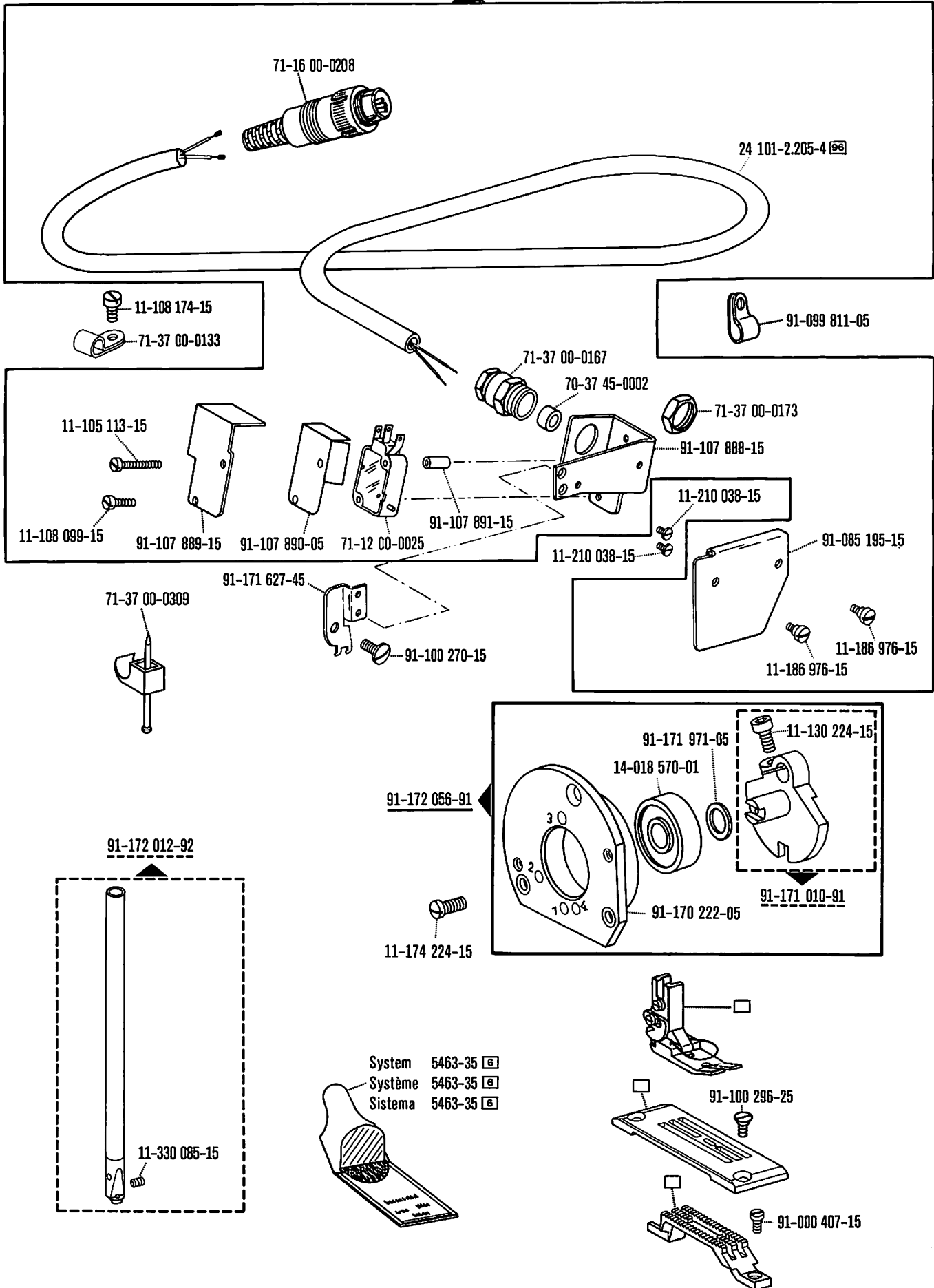

System 5463-35 

Système 5463-35 

Sistema 5463-35 

Ergänzungsteile
Complementary parts

Pièces complémentaires Pfaff 5483 H-814/01-911/05 
Piezas especiales Pfaff 5483 H-814/01-910/04-911/05 

(die sonstigen Teile wie in Register 1 bis 4)
(for all other parts see Sections 1 to 4)
(les autres pièces comme dans les registres 1 à 4)
(las demás piezas como en los registros 1 al 4)

9.85

7

91-091 585-91  30

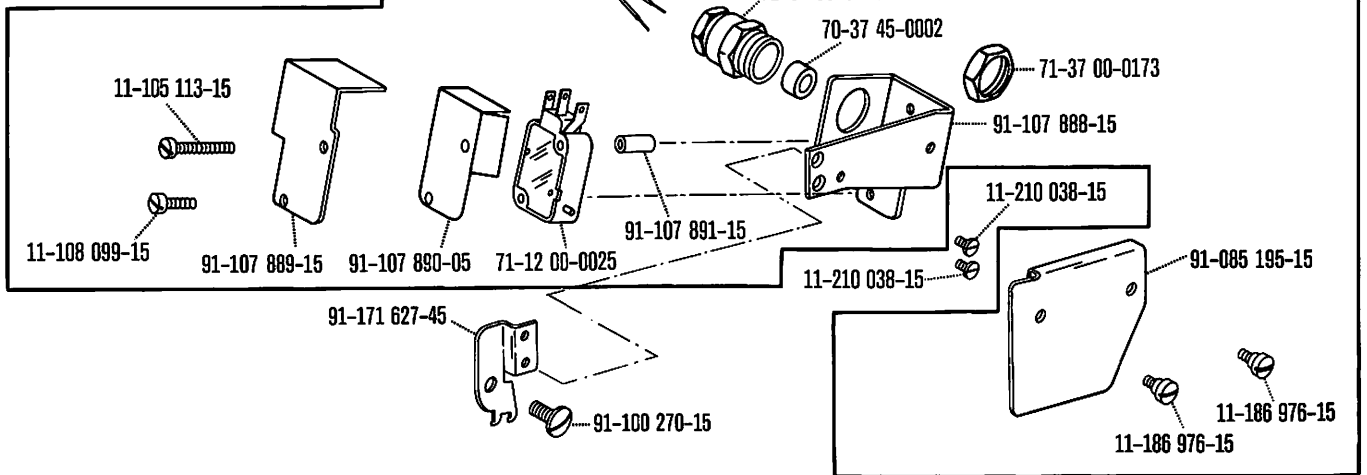
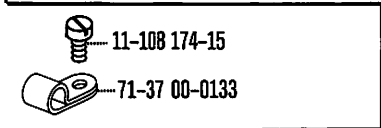
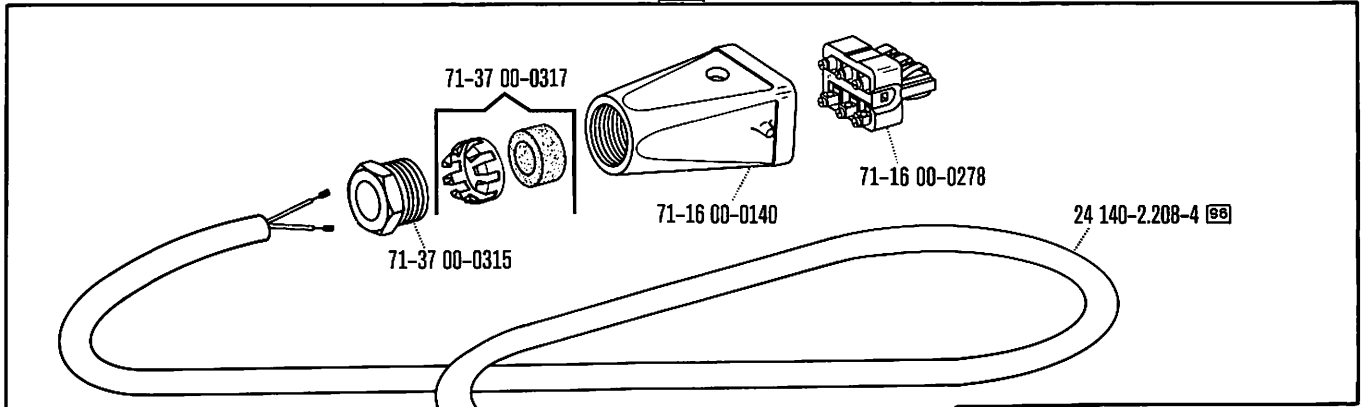

11-460 109-15

91-091 587-91  30

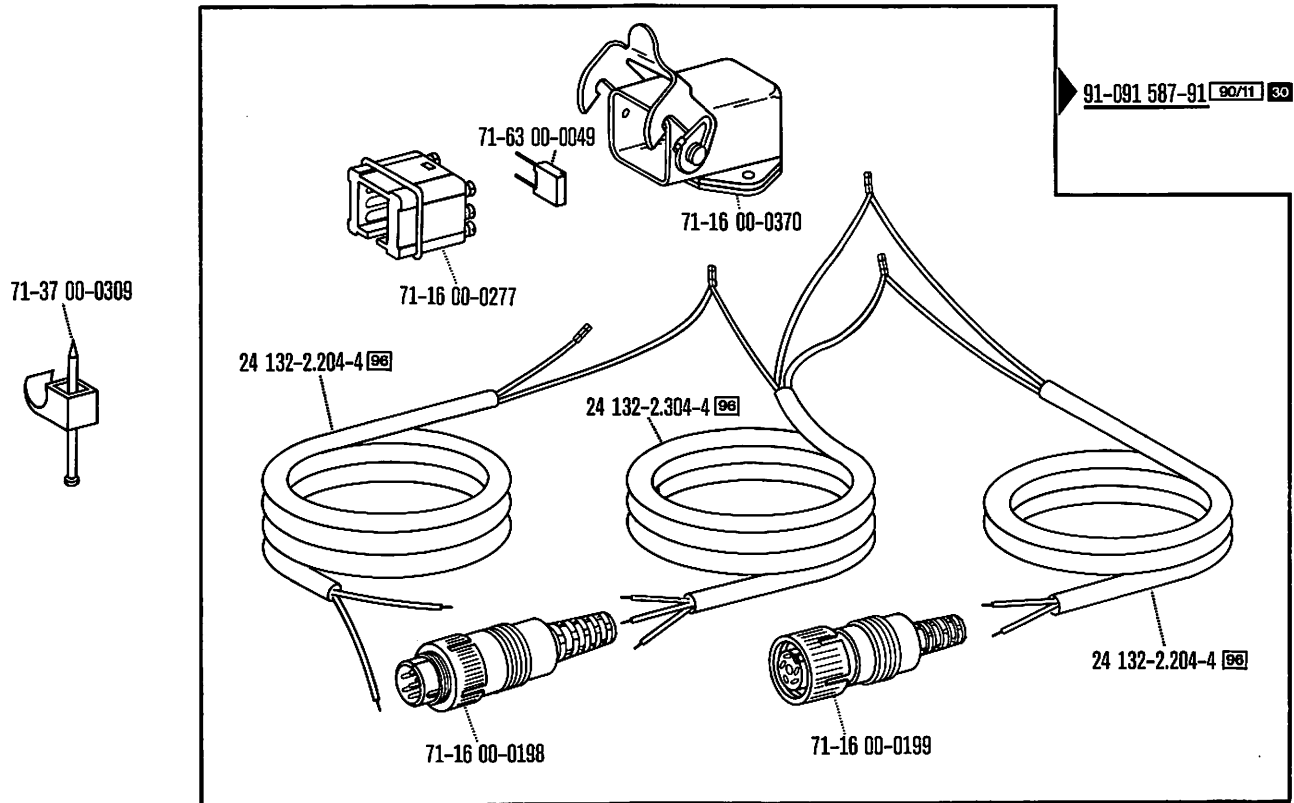

Ergänzungsteile
Complementary parts
Pièces complémentaires
Piezas especiales

Pfaff 5483 H-814/01-911/03
Pfaff 5483 H-814/01-911/05 ^{90/19}
Pfaff 5483 H-814/01-910/04-911/05 ^{90/19}

(die sonstigen Teile wie in Register 1 bis 4)
 (for all other parts see Sections 1 to 4)
 (les autres pièces comme dans les registres 1 à 4)
 (las demás piezas como en los registros 1 a 4)

9.85

7

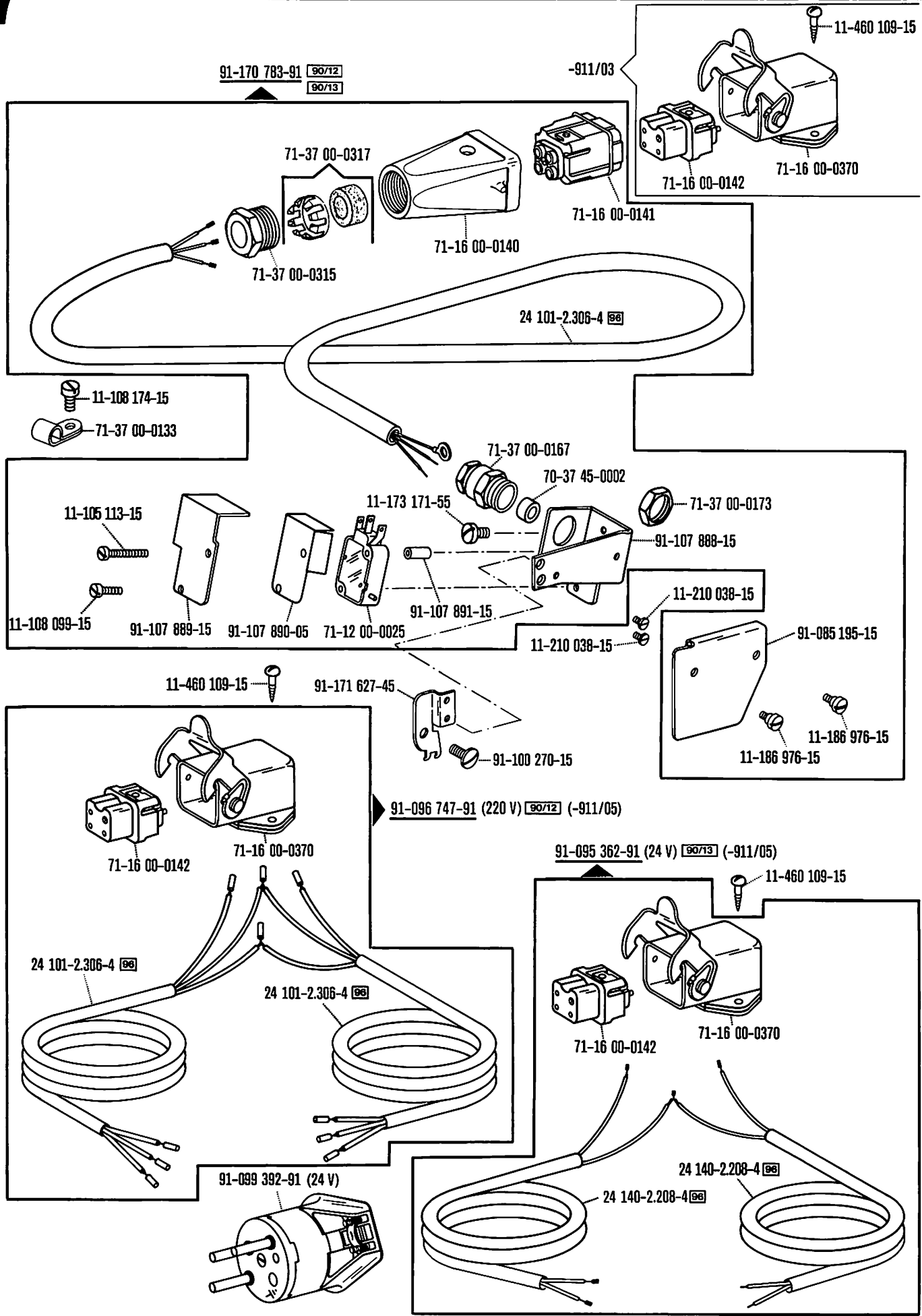

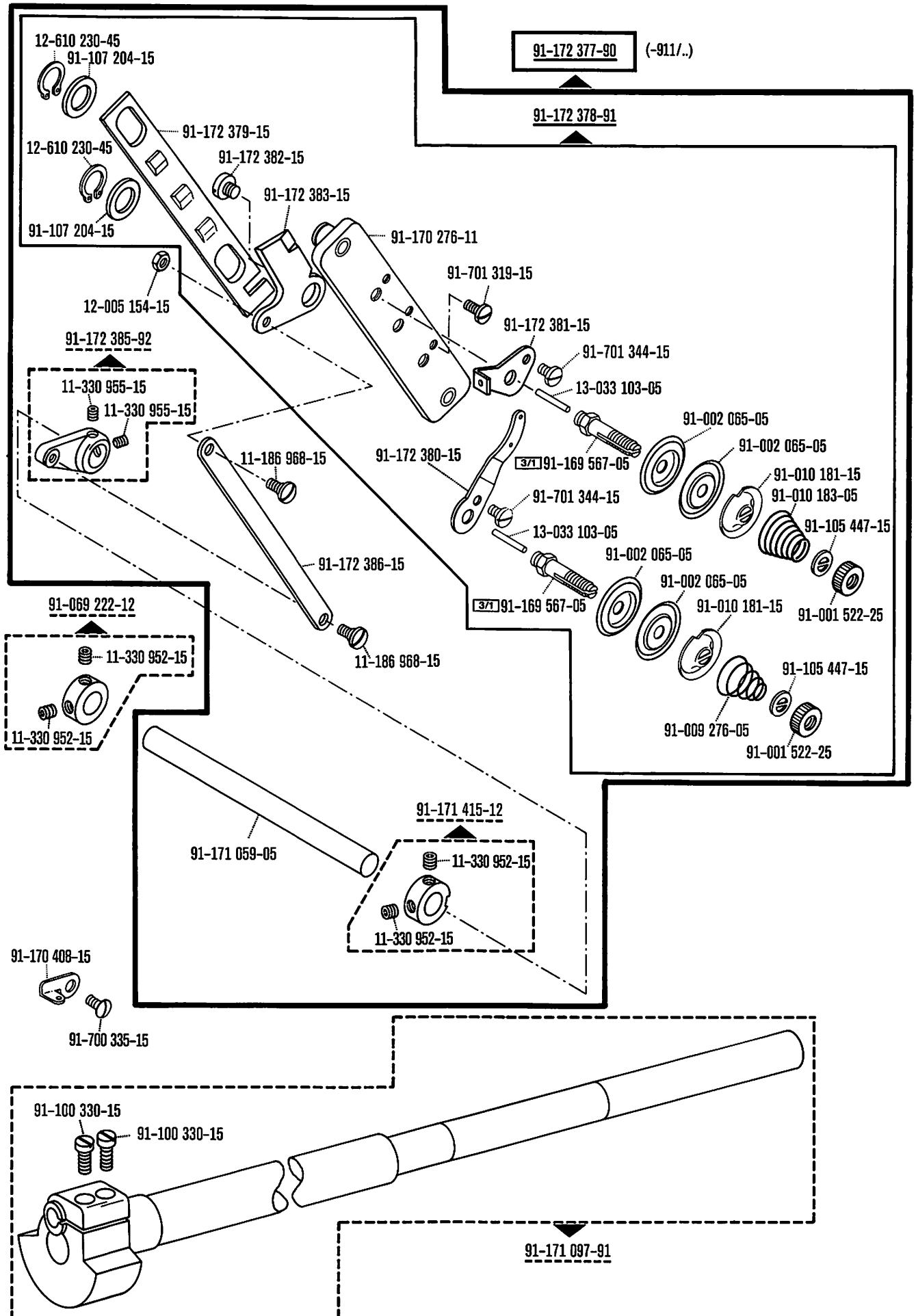

7

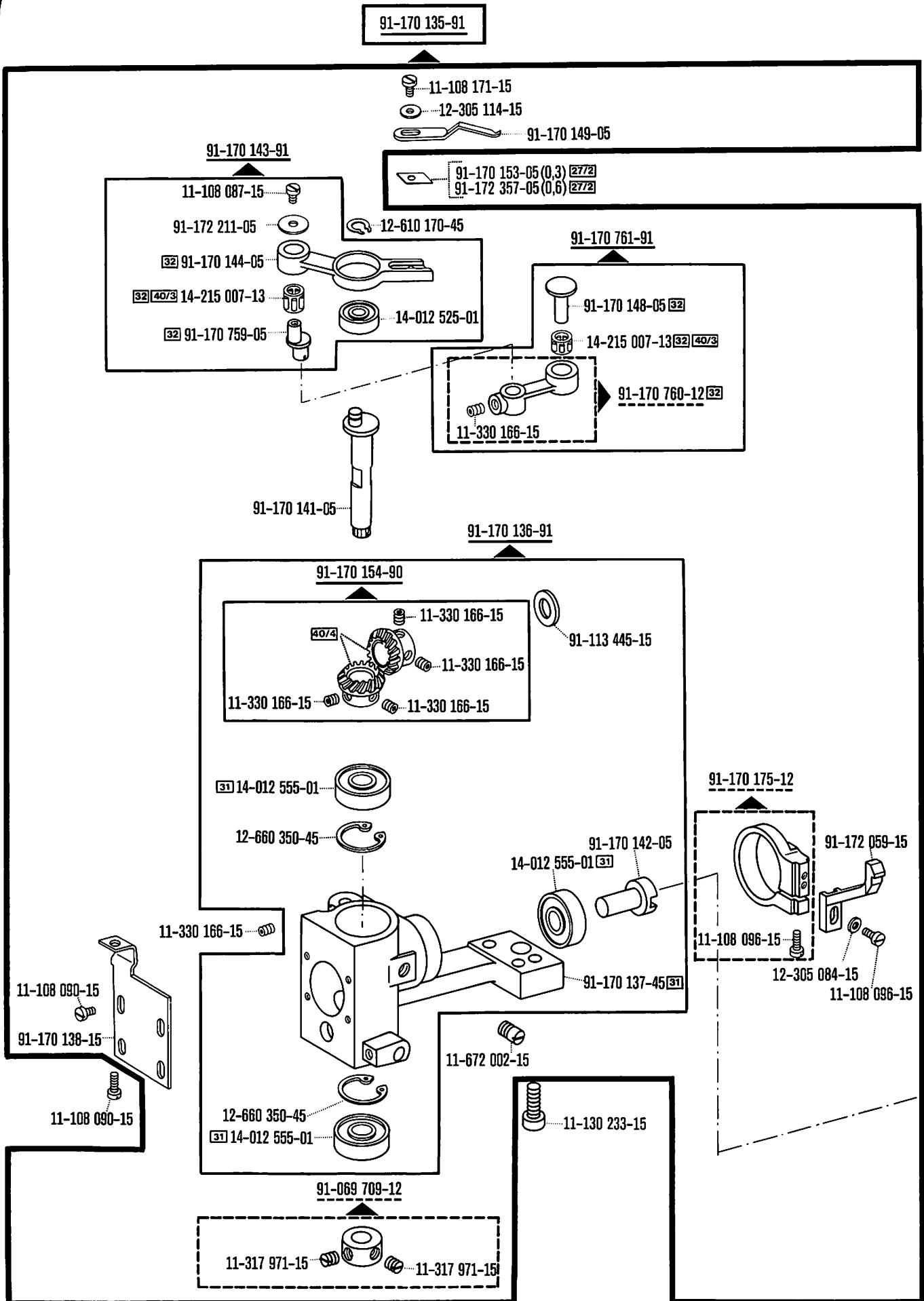

Ergänzungsteile

Complementary parts

Pièces complémentaires

Piezas especiales

Pfaff 5483 H-814/01-911/03

Pfaff 5483 H-814/01-911/05 90/19

Pfaff 5483 H-814/01-910/04-911/05 90/19

(die sonstigen Teile wie in Register 1 bis 4)

(for all other parts see Sections 1 to 4)

(les autres pièces comme dans les registres 1 à 4)

(las demás piezas como

en los registros 1 al 4)

9.85

7

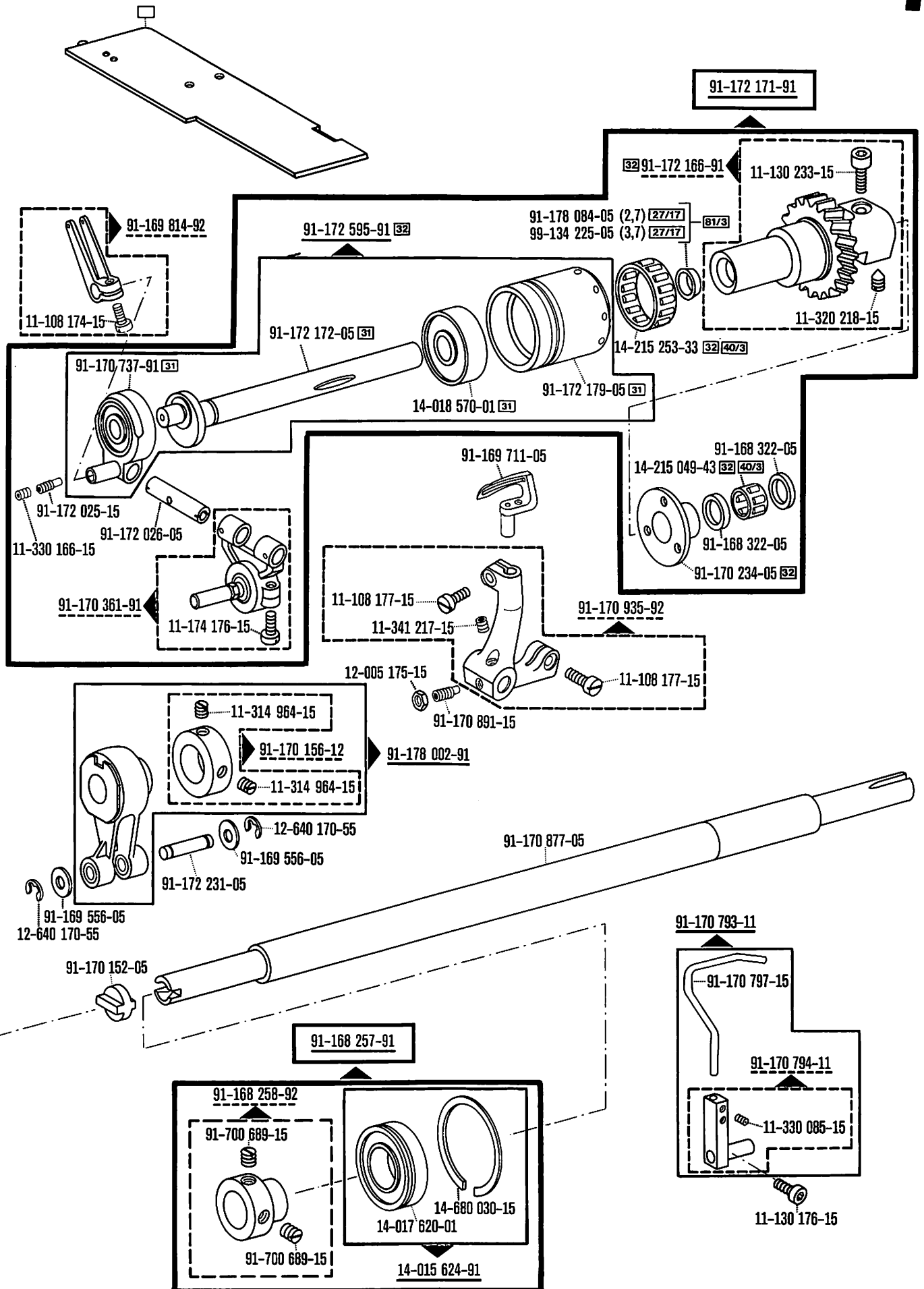

Ergänzungsteile

Complementary parts

Pièces complémentaires

Piezas especiales

Pfaff 5483 H-814/01-911/03

Pfaff 5483 H-814/01-911/05 90/19

Pfaff 5483 H-814/01-910/04-911/05 90/19

(die sonstigen Teile wie in Register 1 bis 4)

(for all other parts see Sections 1 to 4)

(les autres pièces comme dans les registres 1 à 4)

(las demás piezas como

en los registros 1 al 4)

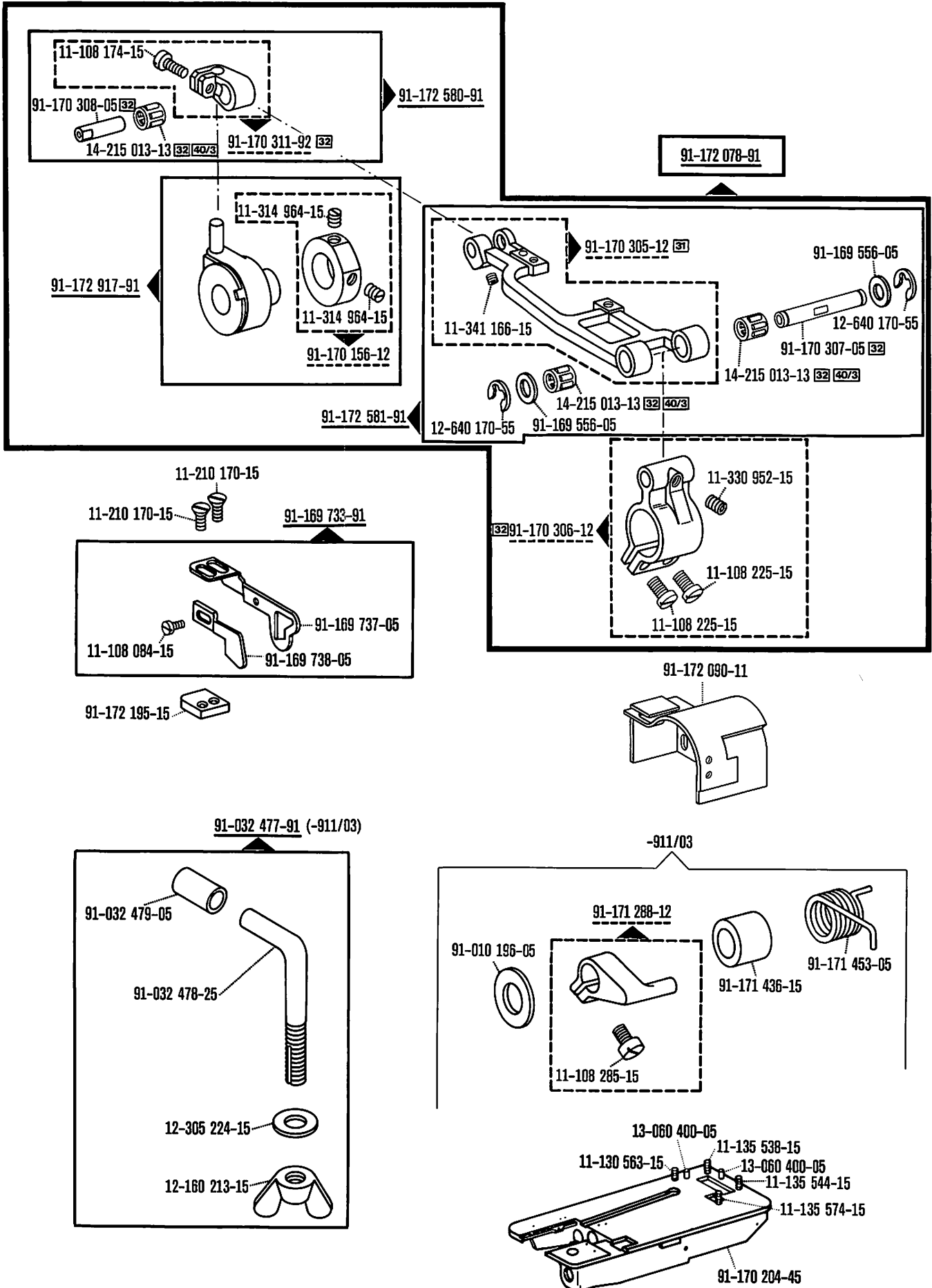

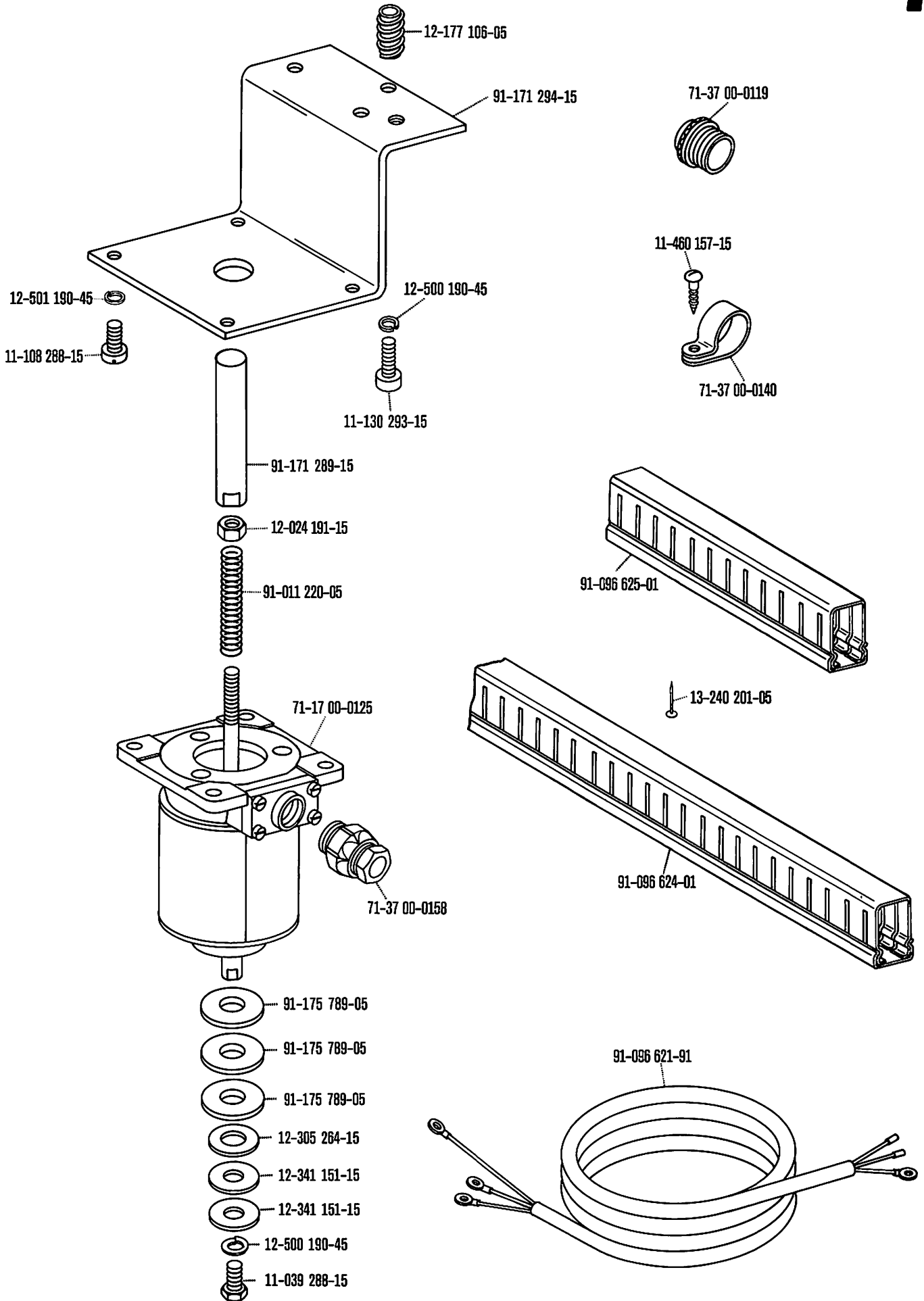

7

91-091 862-91

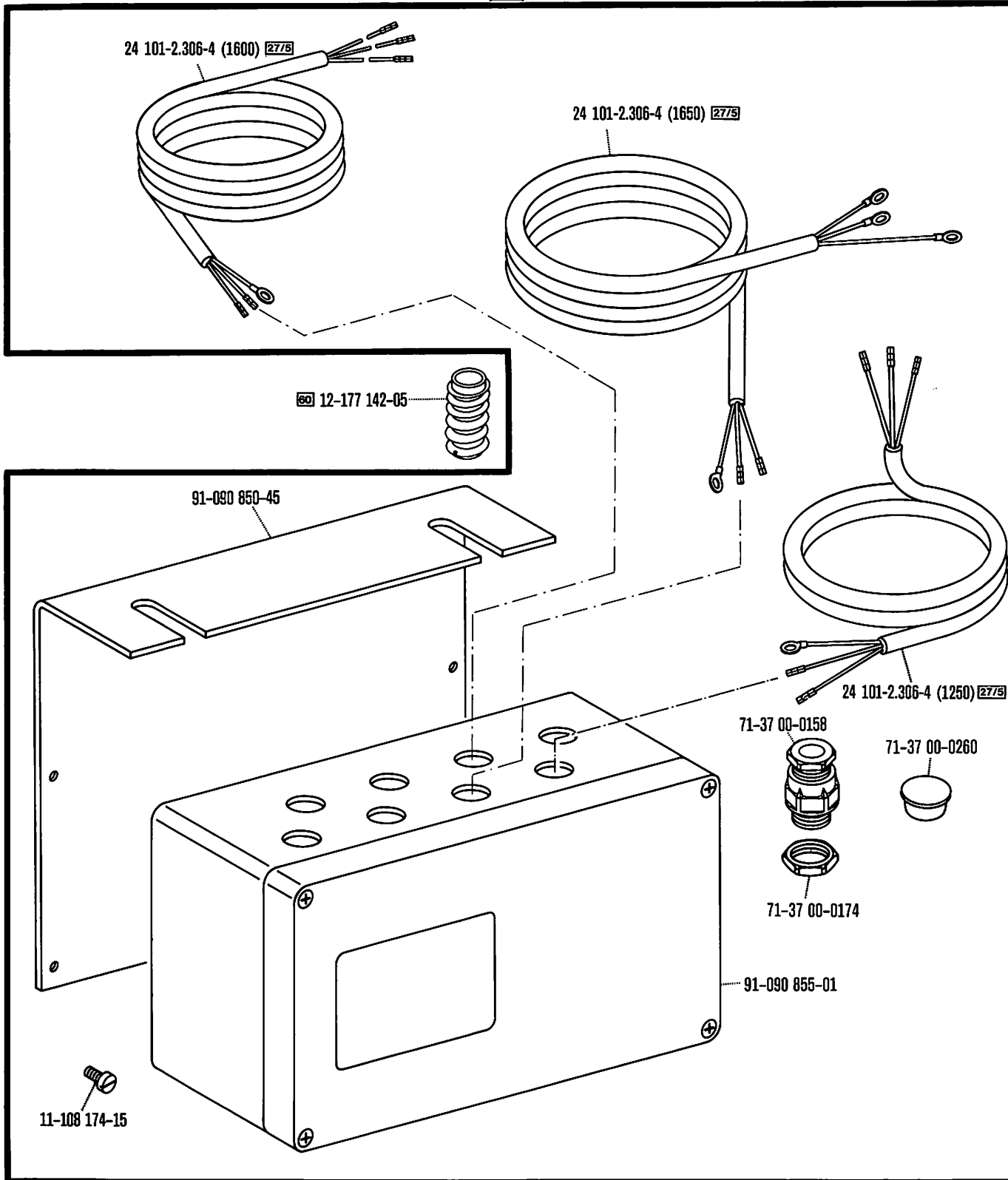

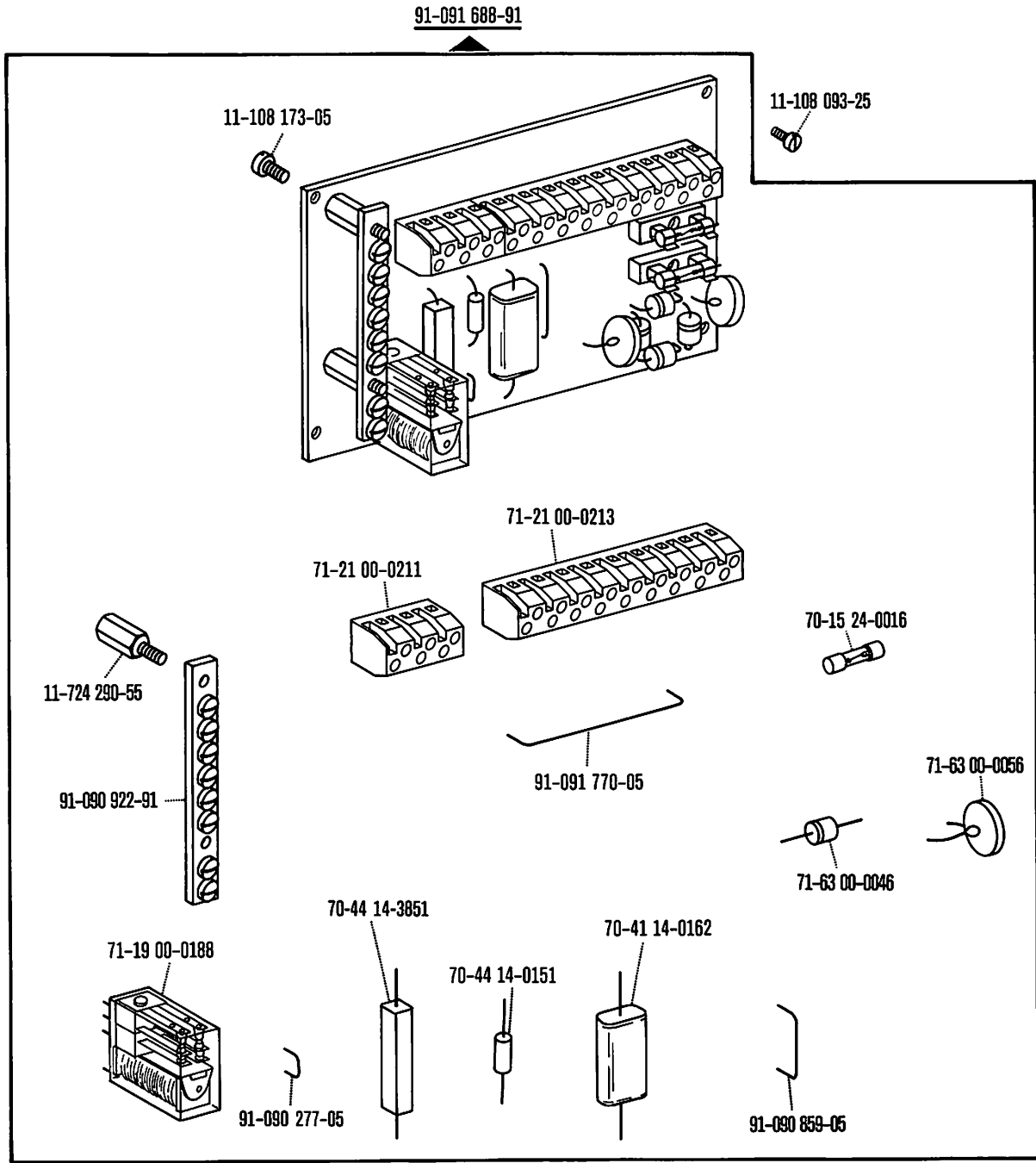

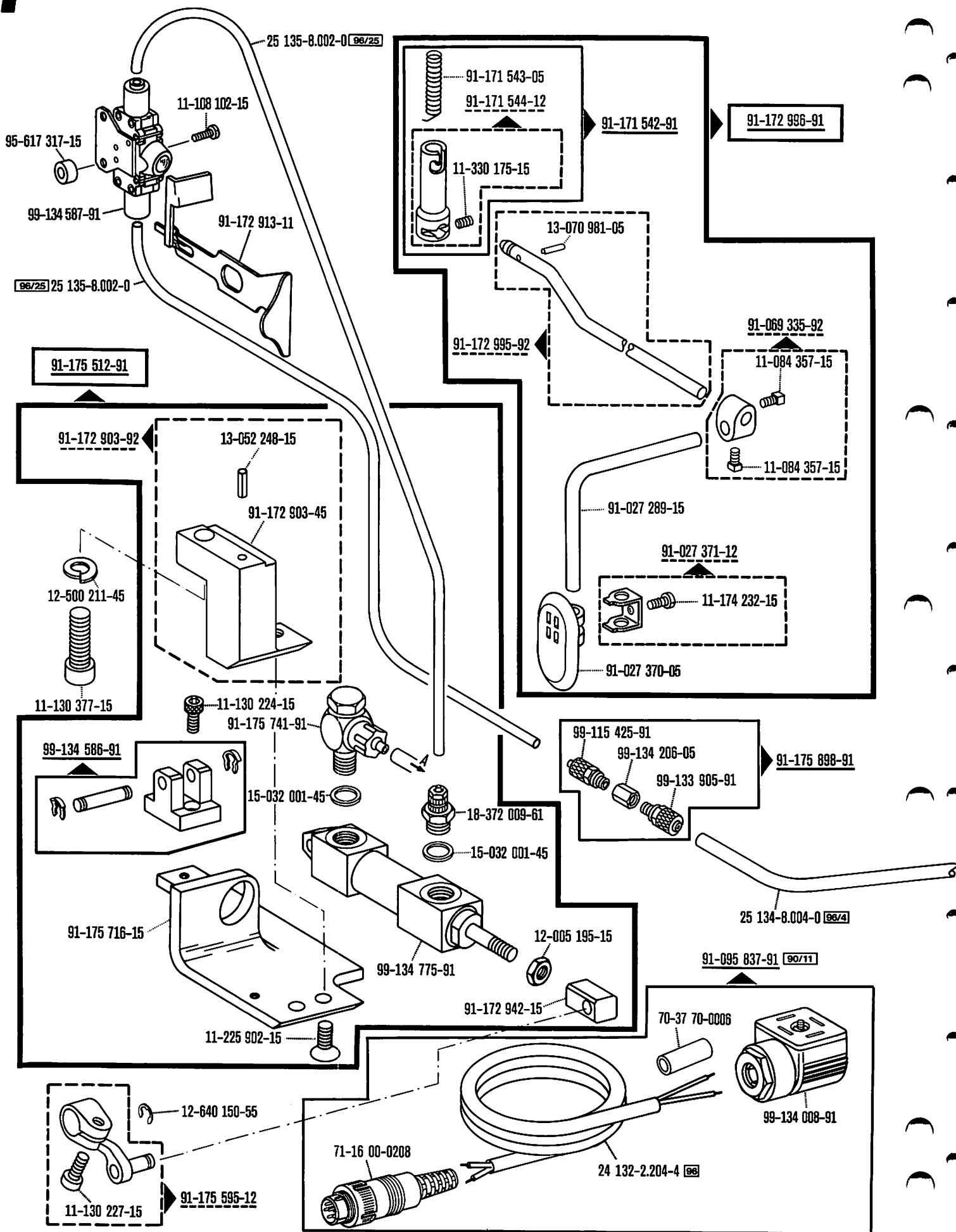

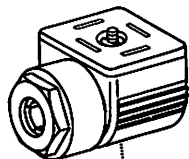
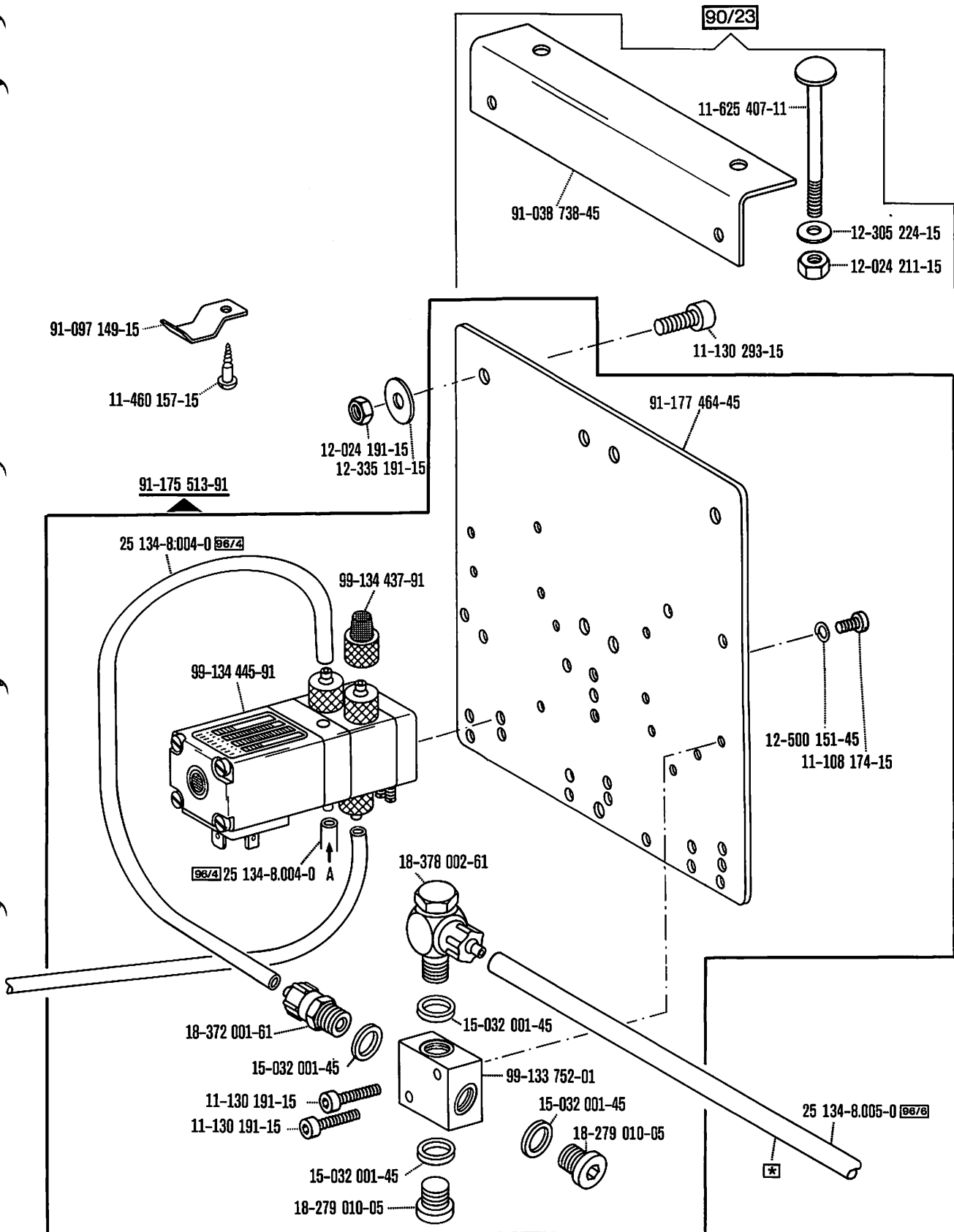

99-134 008-91 ^{90/12} ^{90/13}

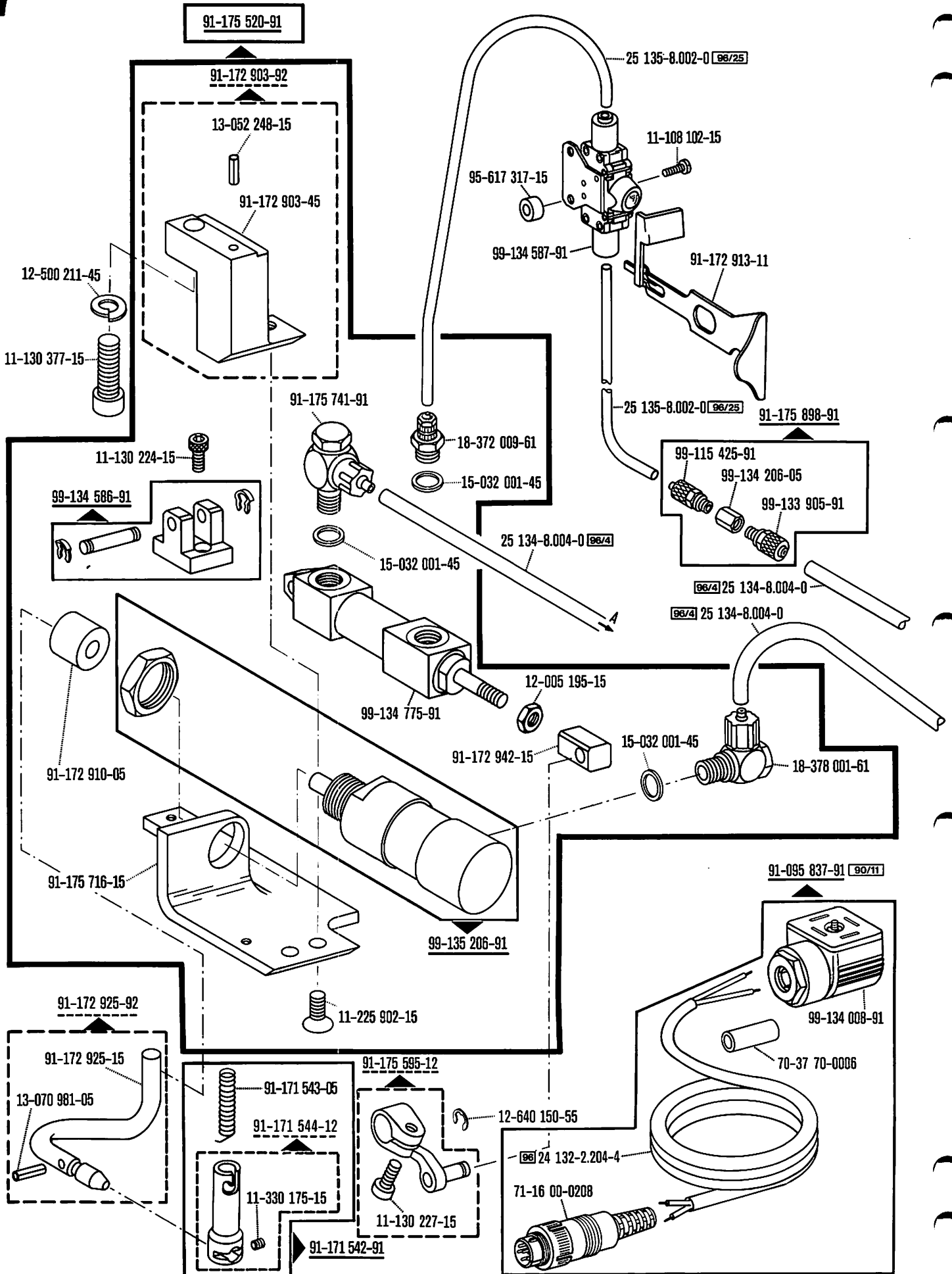

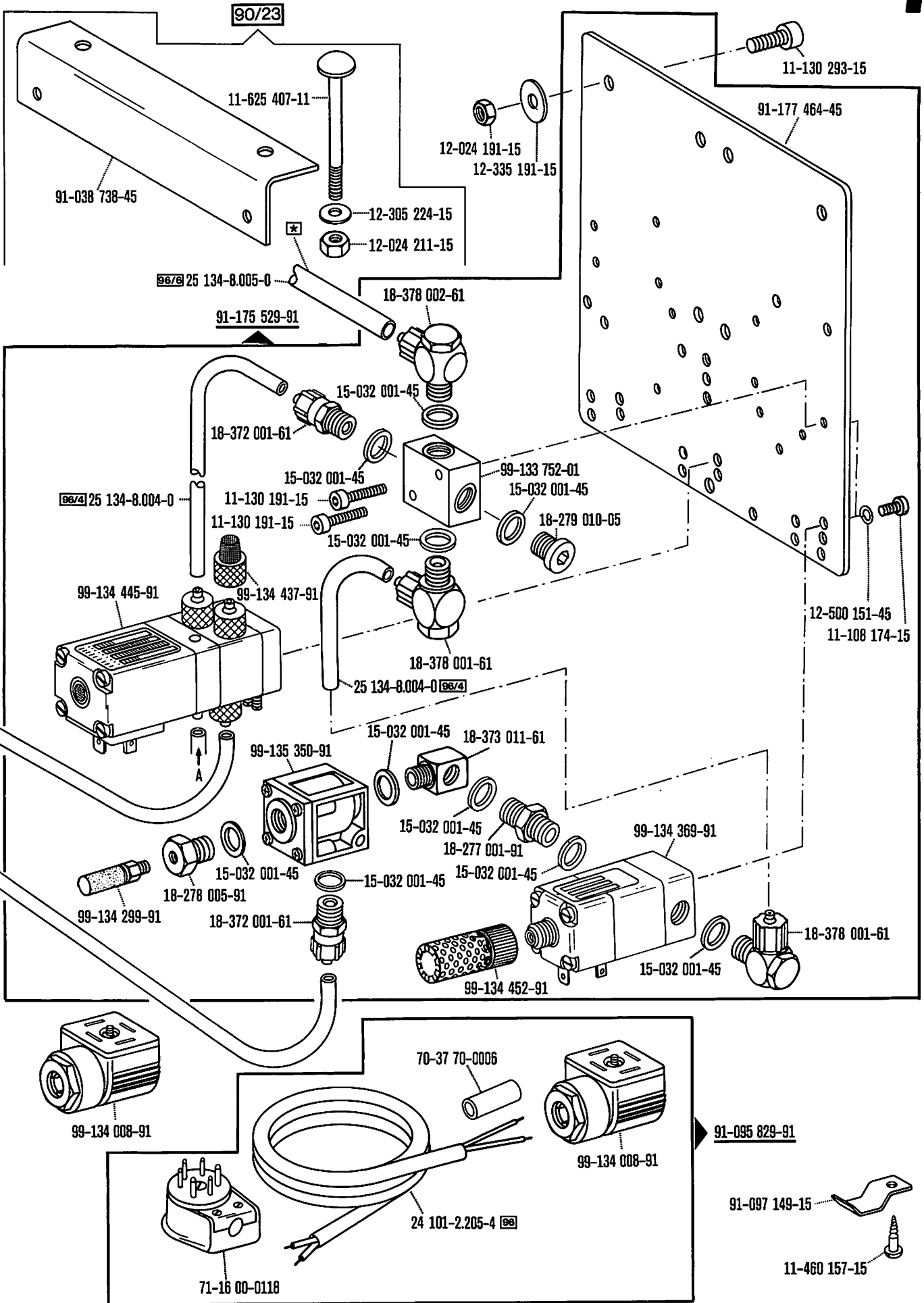

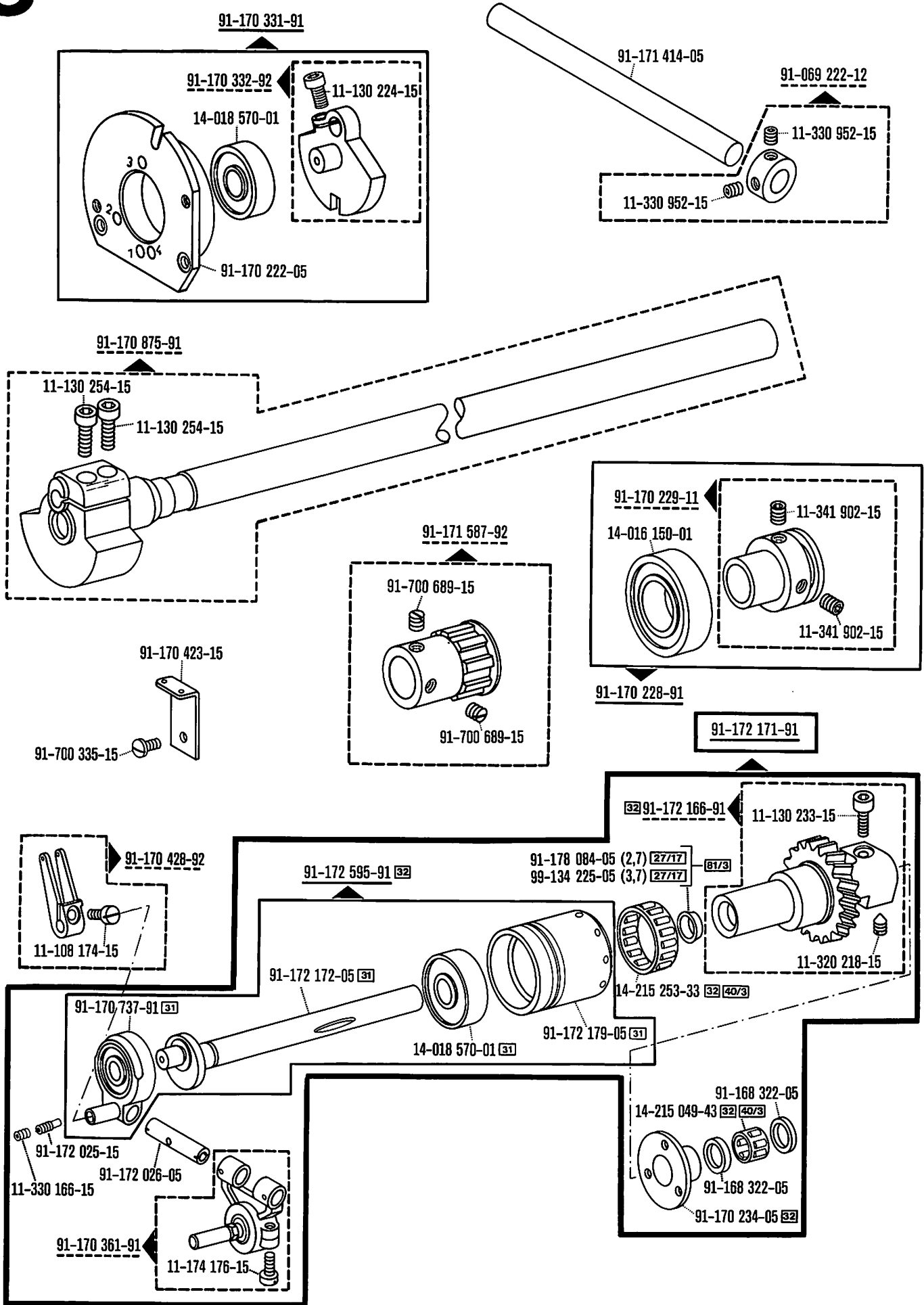

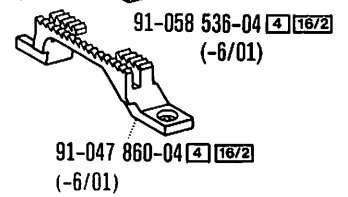
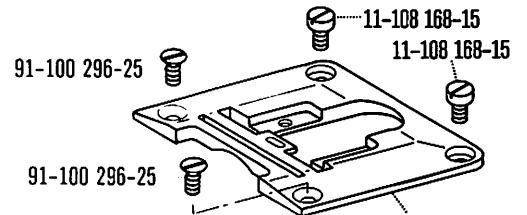
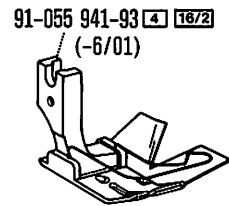
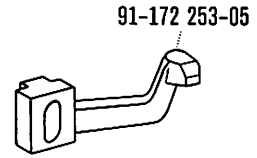
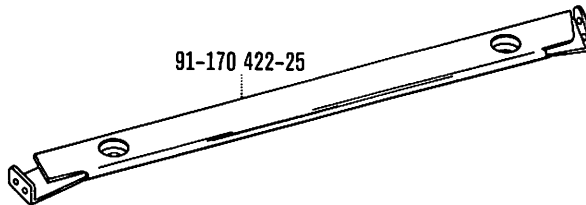
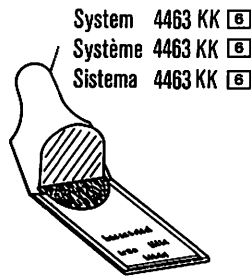
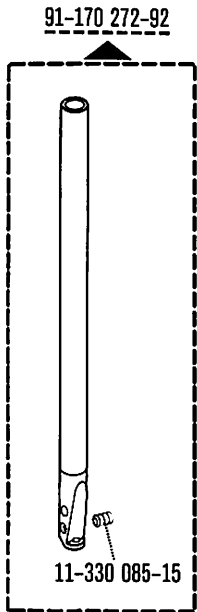

91-170 429-91

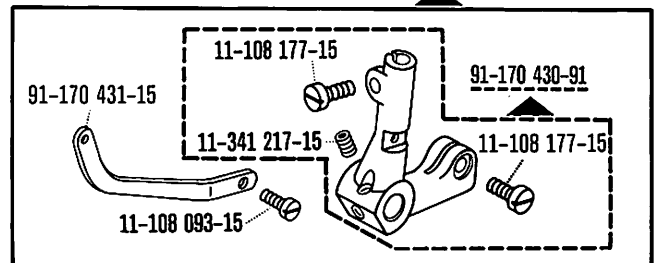
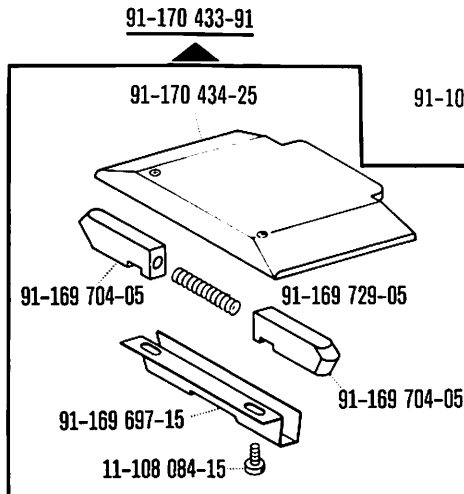
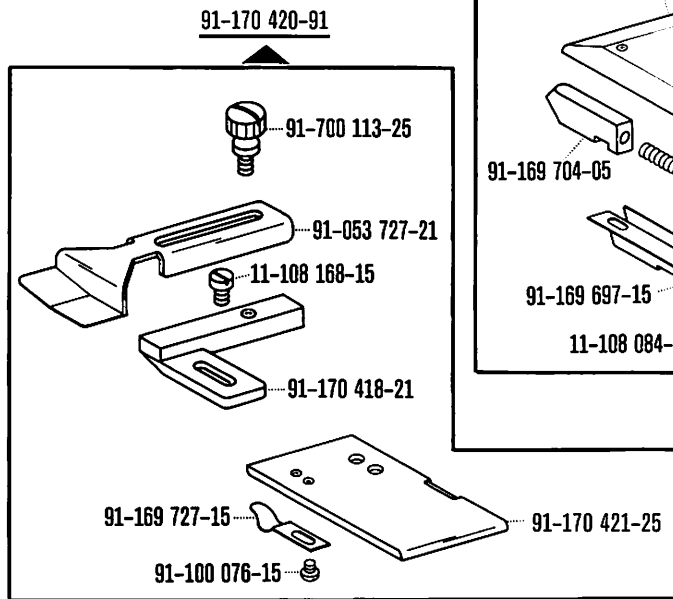

12-005 175-15 91-170 891-15

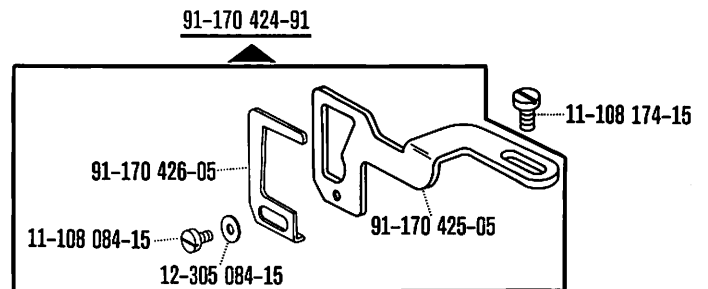
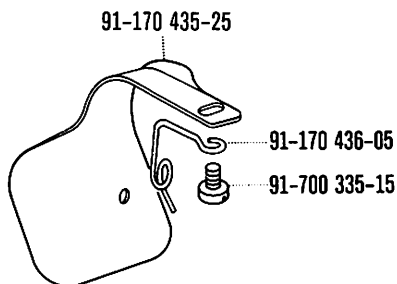

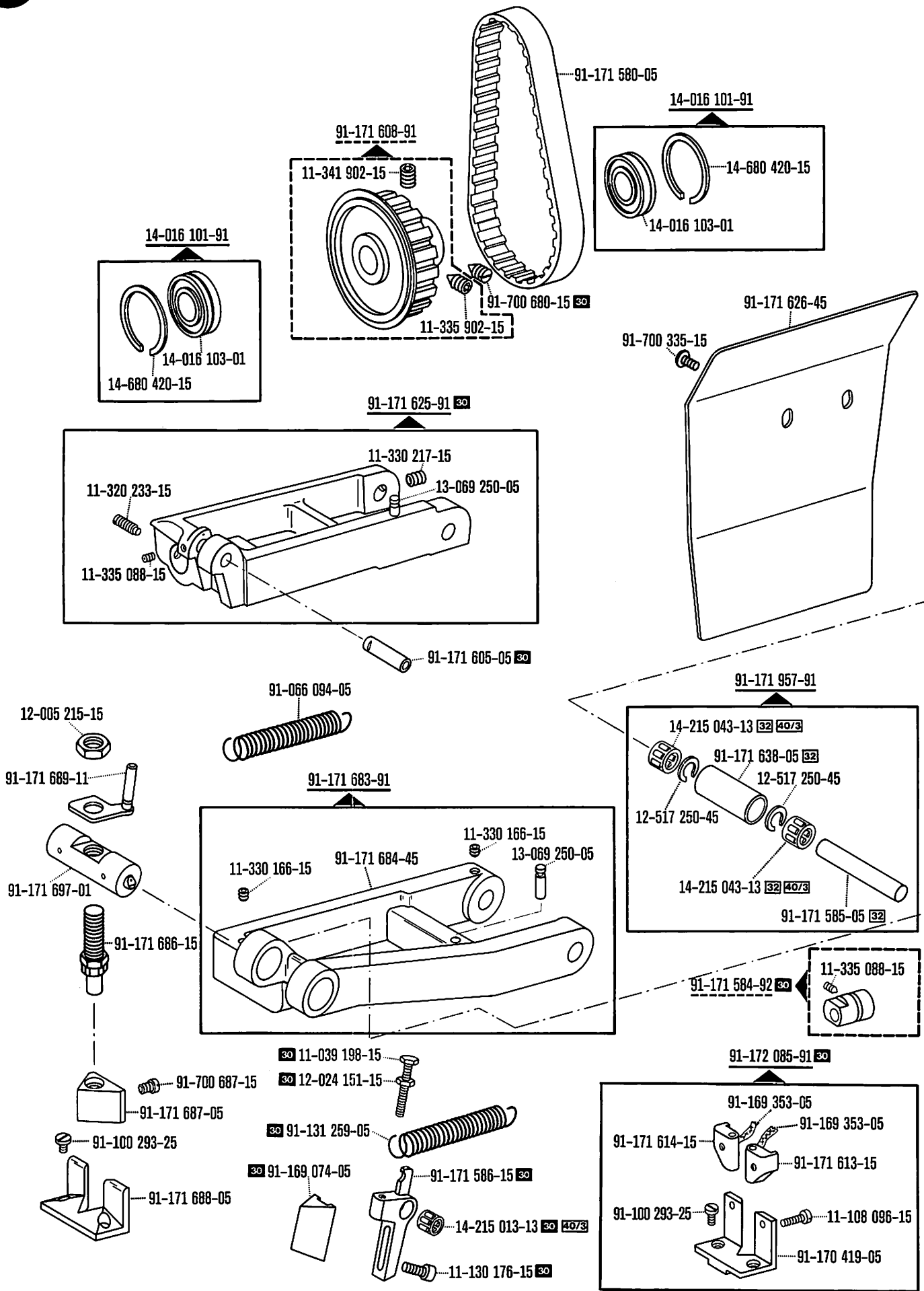

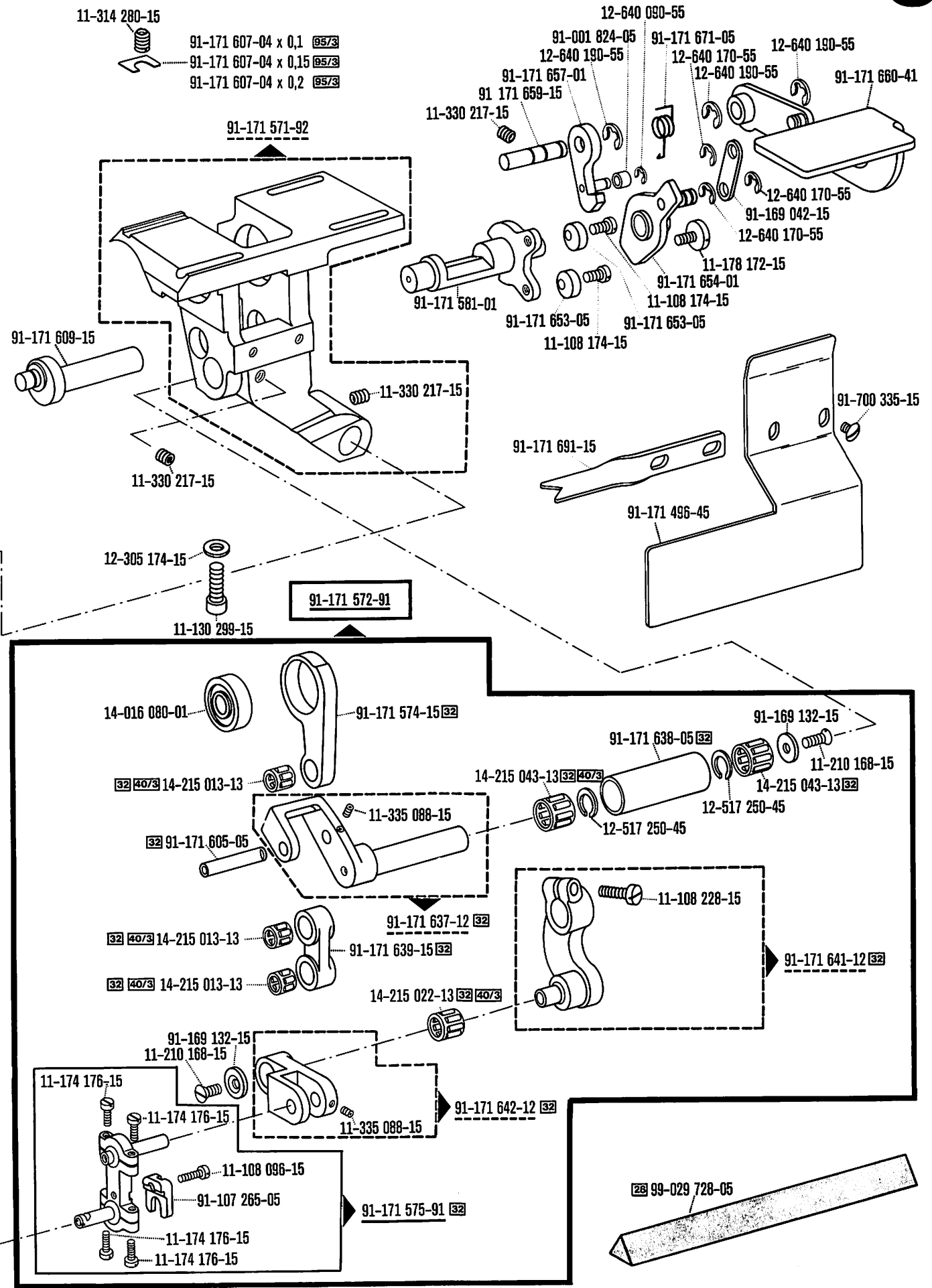

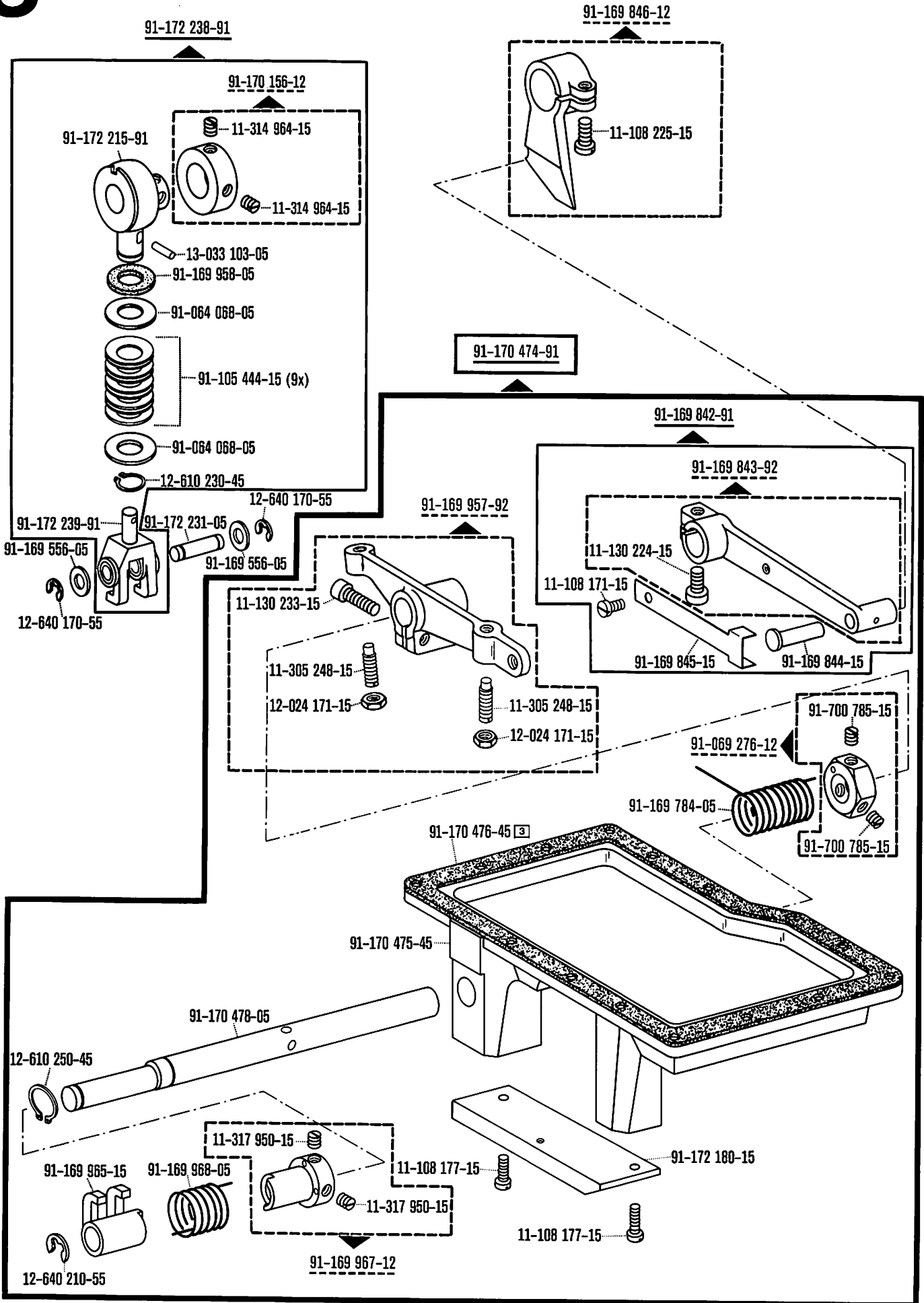

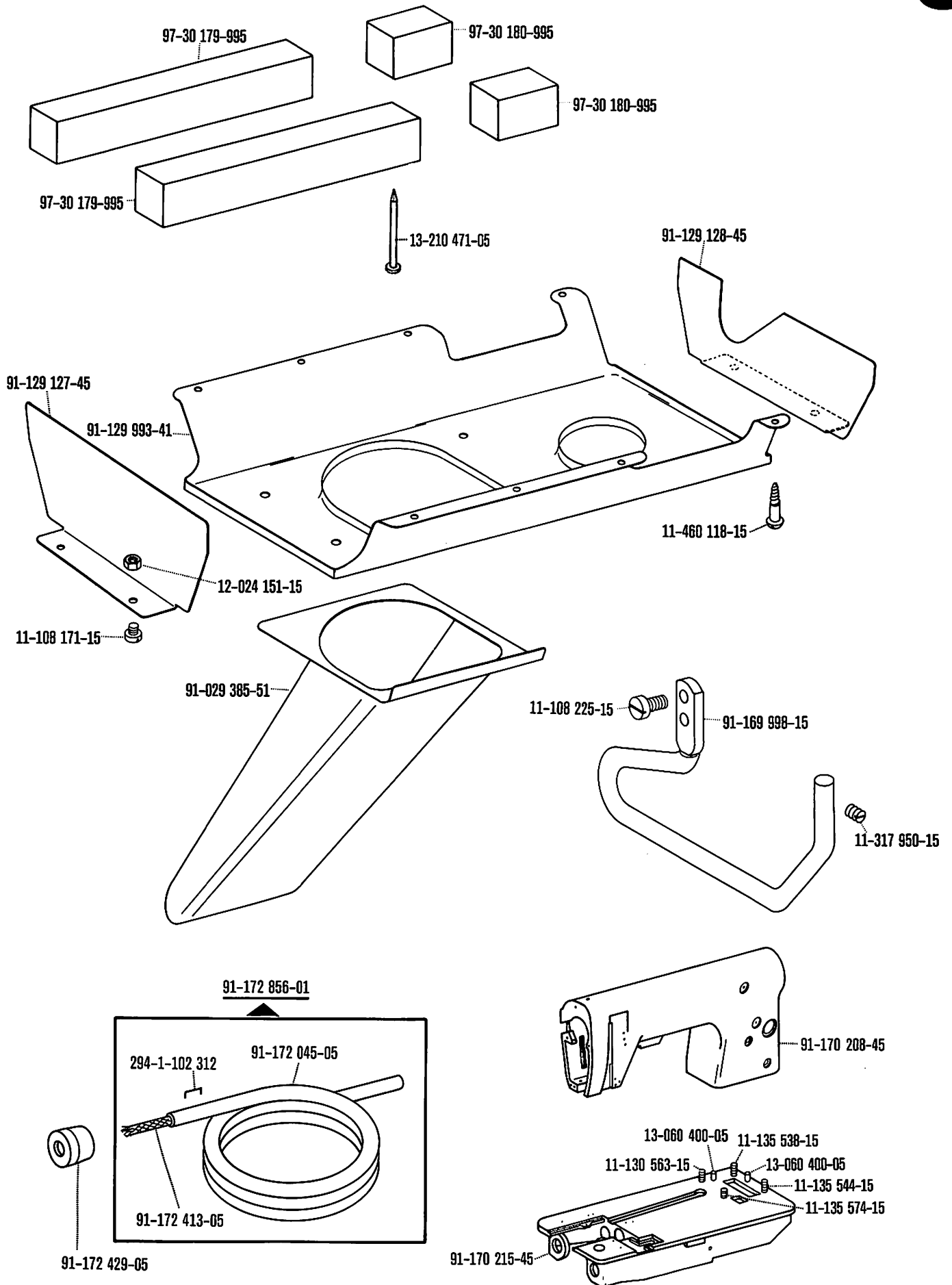

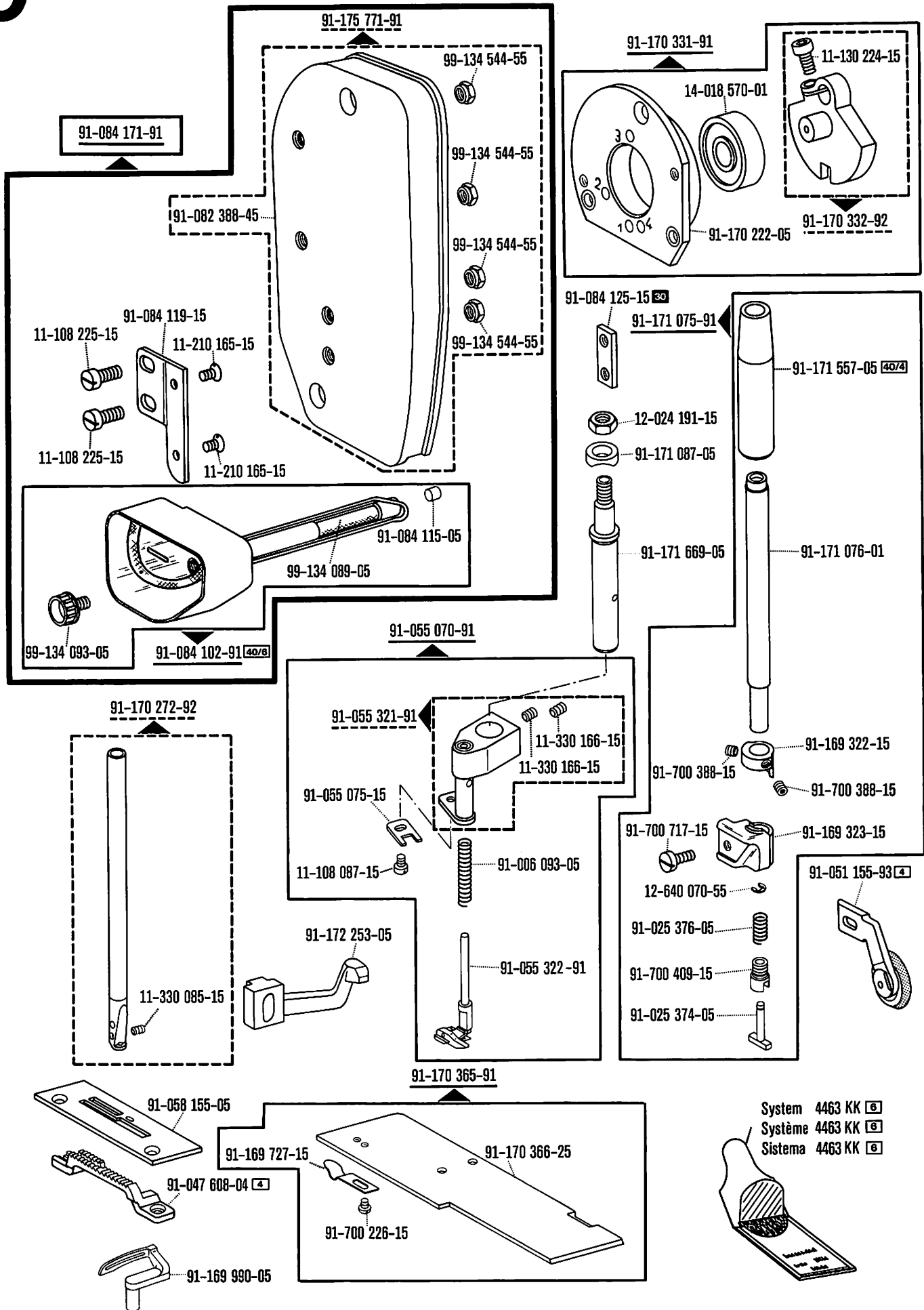





System 4463 KK 
 Système 4463 KK 
 Sistema 4463 KK 

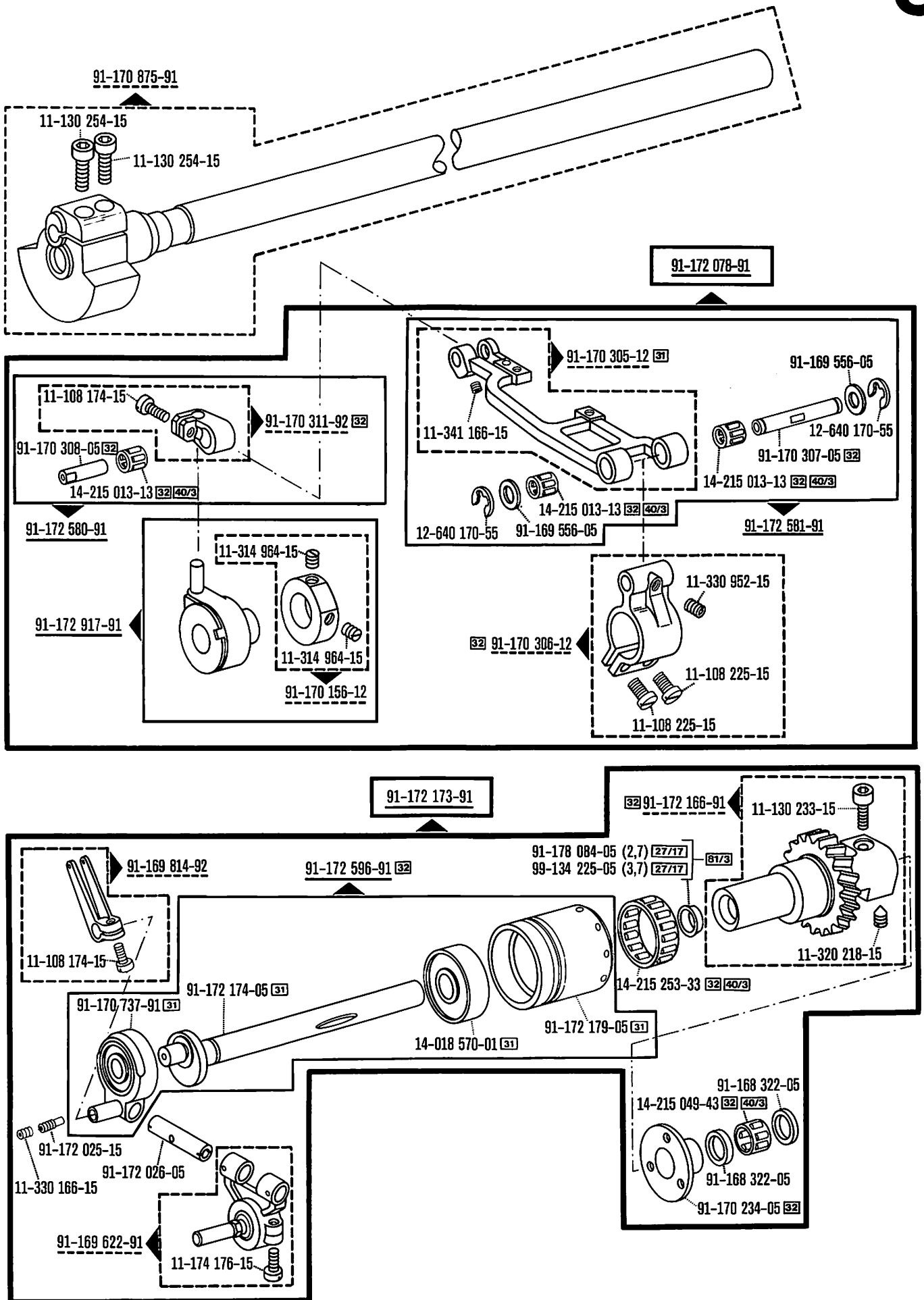

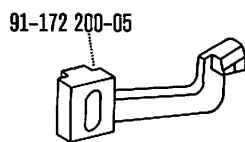
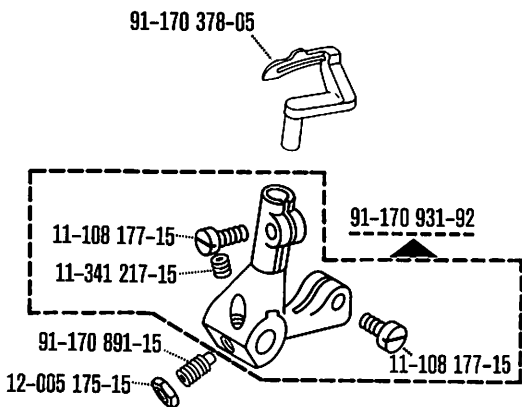
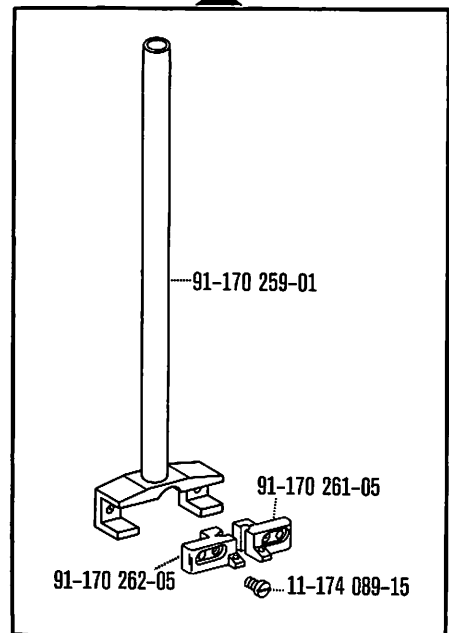
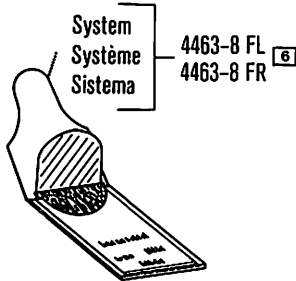
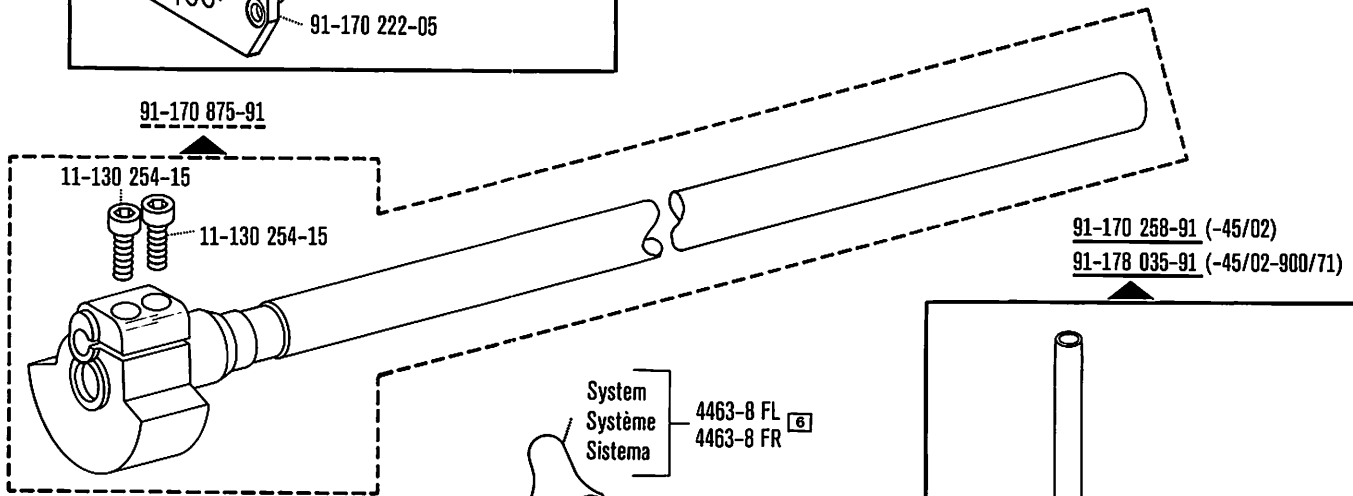
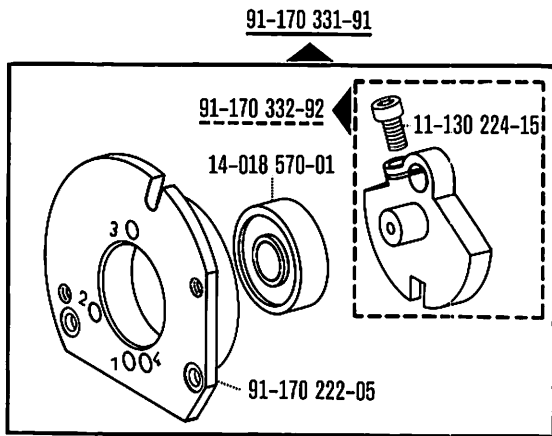
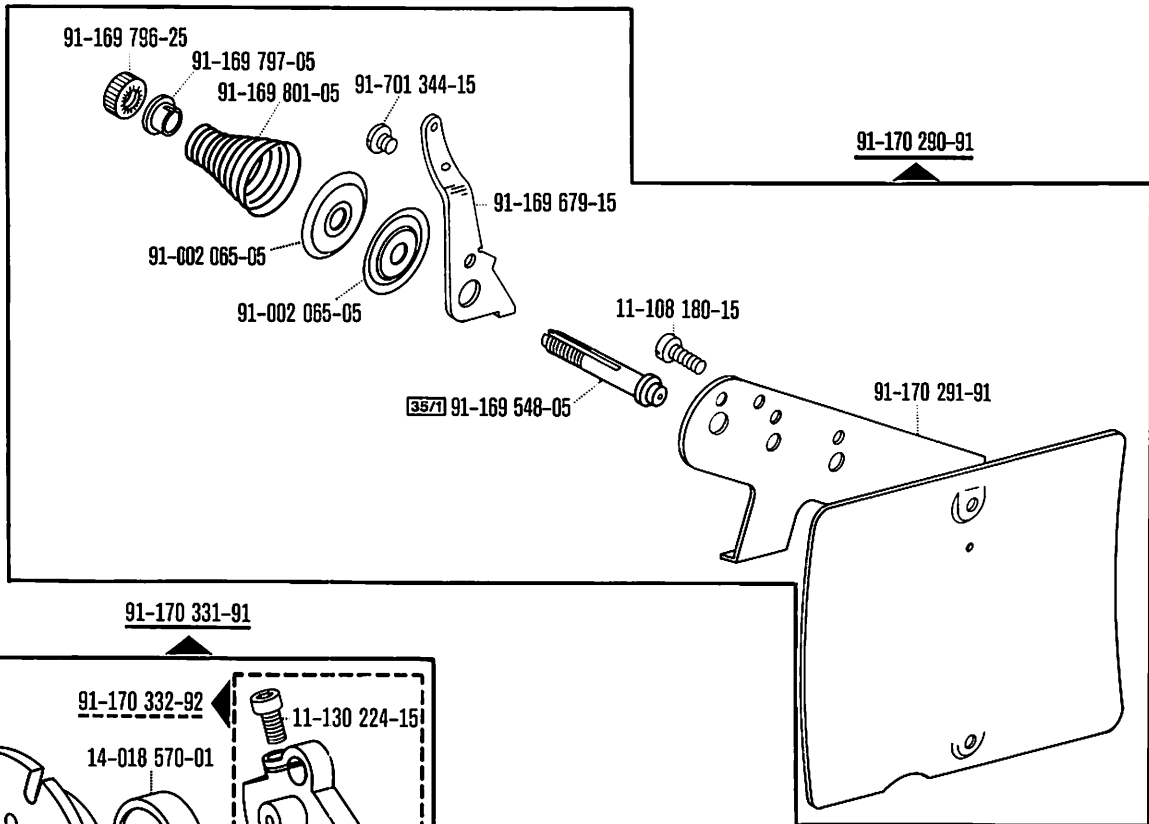

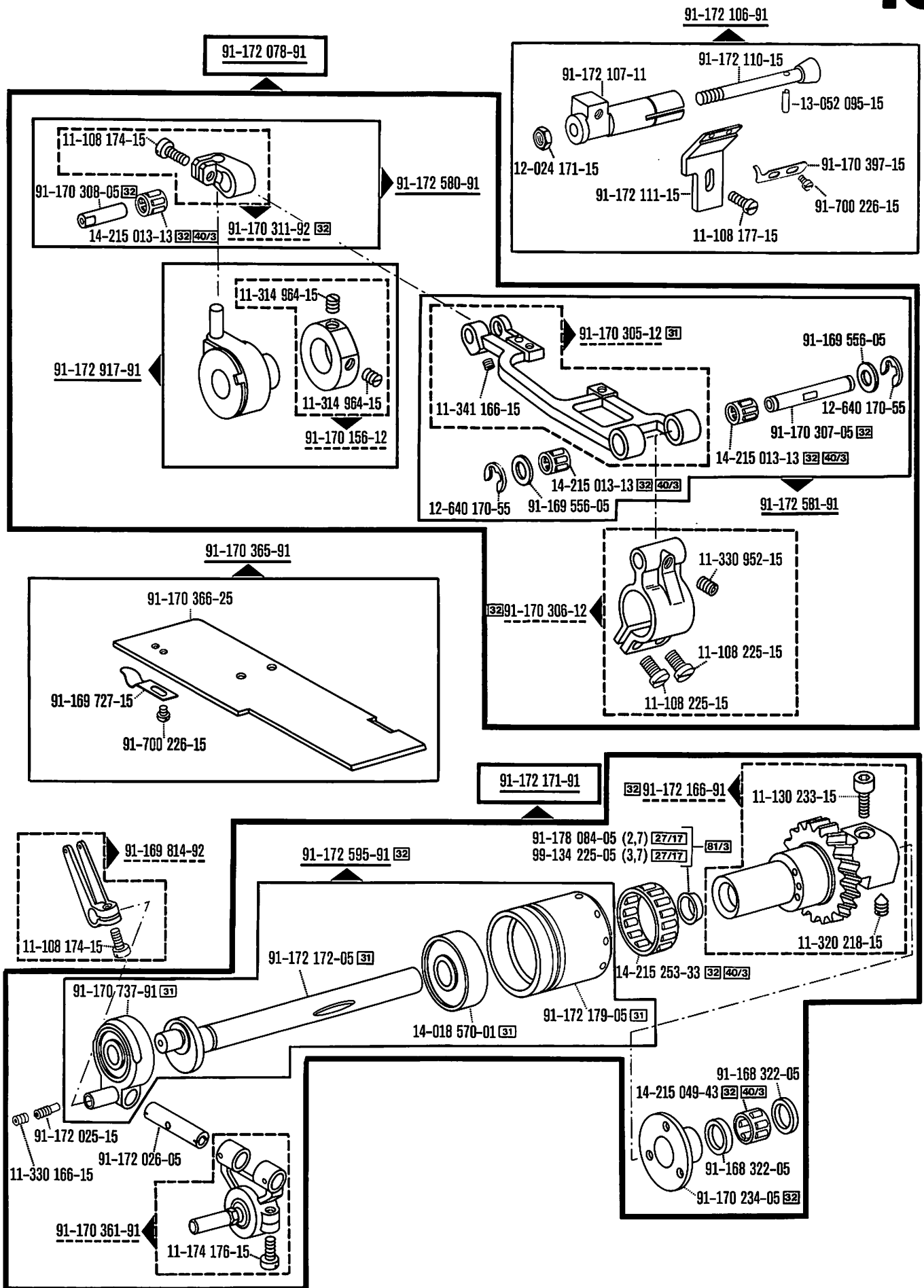

91-168 461-91 (-61/05)

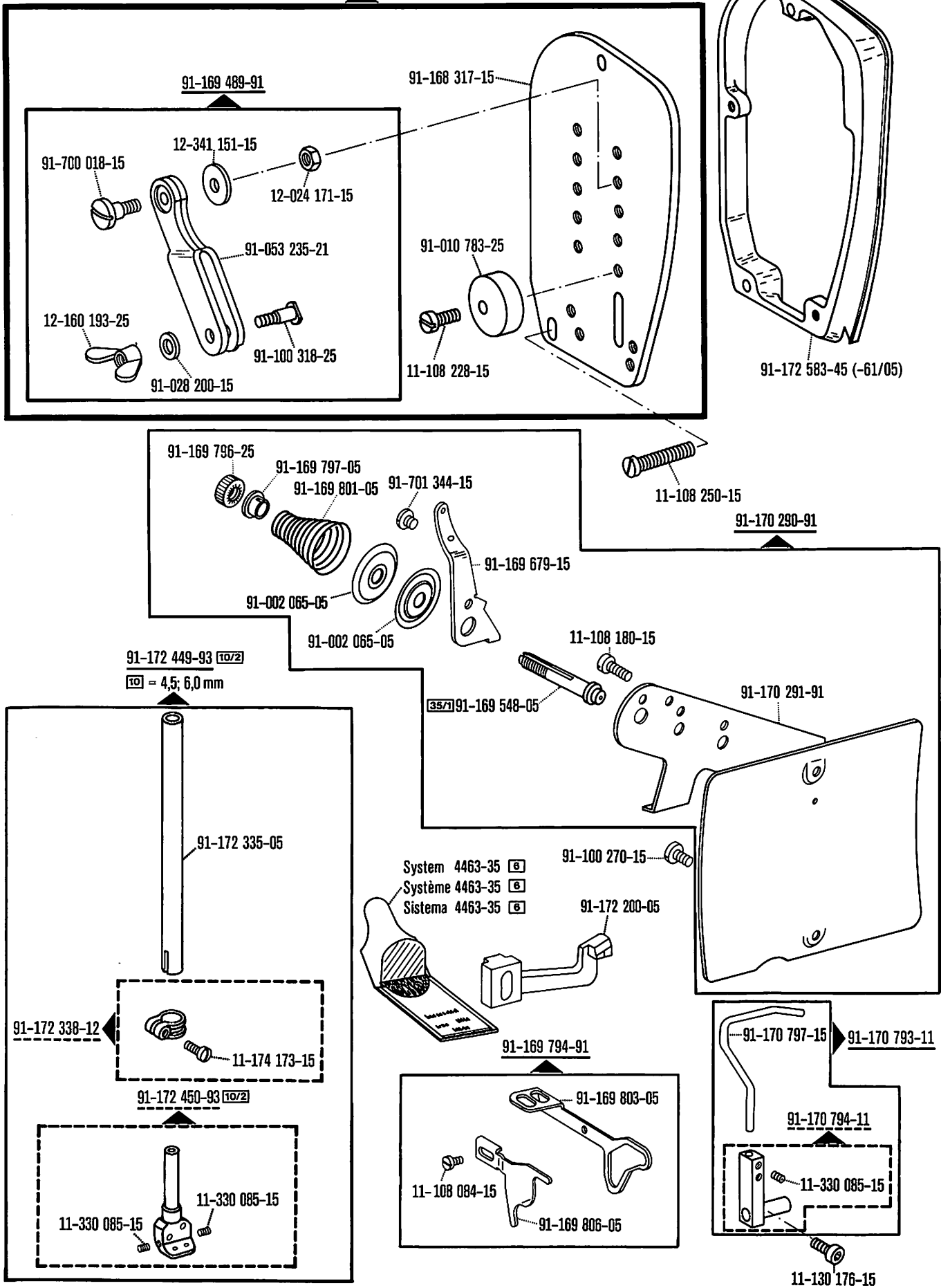

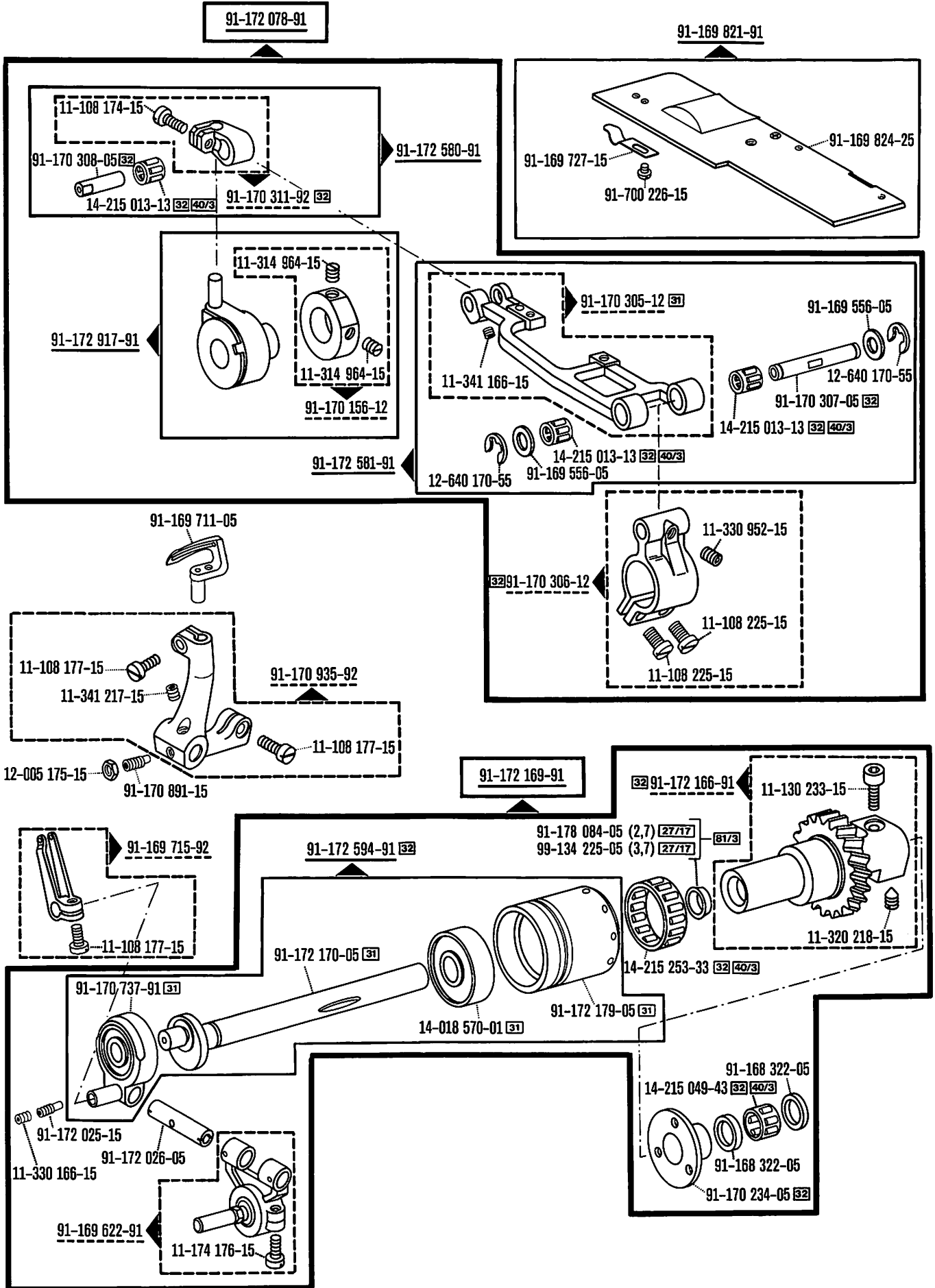

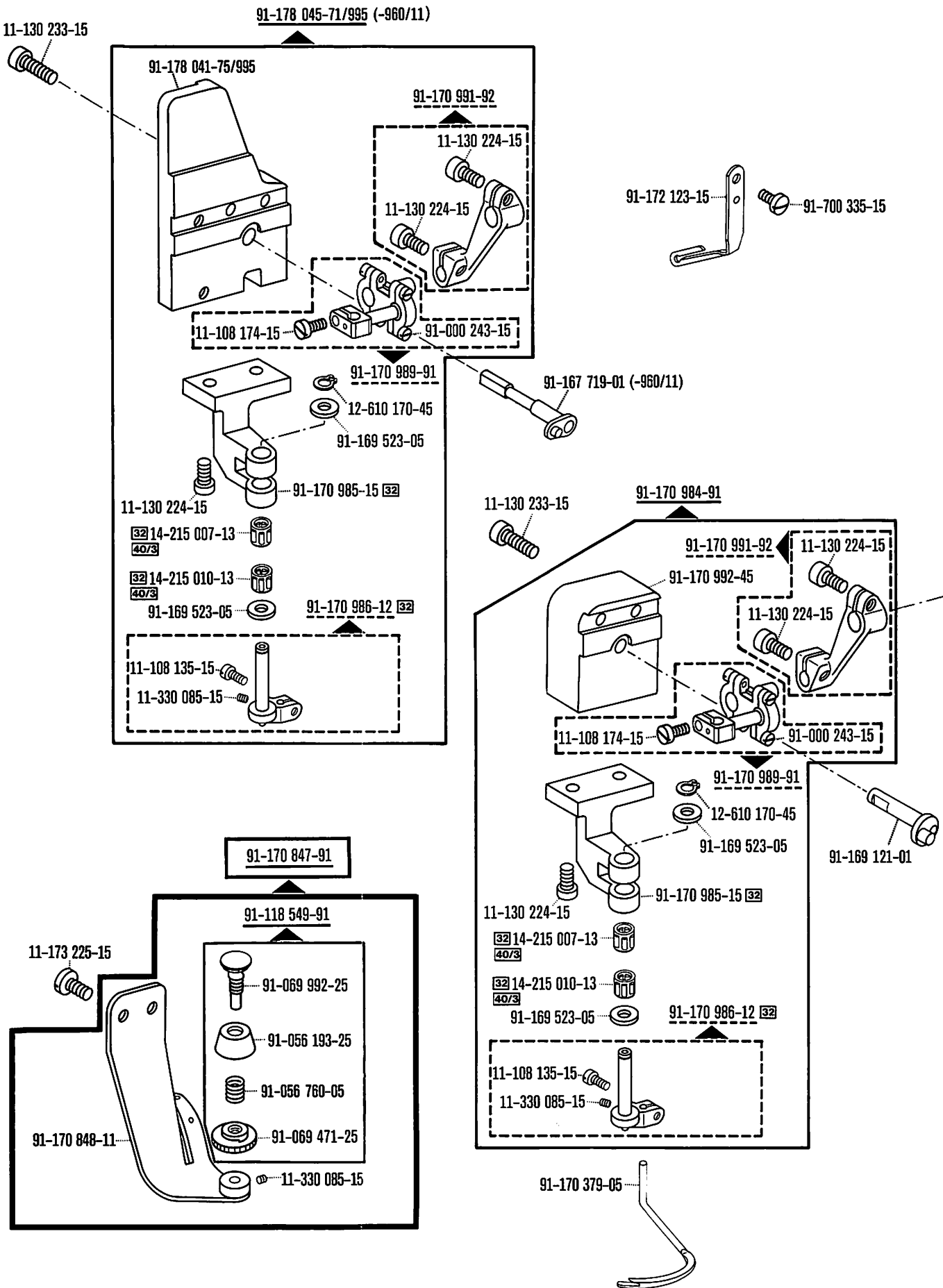

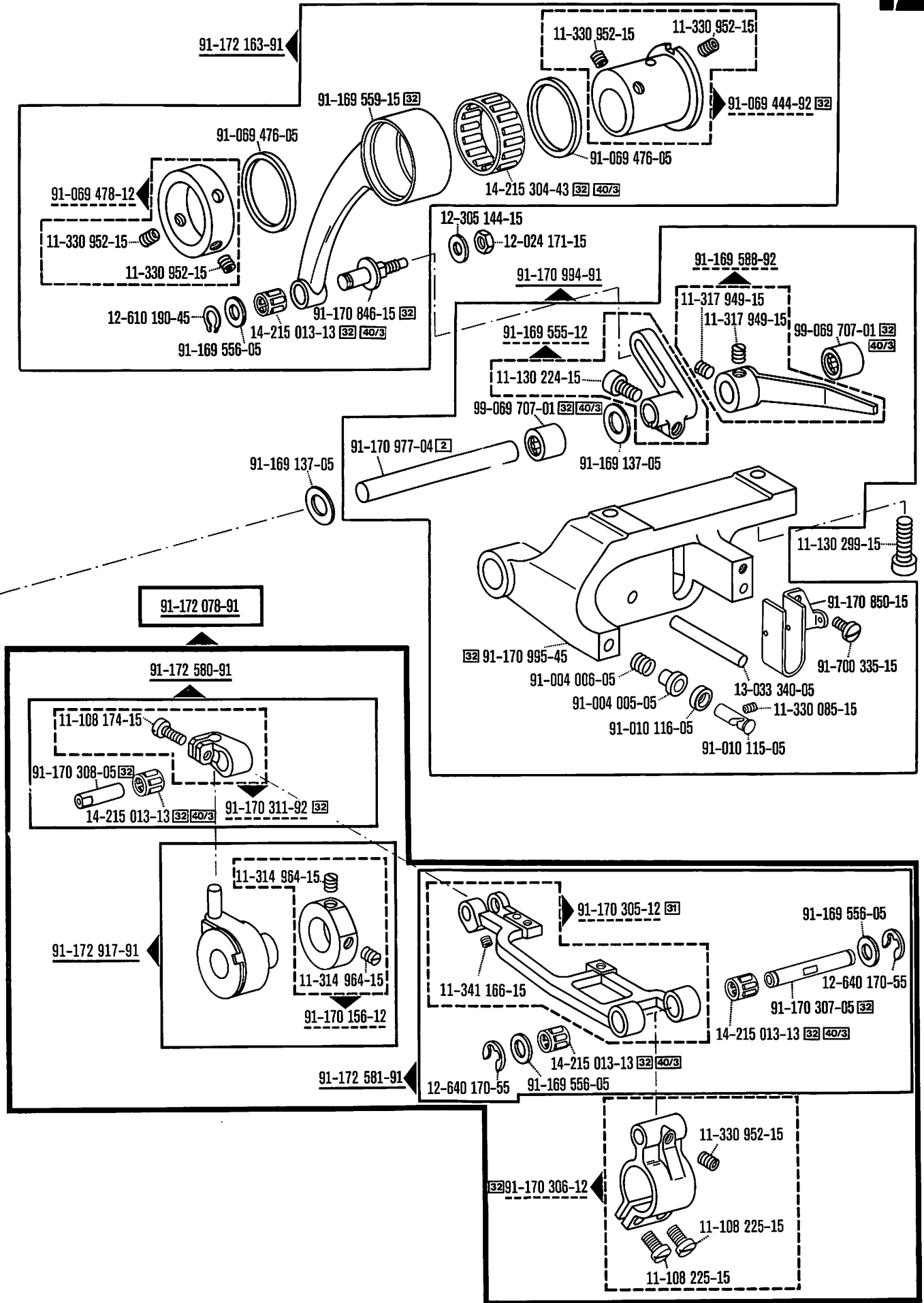

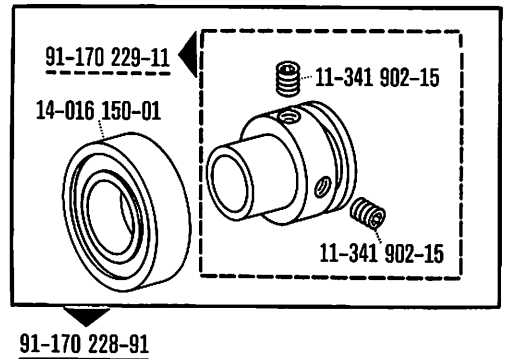
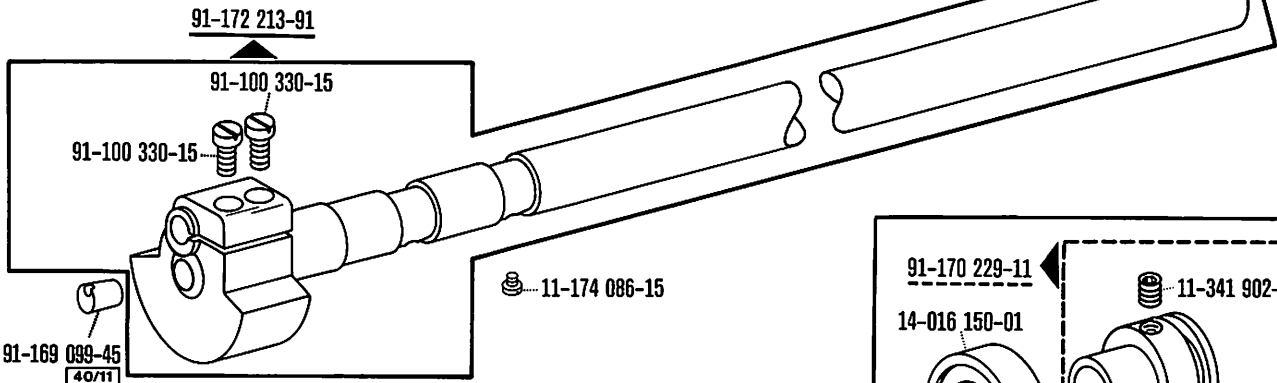
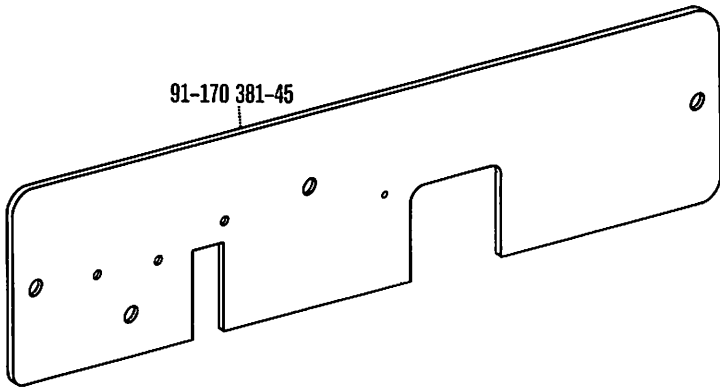
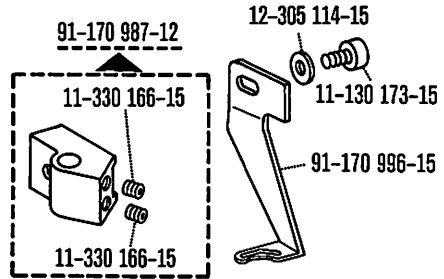
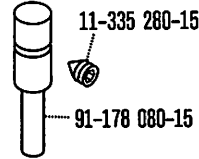
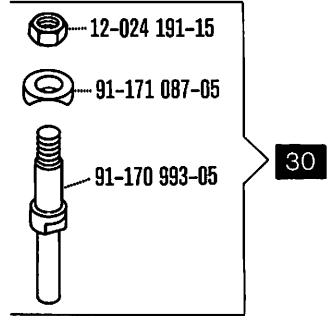
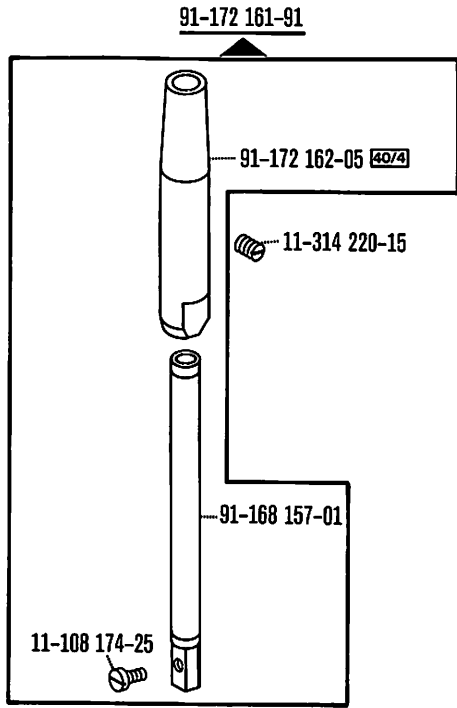

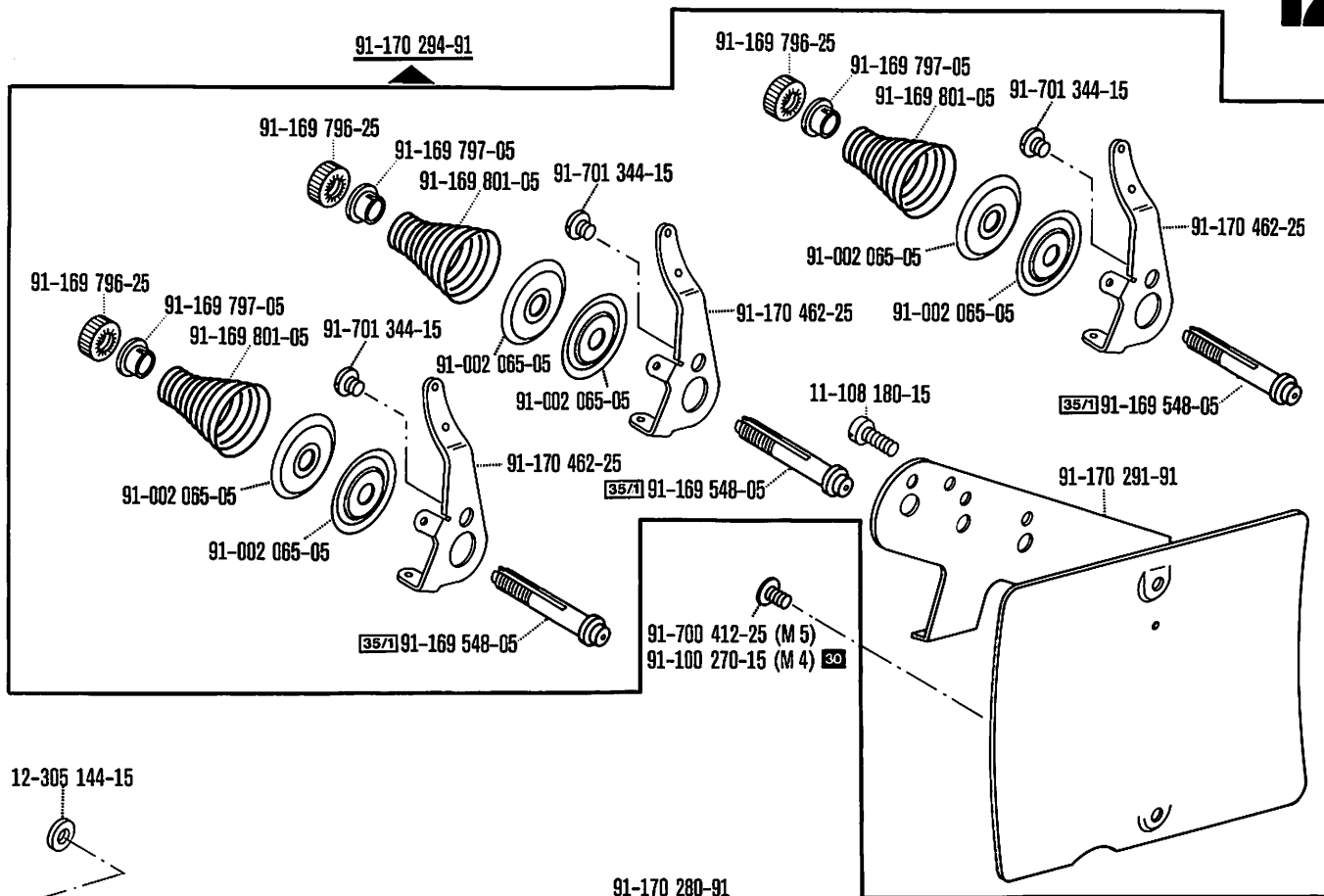

12-305 144-15

91-170 280-91

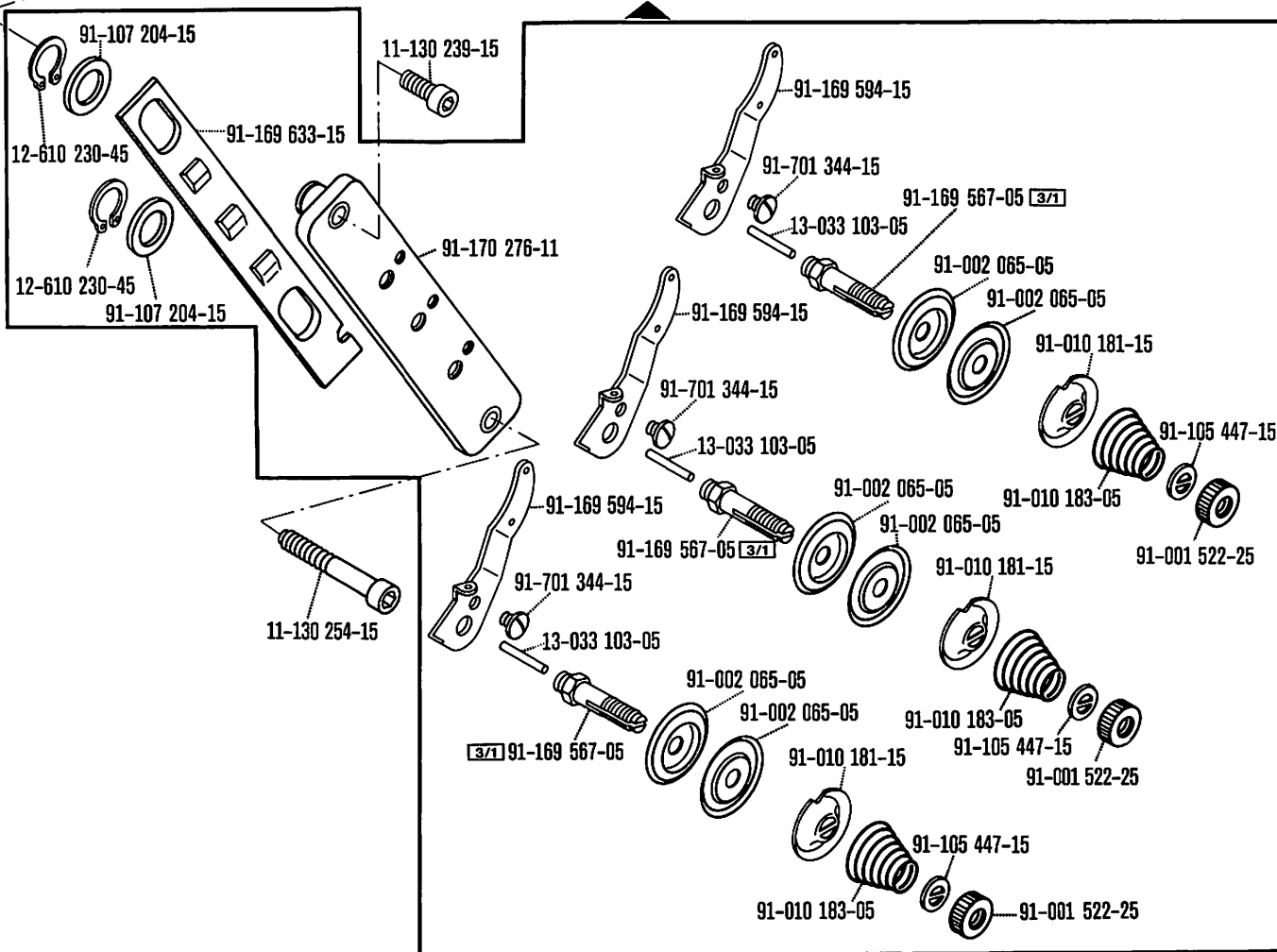

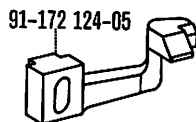
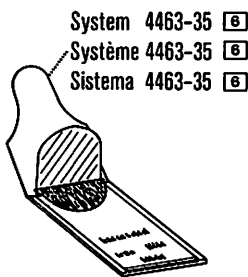
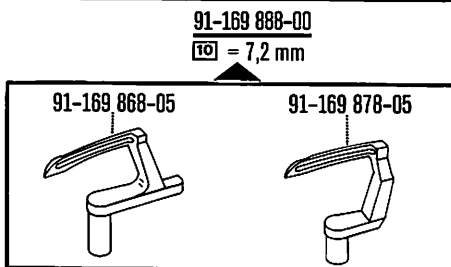
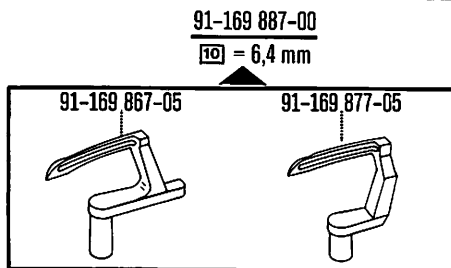
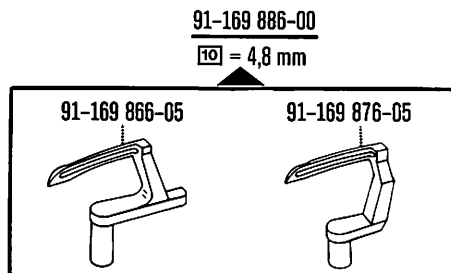
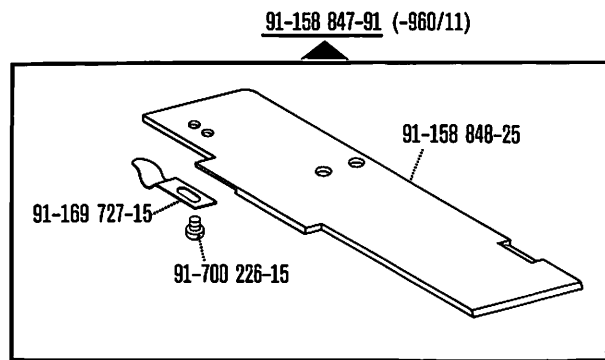
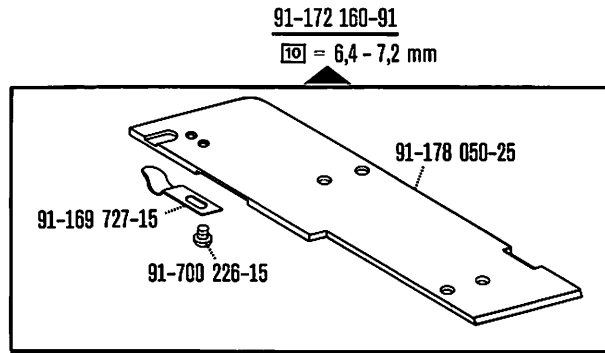
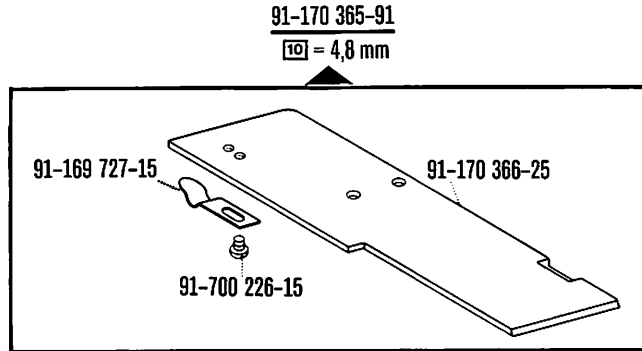
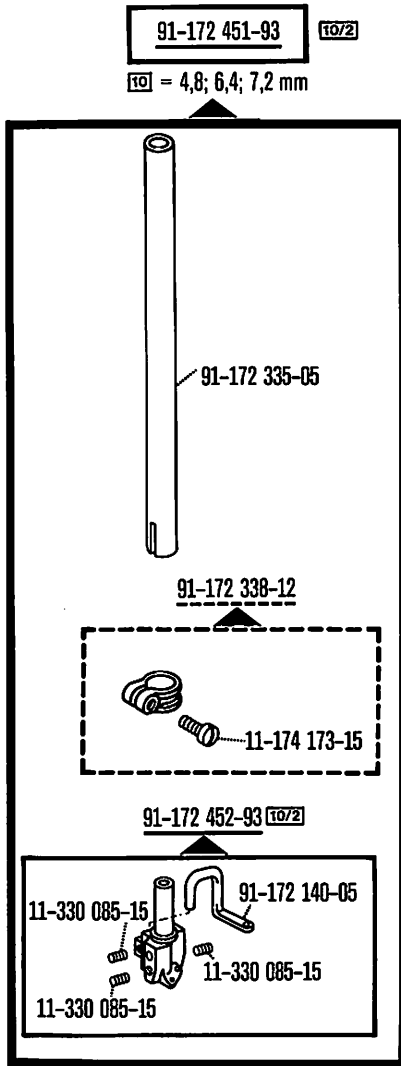

91-178 025-91

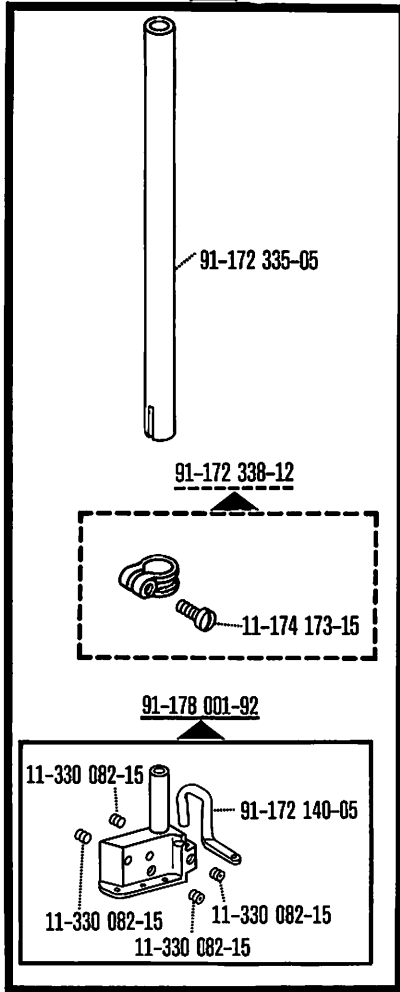

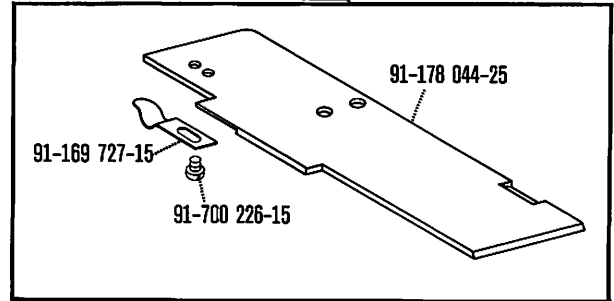

91-178 046-91

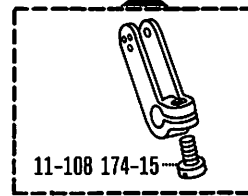

91-176 986-92





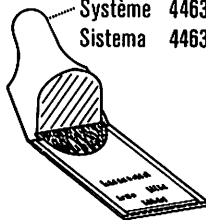

System 4463-35 
 Système 4463-35 
 Sistema 4463-35 

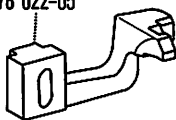

91-178 022-05



91-169 614-05 (0,5) 
 91-169 615-05 (0,8) 
 91-170 693-05 (0,3) 
 91-170 694-05 (1,2) 

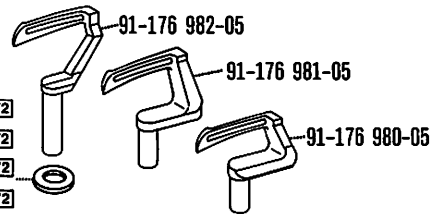

91-178 021-92

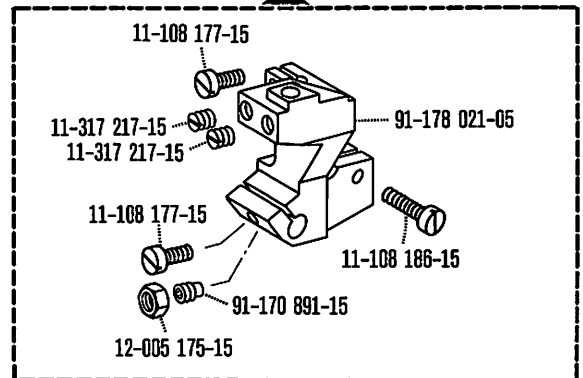

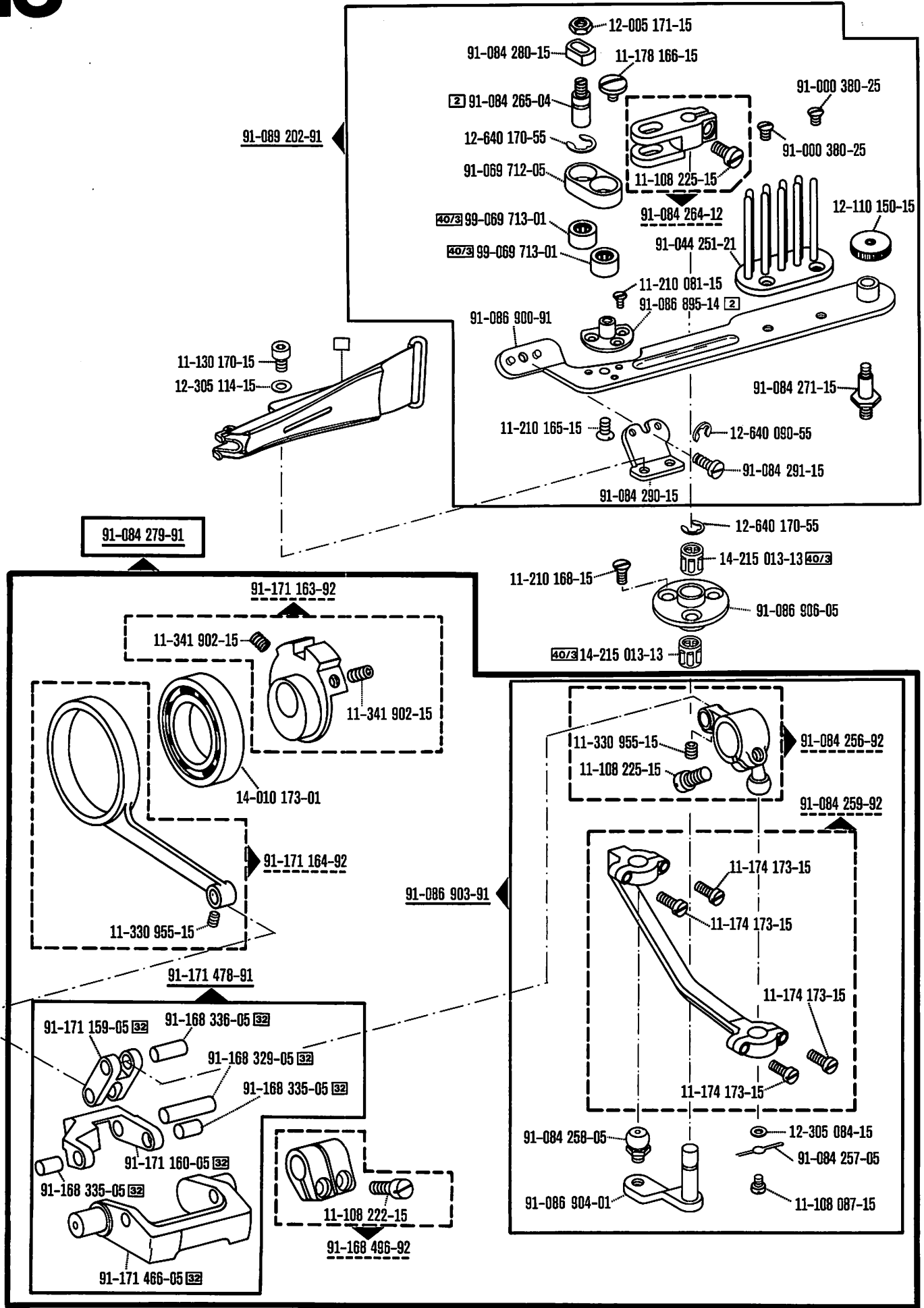

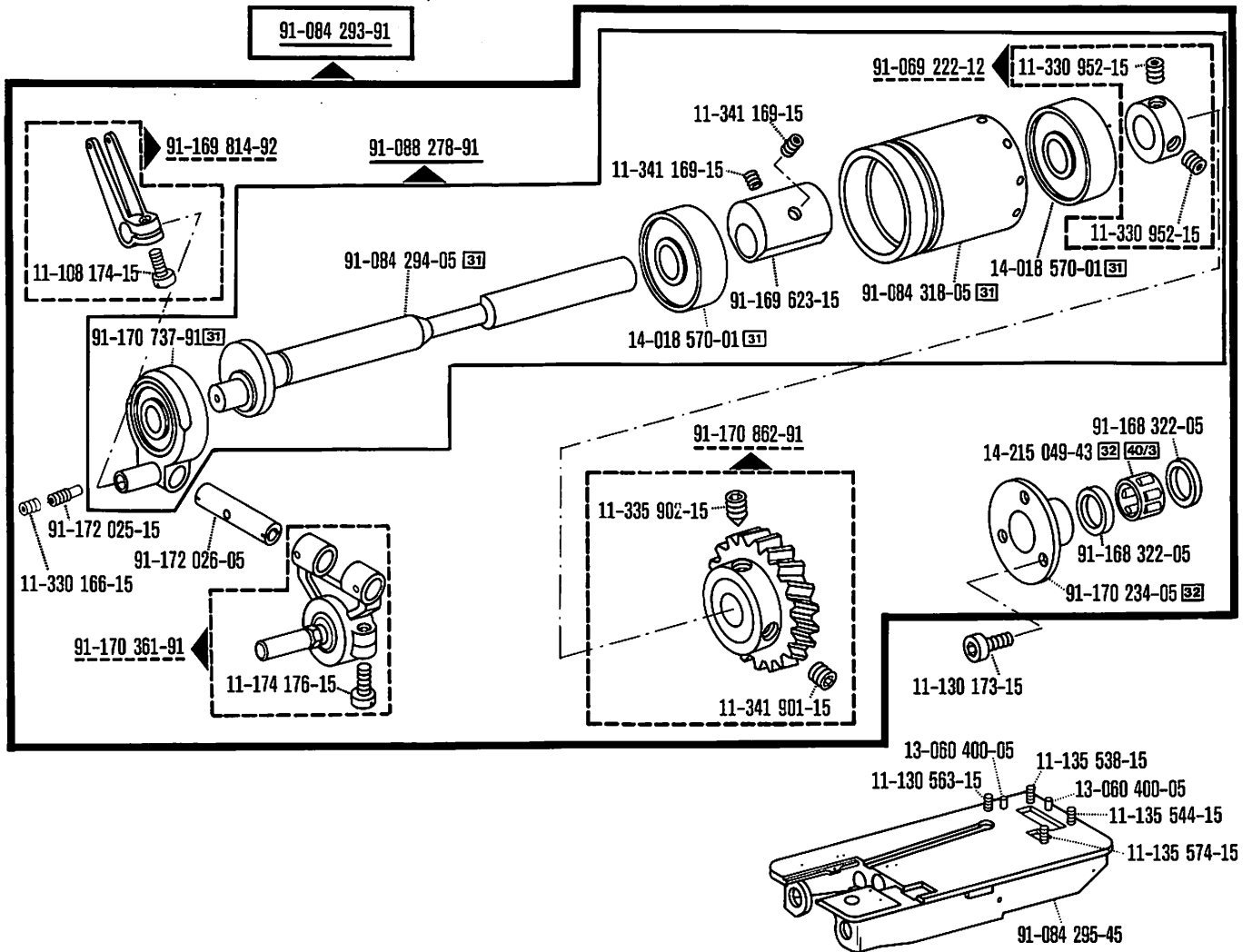

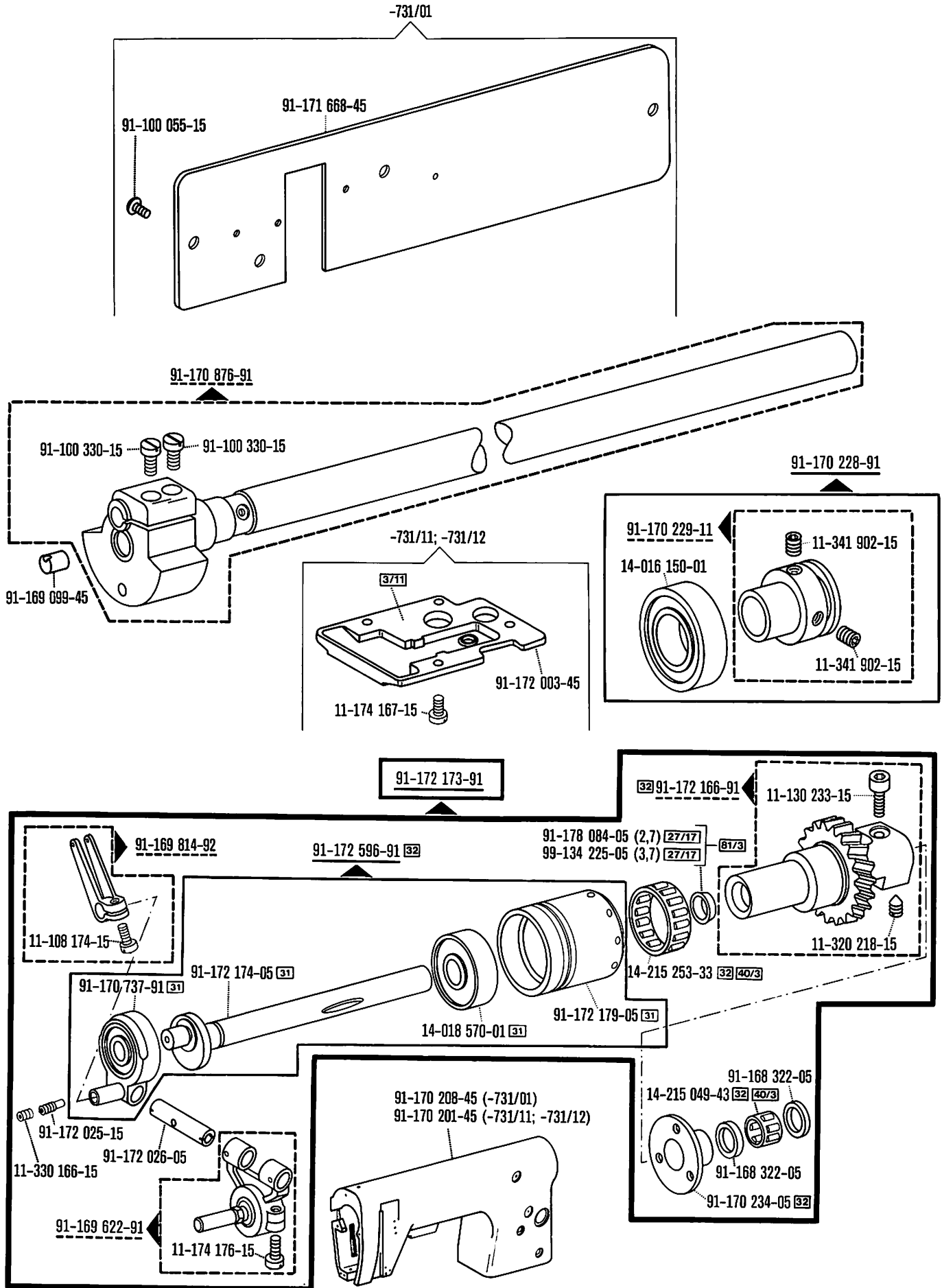

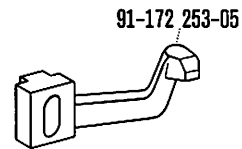
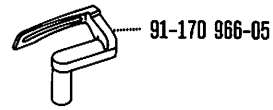
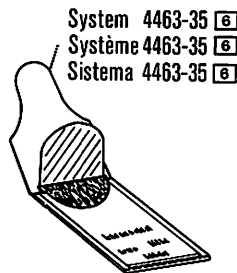
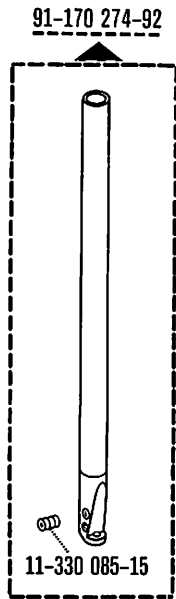

91-170 410-9 ^{9/2}

⁹ = 2,5-3,0 mm

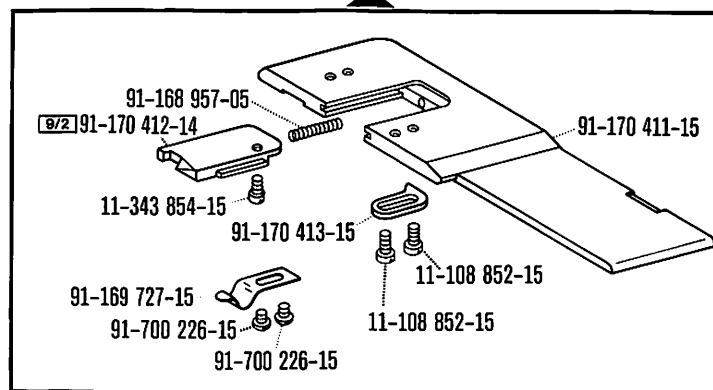

91-170 270-93 ^{9/2}

⁹ = 3,5-10,0 mm

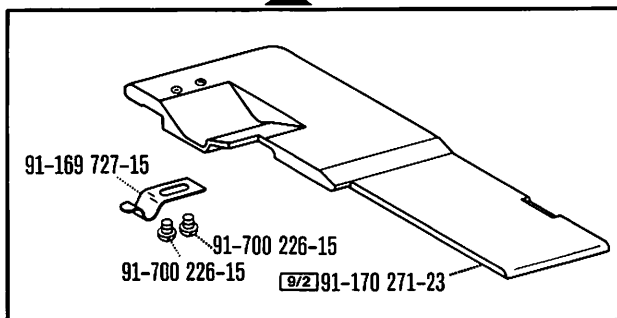



91-178 096-93 ^{9/2} (-900/51; /71)

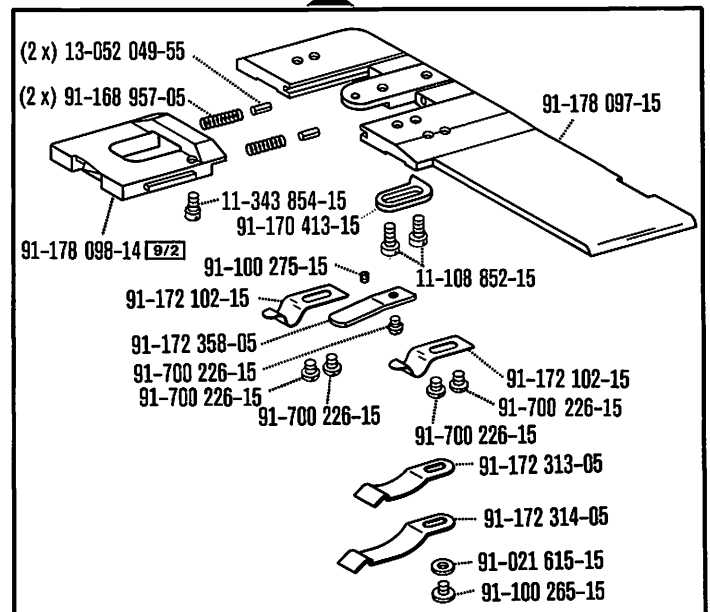

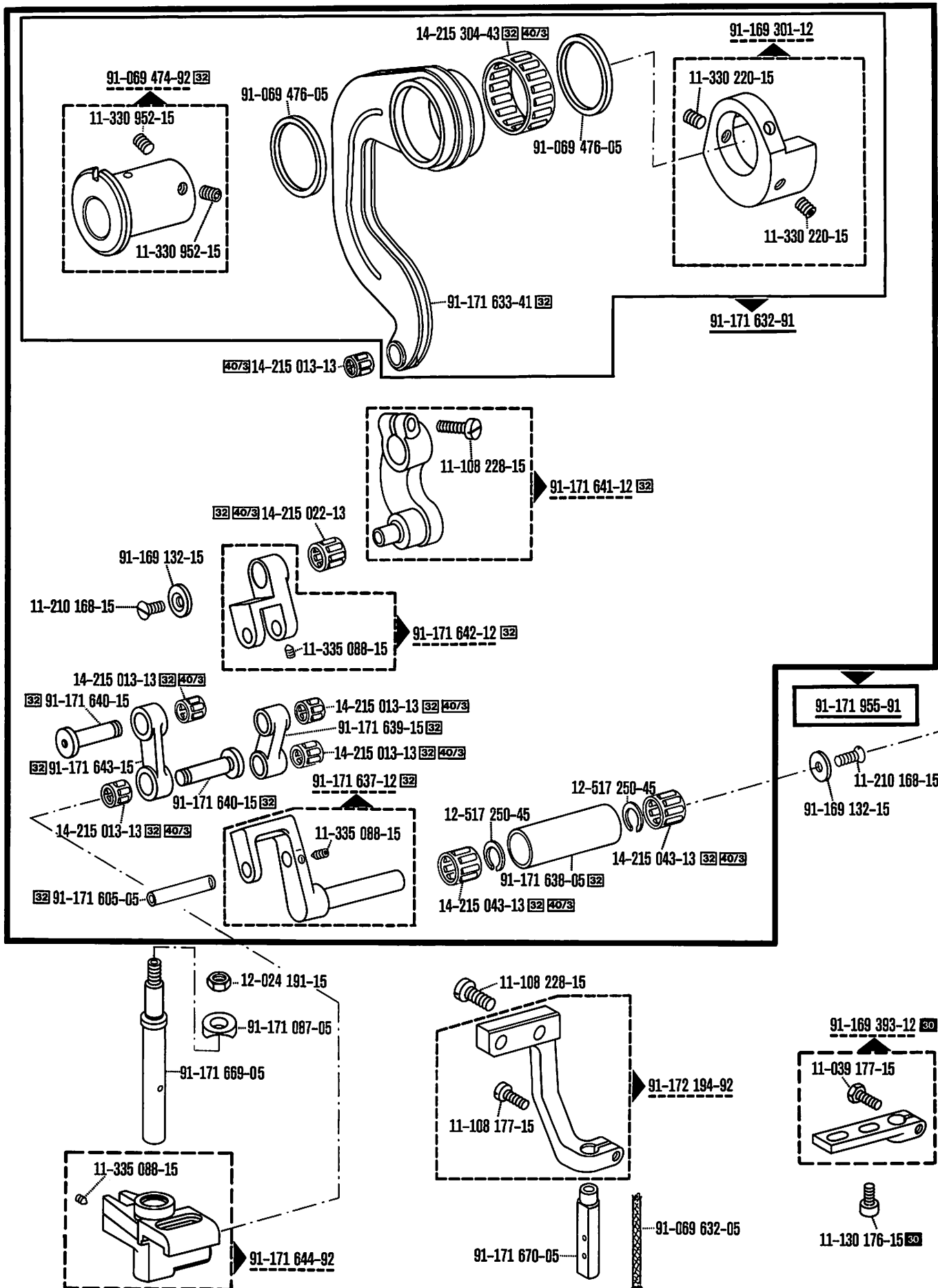
⁹ = 2,5 - 10,0 mm

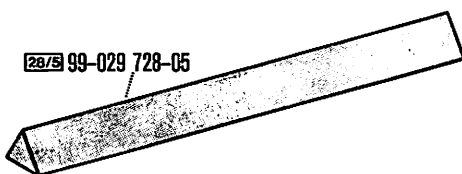
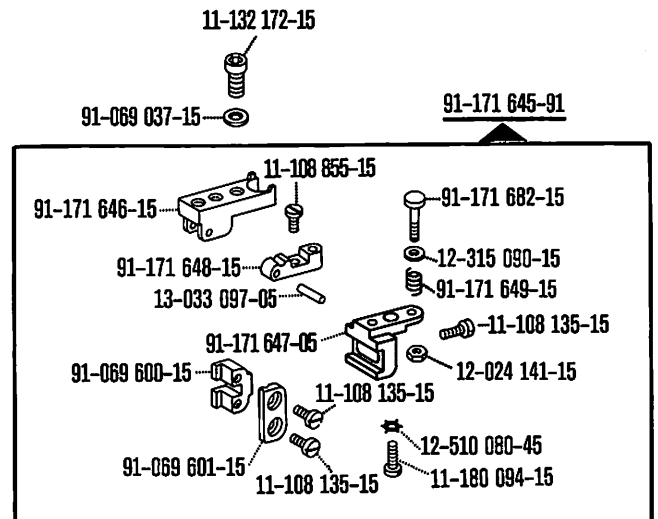
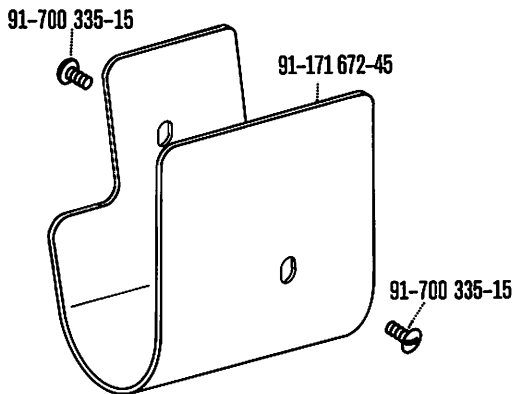
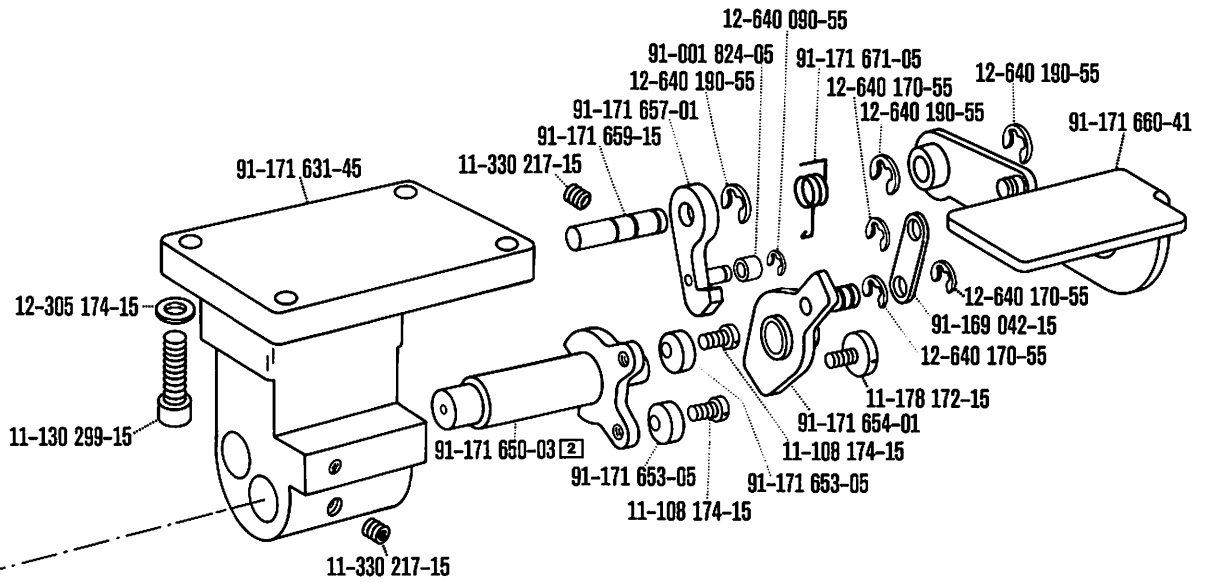





91-169 395-04 x 7 
 = 2,5 - 6,0 mm

91-170 560-04 x 9 
 = 7,0 - 10,0 mm

14

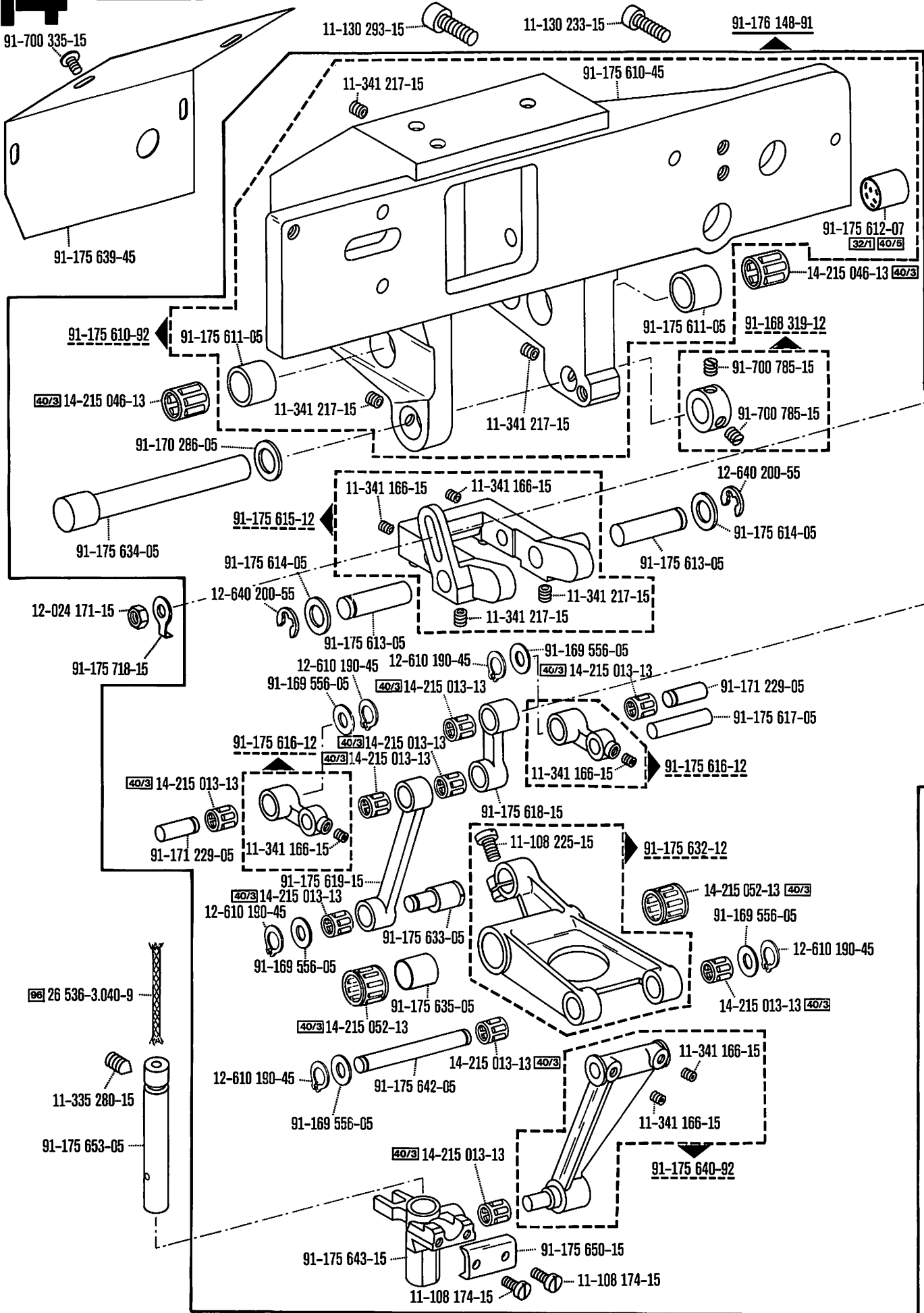

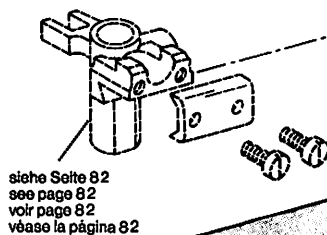
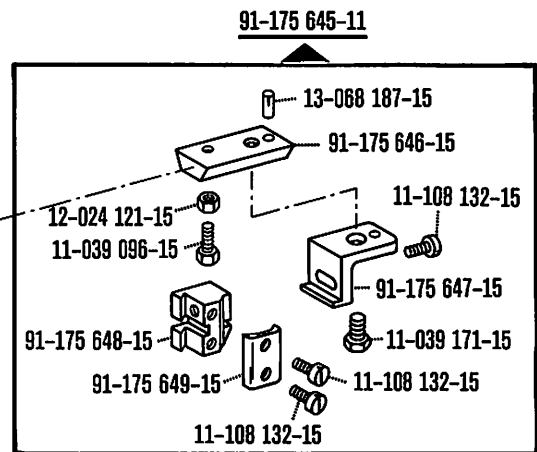
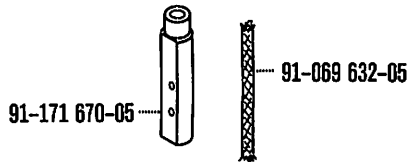
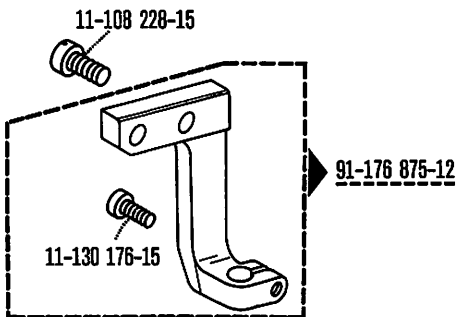
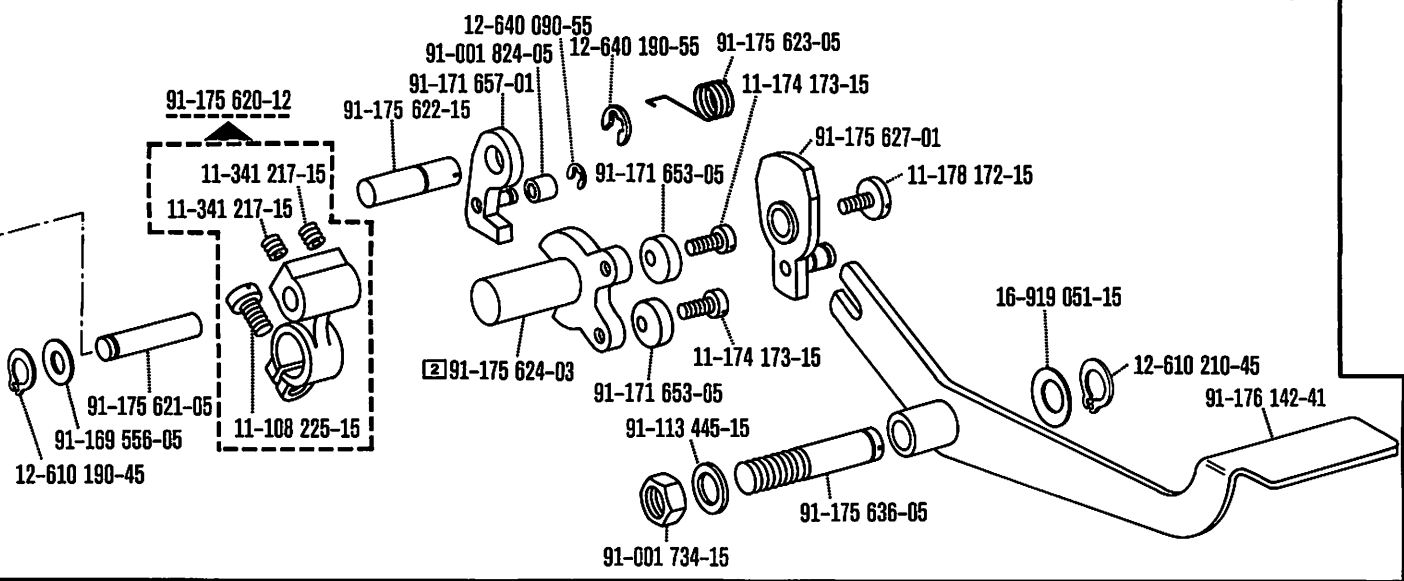
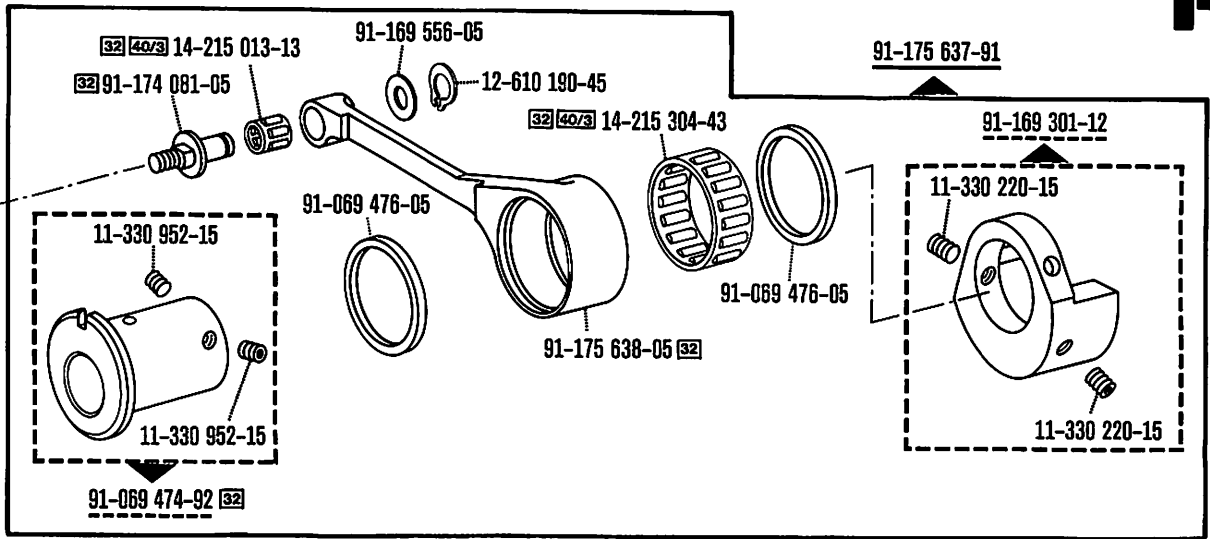

siehe Seite 82
see page 82
voir page 82
véase la página 82

91-169 395-04 x 7 $\frac{95}{2}$
= 2,5 - 6,0 mm

91-170 560-04 x 9 $\frac{95}{2}$
= 7,0 - 10,0 mm

14

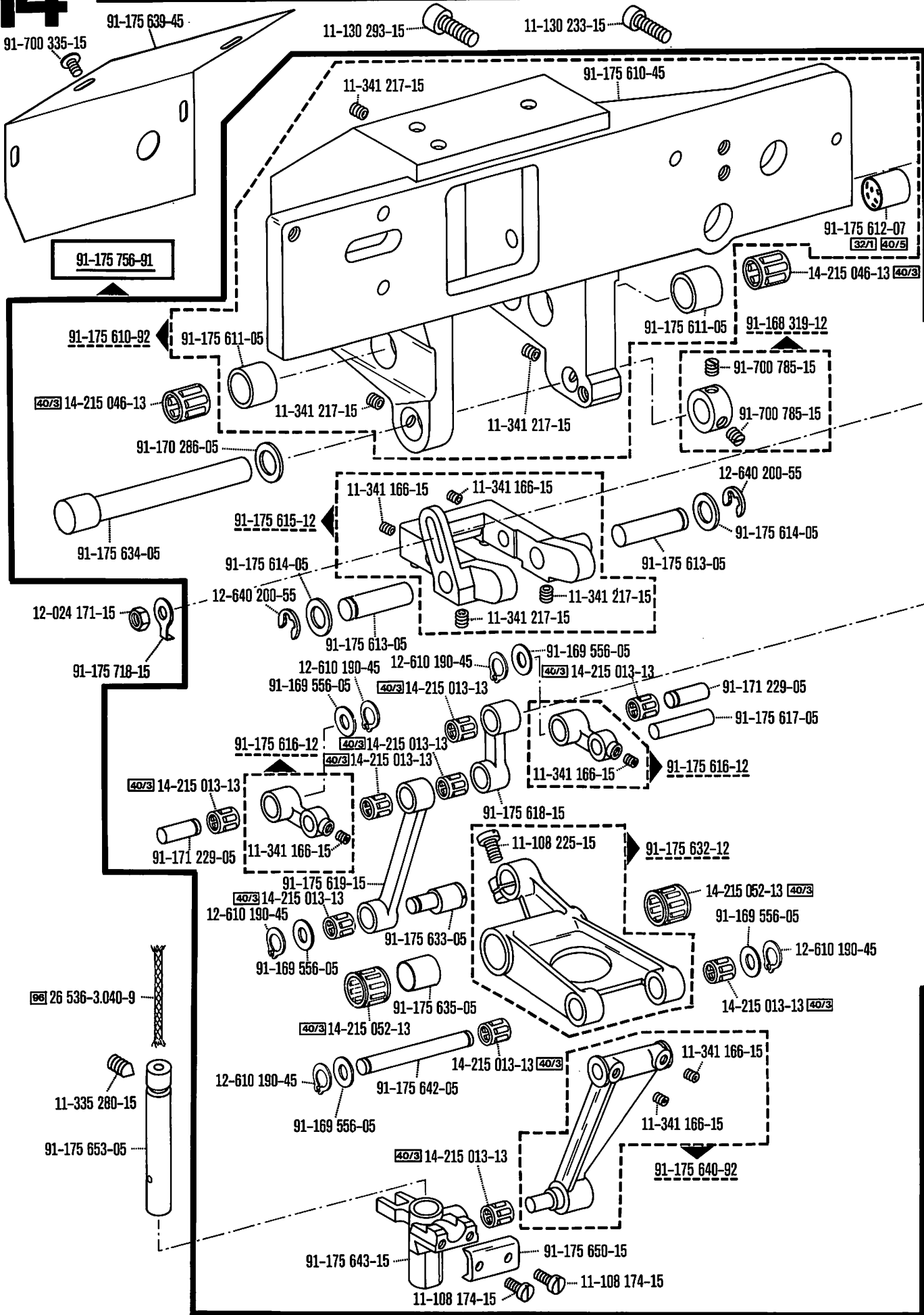

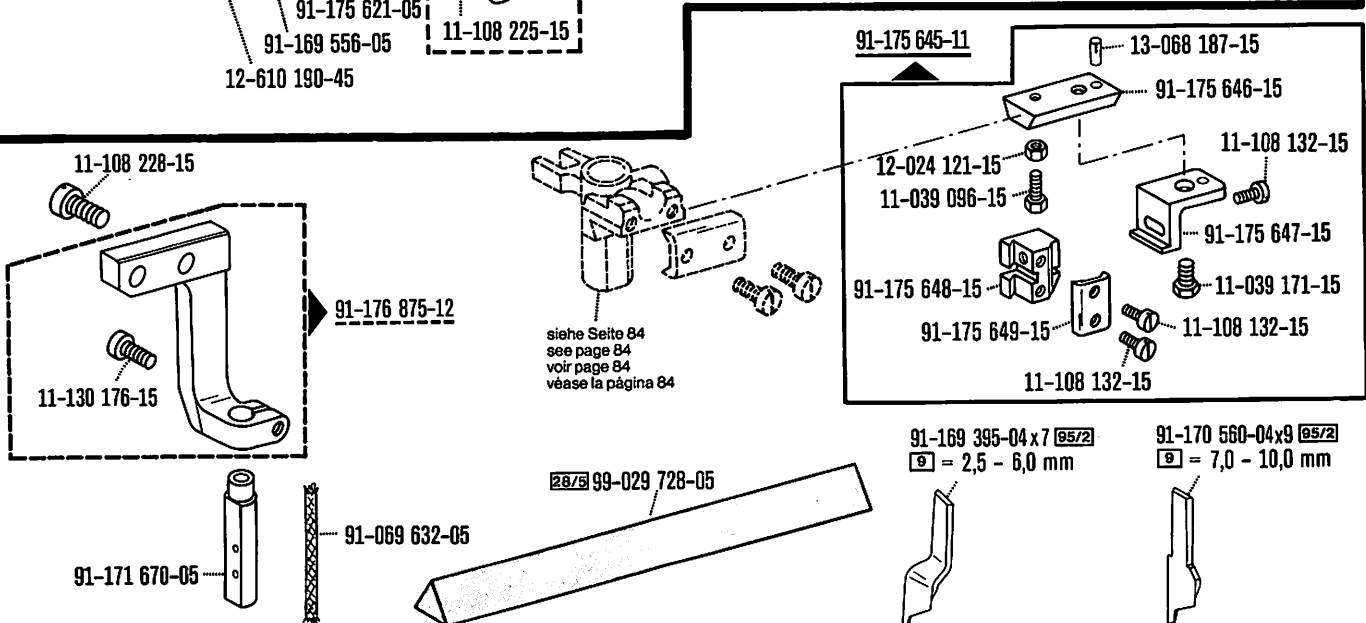
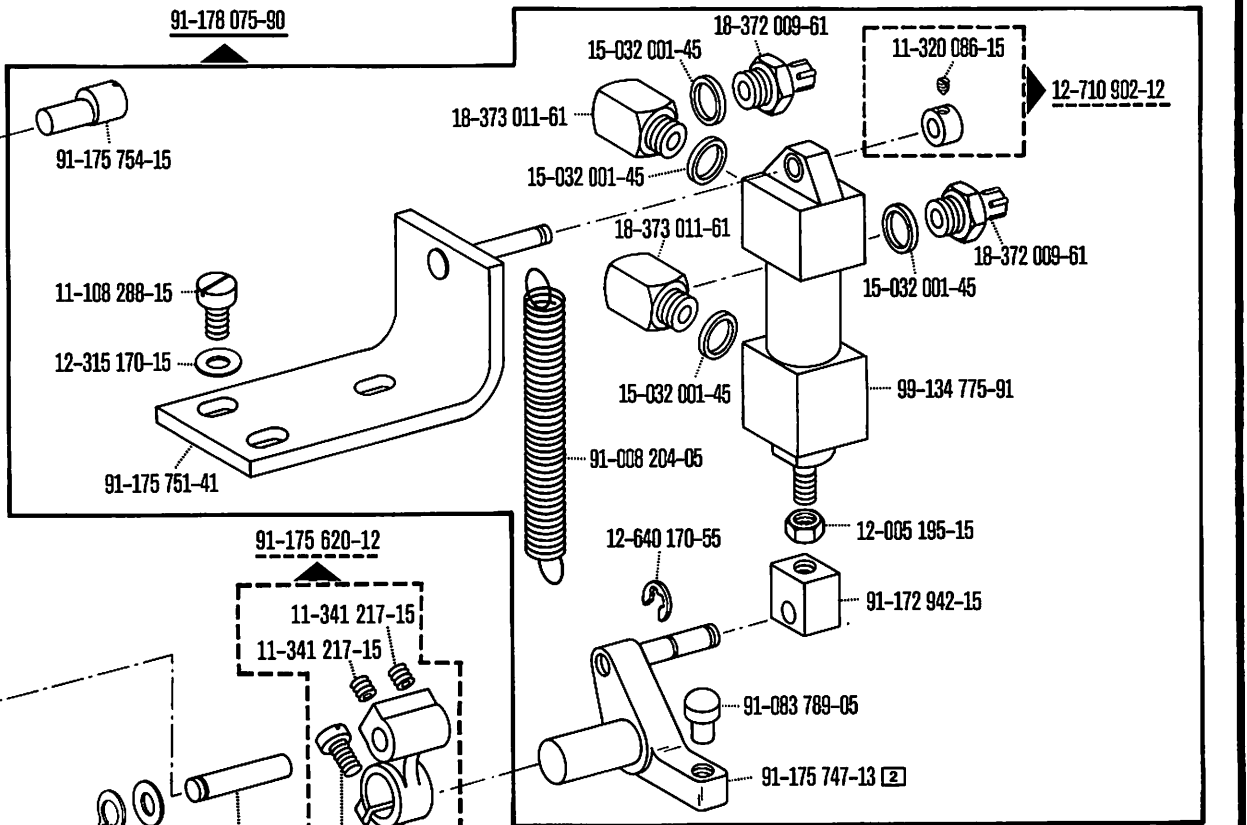
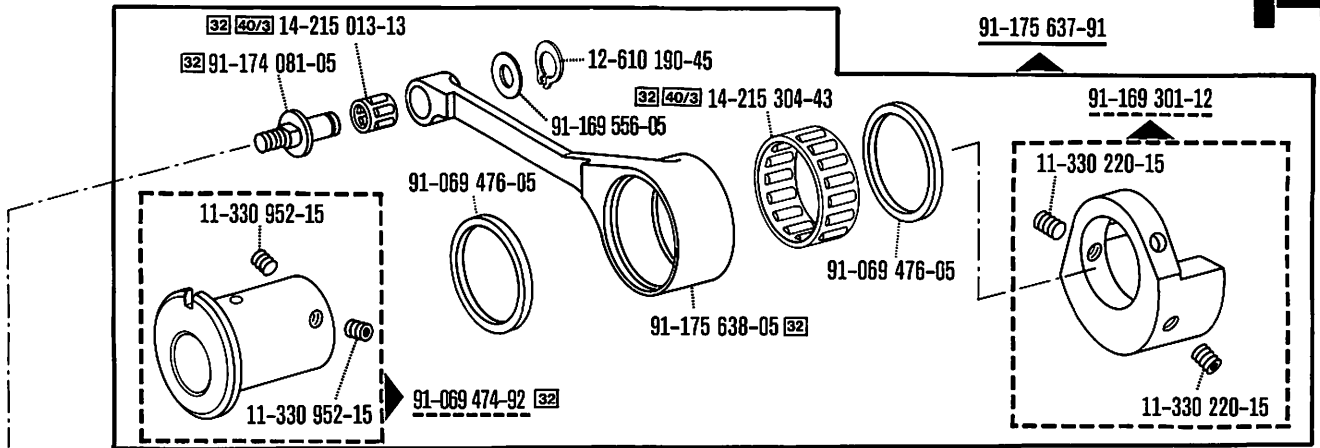

91-084 180-91

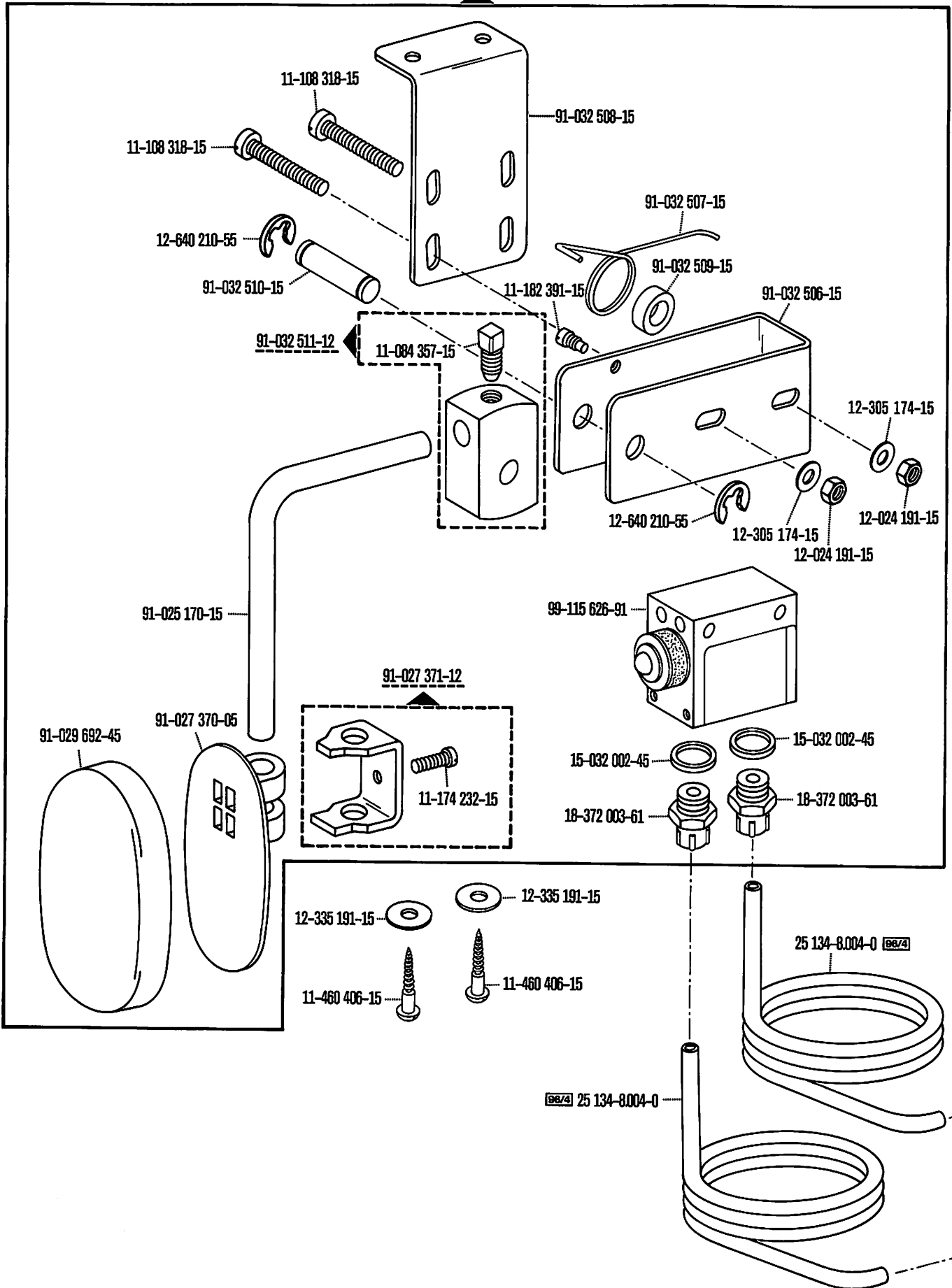

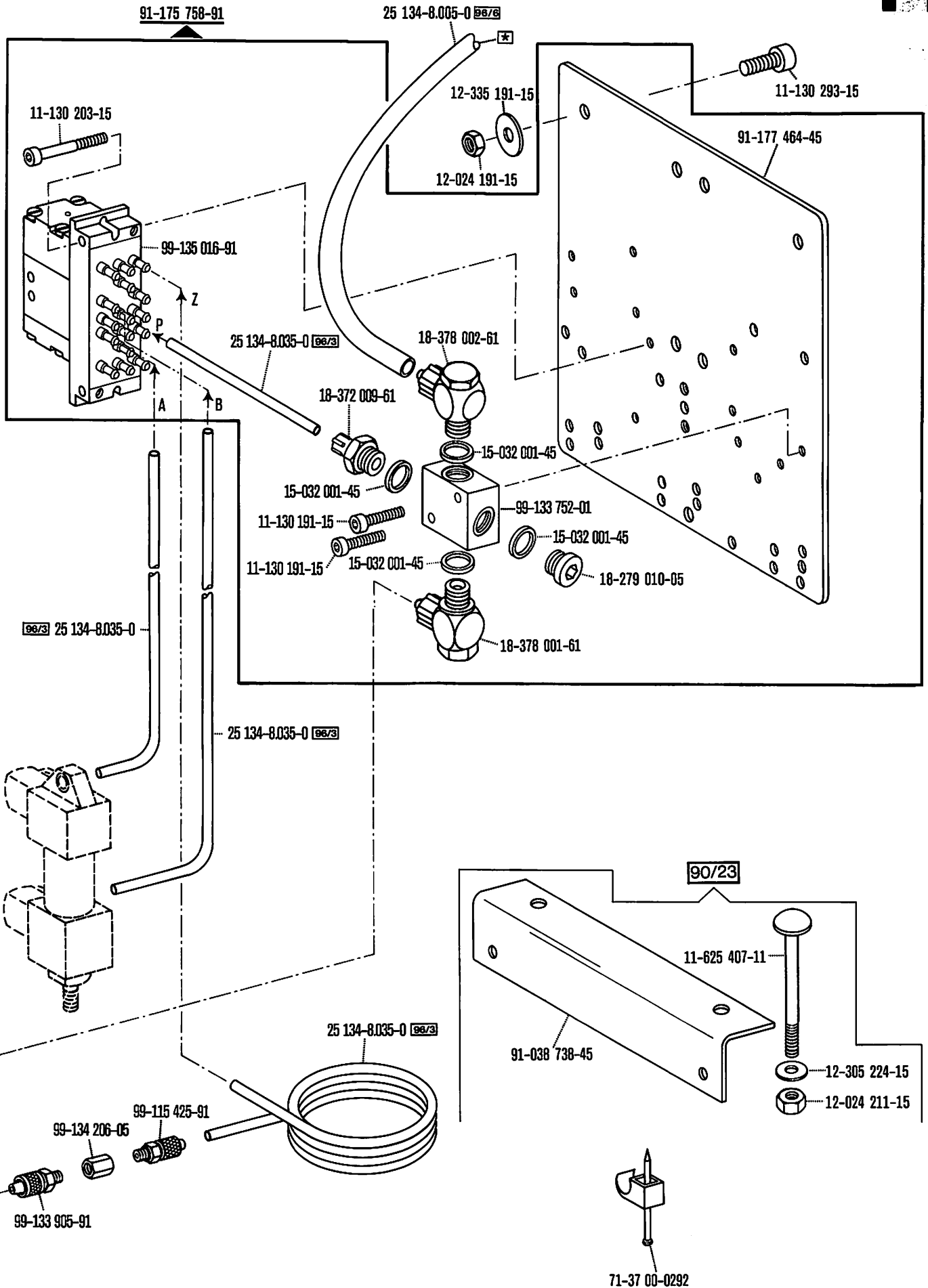

91-172 765-91 

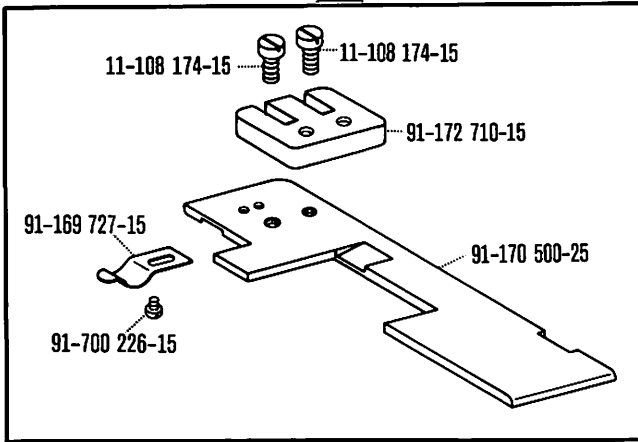

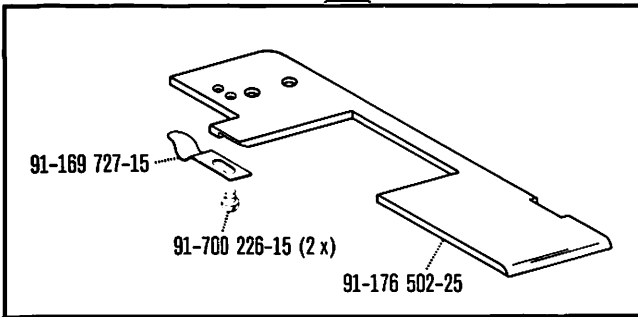

91-176 536-91 



91-170 274-92

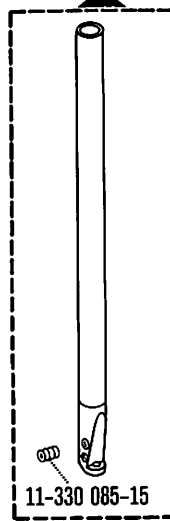

Einnadel · Single-needle
 Une aiguille · Aguja única

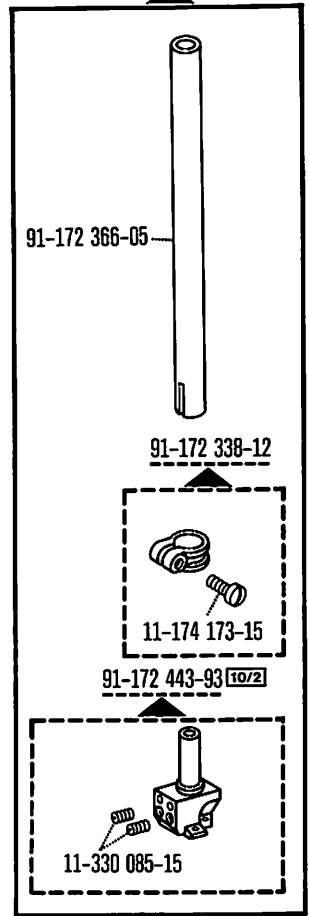

91-172 442-93 

10 = 4,0 mm
 Zweinadel · Two-needle
 Deux aiguilles · Dos agujas



System 4463-35 
 Système 4463-35 
 Sistema 4463-35 

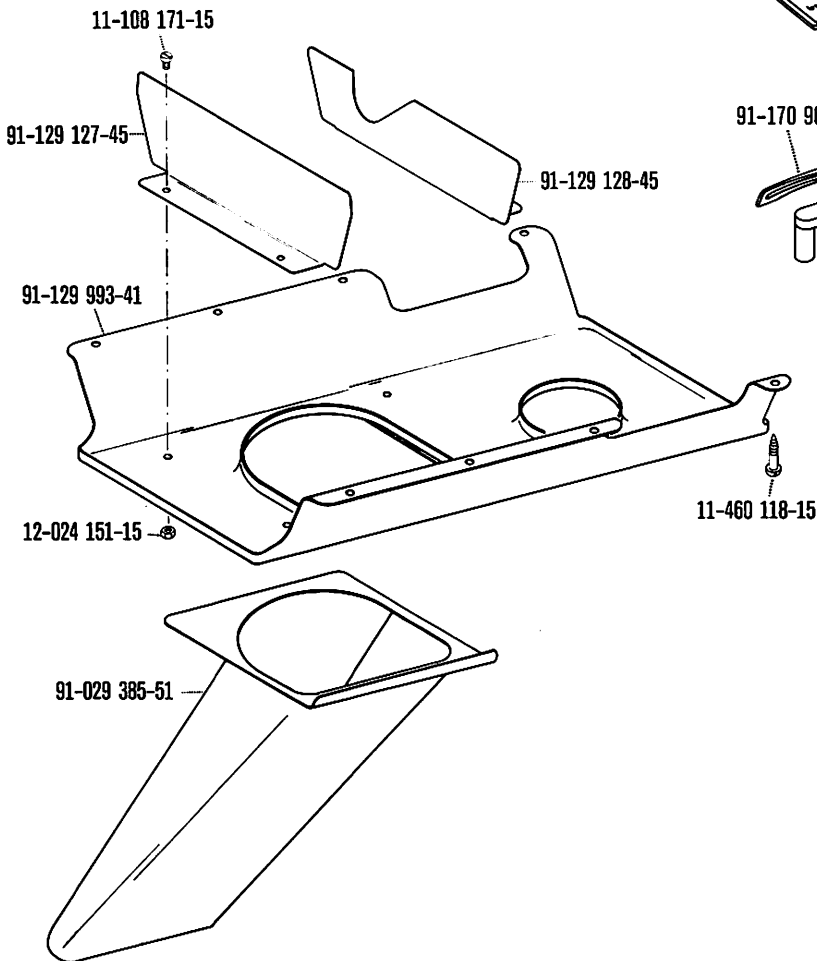

91-170 966-05 (-703/01)



91-172 136-00

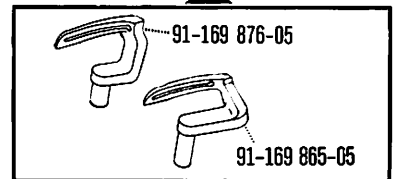

91-170 208-45 (-733/01)
91-170 201-45 (-733/11; -733/12)

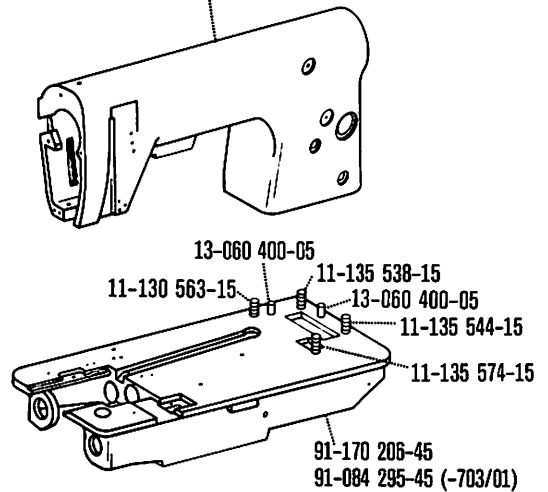

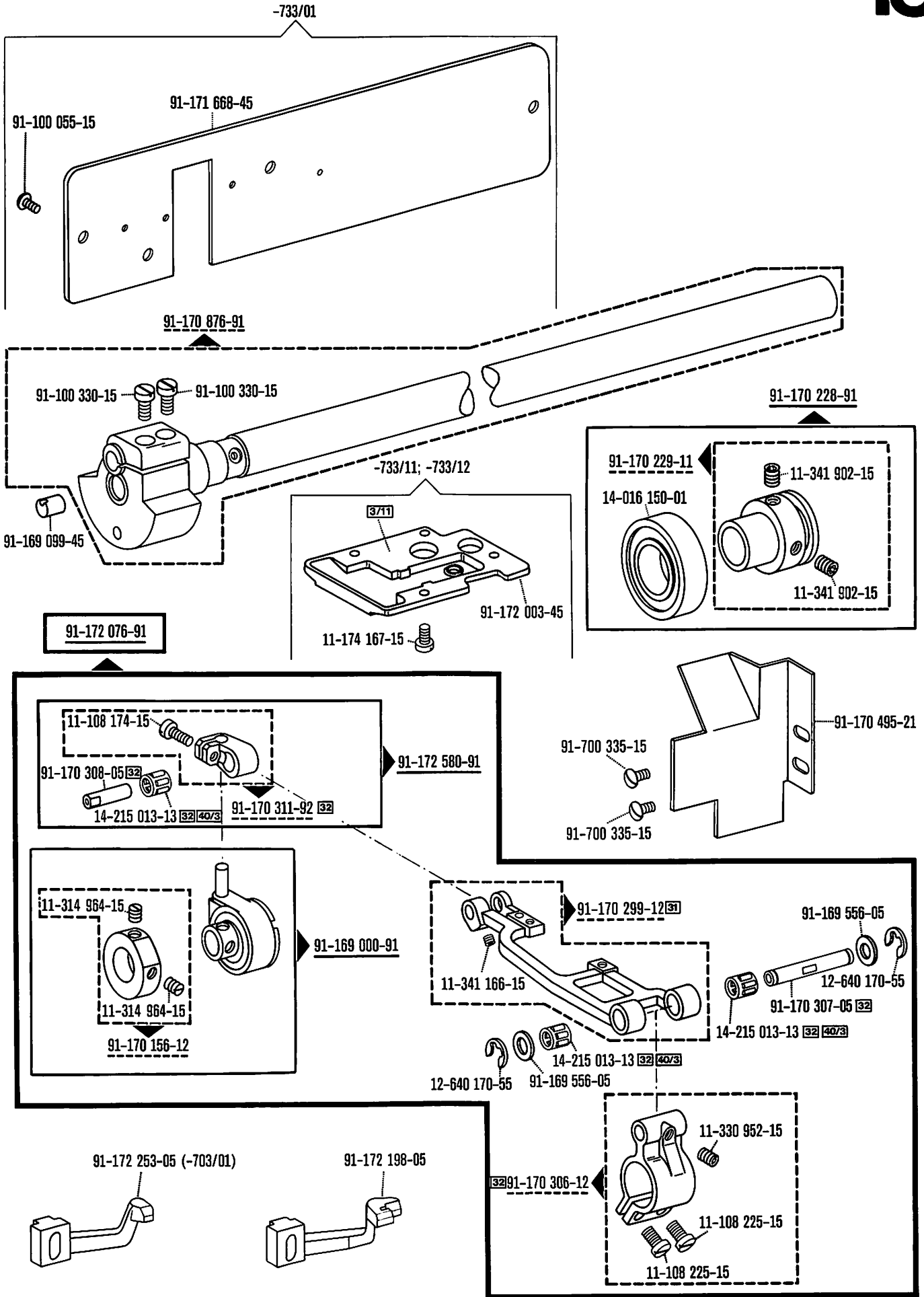

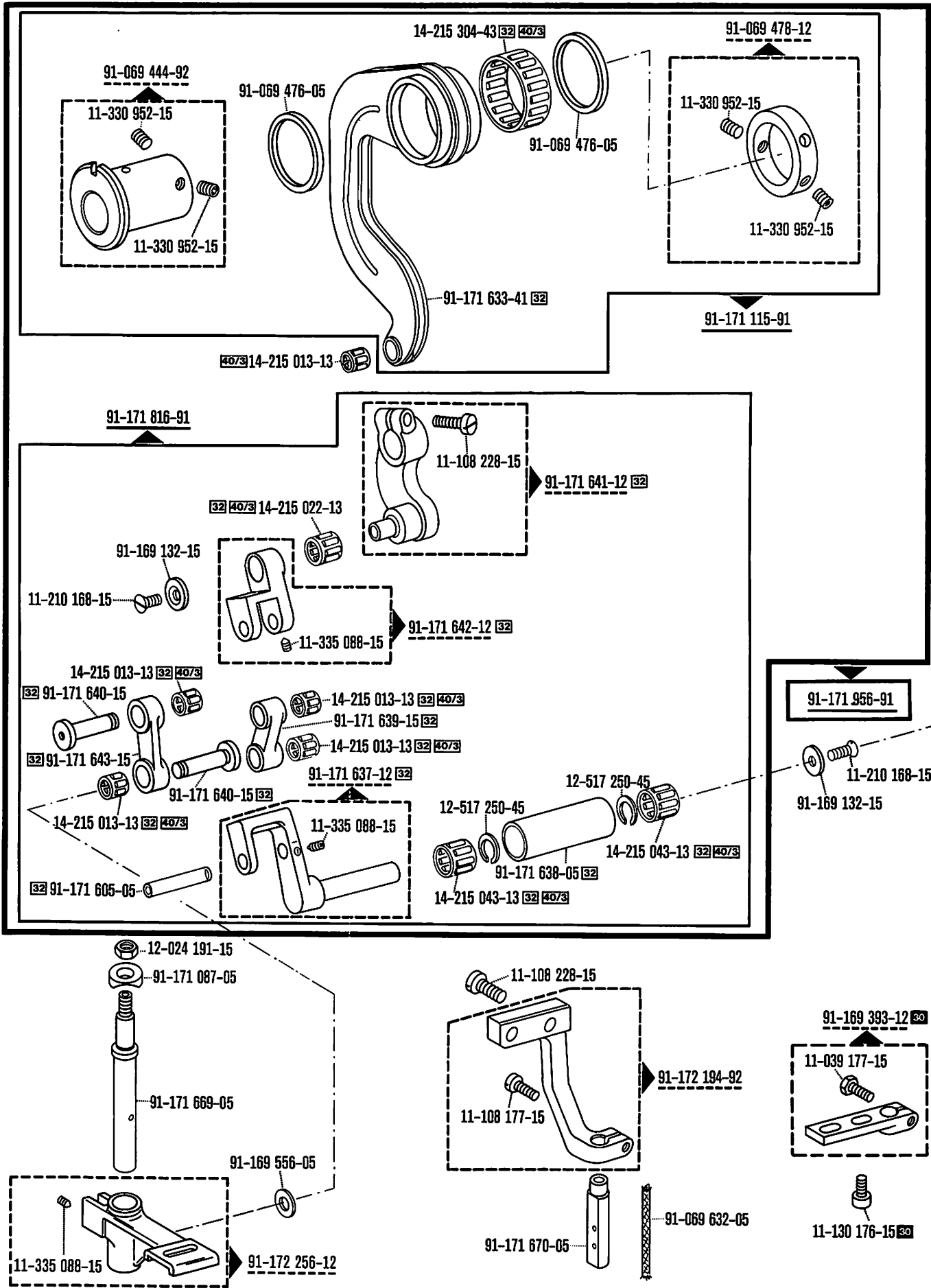

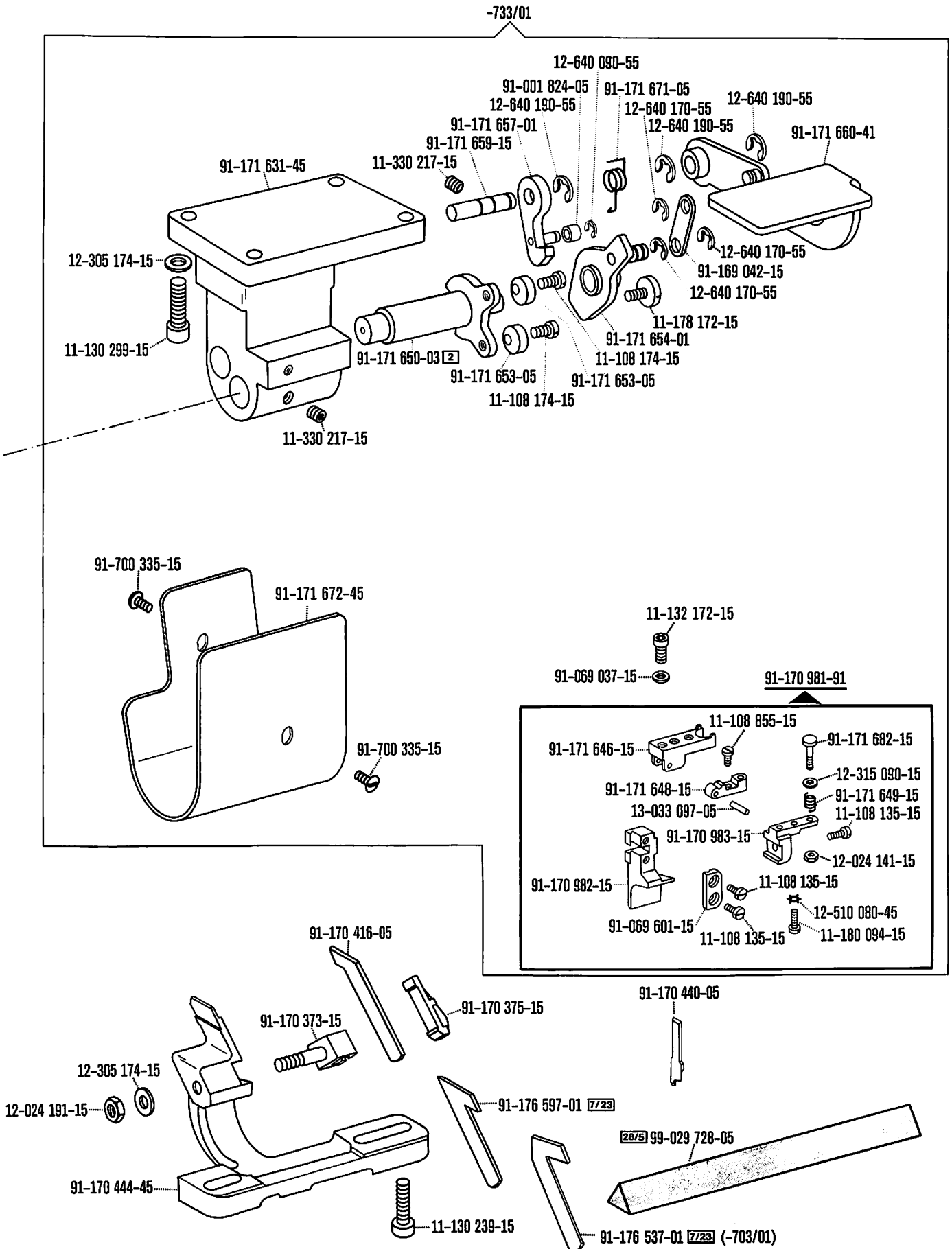

15

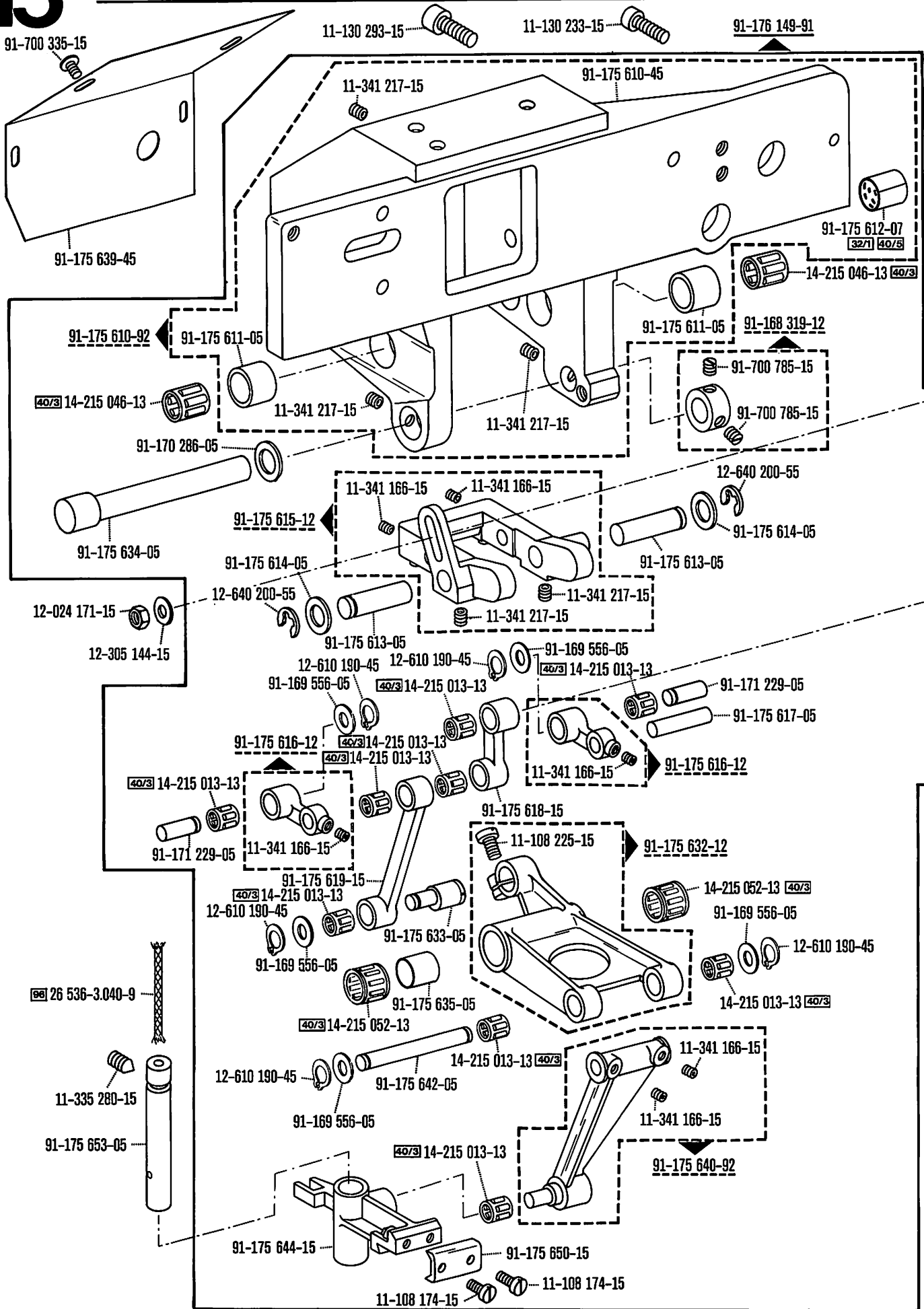

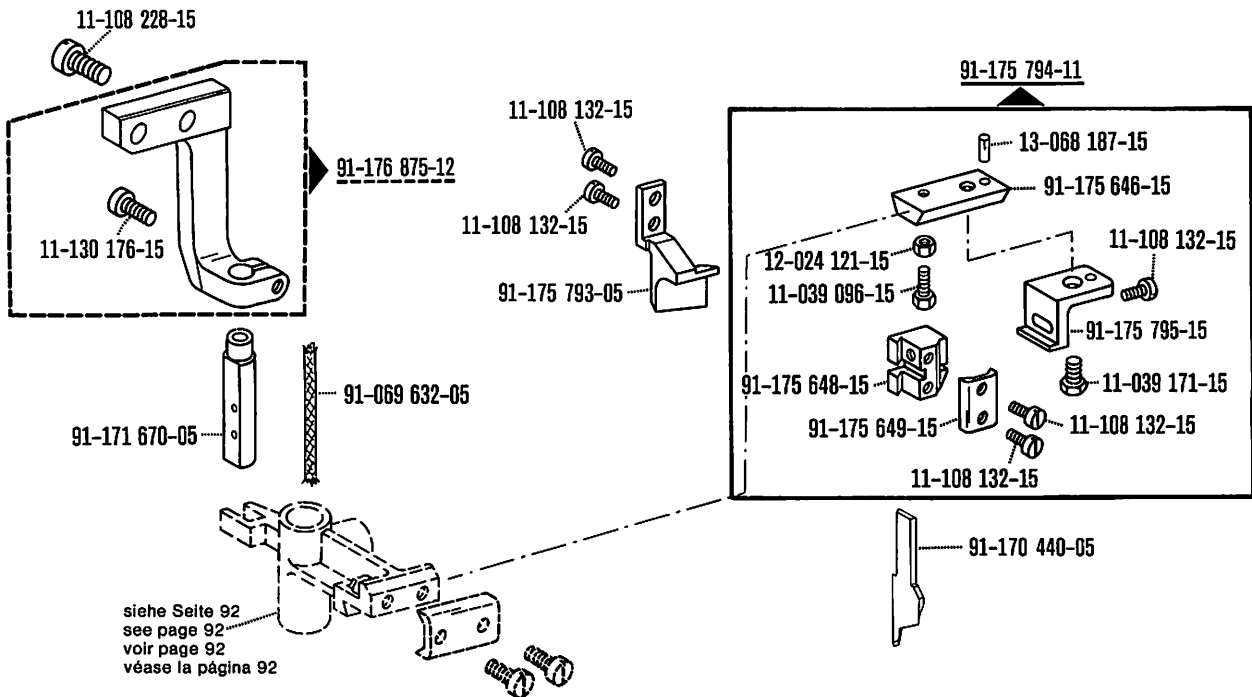
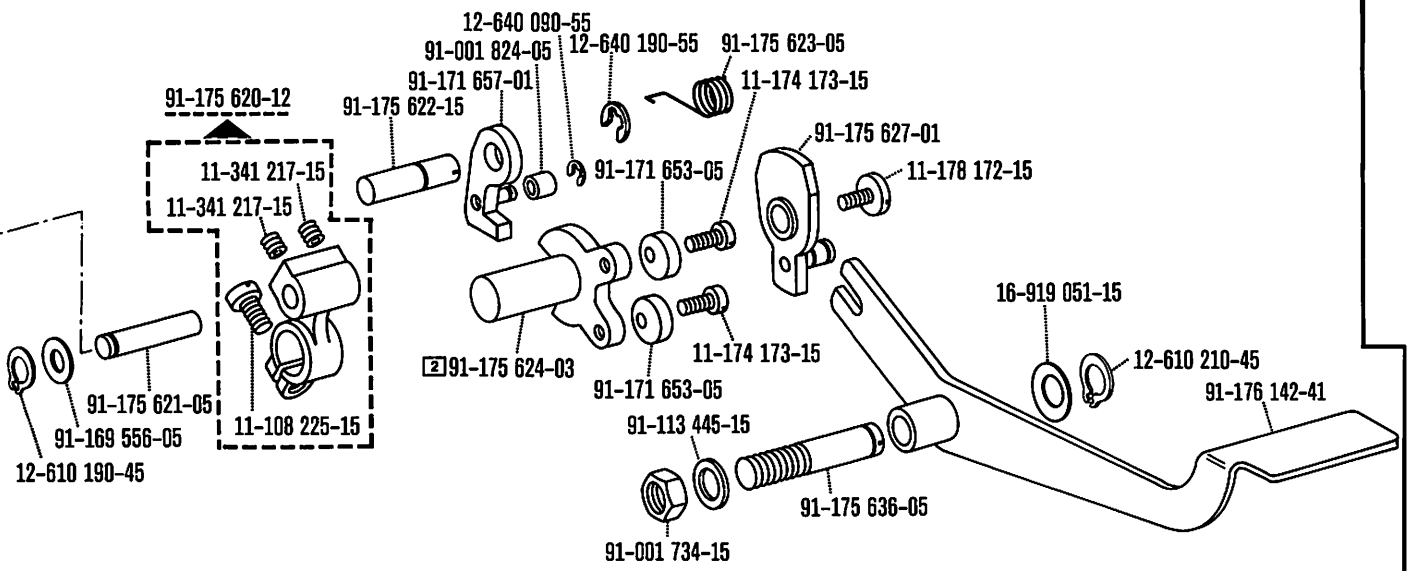
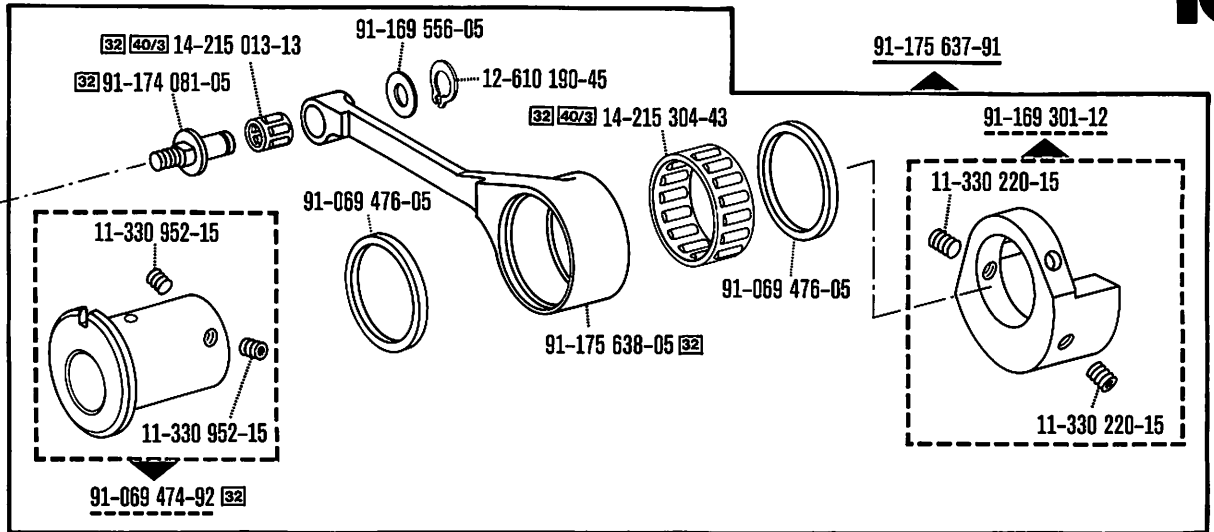

siehe Seite 92
see page 92
voir page 92
véase la página 92

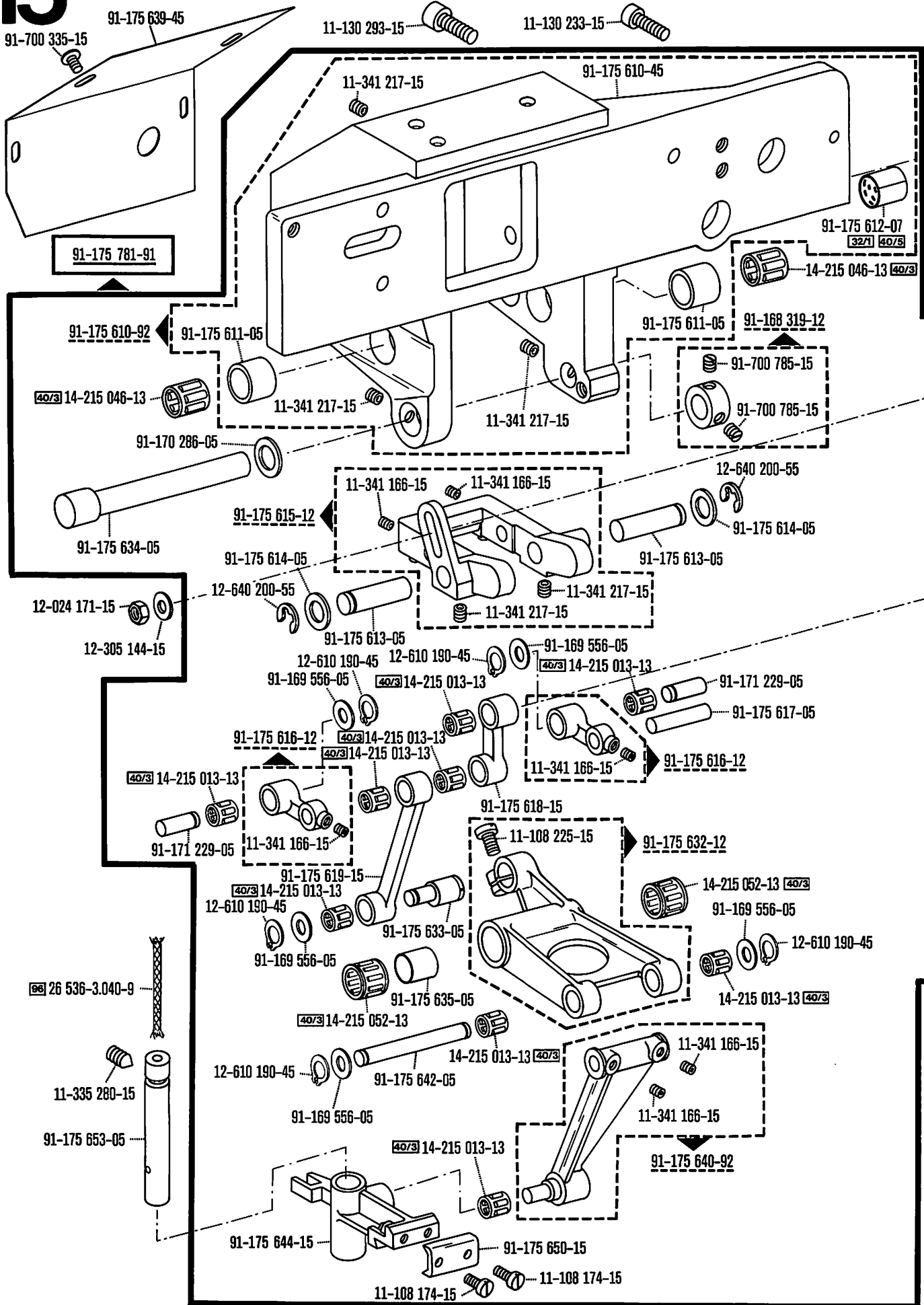

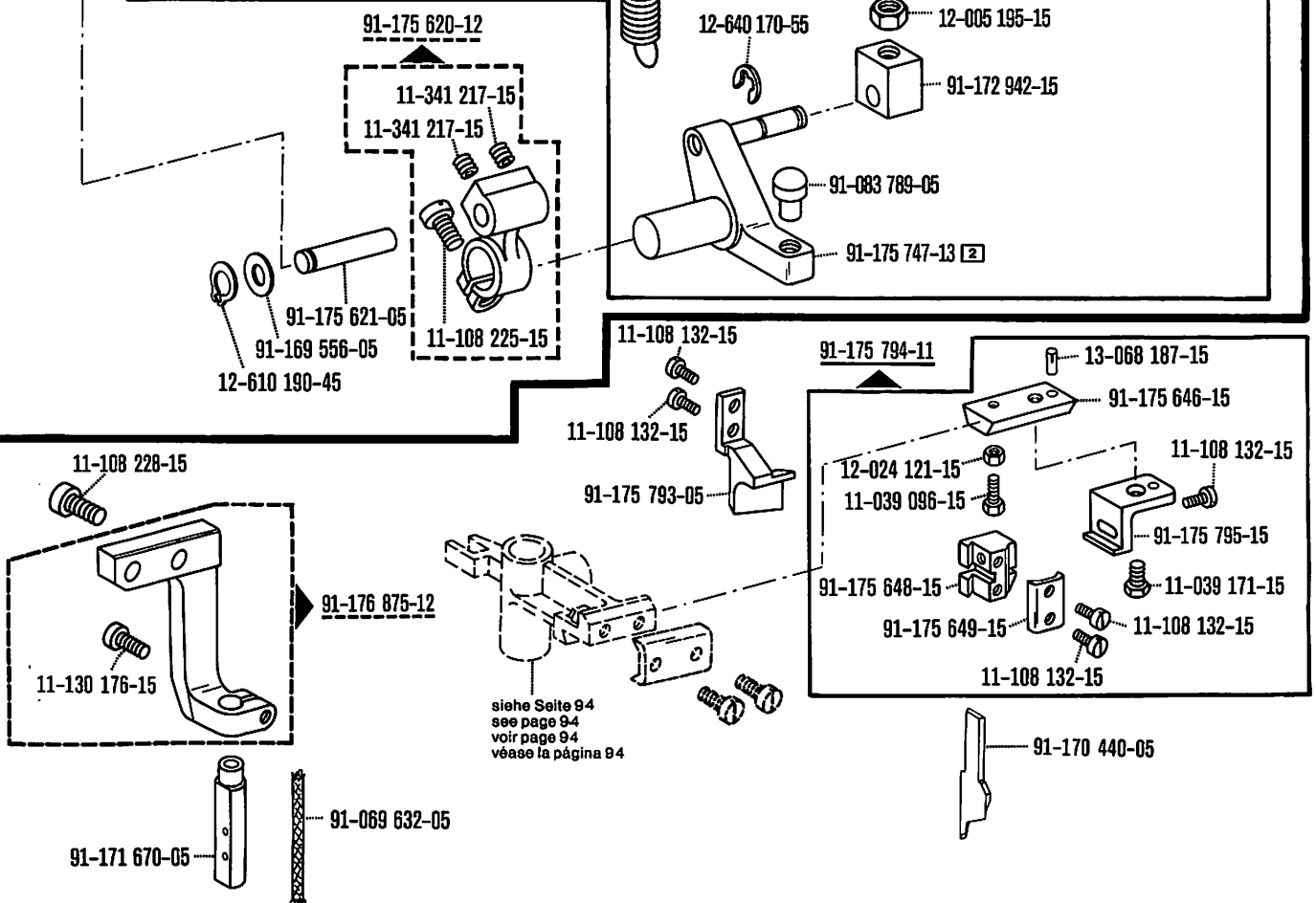
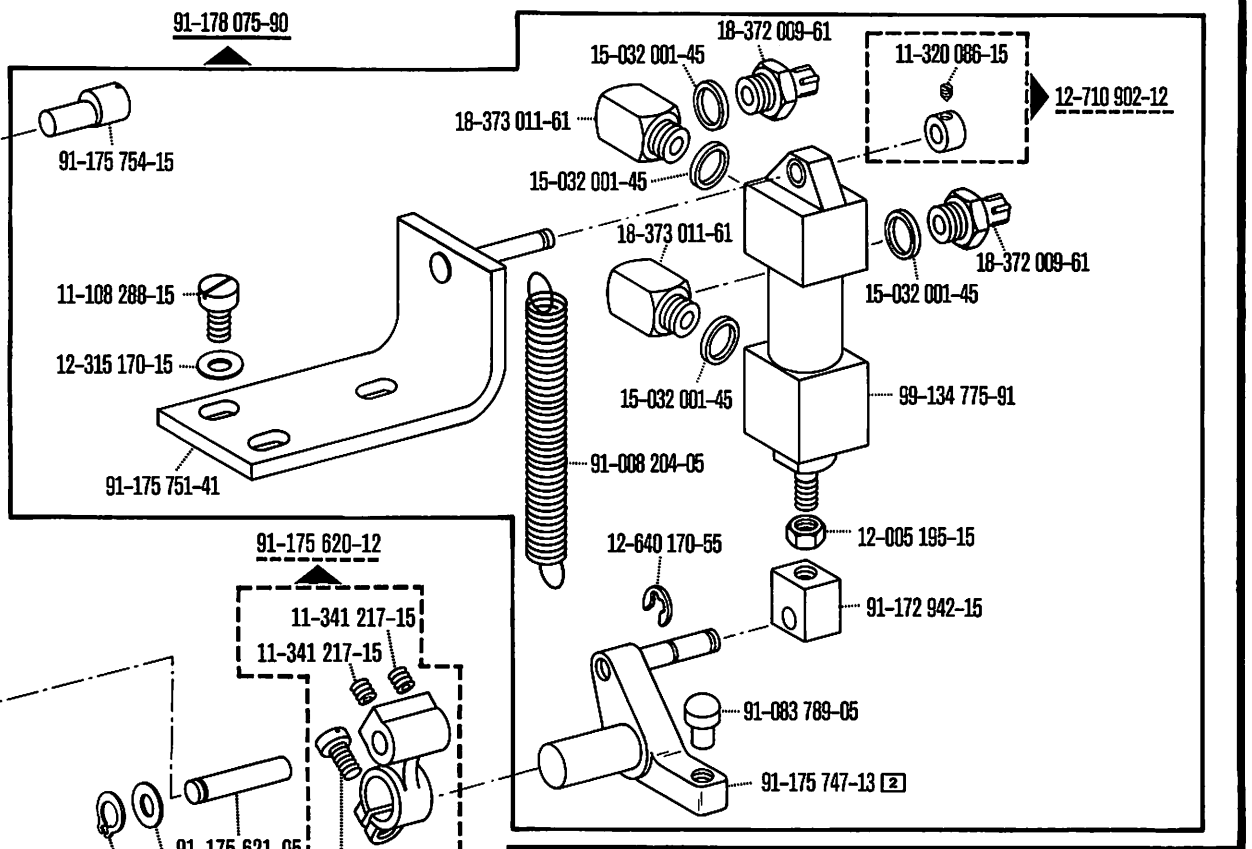
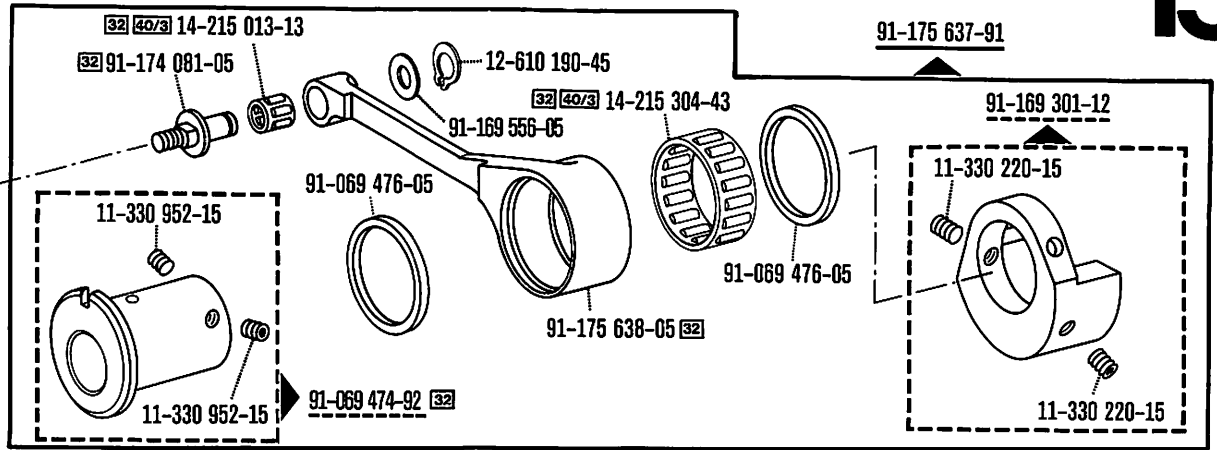

91-084 180-91

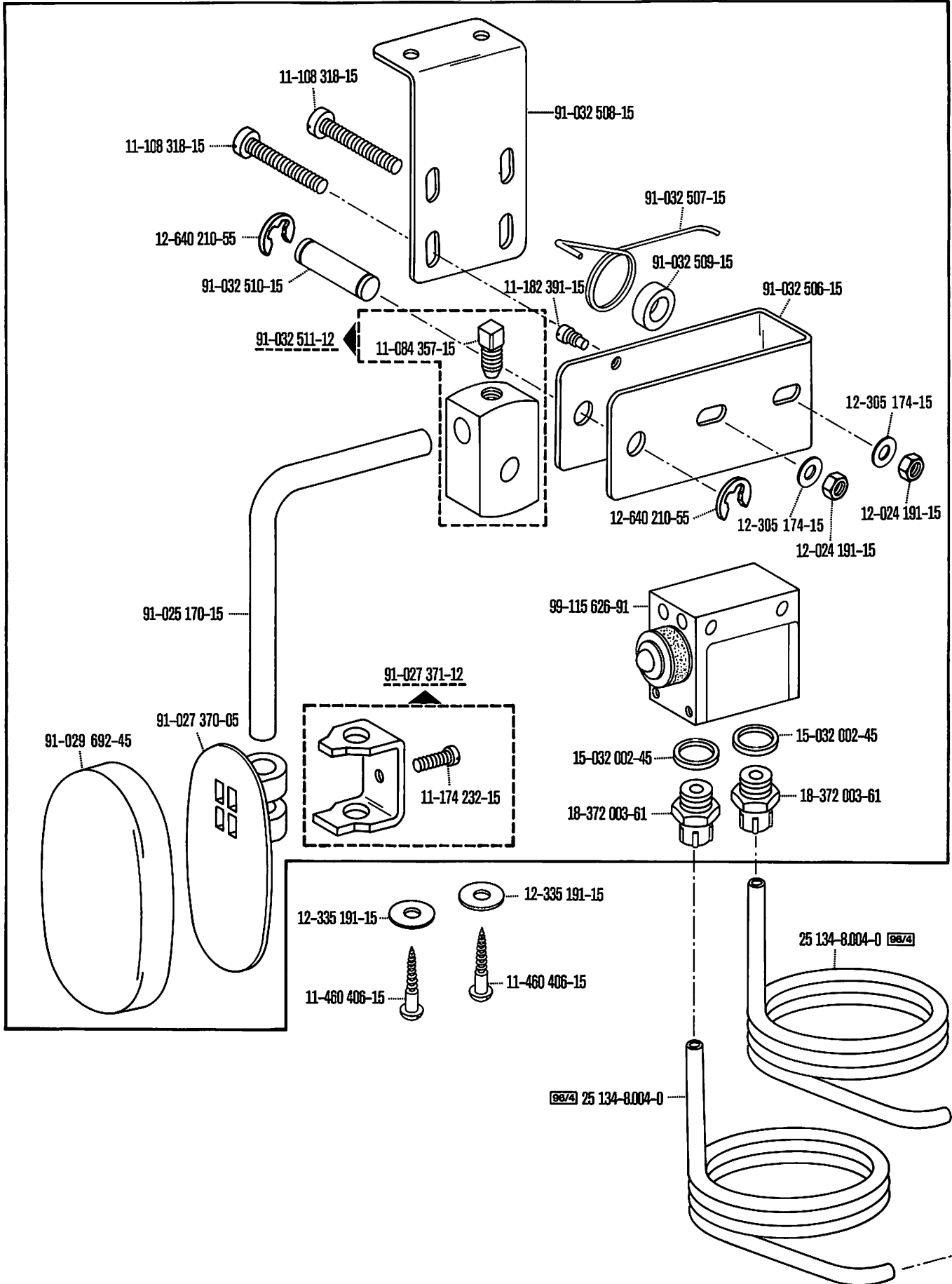

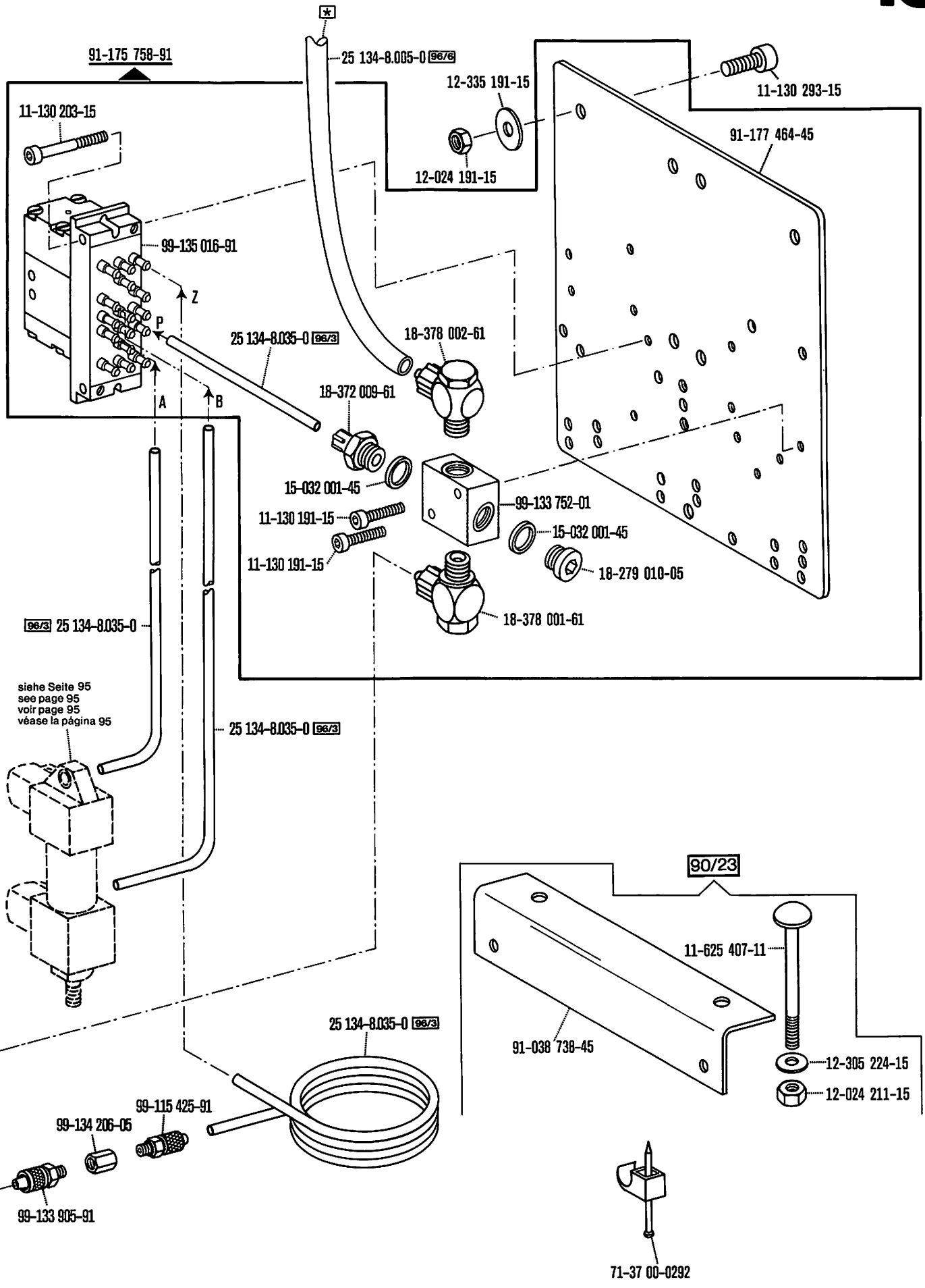

00-000 000-00 00-000 000-00 00-000 000-00

☐ siehe Erläuterungen Register O
see explanations on section O
voir légende registre O
ver explicaciones del registro O

★ Zur Wartungseinheit
For conditioning unit
Pour la conditionneur d'air comprimé
Para las require grupo acondicionador del aire

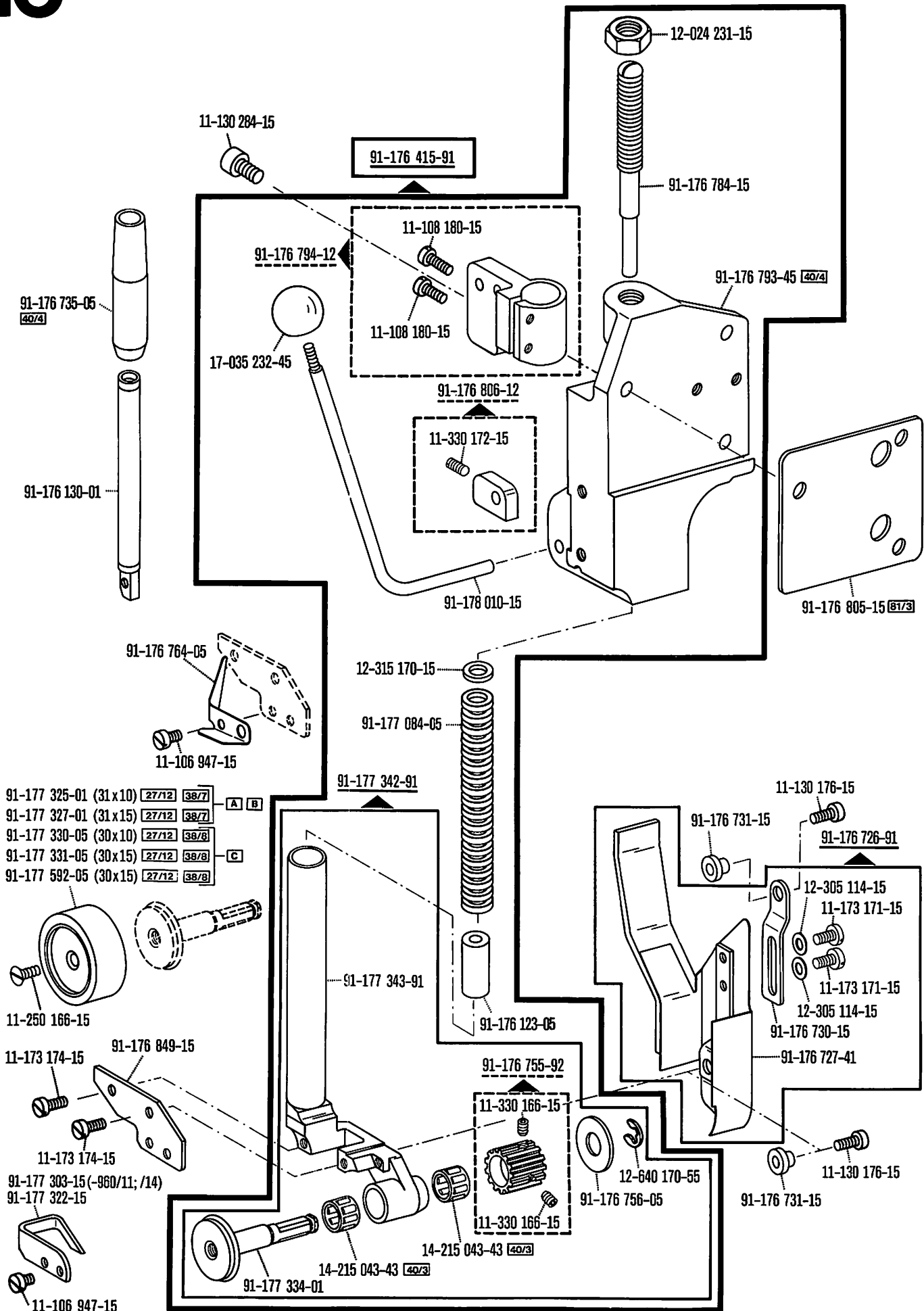

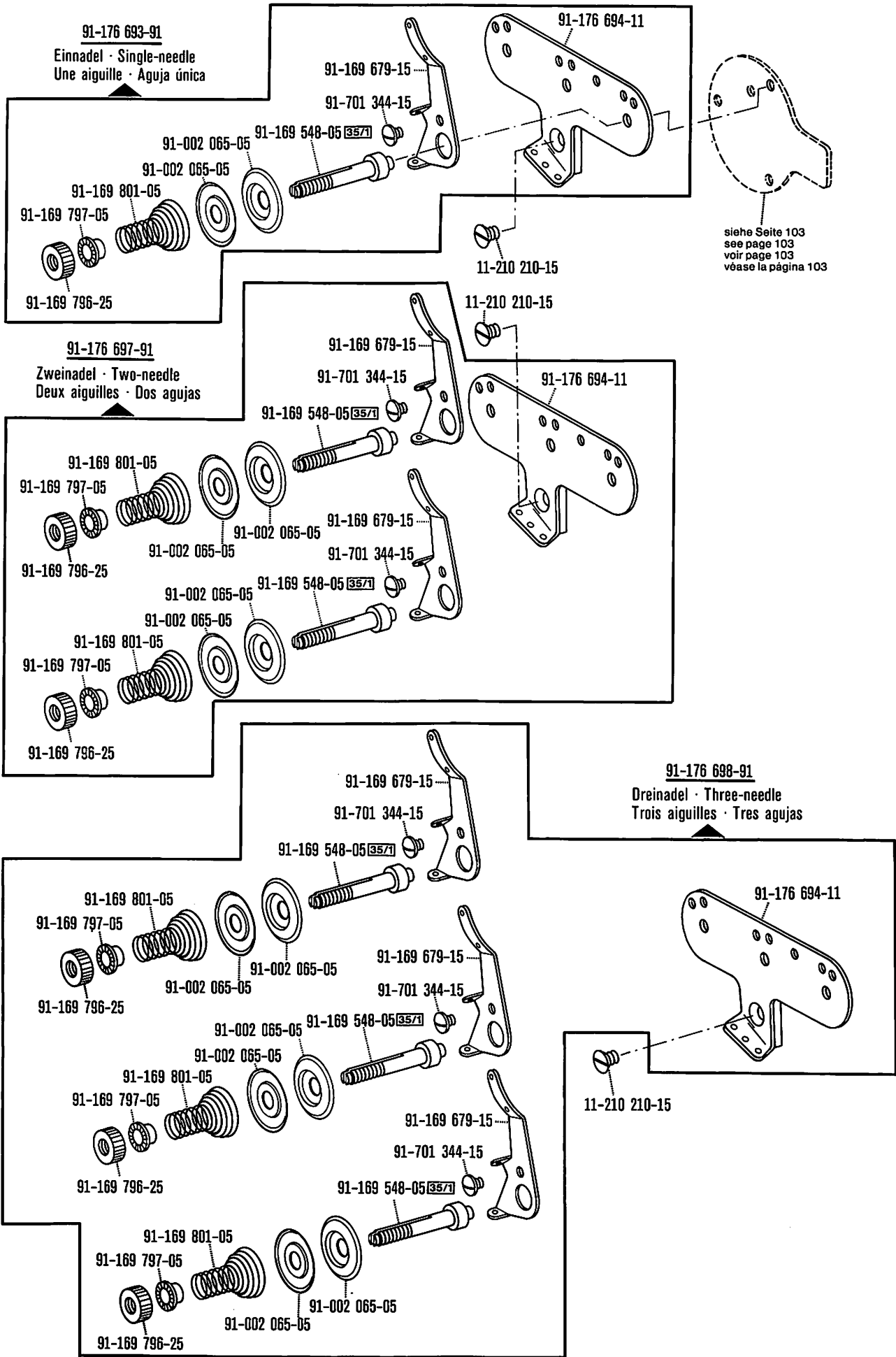

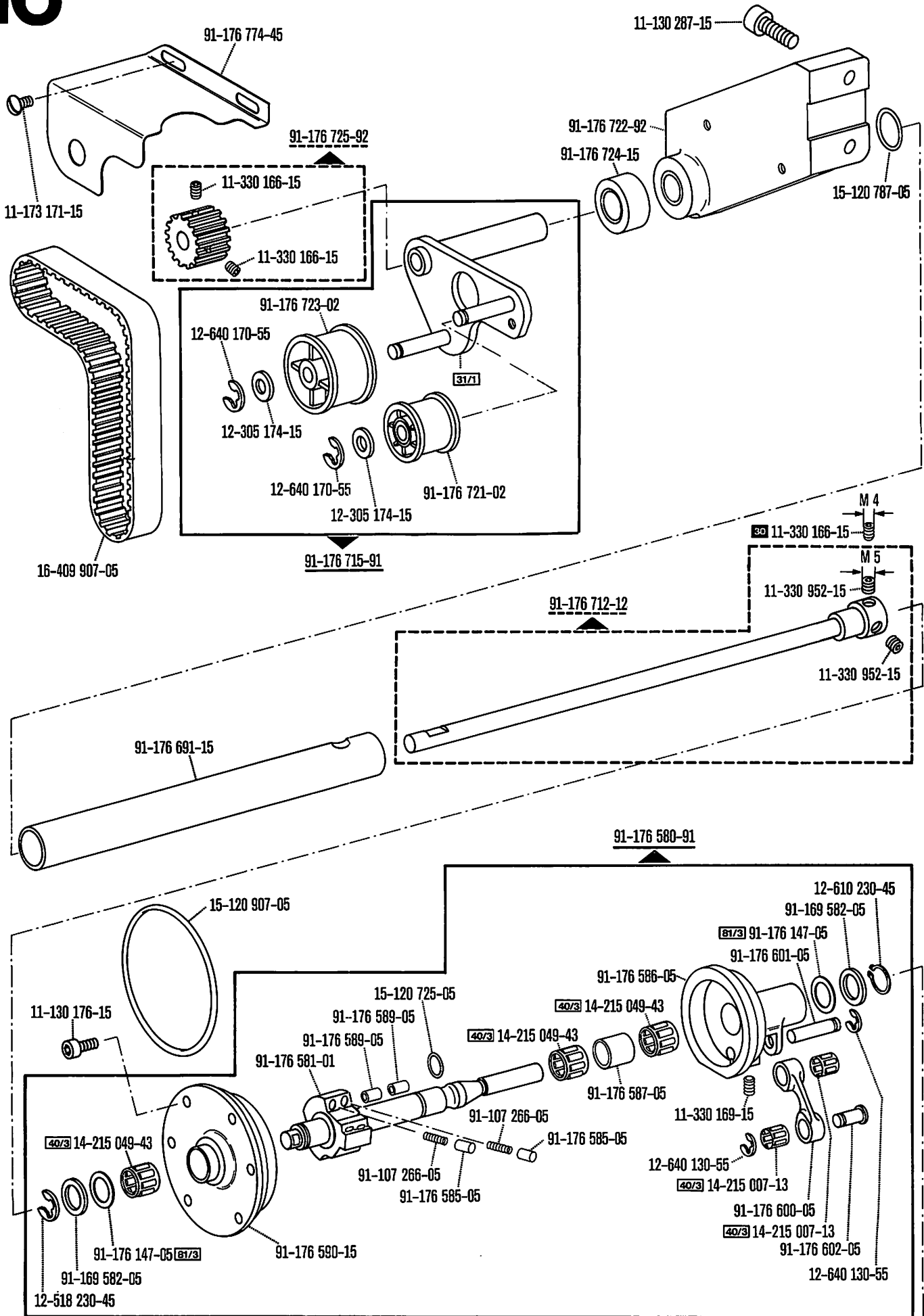

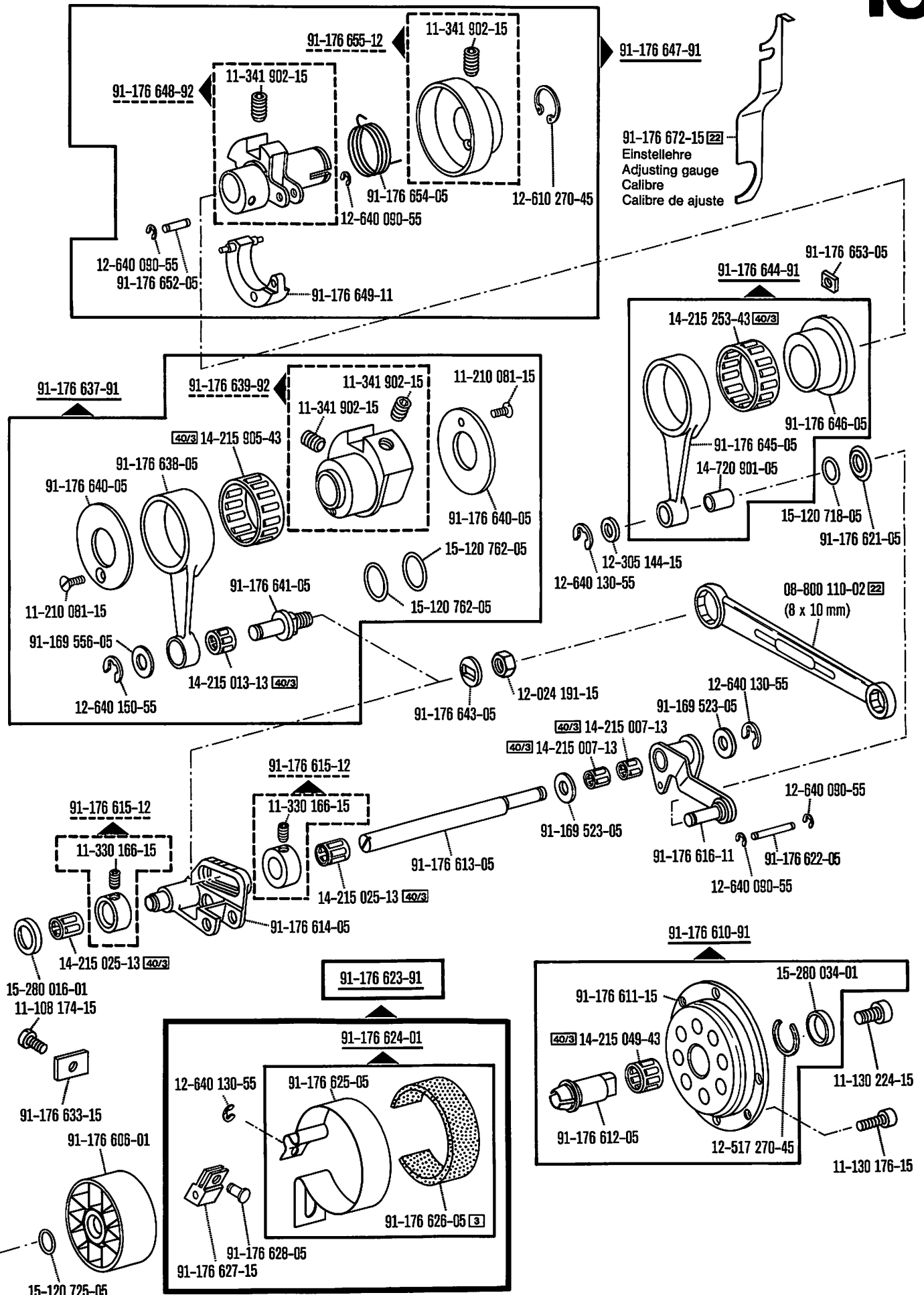

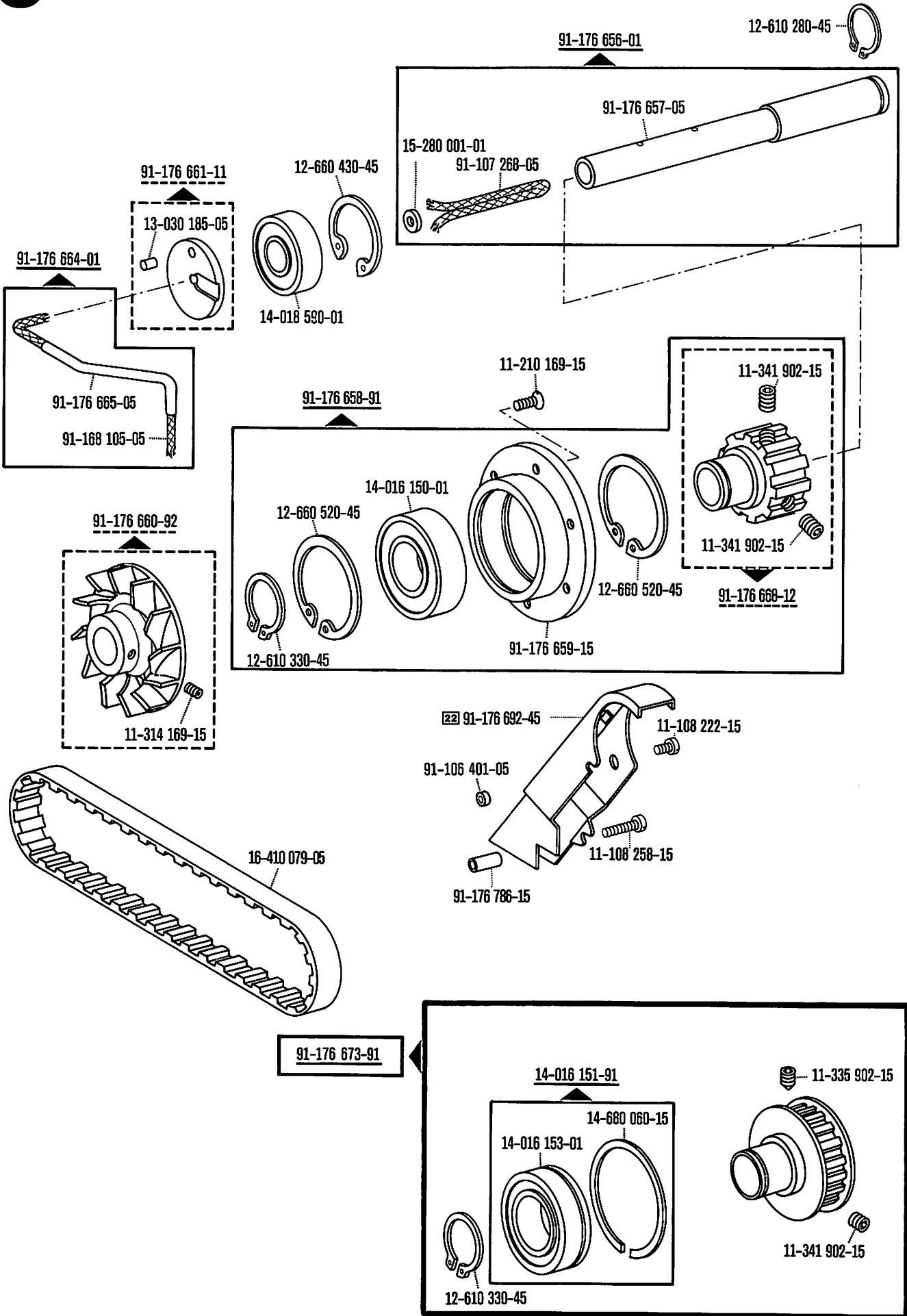

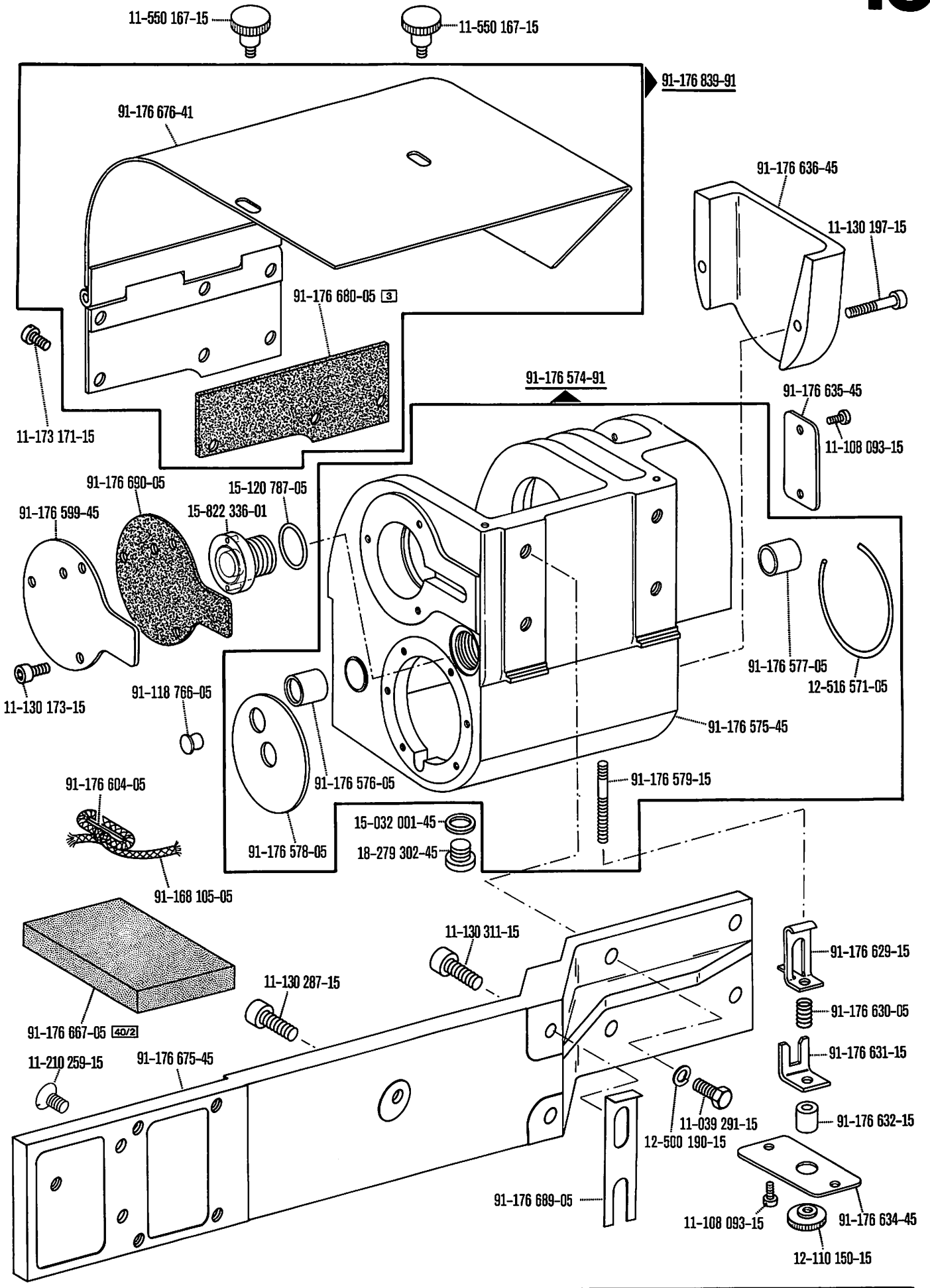

00-000 000-00 00-000 000-00 00-000 000-00 siehe Erläuterungen Register O
 see explanations on section O
 voir légende registre O
 ver explicaciones del registro O

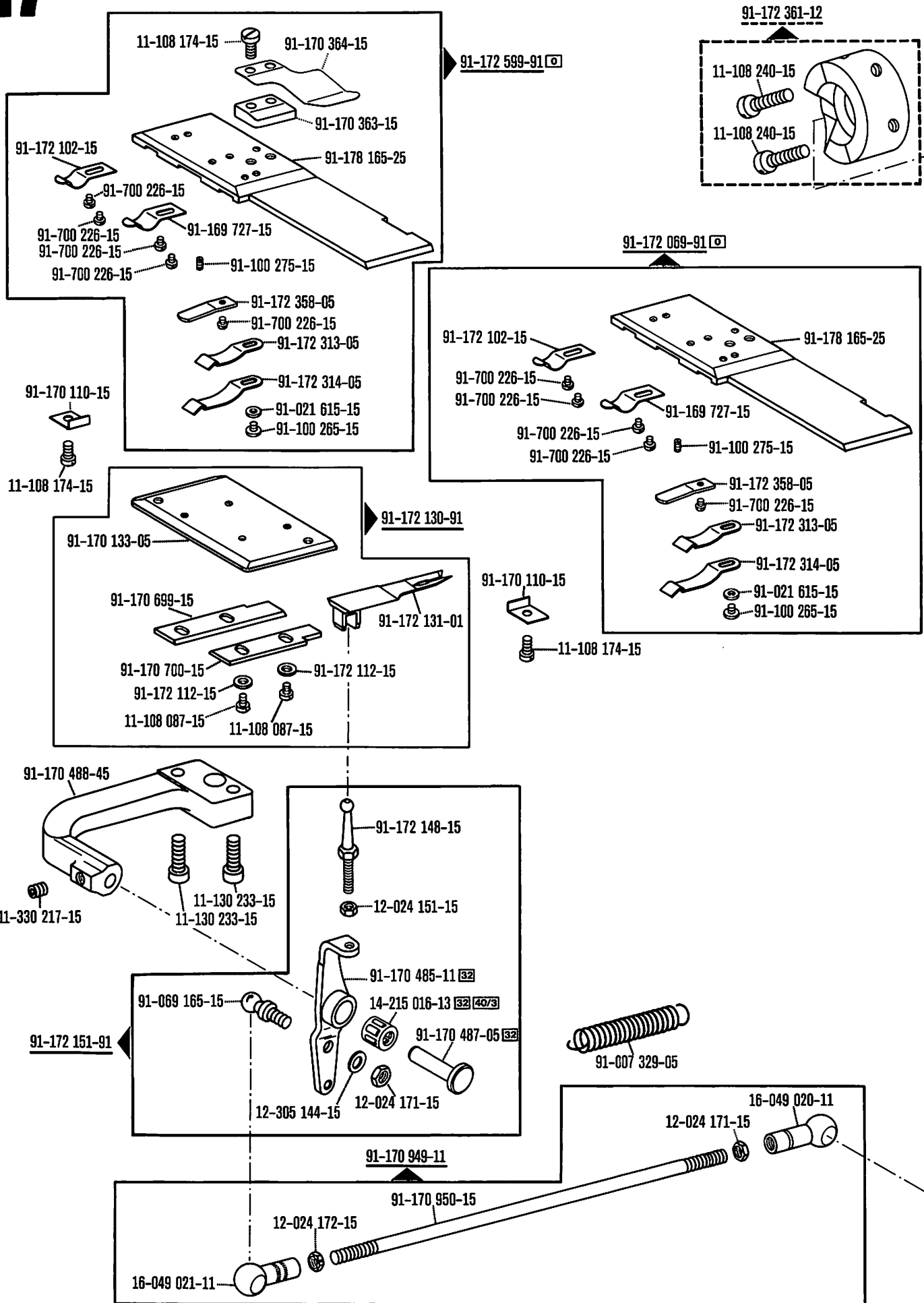

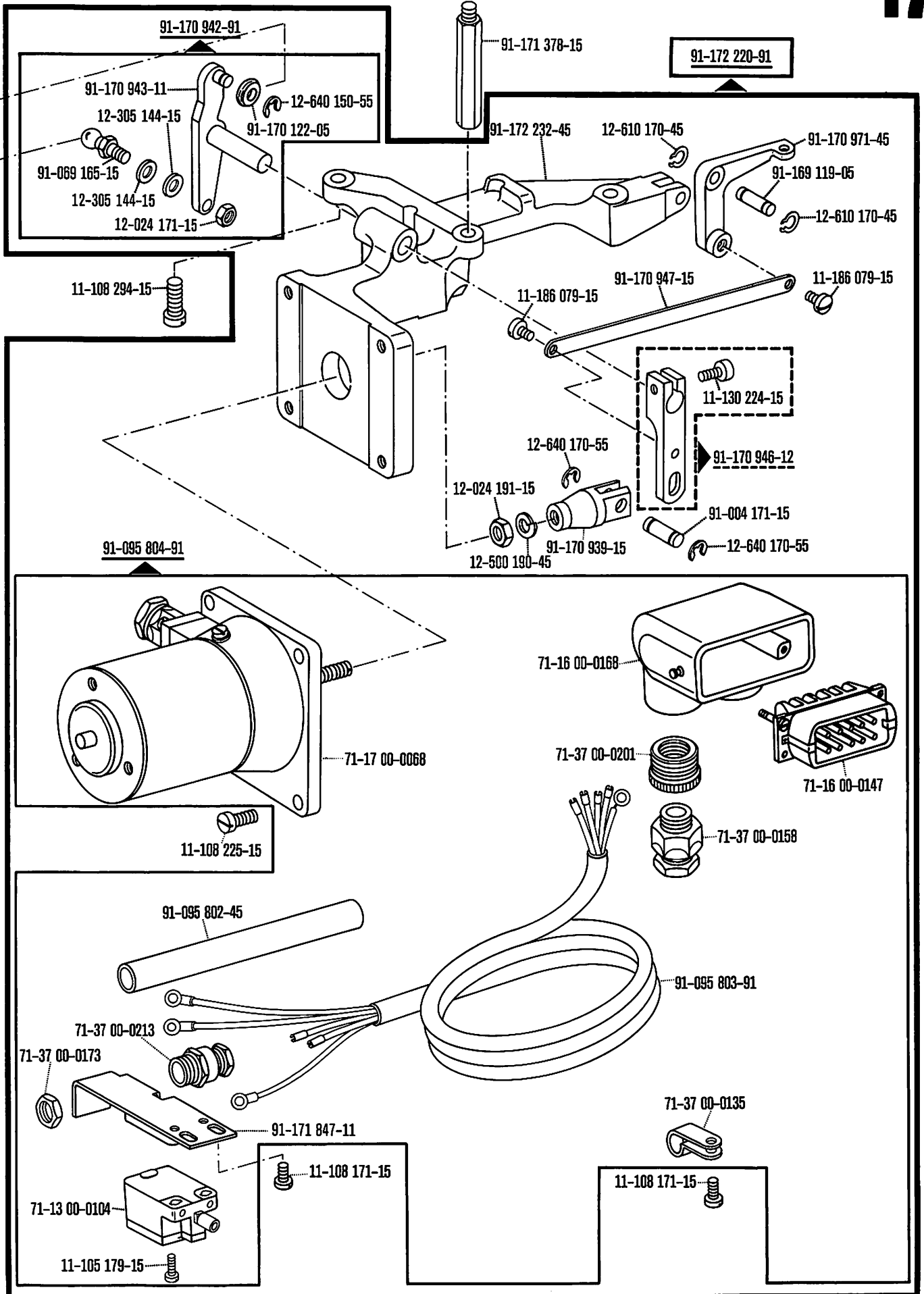

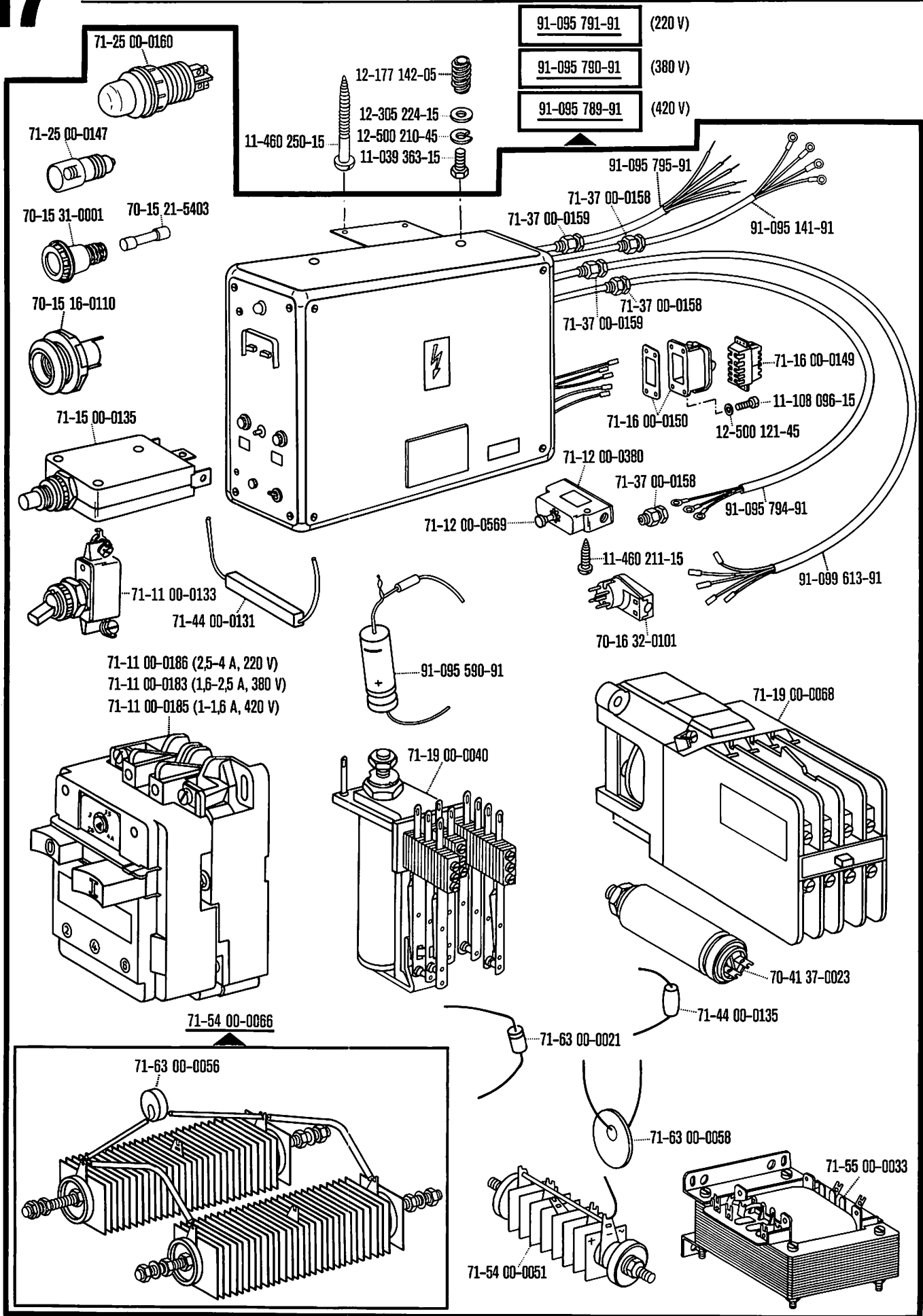

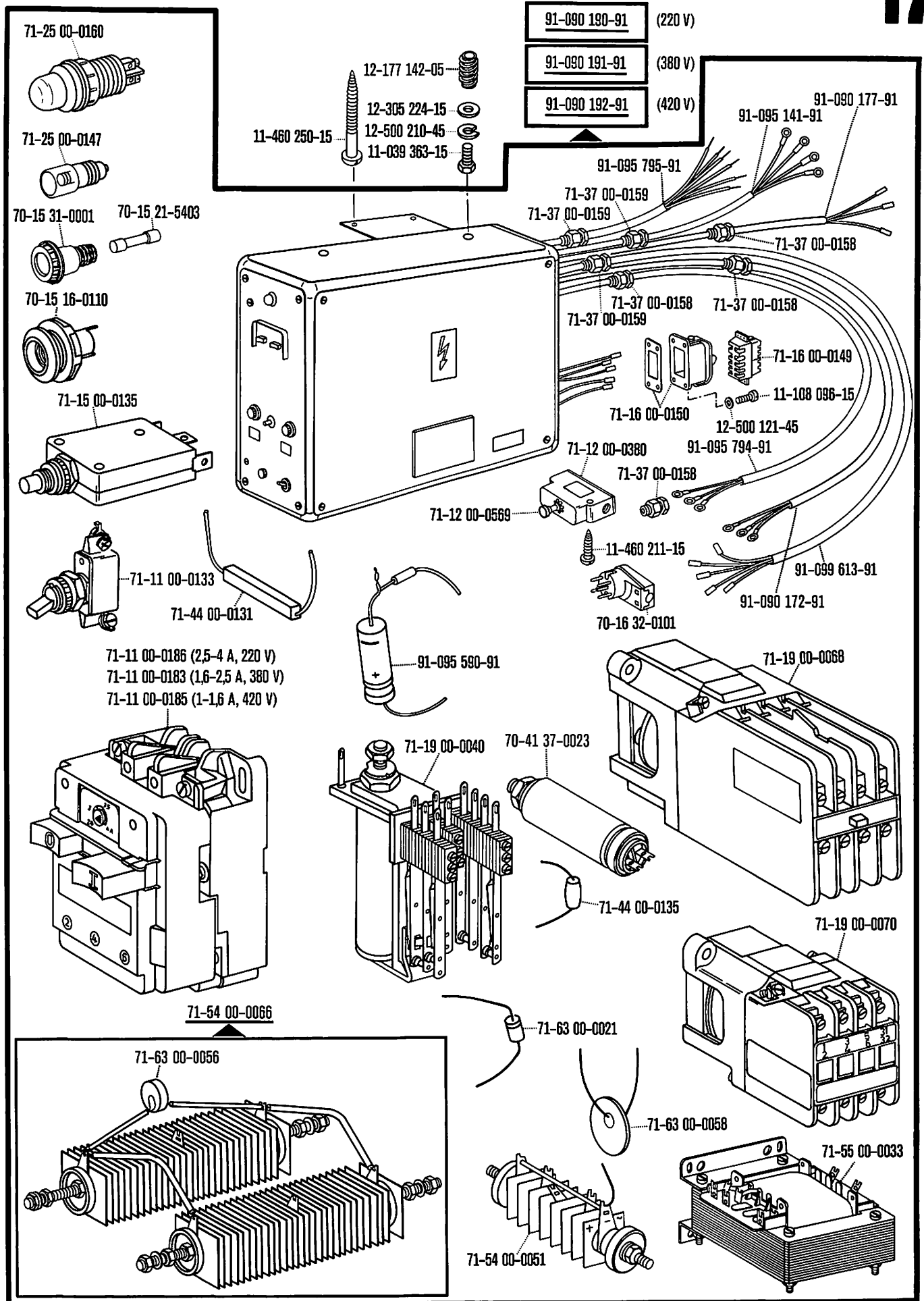

siehe Seite 22
see page 22
voir page 22
vease la página 22

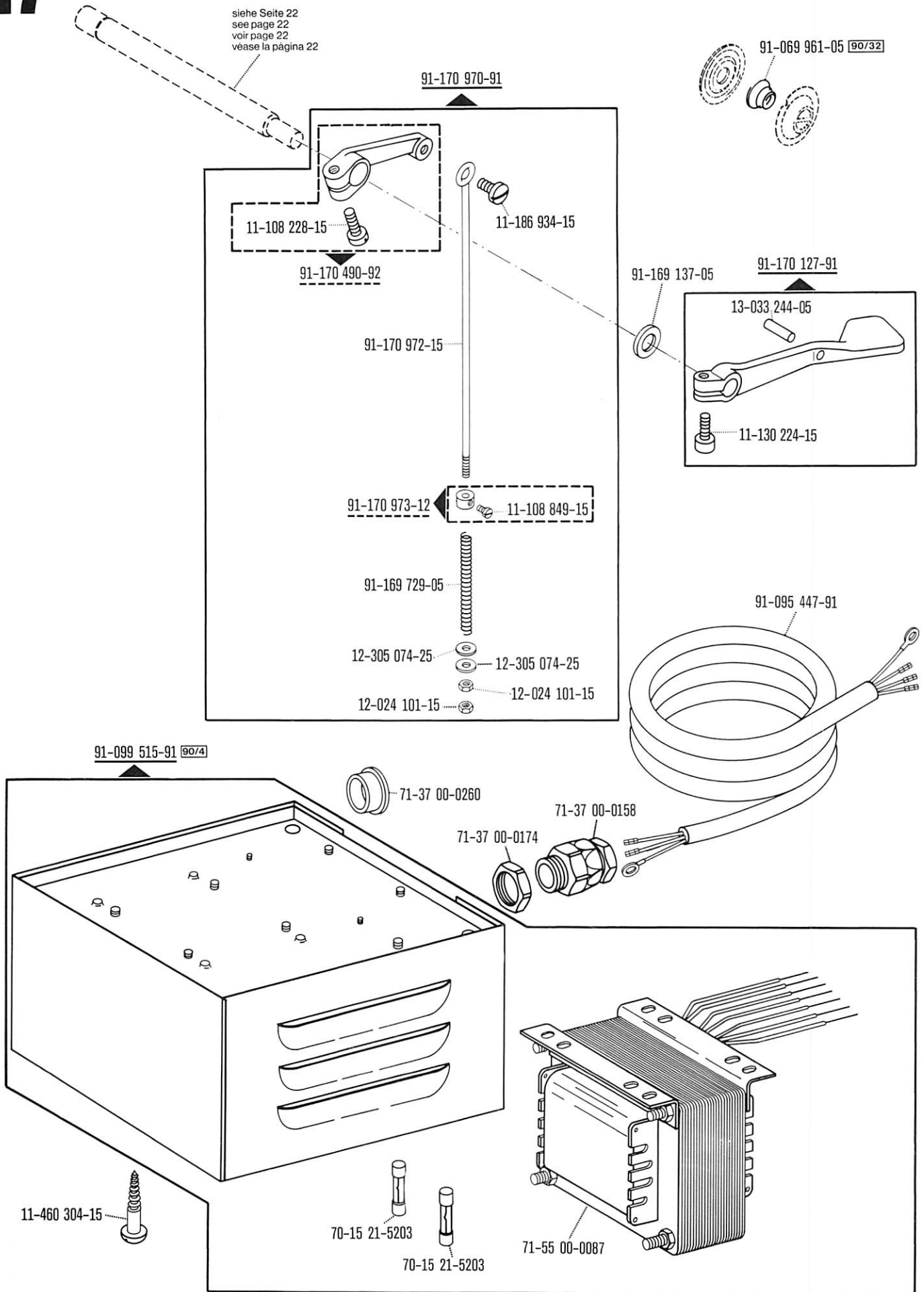

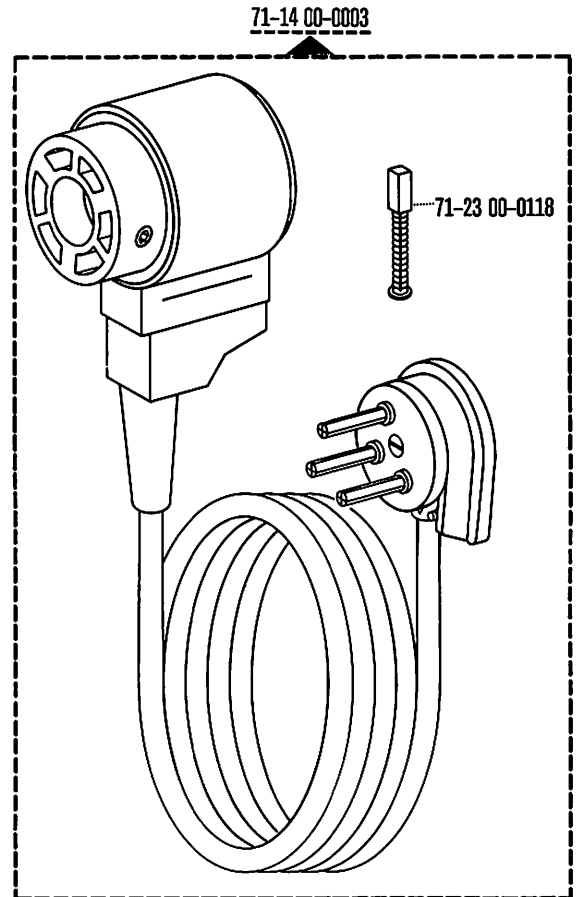
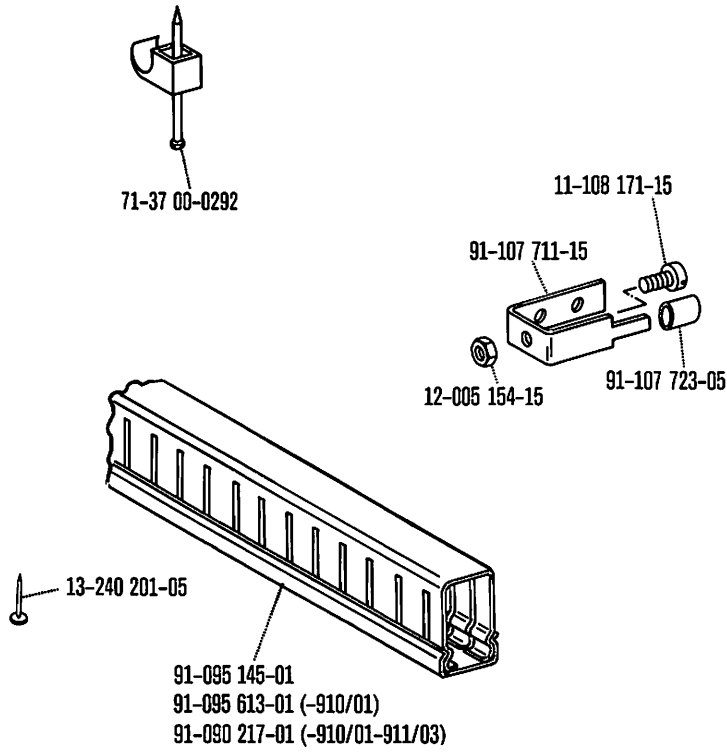

71-59 00-0274 ^{90/7} ^{90/8}

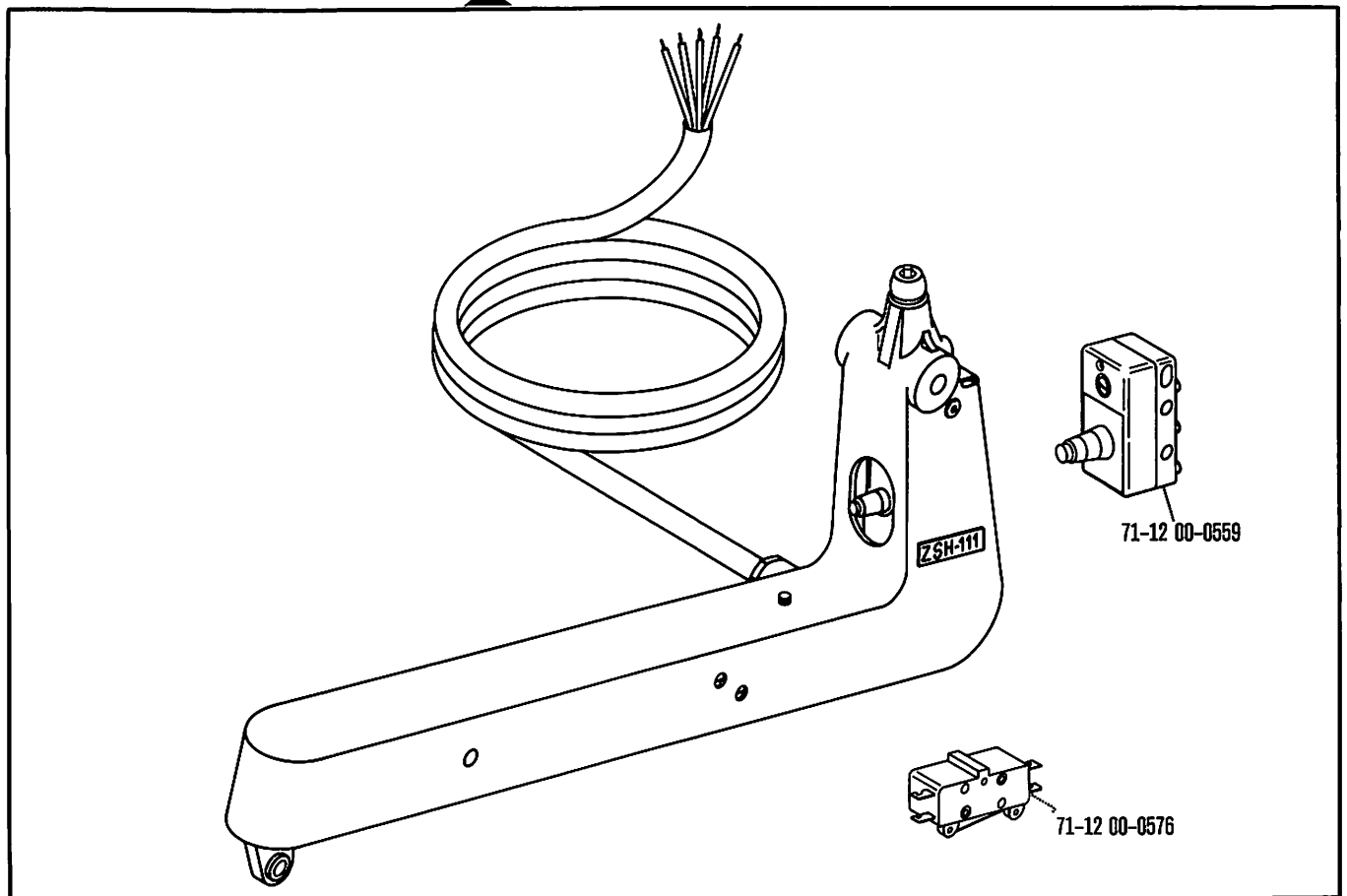

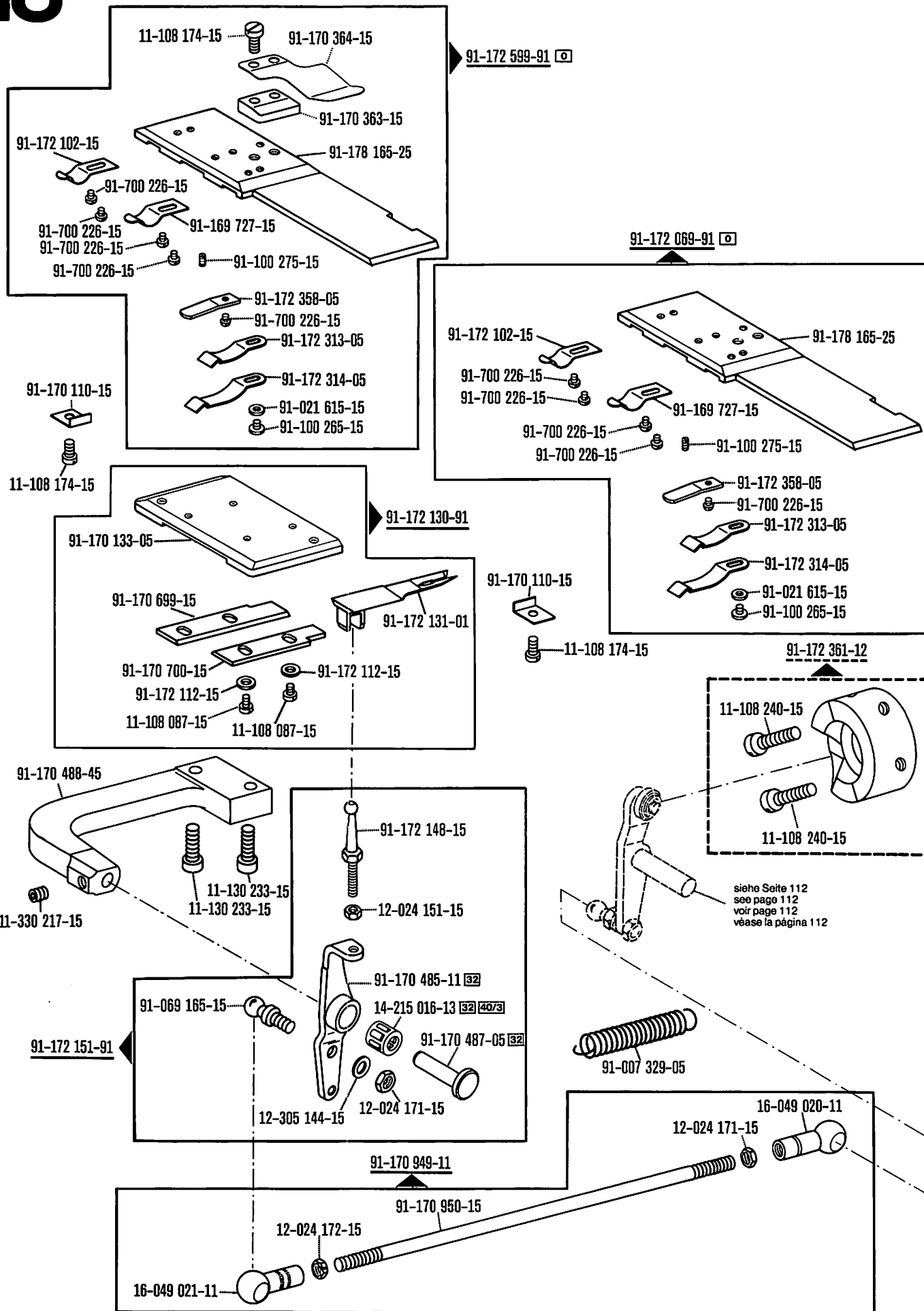

siehe Seite 112
see page 112
voir page 112
véase la página 112

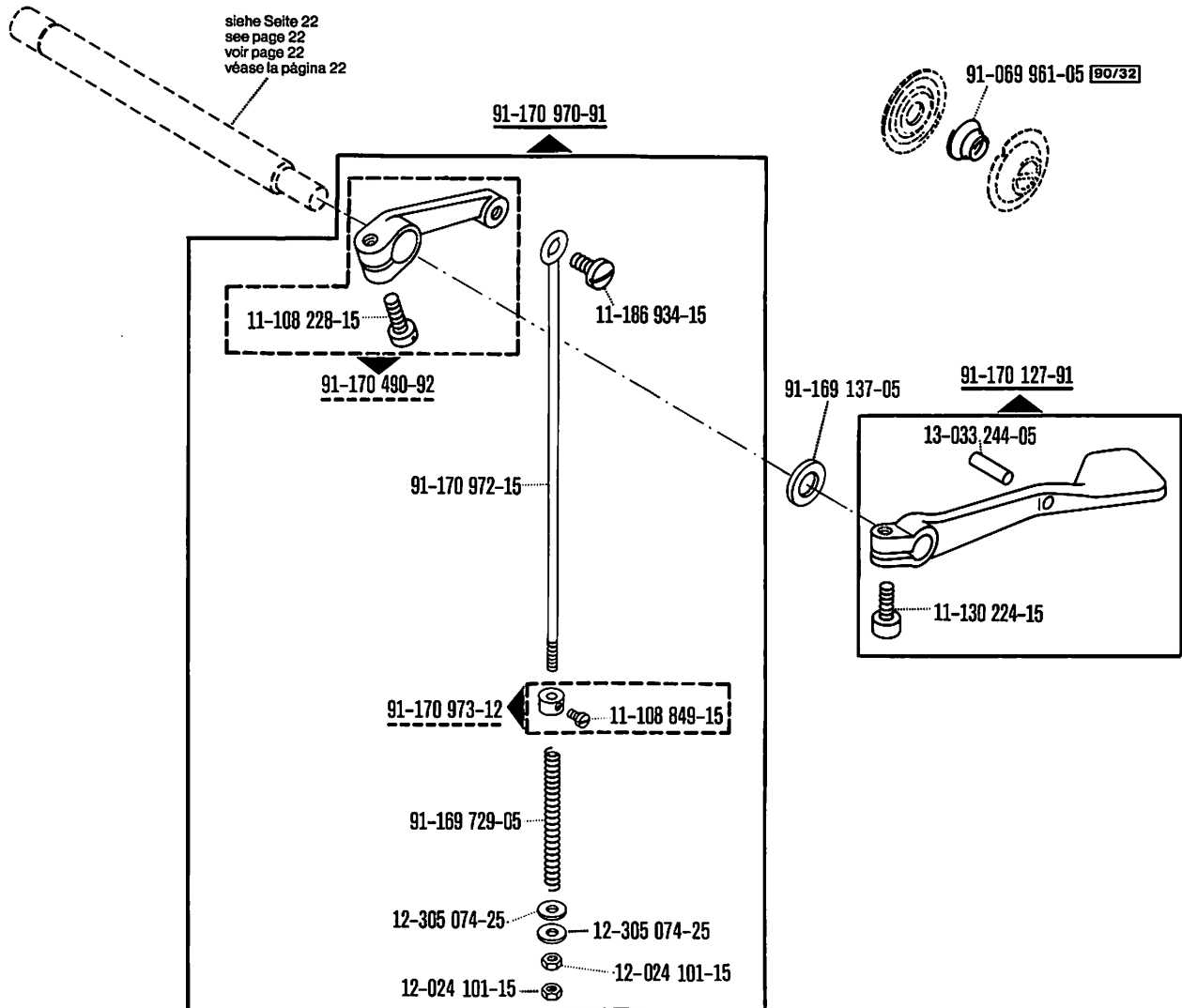

91-178 096-93 9/2 (-731/..)
9 = 2,5 - 10,0 mm

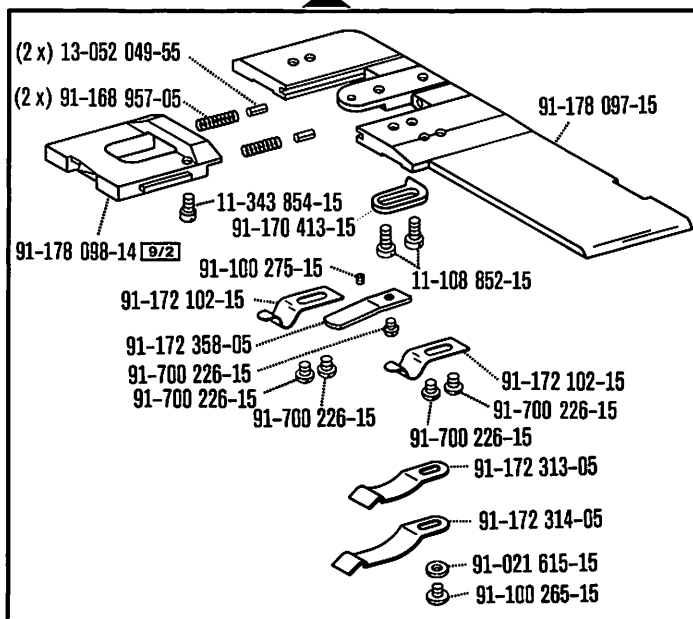

91-178 185-91 (-911/..) 9

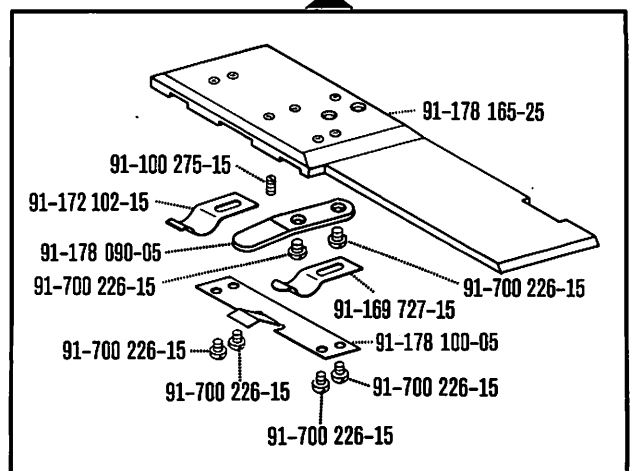

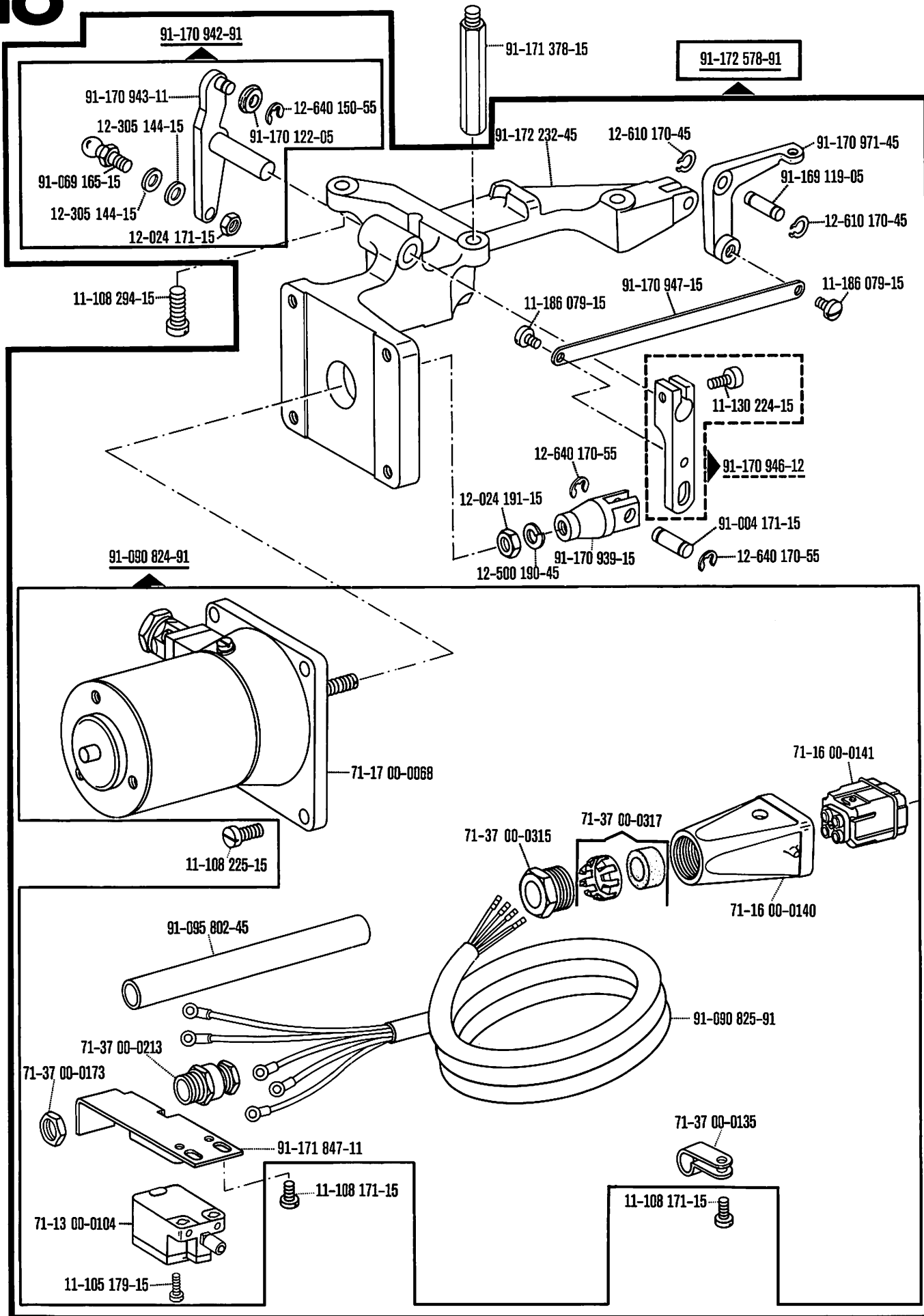

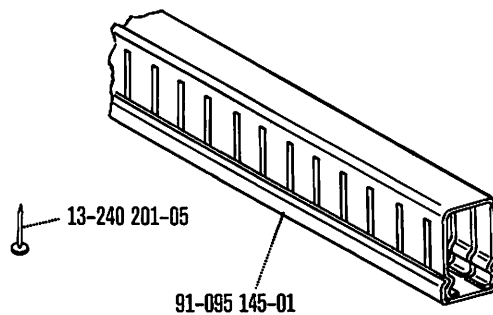
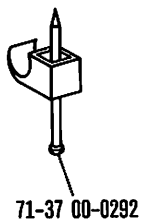
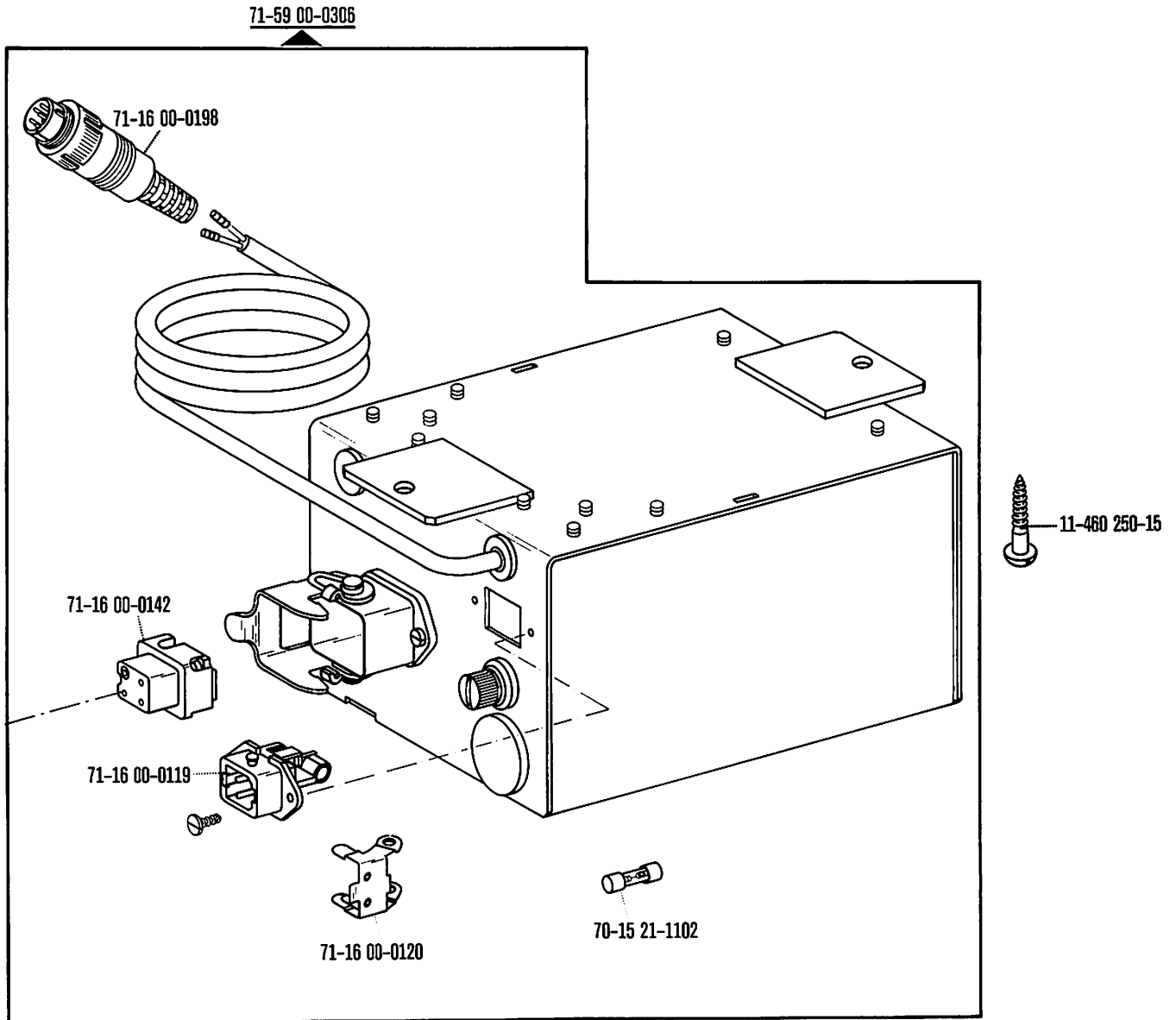

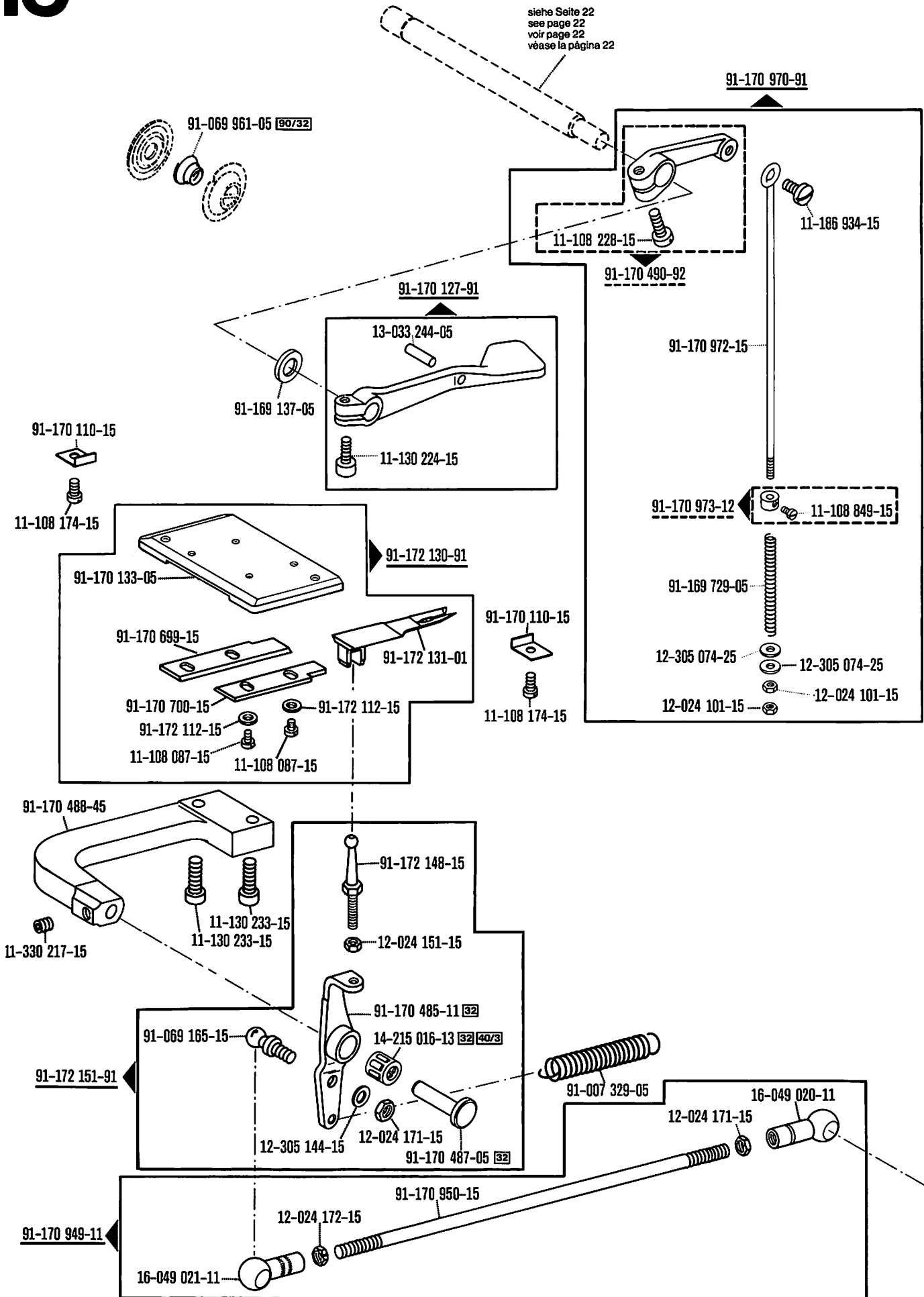

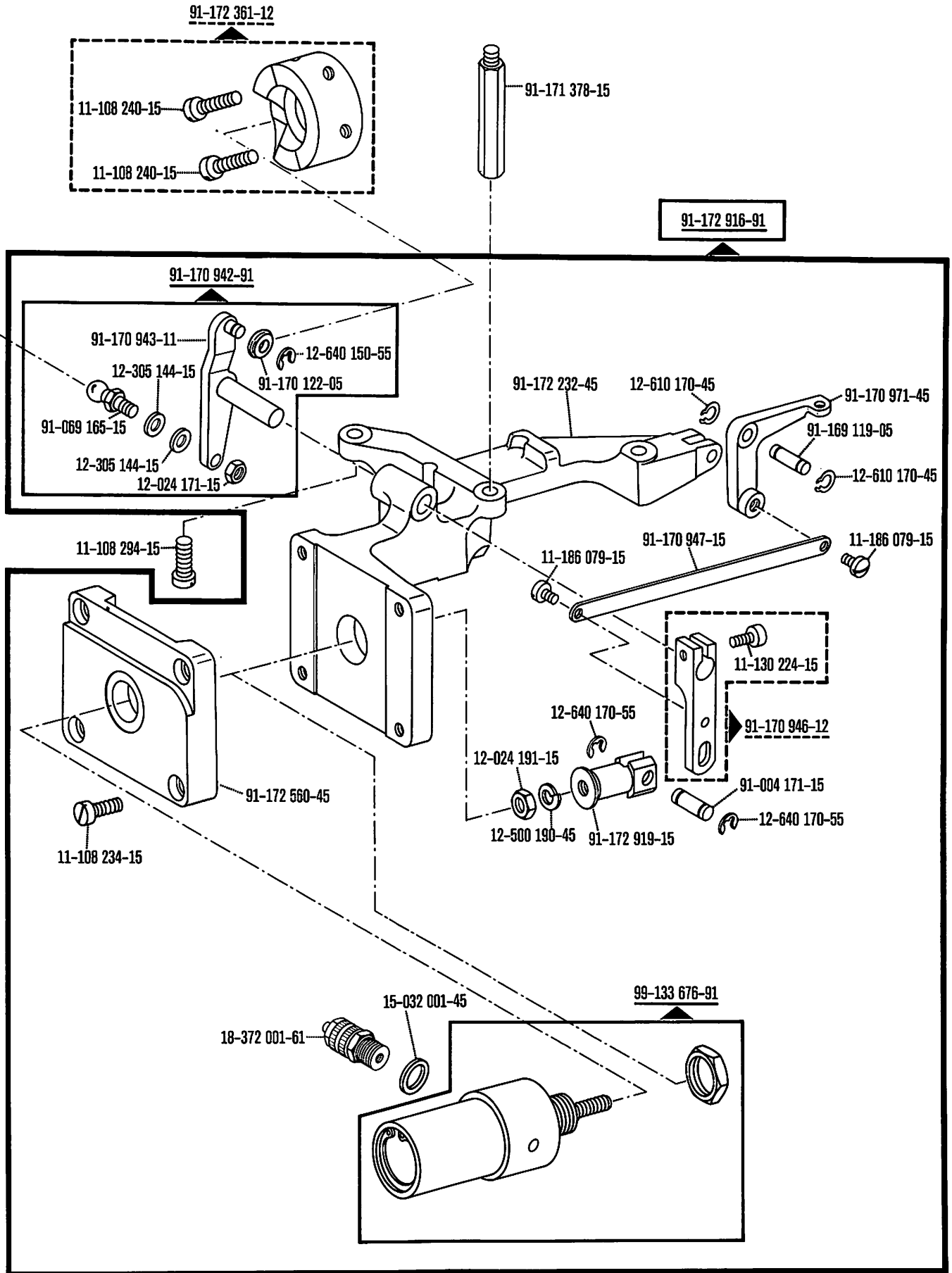

HO-814/02-45/02

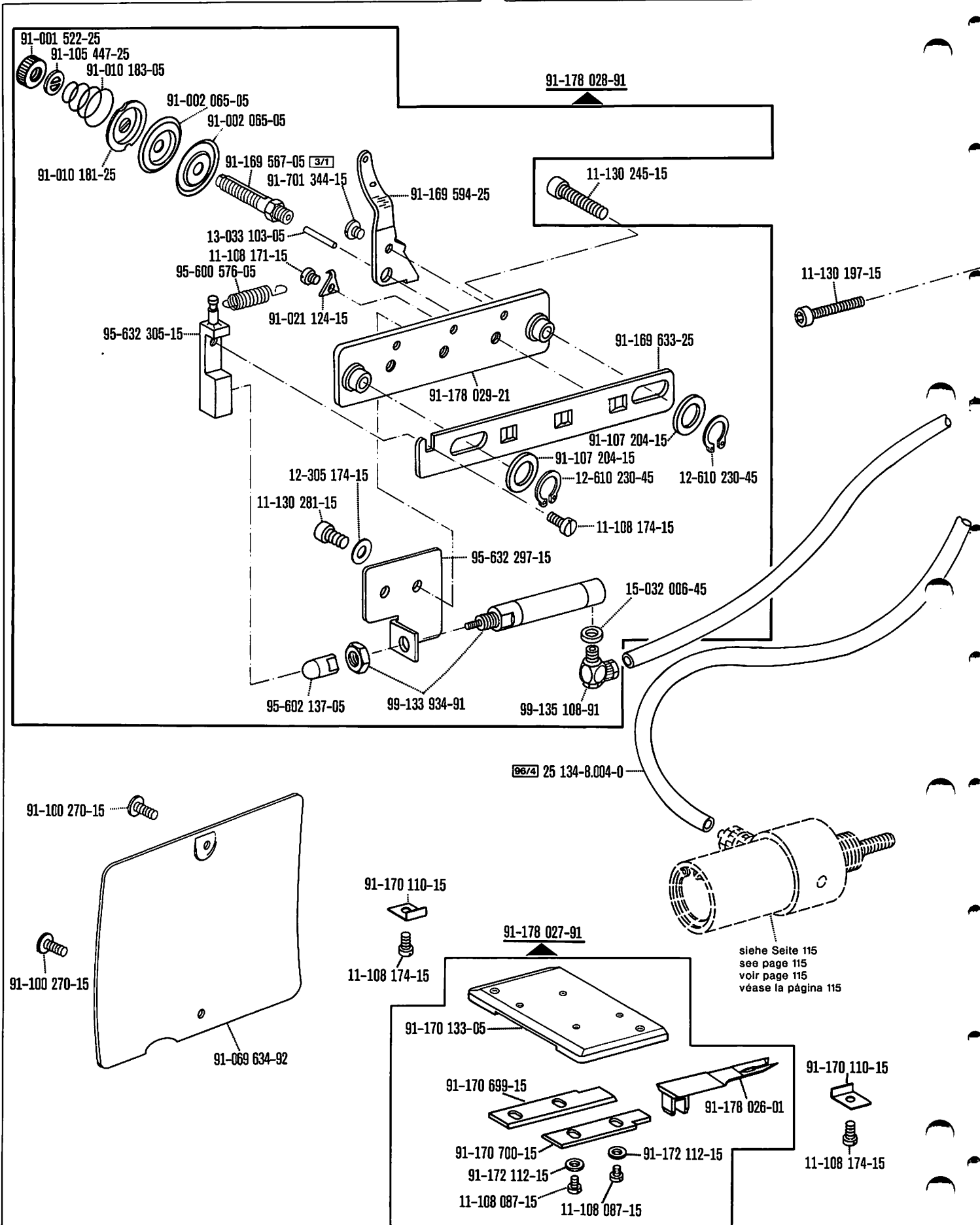

siehe Seite 115
 see page 115
 voir page 115
 véase la página 115

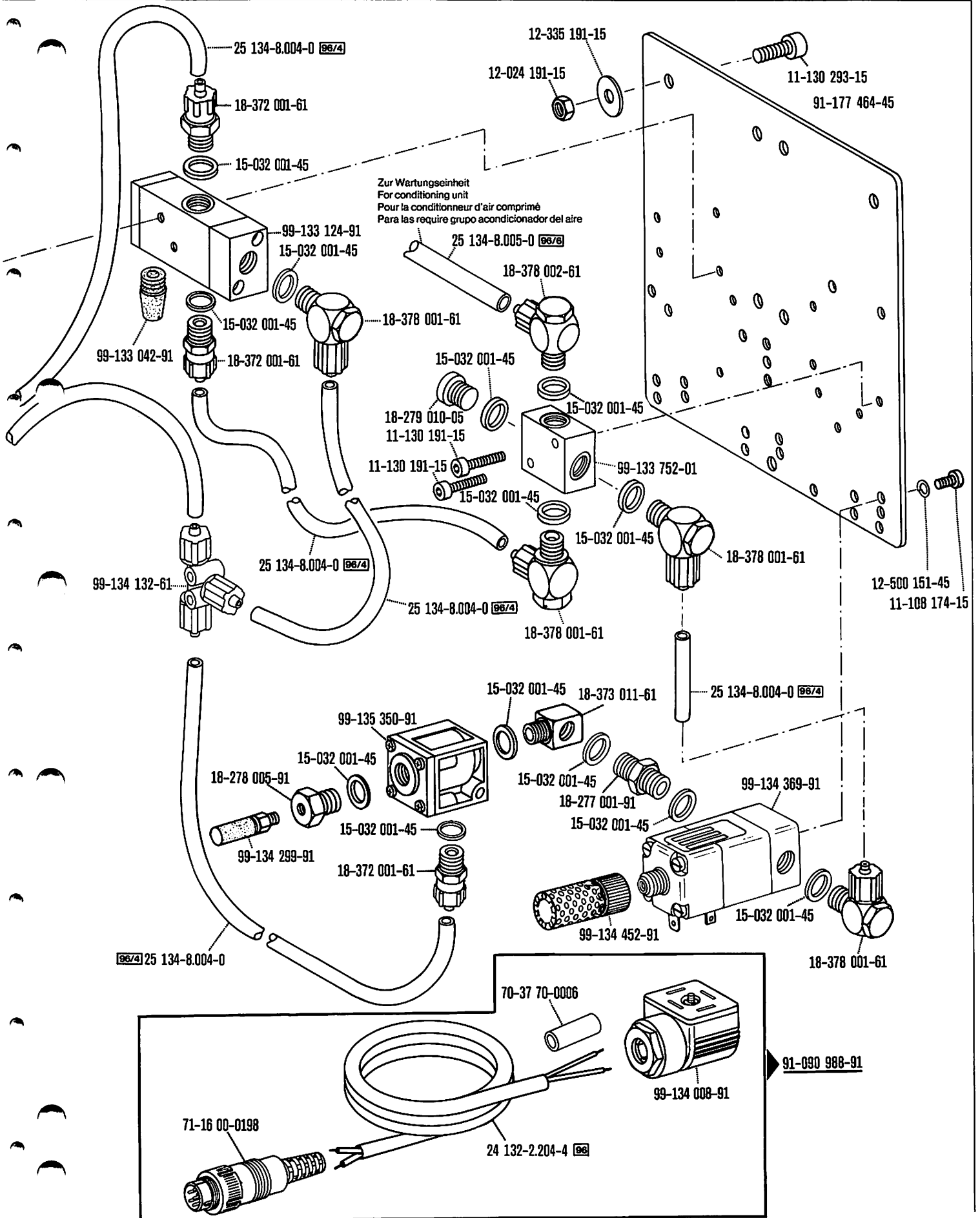

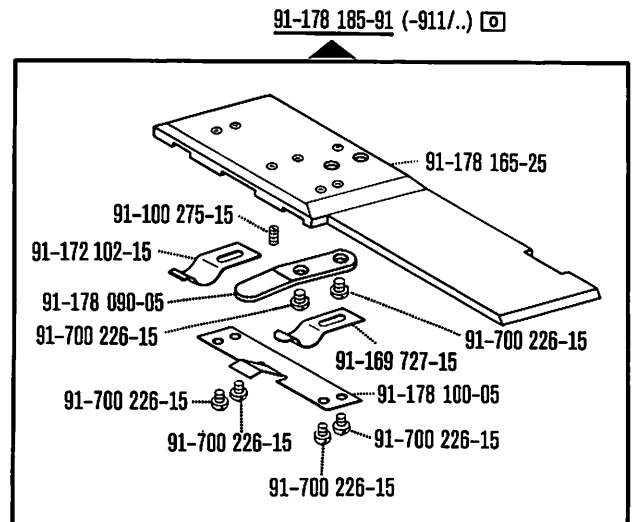
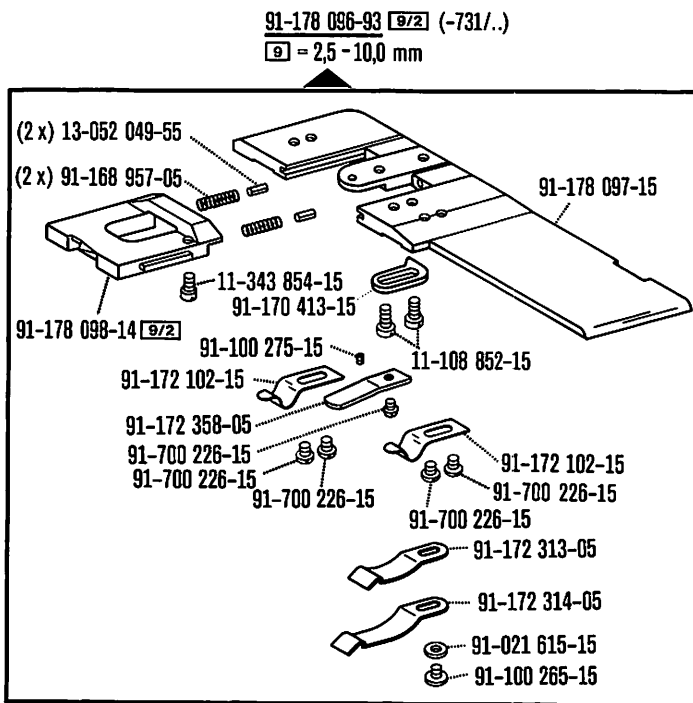
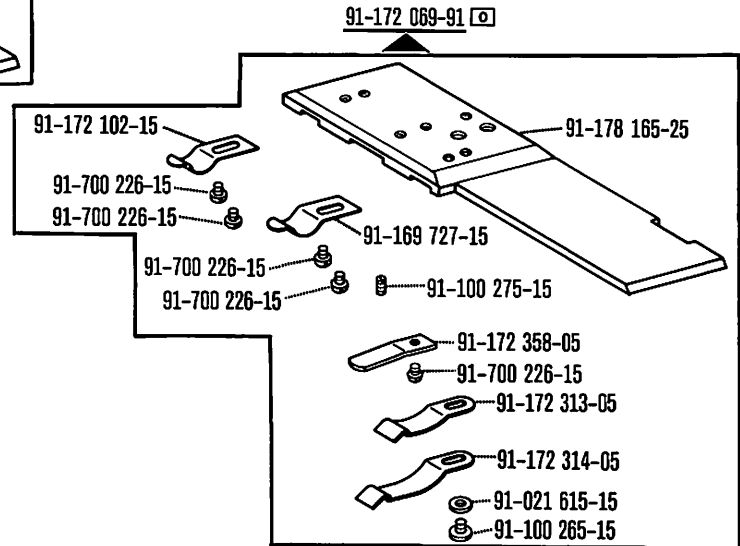
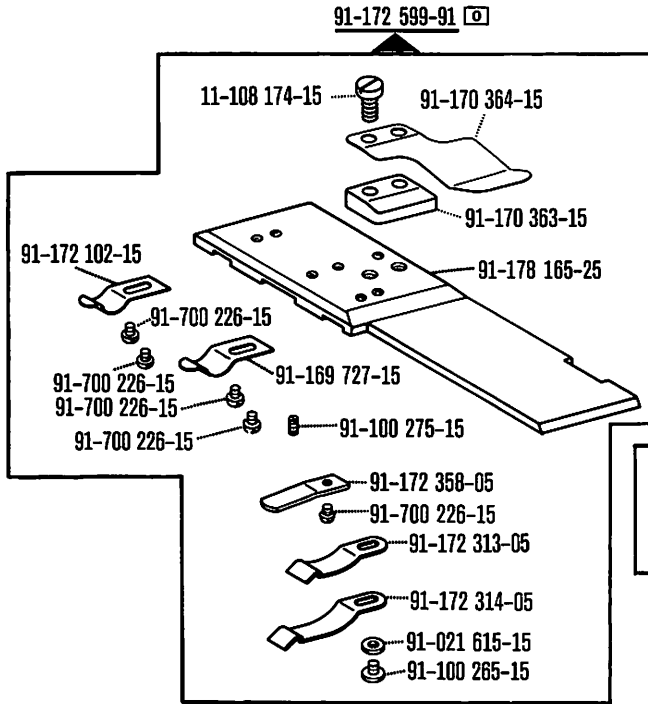

Fadenabschneid-Einrichtung
Thread trimmer
Coupe-fil
Cortahilos

-900/71 zur · pour
 for · para **Pfaff 5483**

Wartungseinheit -925/02 erforderlich
 Conditioning unit -925/02 required
 Conditionneur d'air comprimé -925/02 nécessaire
 Requiere grupo acondicionador del
 aire comprimido -925/02

9.85

19

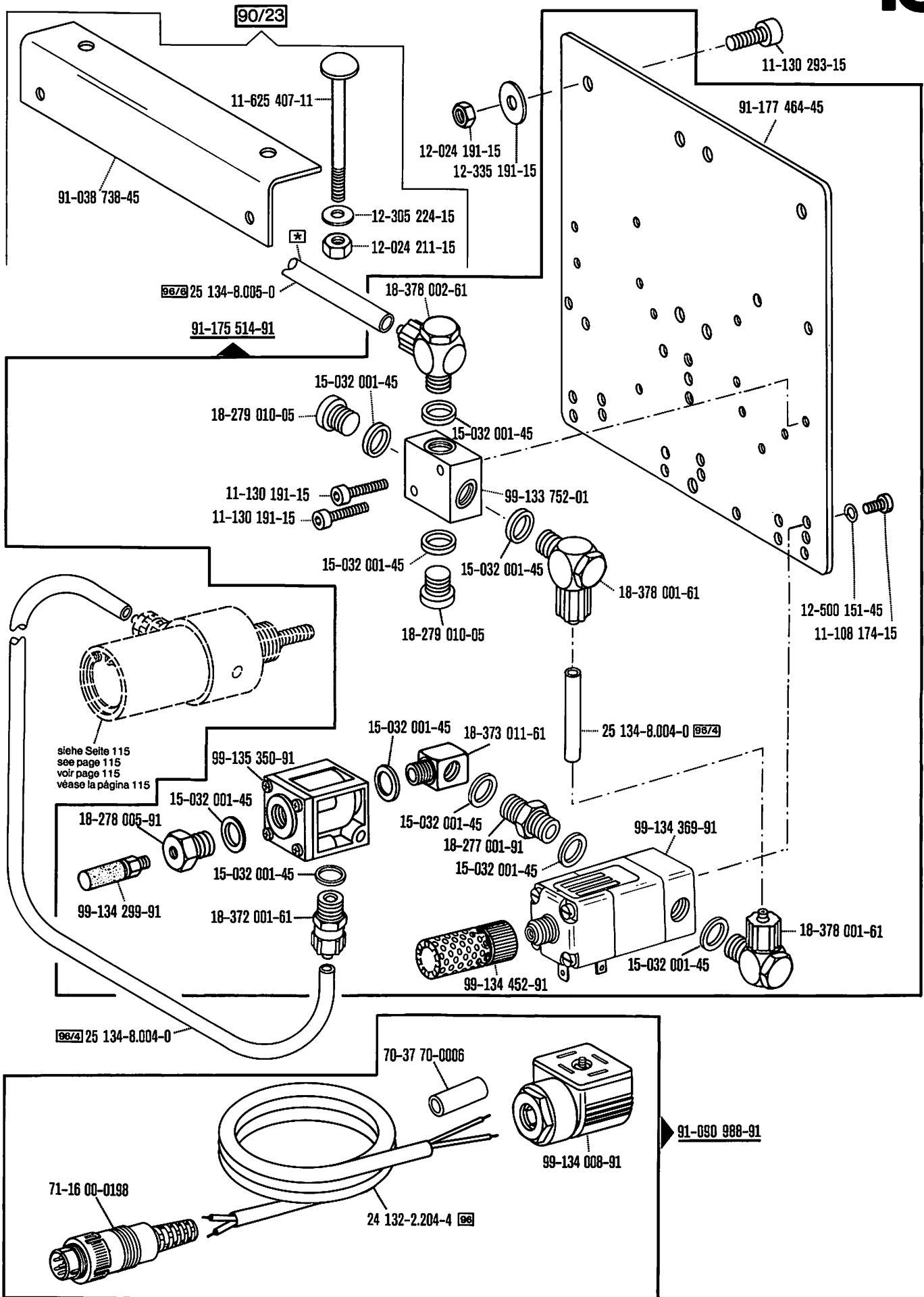

00-000 000-00 00-000 000-00 00-000 000-00

□ siehe Erläuterungen Register O
 see explanations on section O
 voir légende registre O
 ver explicaciones del registro O

* Zur Wartungseinheit
 For conditioning unit
 Pour la conditionneur d'air comprimé
 Para las require grupo acondicionador del aire

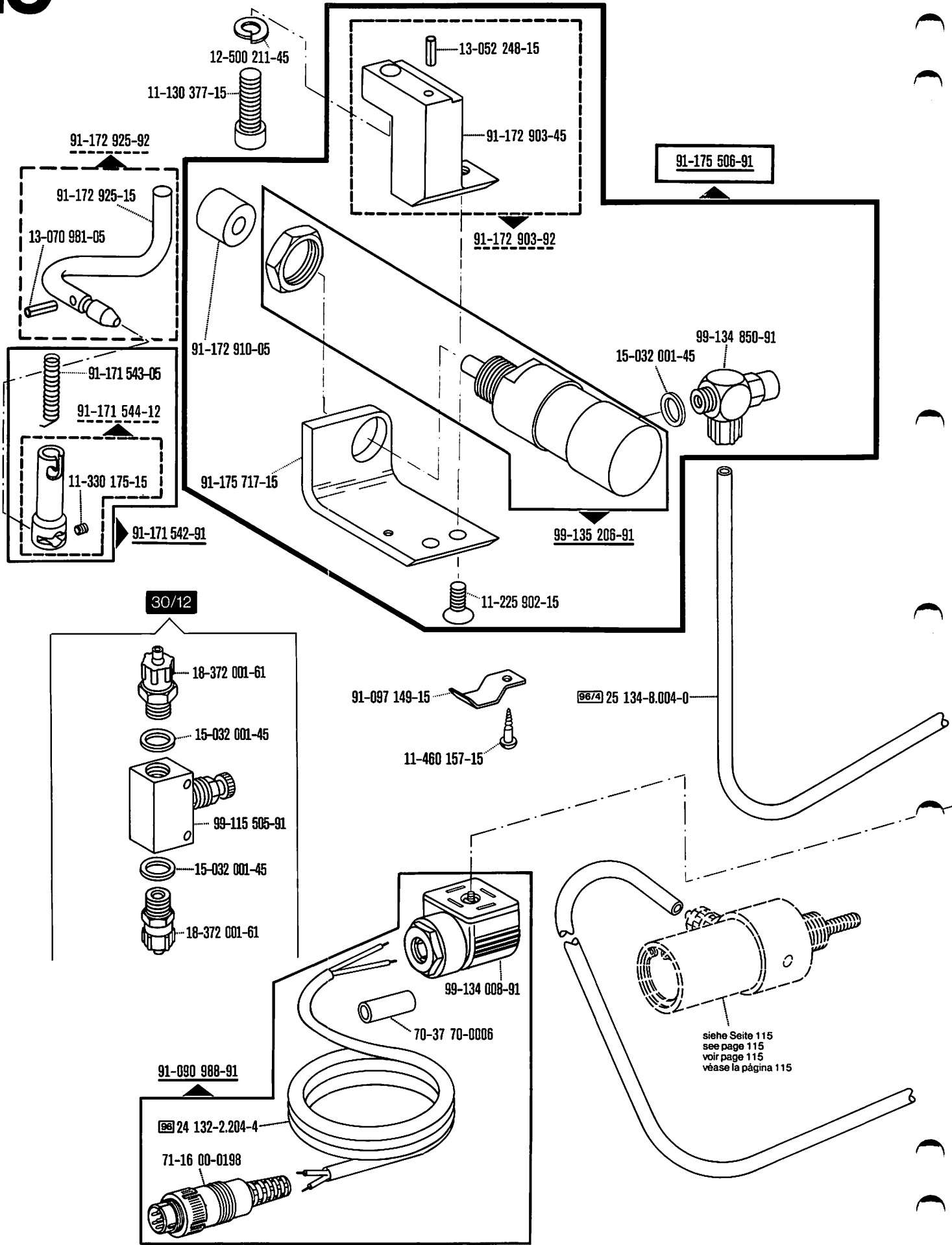

Fadenabschneid-Einrichtung
Thread trimmer
Coupe-fil
Cortahilos

-900/71-910/04*) zur · pour
for · para Pfaff 5483

Wartungseinheit -925/02 erforderlich
Conditioning unit -925/02 required
Conditionneur d'air comprimé -925/02 nécessaire
Requiere grupo acondicionador del
aire comprimido -925/02

9.85

19

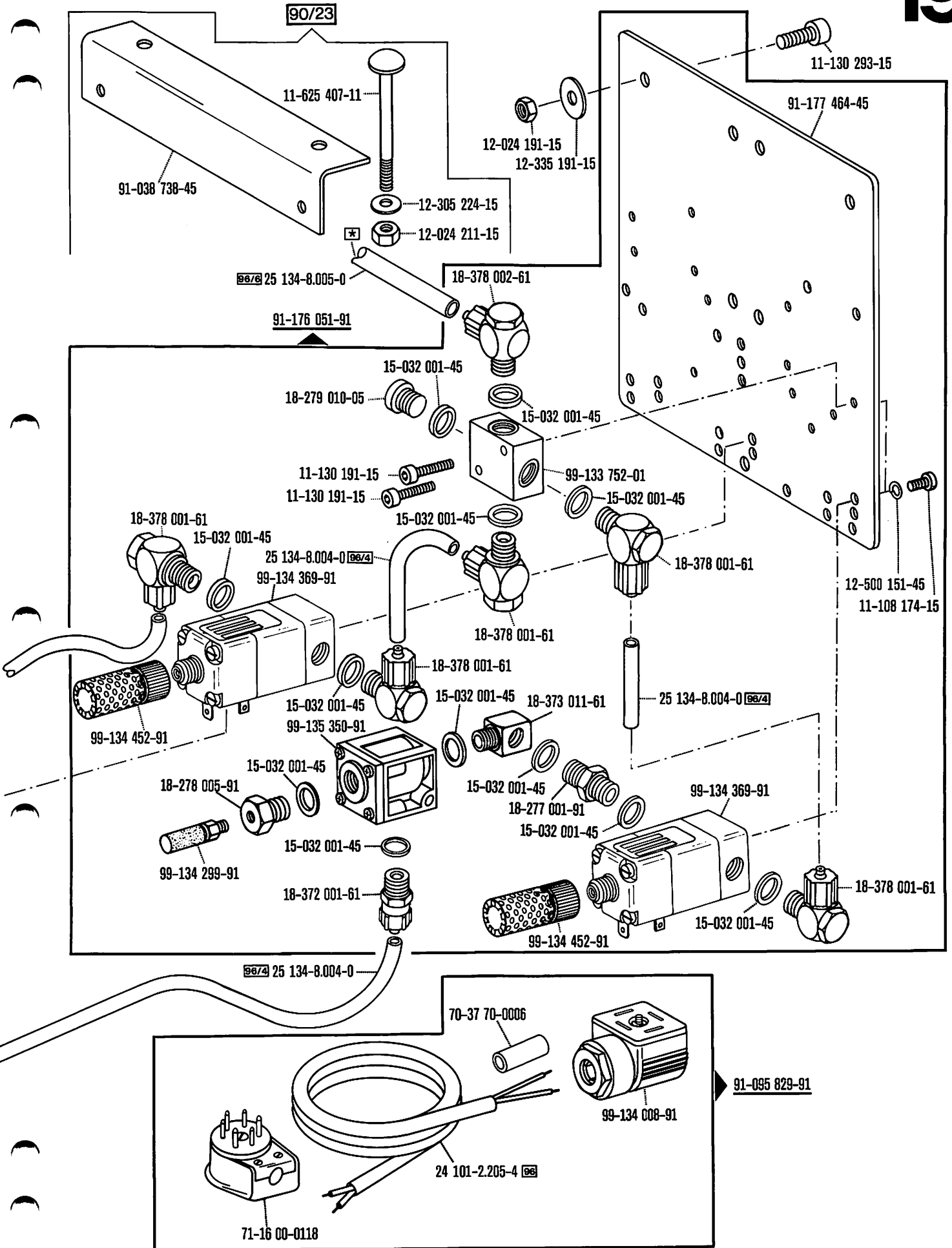

00-000 000-00 00-000 000-00 00-000 000-00

☐ siehe Erläuterungen Register O
see explanations on section O
voir légende registre O
ver explicaciones del registro O

*) Presserfuß-Automatik
Automatic presser foot lifter
Relève-pied automatique
Alzaprensataelas

☐ Zur Wartungseinheit
For conditioning unit
Pour la conditionneur d'air comprimé
Para las require grupo acondicionador del aire

Fadenspannungs-Steuerung
Thread tension control
Commande de la tension du fil
Control de la tensión del hilo superior

-906/02 zur · pour
for · para Pfaff 5483

9.85

20

91-170 741-91

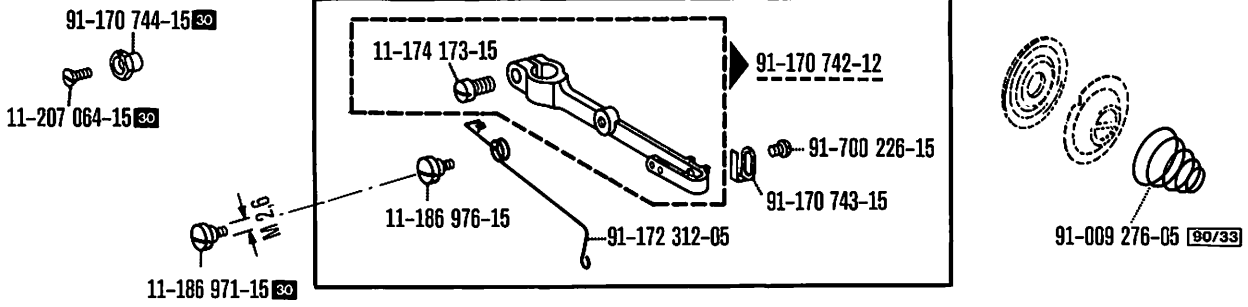

Presserfuß-Automatik
Automatic presser foot lifter
Relève-pied automatique
Alzaprensatelas

-910/01 zur · pour
for · para Pfaff 5483-900/11

9.85

21

71-59 00-0242 (Quick-PFA 54)

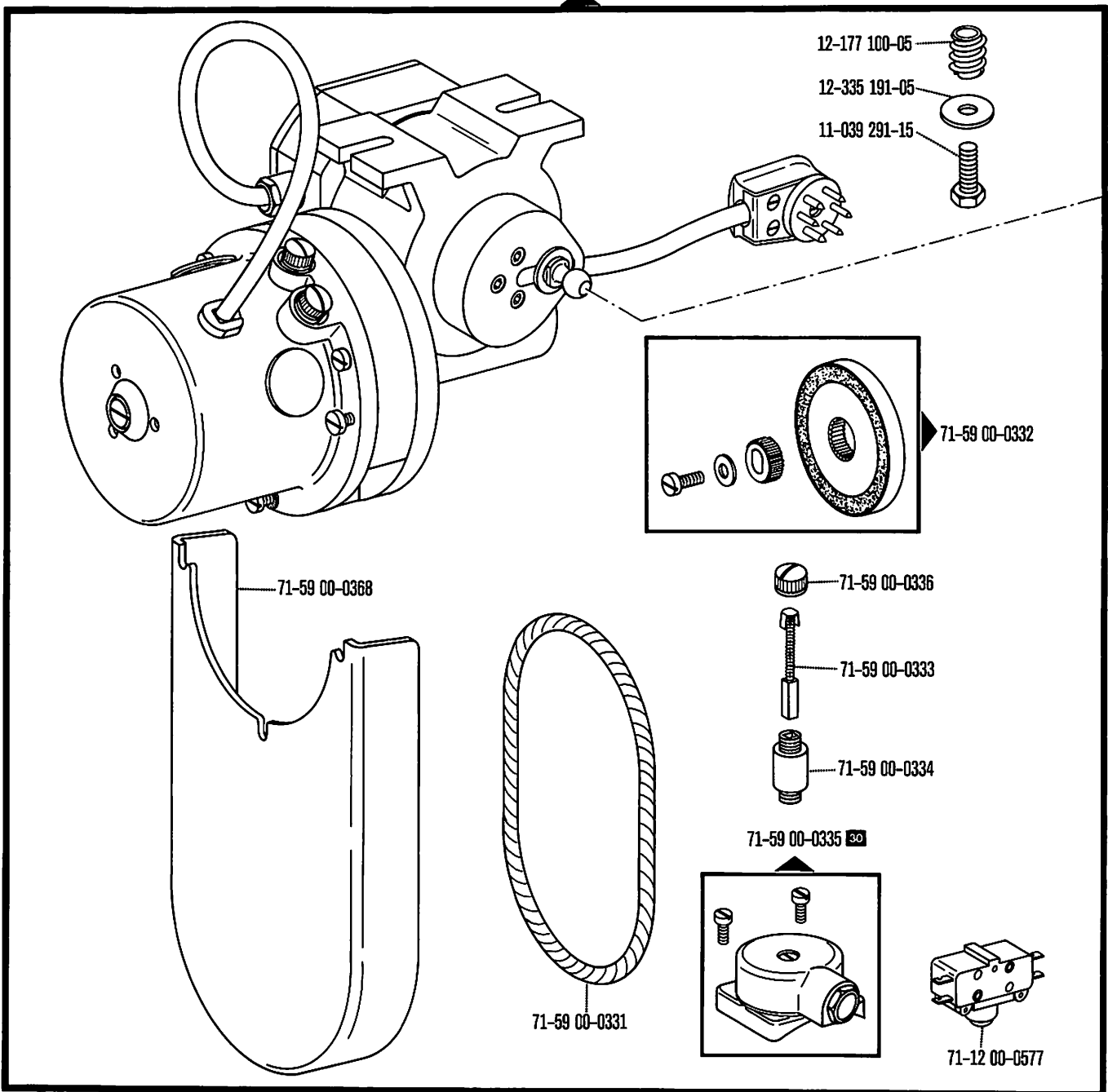

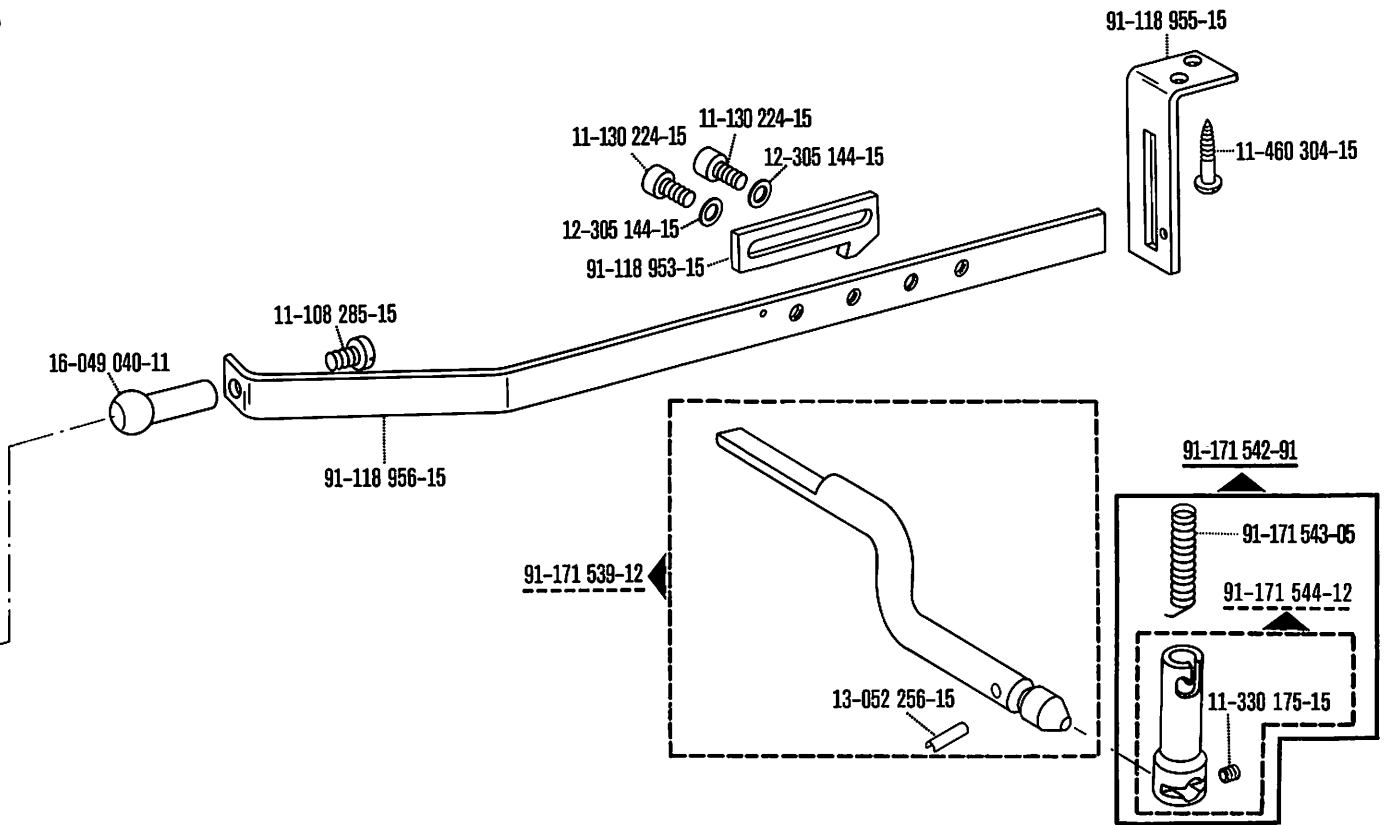

Schnurscheiben-Tabelle · Table of Pulleys

Tableau des poulies à gorge · Tabla de poleas acanaladas

Teilenummer Part number Numéros des pièces № de las piezas	Motordrehzahl U/min. Motor speed (r. p. m.) Régime moteur trs/mn Regimen del motor en r. p. m.	Frequenz Frequency Fréquence Frecuencia	Schnurscheiben-Durchmesser ¹⁾ in mm Pulley dia. ¹⁾ (mm) Diamètre effectif de la poulie en mm Diámetro efectivo de la polea en mm
71-59 00-0098	1400	50 Hz (c/s)	86
	1700	60 Hz (c/s)	86
71-59 00-0089	2800	50 Hz (c/s)	56
	3400	60 Hz (c/s)	56

71-59 00-0265 (Quick)

71-59 00-0264 (Pfaff)

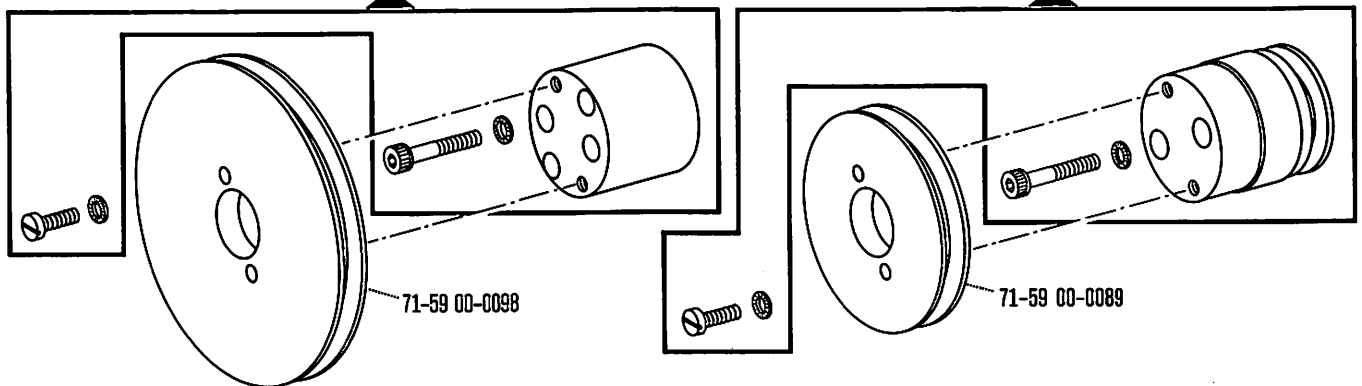

 siehe Erläuterungen Register O
see explanations on section O
voir légende registre O
ver explicaciones del registro O

¹⁾ Wirksamer Durchmesser
Effective diameter
Diamètre effectif
Diámetro efectivo

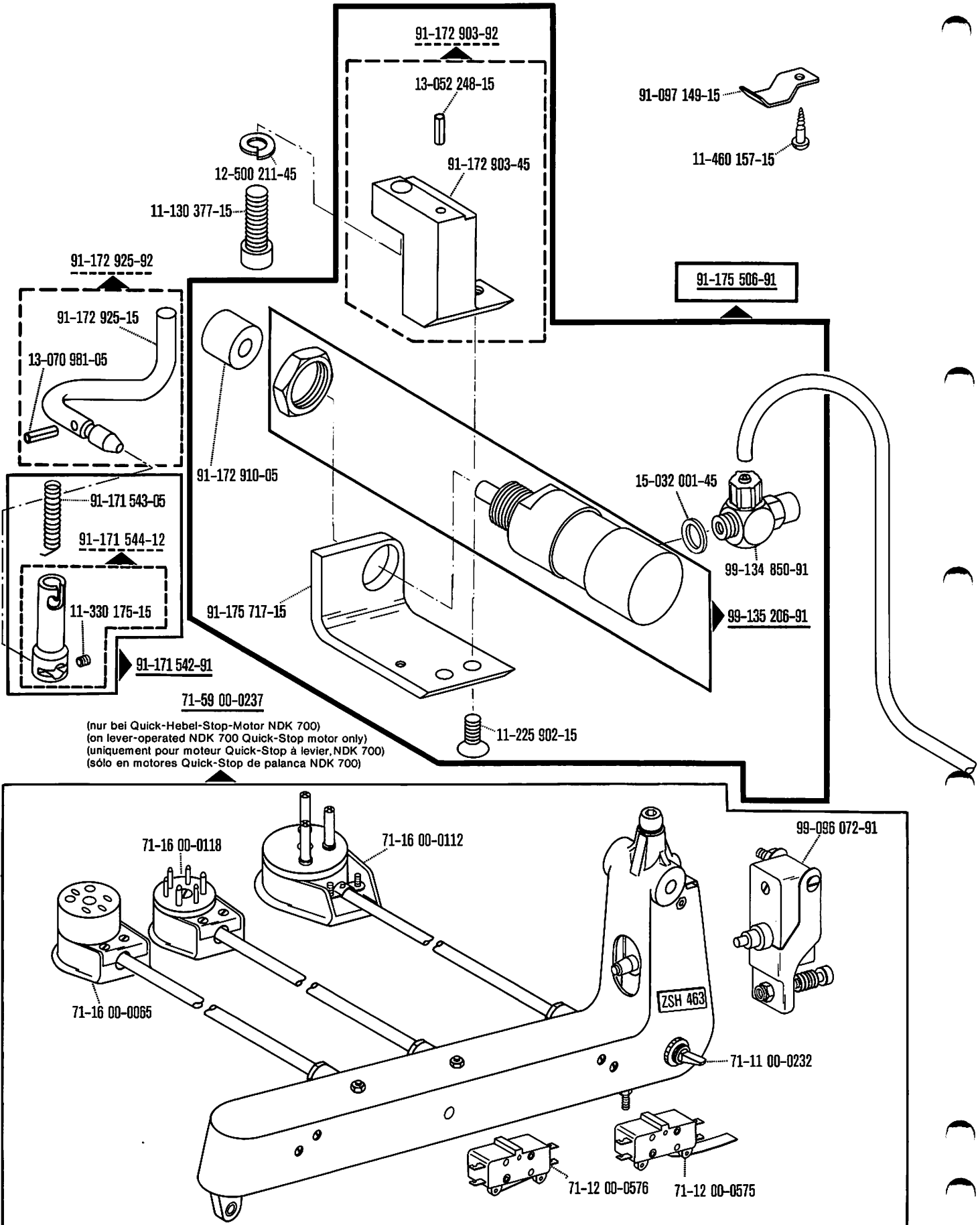

Presserfuß-Automatik
Automatic presser foot lifter
Relève-pied automatique
Alzaprensatelas

-910/04

zur / pour
 for / para **Pfaff 5483**

Wartungseinheit -925/02 erforderlich
 Conditioning unit -925/02 required
 Conditionneur d'air comprimé -925/02 nécessaire
 Requiere grupo acondicionador del aire comprimido -925/02

9.85

22

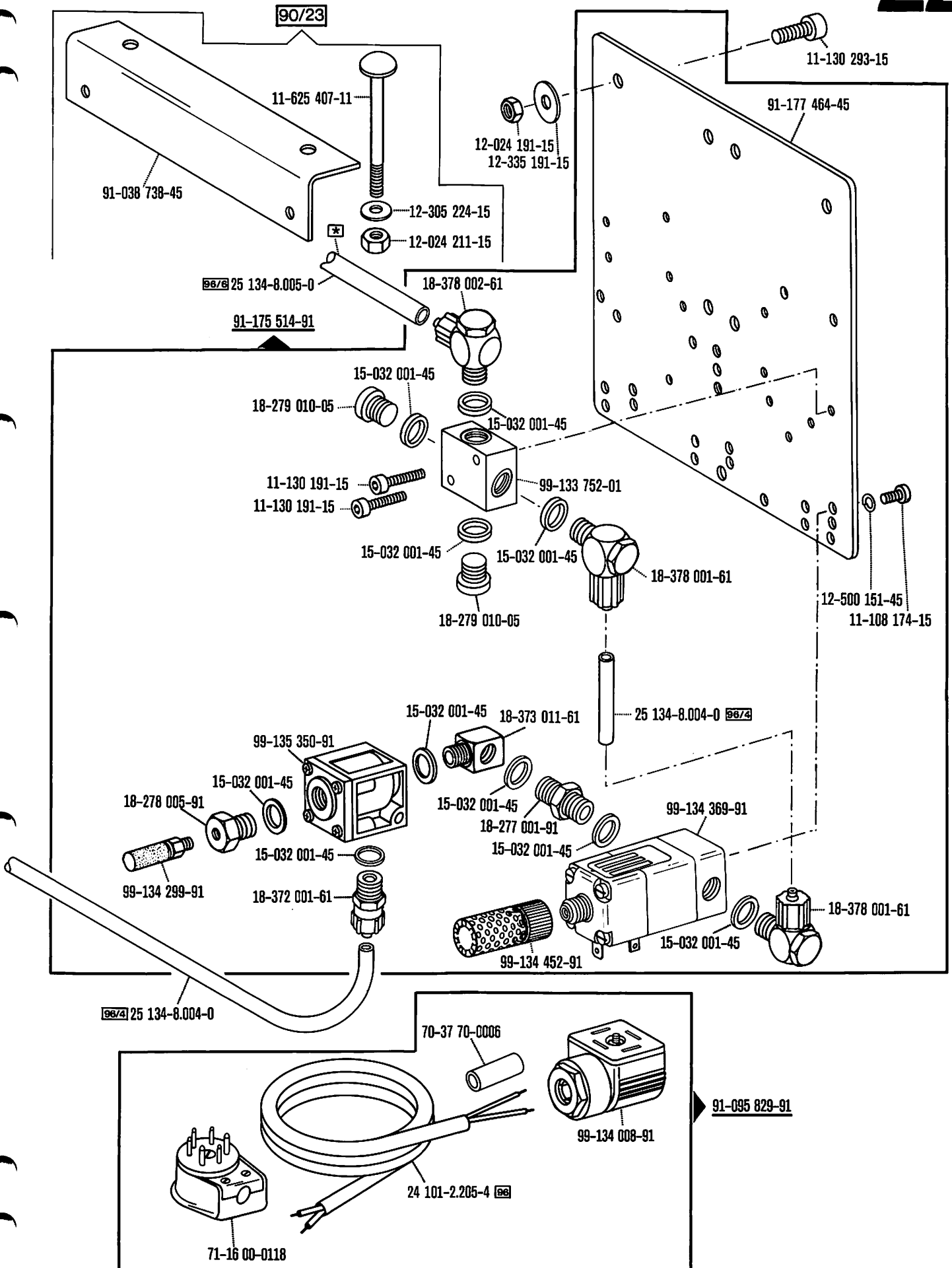

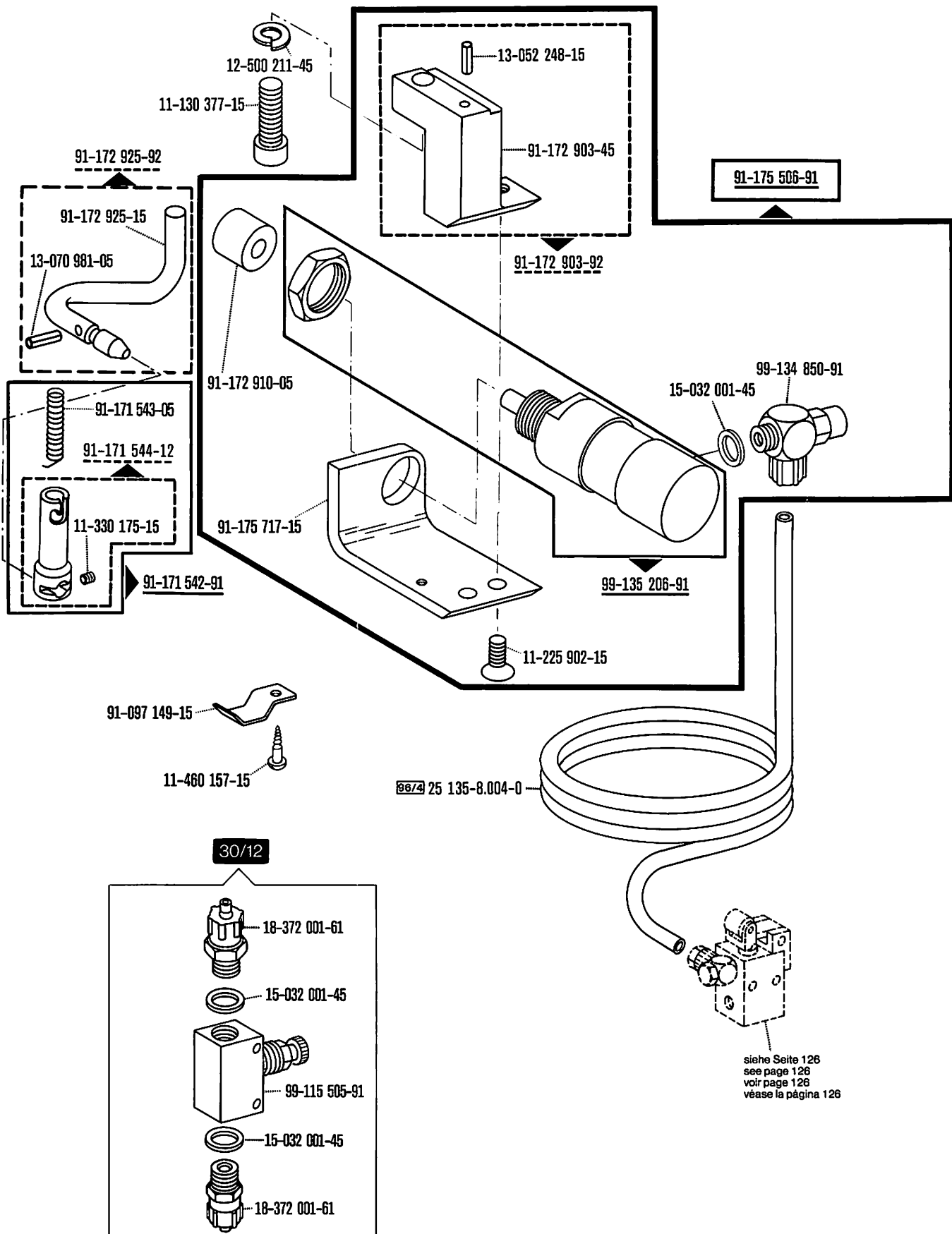

siehe Seite 126
see page 126
voir page 126
véase la página 126

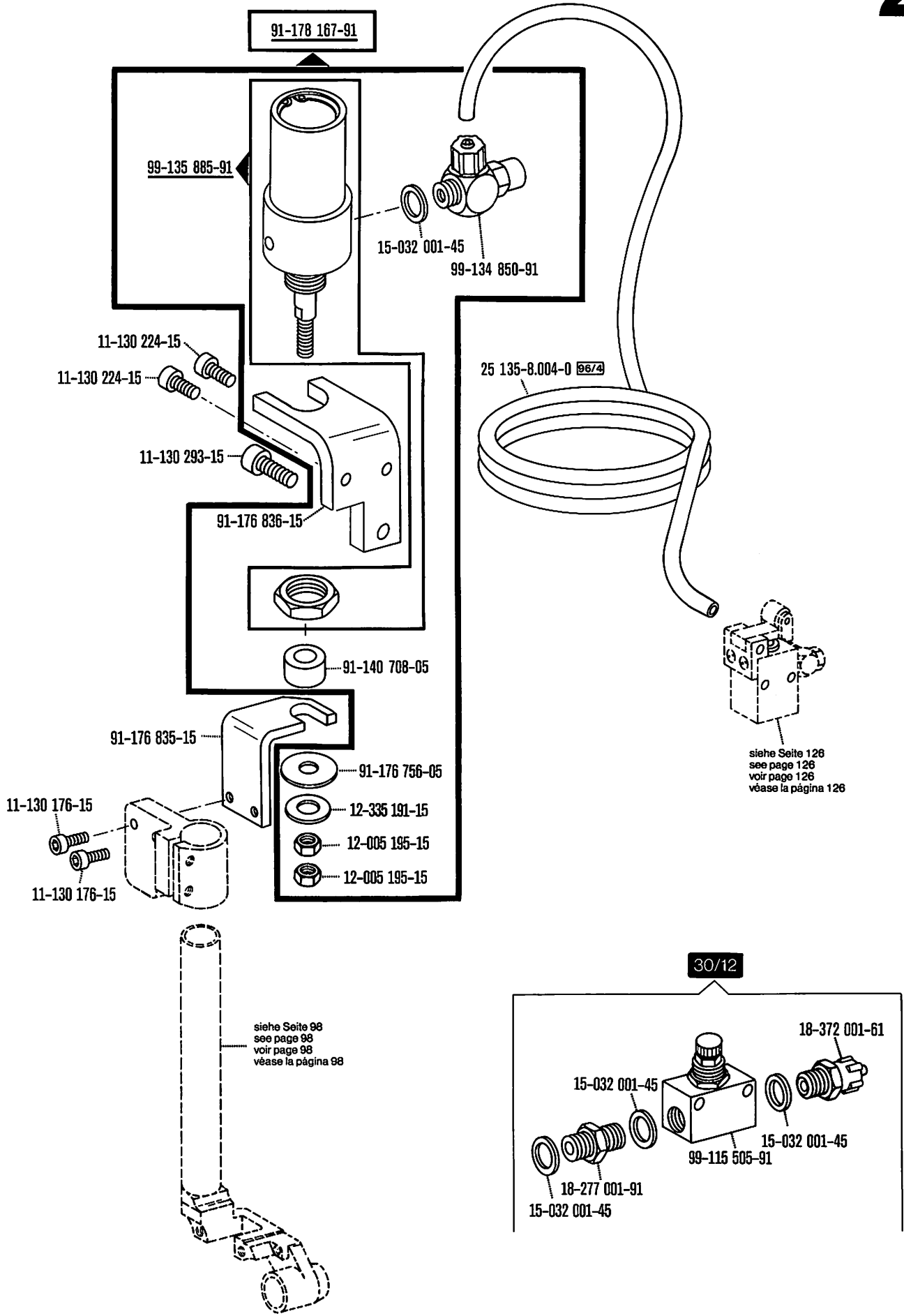

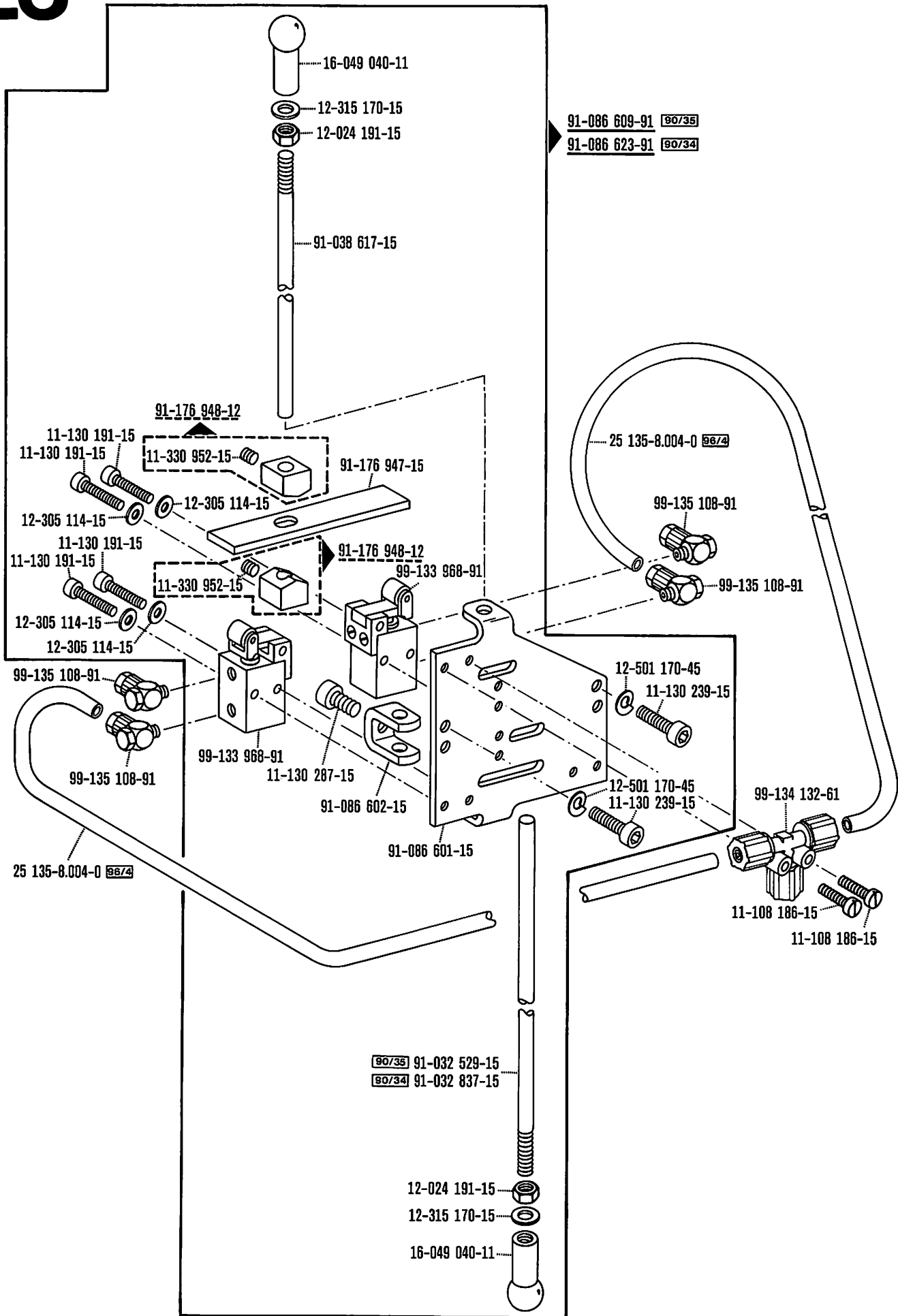

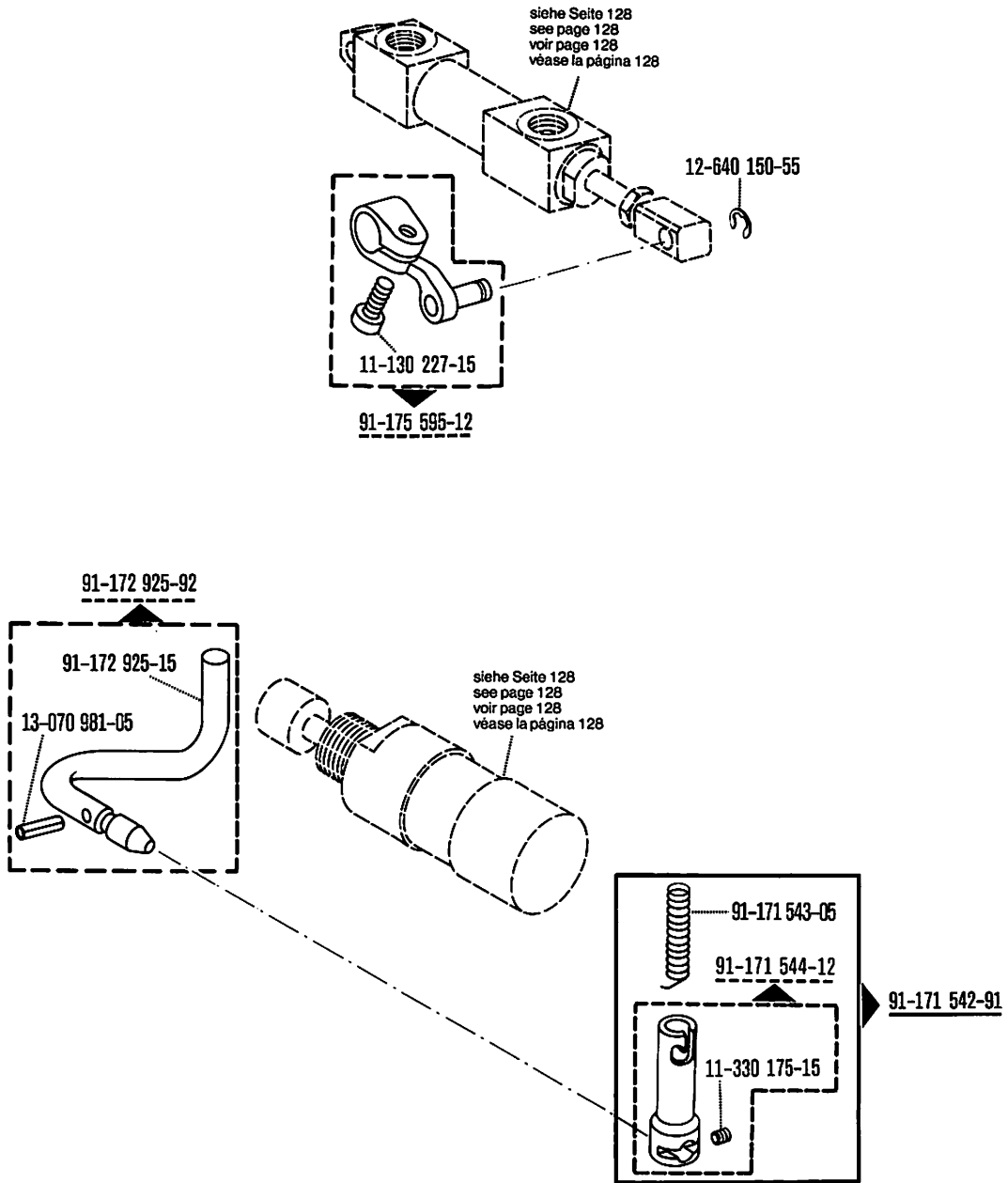

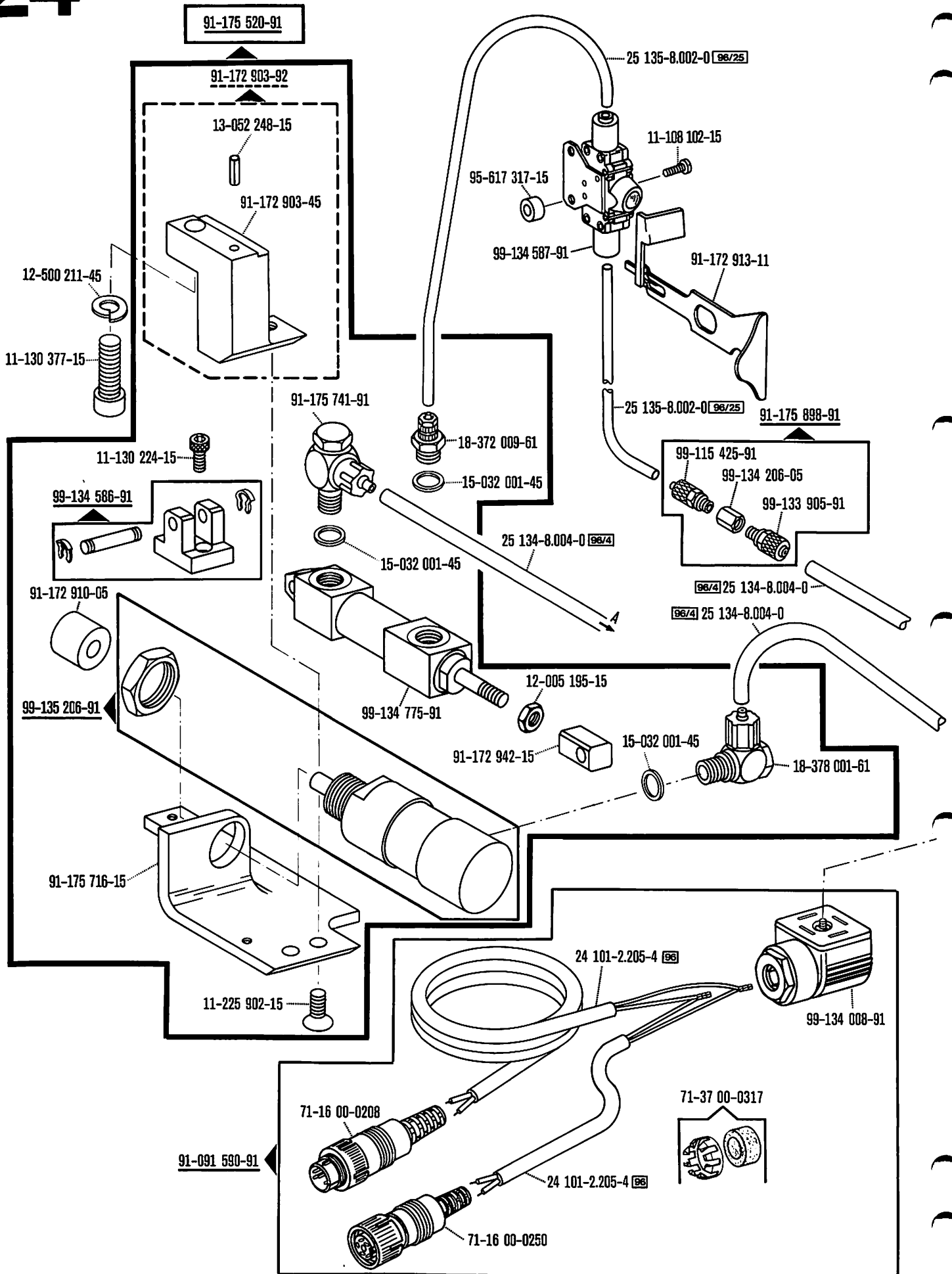

Verriegelungs-Einrichtung
 Backtacking mechanism
 Dispositif à points d'arrêt
 Rematador

-911/15*) ^{90/31} zur · pour
 -911/35*) ^{90/31} for · para Pfaff 5483 H

Wartungseinheit -925/02 erforderlich
 Conditioning unit -925/02 required
 Conditionneur d'air comprimé -925/02 nécessaire
 Requiere grupo acondicionador del
 aire comprimido -925/02

9.85

24

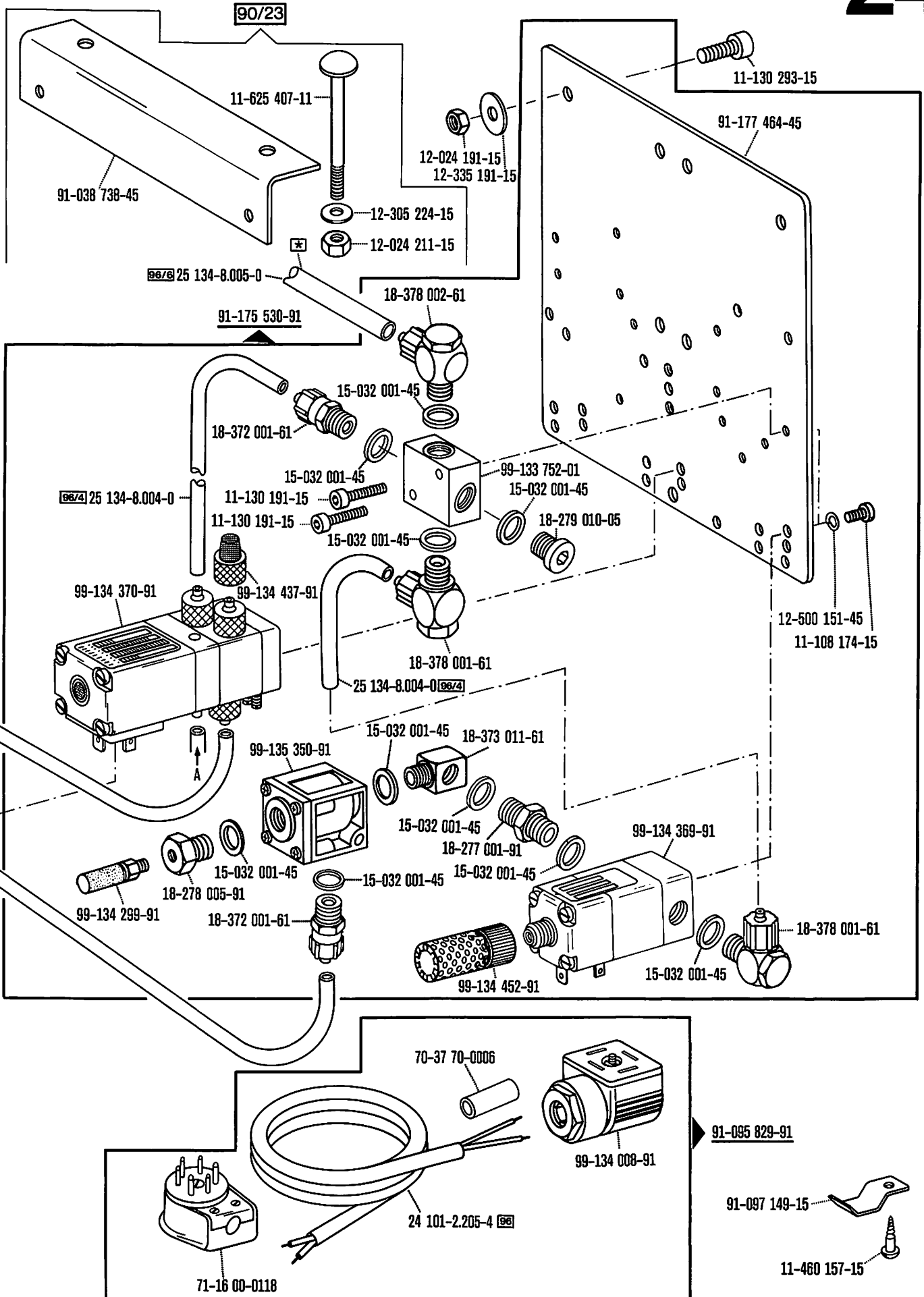

00-000 000-00 00-000 000-00 00-000 000-00

☐ siehe Erläuterungen Register O
 see explanations on section O
 voir légende registre O
 ver explicaciones del registro O

*) Beinhaltet Presserfußautomatik -910/04
 With automatic presser foot lifter -910/04
 Relève-pied compris. -910/04
 Alzaprensateelas automático -910/04

* Zur Wartungseinheit
 For conditioning unit
 Pour la conditionneur d'air comprimé
 Para las require grupo acondicionador del aire

91-092 210-91

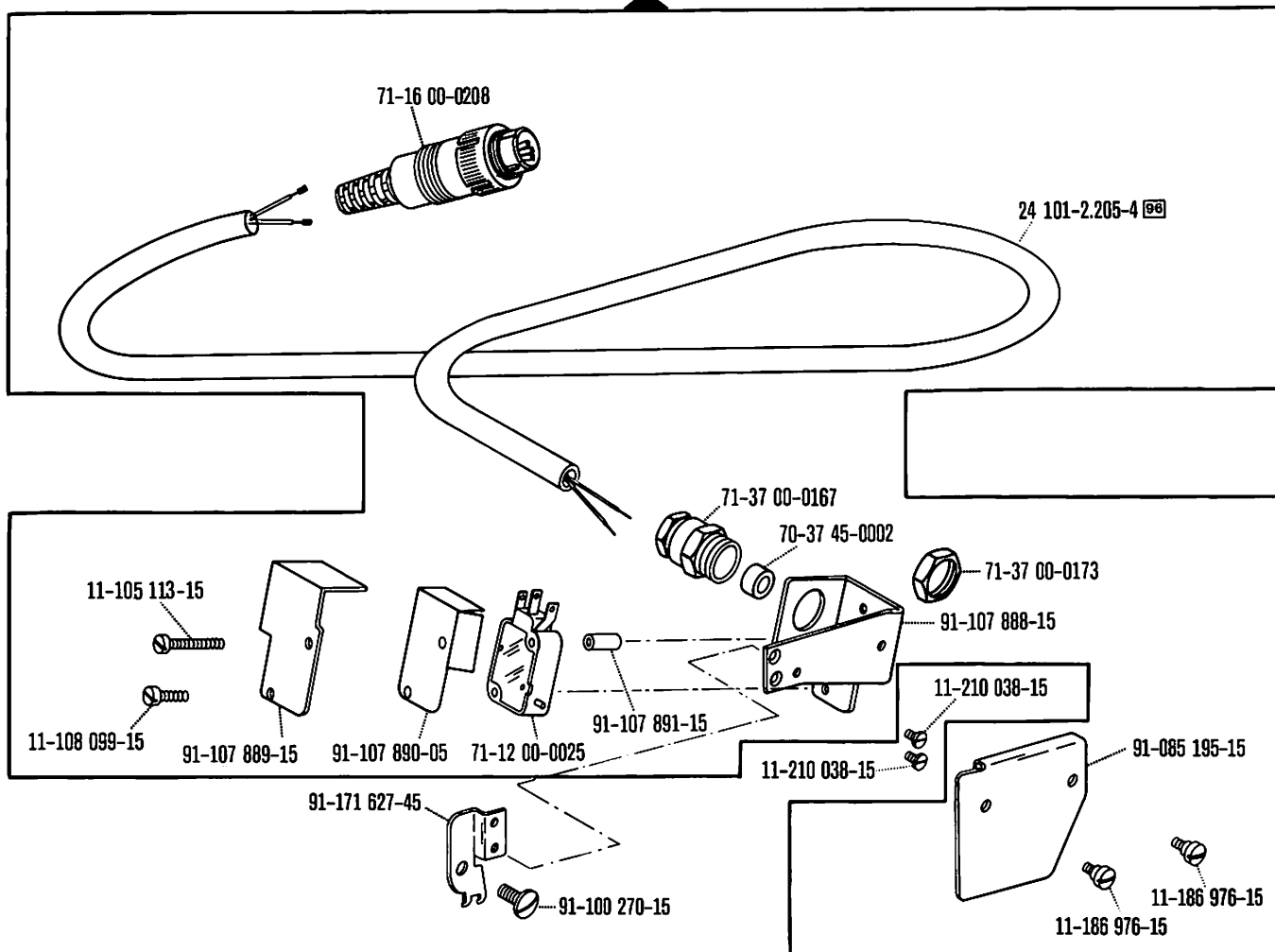

71-37 00-0309

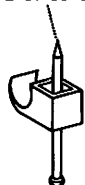

11-108 174-15

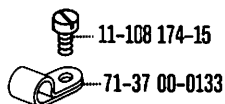

71-37 00-0133



91-099 811-05

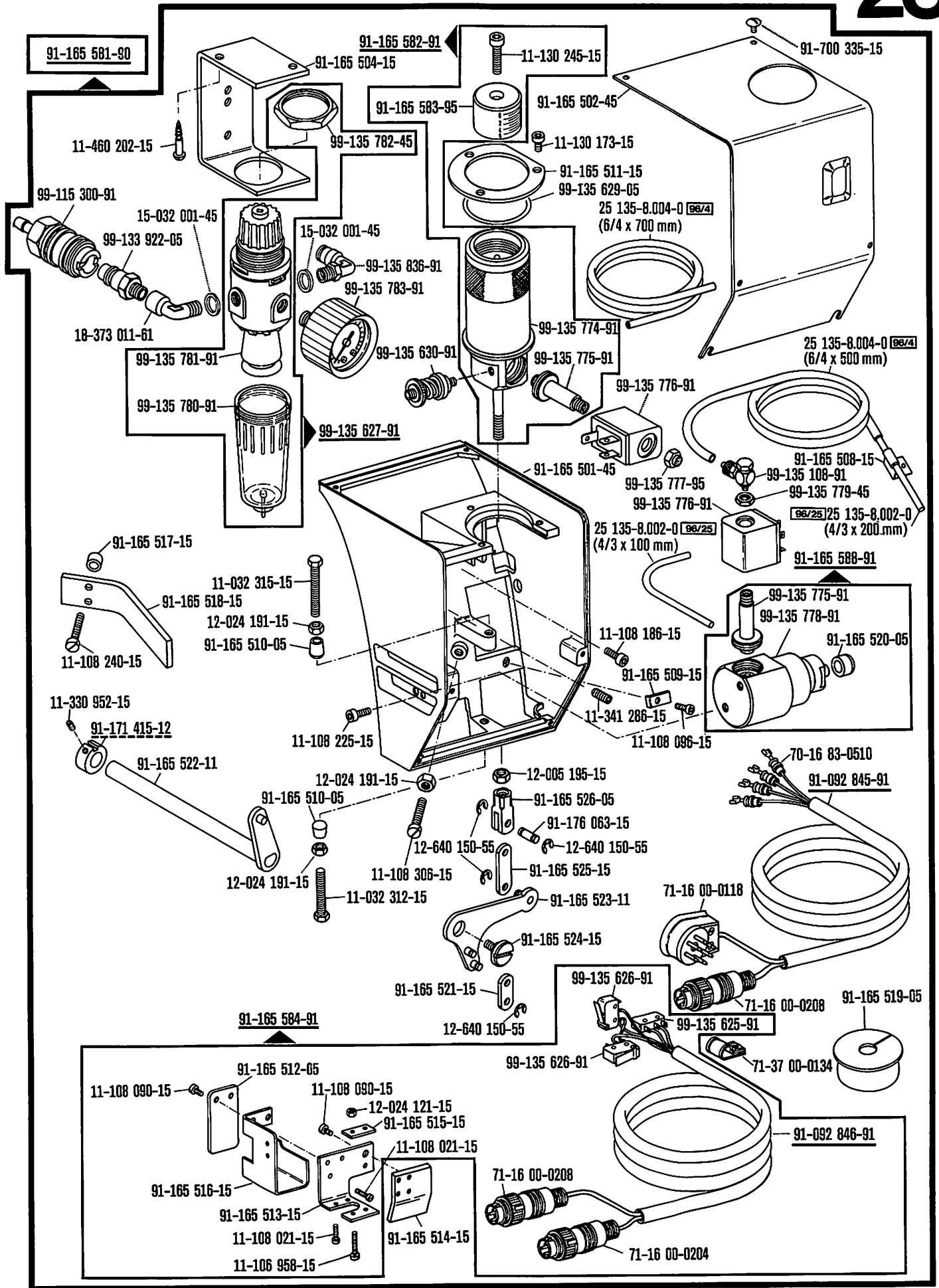

91-092 210-91 

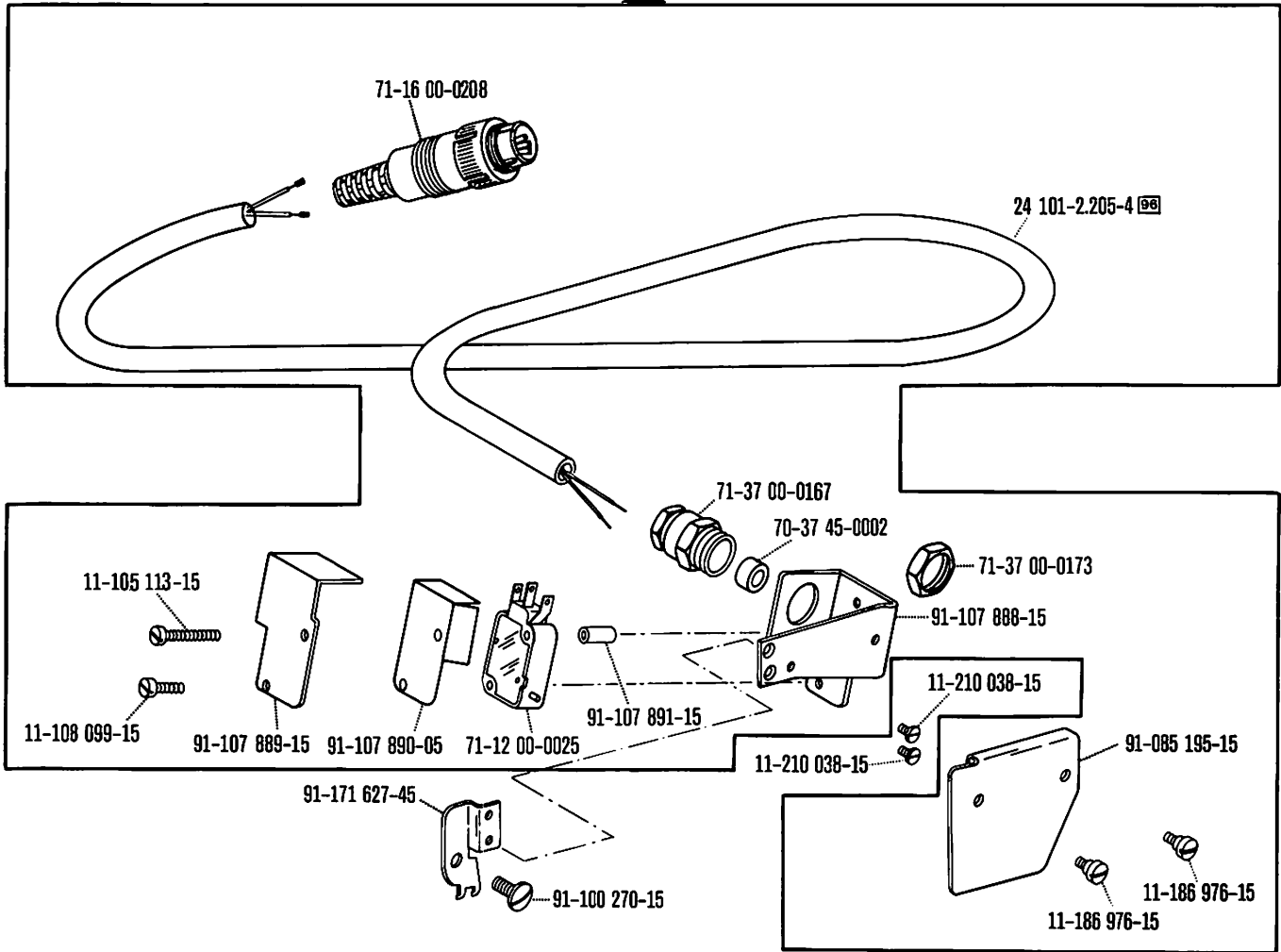

71-37 00-0309

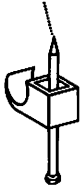

11-108 174-15



71-37 00-0133



91-099 811-05

Stichverdichtungs-Einrichtung
Stitch condensation mechanism
Rétrécisseur de points
Condensador de puntadas

-910/04*)-917/05
-917/05

zur / pour
 for / para **Pfaff 5483**

Wartungseinheit -925/02 erforderlich
 Conditioning unit -925/02 required
 Conditionneur d'air comprimé -925/02 nécessaire
 Requiere grupo acondicionador del
 aire comprimido -925/02

9.85

26

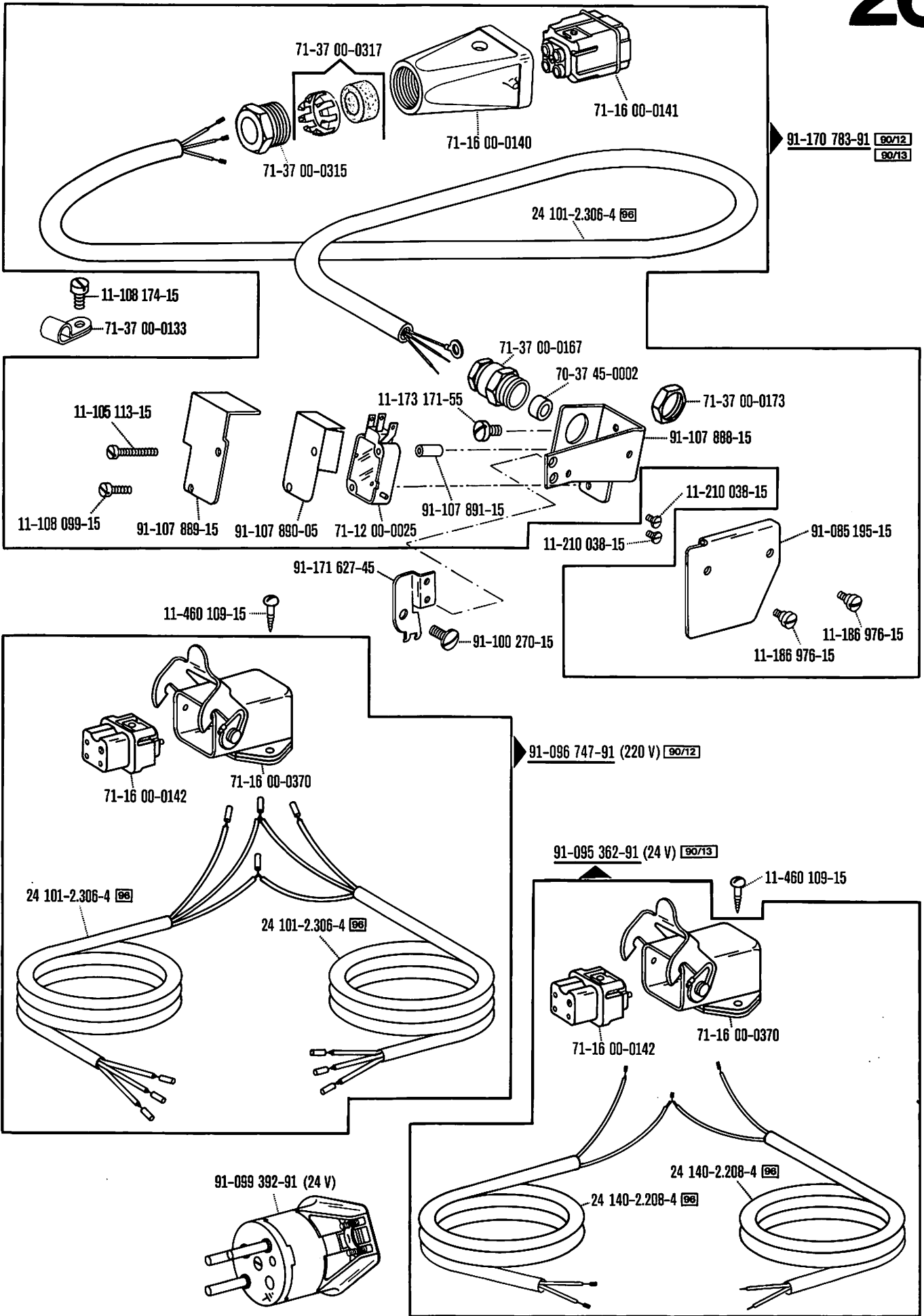

00-000 000-00 00-000 000-00 00-000 000-00 siehe Erläuterungen Register O
 see explanations on section O
 voir légende registre O
 ver explicaciones del registro O

*) Presserfuß-Automatik
 Automatic presser foot lifter
 Relève-pied automatique
 Alzaprensateelas

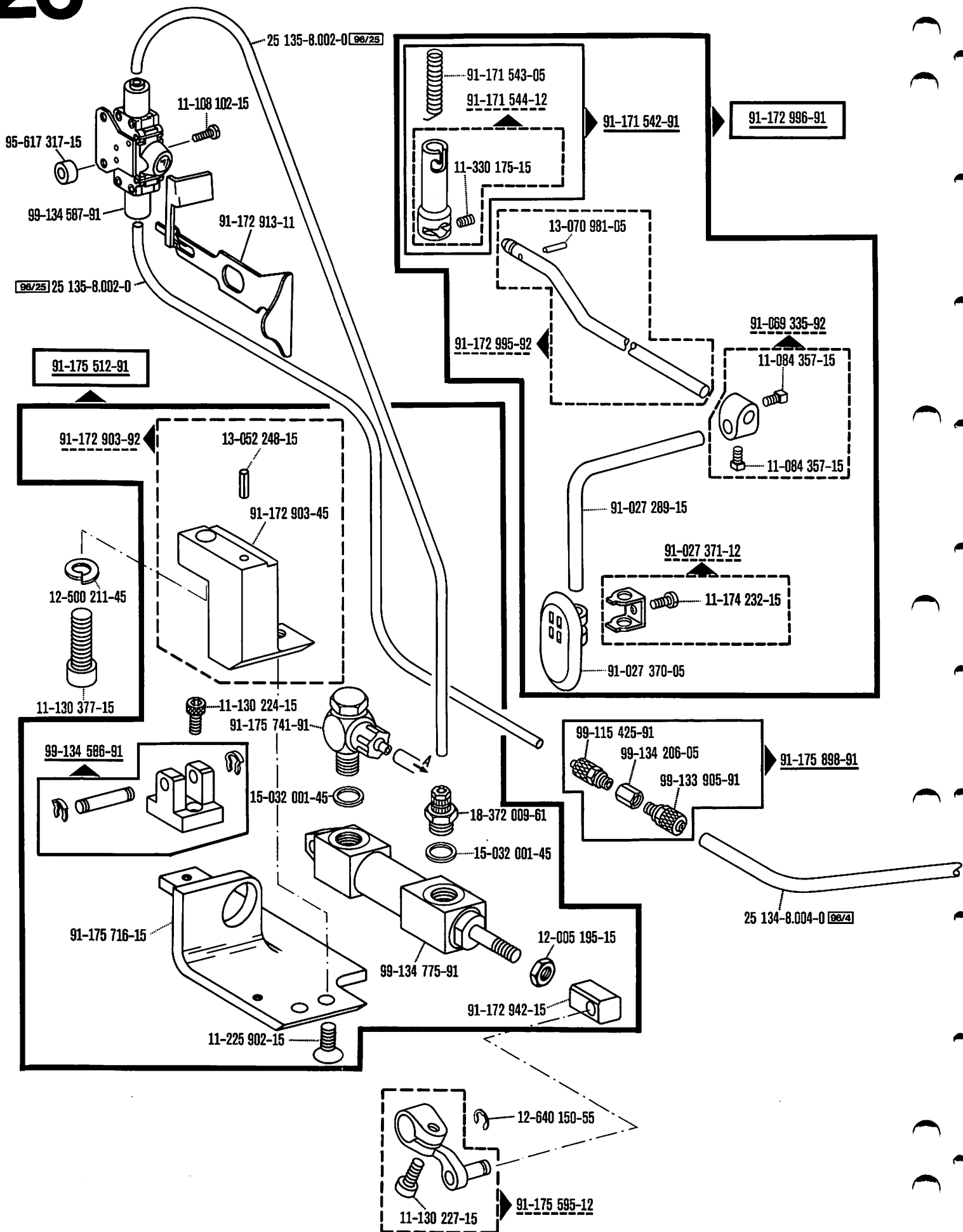

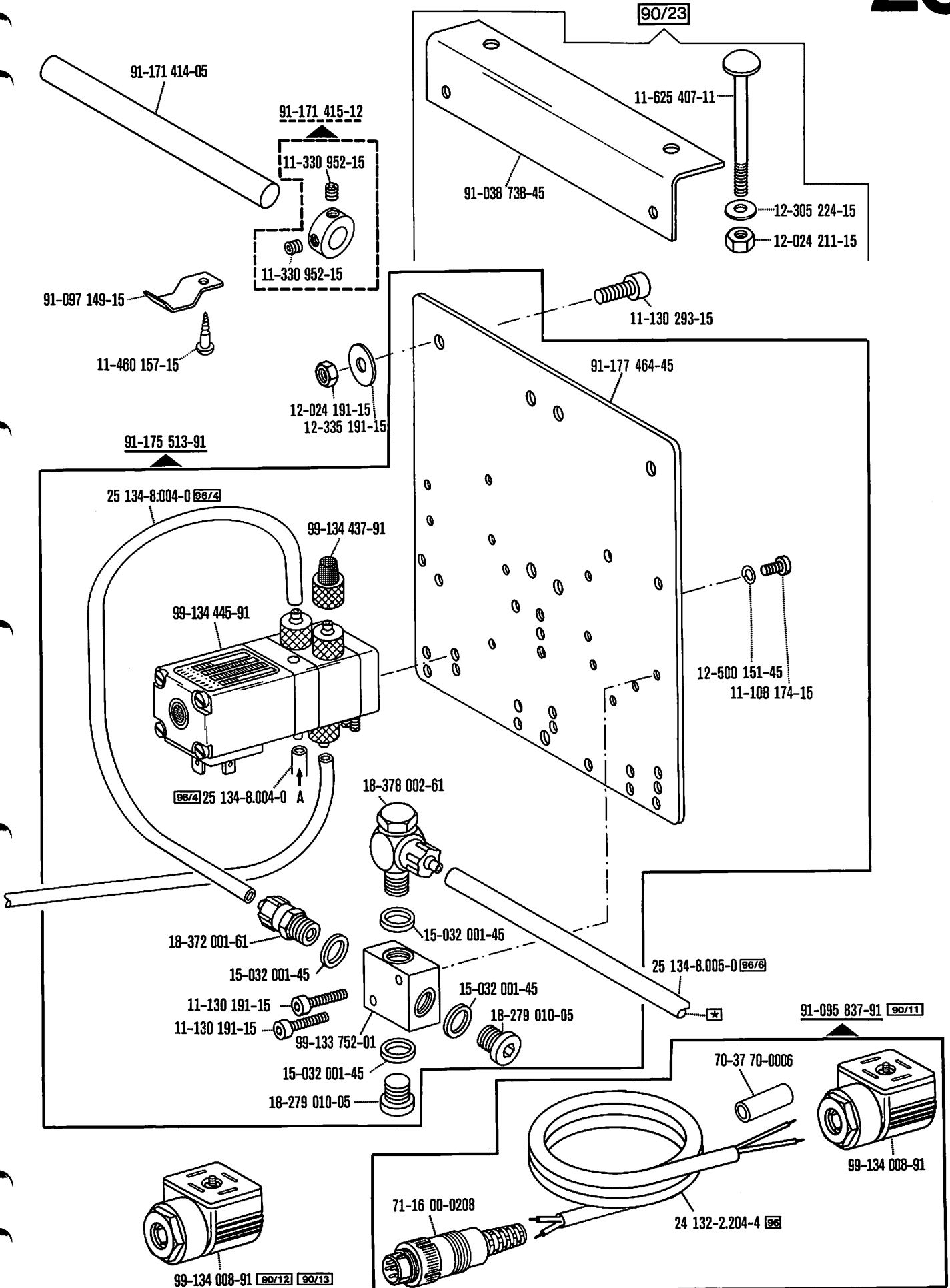

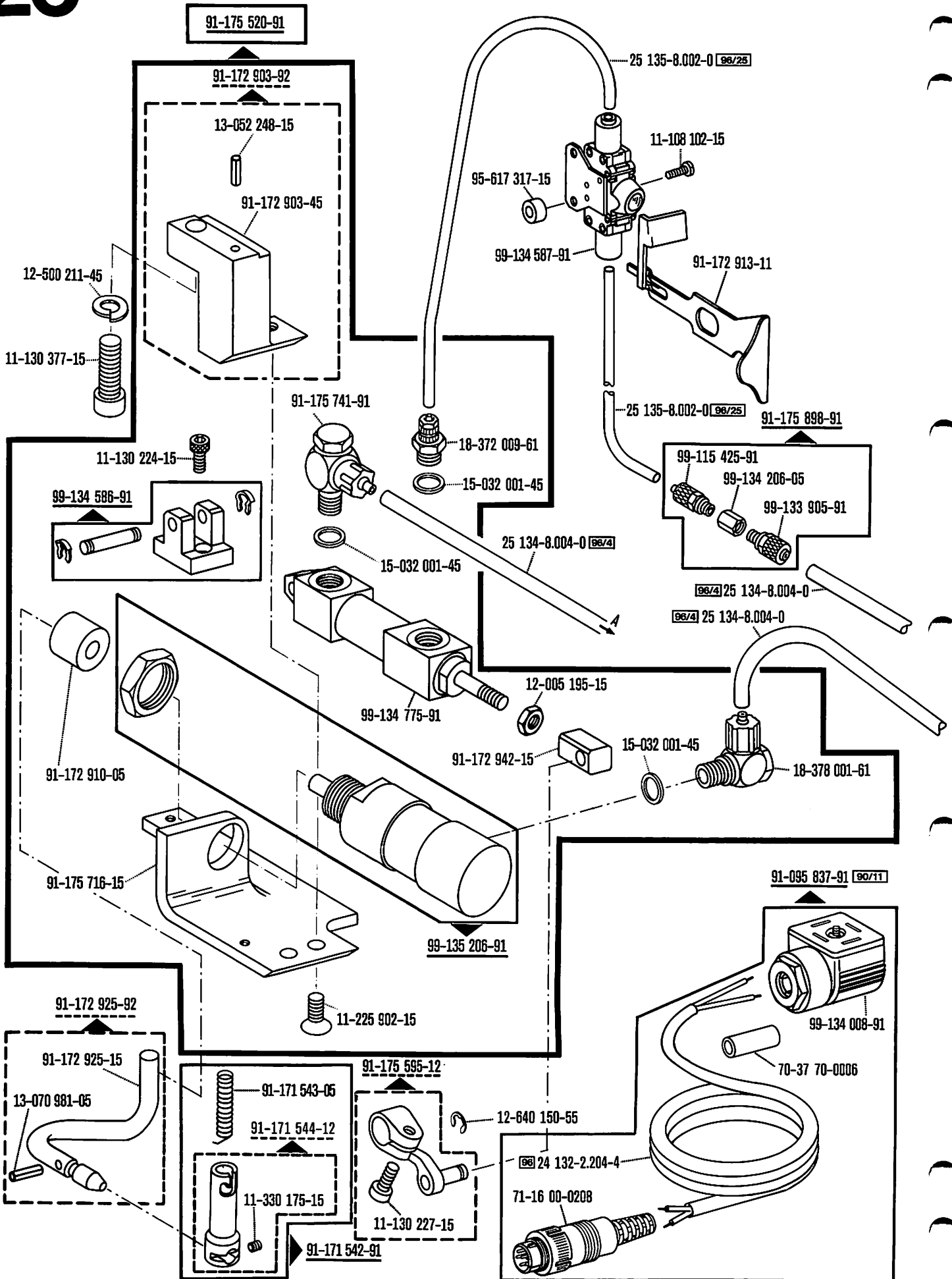

*) Presserfuß-Automatik
 Automatic presser foot lifter
 Relève-pied automatique
 Alzapuntetas

Stichverdichtungs-Einrichtung
Stitch condensation mechanism
Rétrécisseur de points
Condensador de puntadas

-910/04*)-917/05 zur · pour for · para **Pfaff 5483**

Wartungseinheit -925/02 erforderlich
 Conditioning unit -925/02 required
 Conditionneur d'air comprimé -925/02 nécessaire
 Requiere grupo acondicionador del aire comprimido -925/02

9.85

26

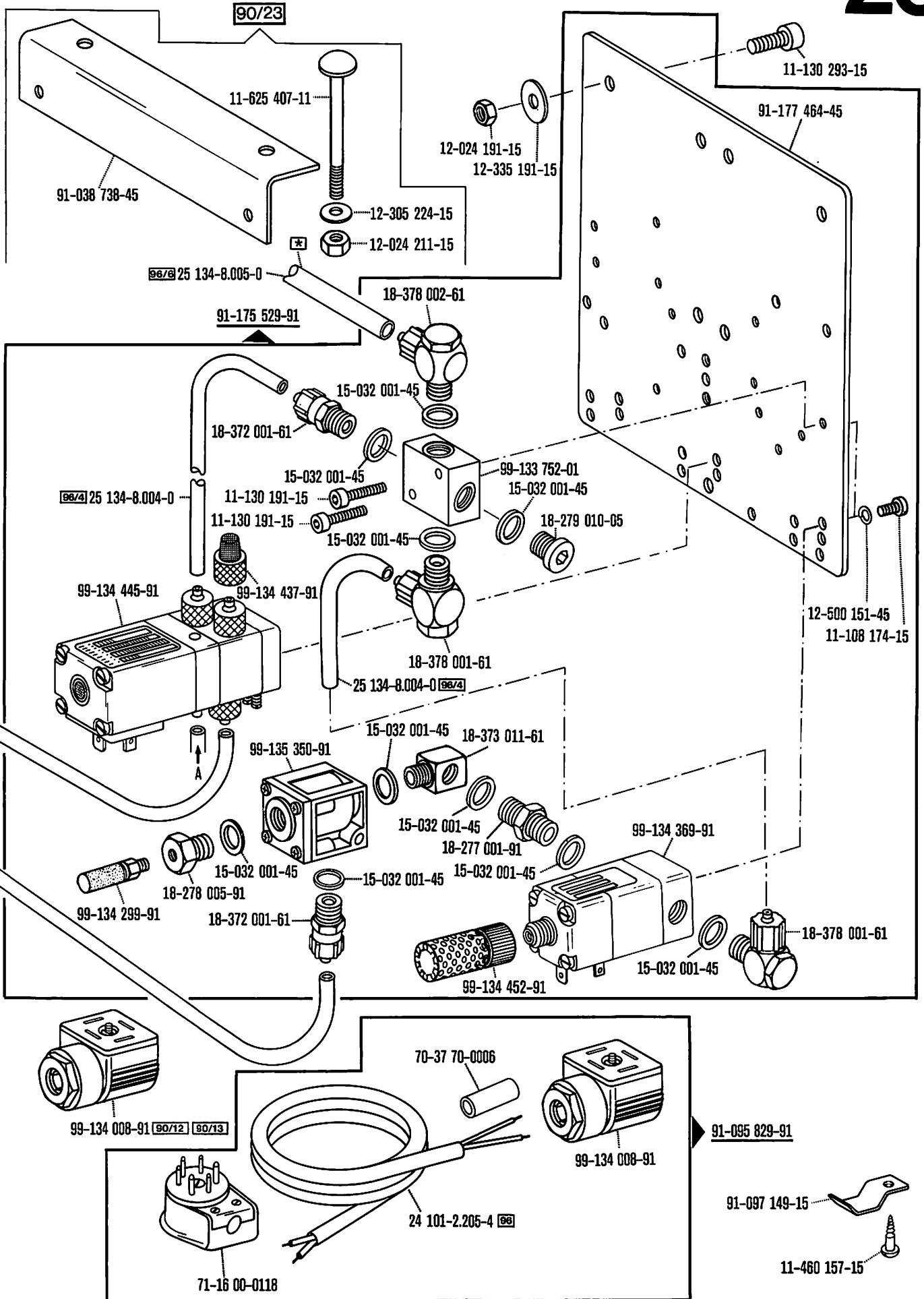

00-000 000-00 00-000 000-00 00-000 000-00 siehe Erläuterungen Register O
 see explanations on section O
 voir légende registre O
 ver explicaciones del registro O

Zur Wartungseinheit
 For conditioning unit
 Pour la conditionneur d'air comprimé
 Para las require grupo acondicionador del aire

Presserfuß-Automatik
 Automatic presser foot lifter
 Relève-pied automatique
 Alzaprensataelas

Stichverdichtungs-Einrichtung
Stitch condensation mechanism
Rétrécisseur de points
Condensador de puntadas

-917/15*)
-917/35*)

zur - pour
 for - para **Pfaff 5483**

Wartungseinheit -925/02 erforderlich
 Conditioning unit -925/02 required
 Conditionneur d'air comprimé -925/02 nécessaire
 Requiere grupo acondicionador del
 aire comprimido -925/02

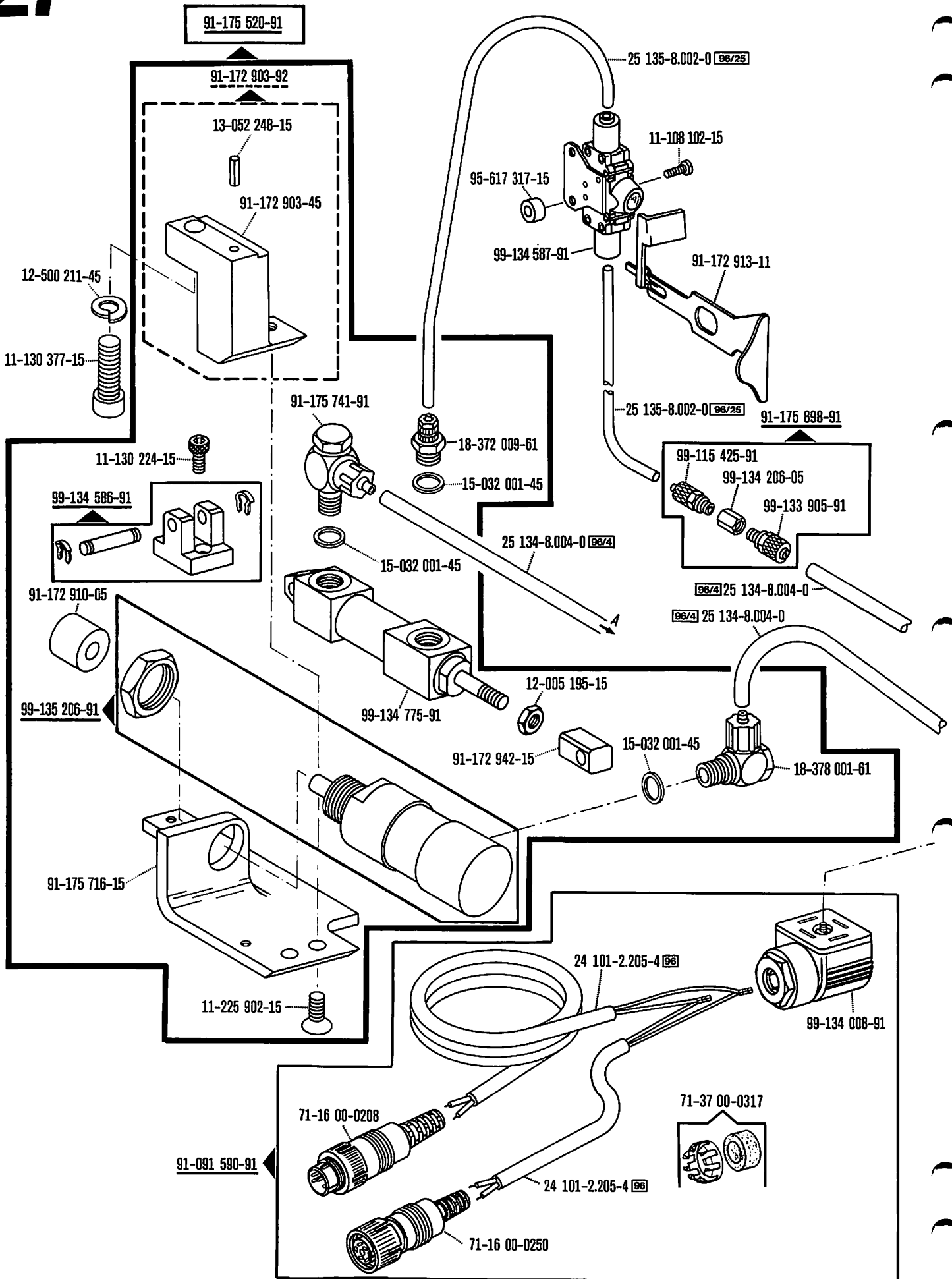

*) Beinhaltet Presserfußautomatik -910/04
 With automatic presser foot lifter -910/04
 Retève-pied compris. -910/04
 Alzaprensateñas automático -910/04

00-000 000-00 00-000 000-00 00-000 000-00

☐ siehe Erläuterungen Register O
 see explanations on section O
 voir légende registre O
 ver explicaciones del registro O

Stichverdichtungs-Einrichtung
Stitch condensation mechanism
Rétrécisseur de points
Condensador de puntadas

-917/15*) zur · pour
-917/35*) for · para **Pfaff 5483**

Wartungseinheit -925/02 erforderlich
 Conditioning unit -925/02 required
 Conditionneur d'air comprimé -925/02 nécessaire
 Requiere grupo acondicionador del
 aire comprimido -925/02

9.85

27

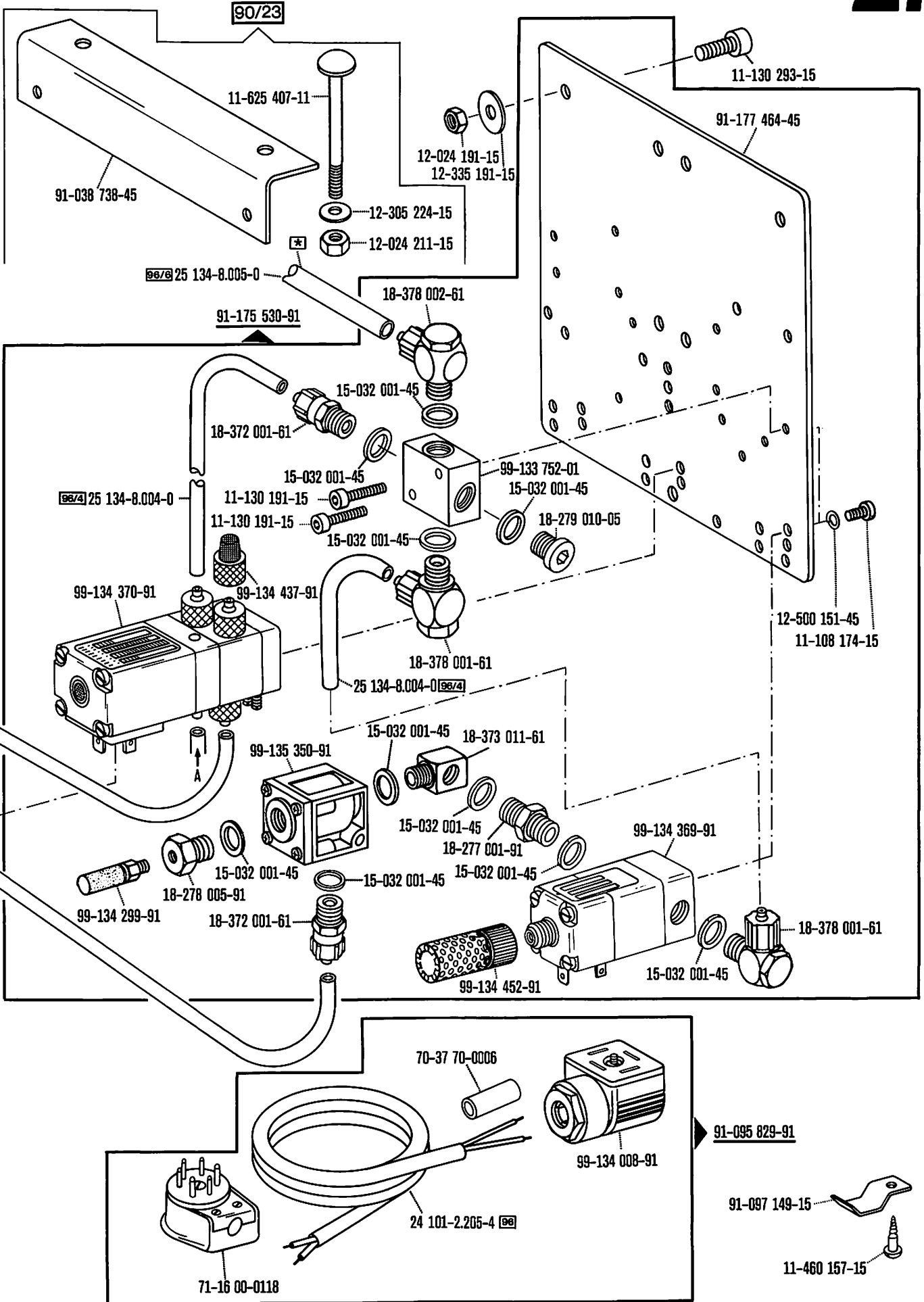

00-000 000-00 00-000 000-00 00-000 000-00

☐ siehe Erläuterungen Register O
 see explanations on section O
 voir légende registre O
 ver explicaciones del registro O

*) Beinhaltet Presserfußautomatik -910/04
 With automatic presser foot lifter -910/04
 Relève-pied compris. -910/04
 Alzaprensataelas automático -910/04

☐ Zur Wartungseinheit
 For conditioning unit
 Pour la conditionneur d'air comprimé
 Para las require grupo acondicionador del aire

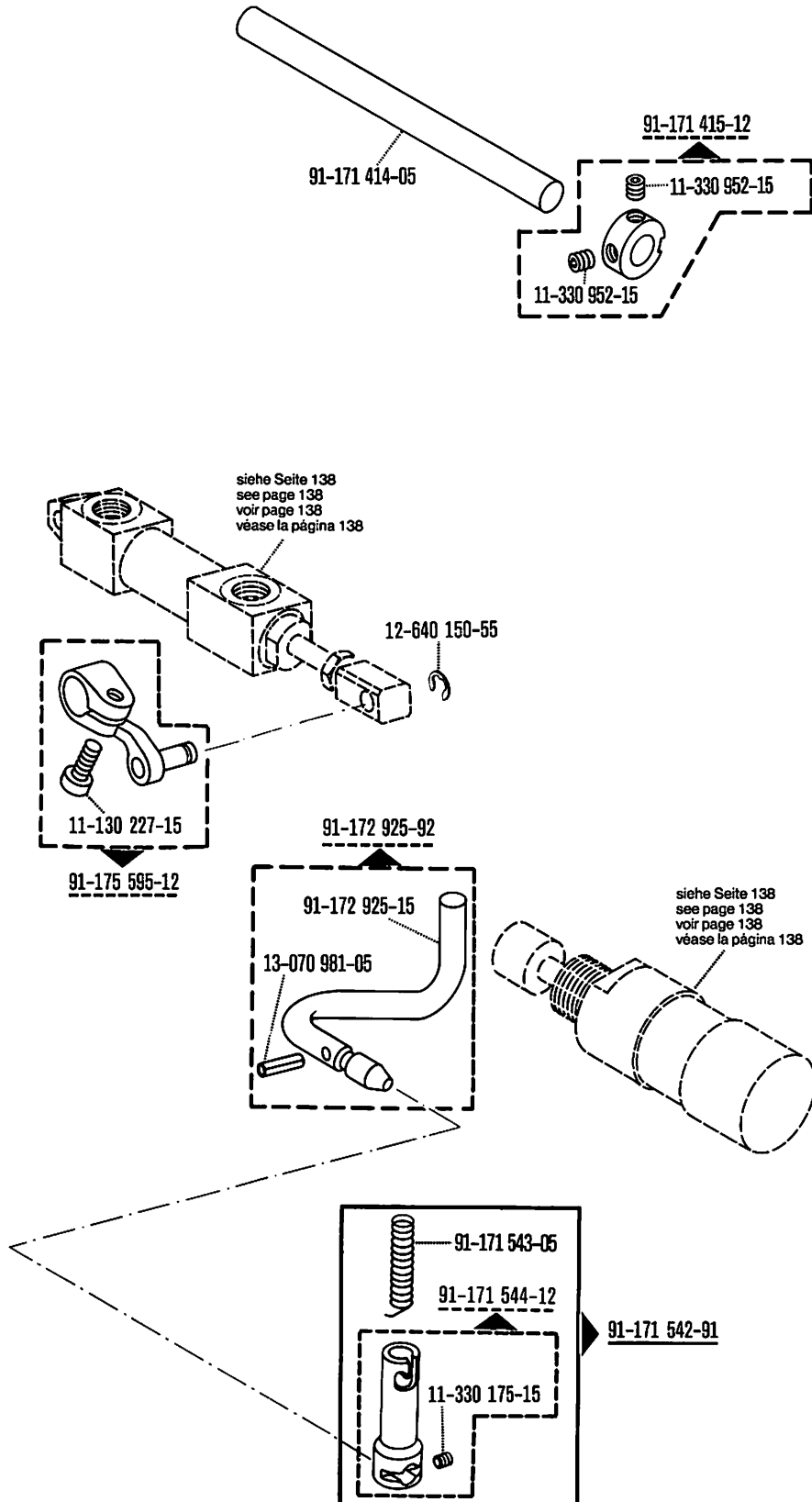

91-092 210-91

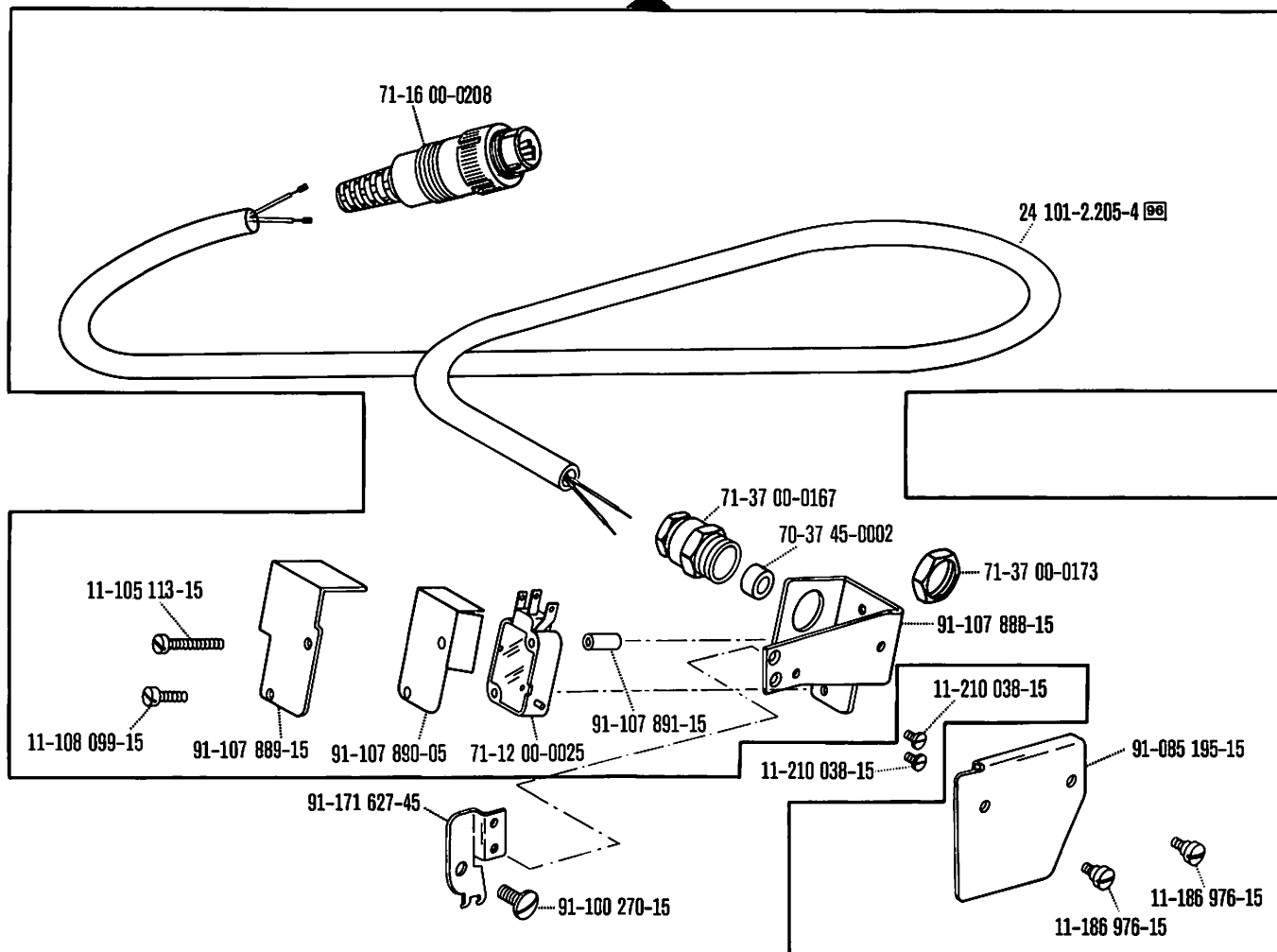

71-37 00-0309

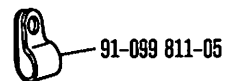
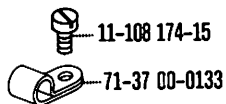
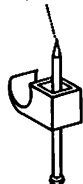

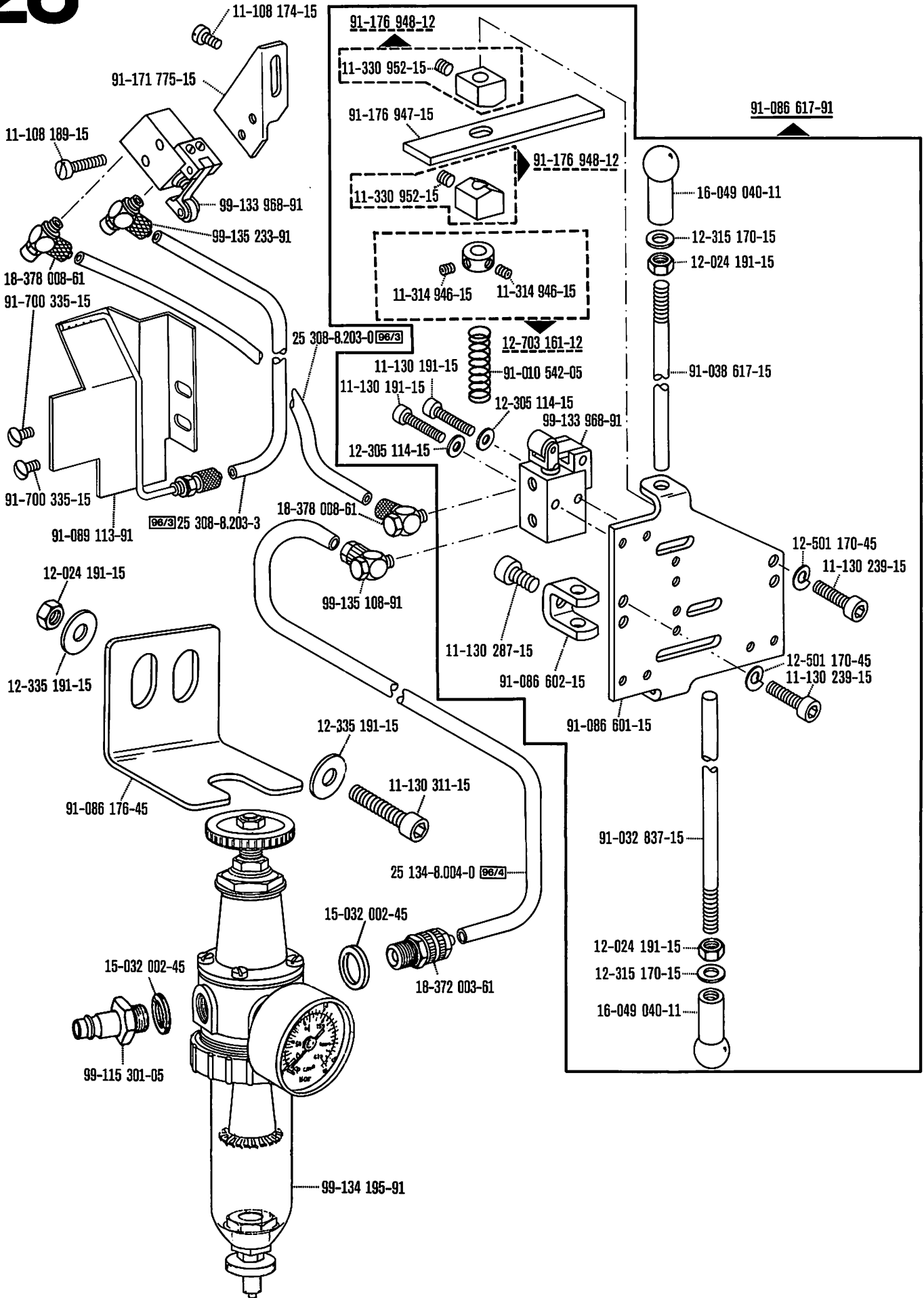

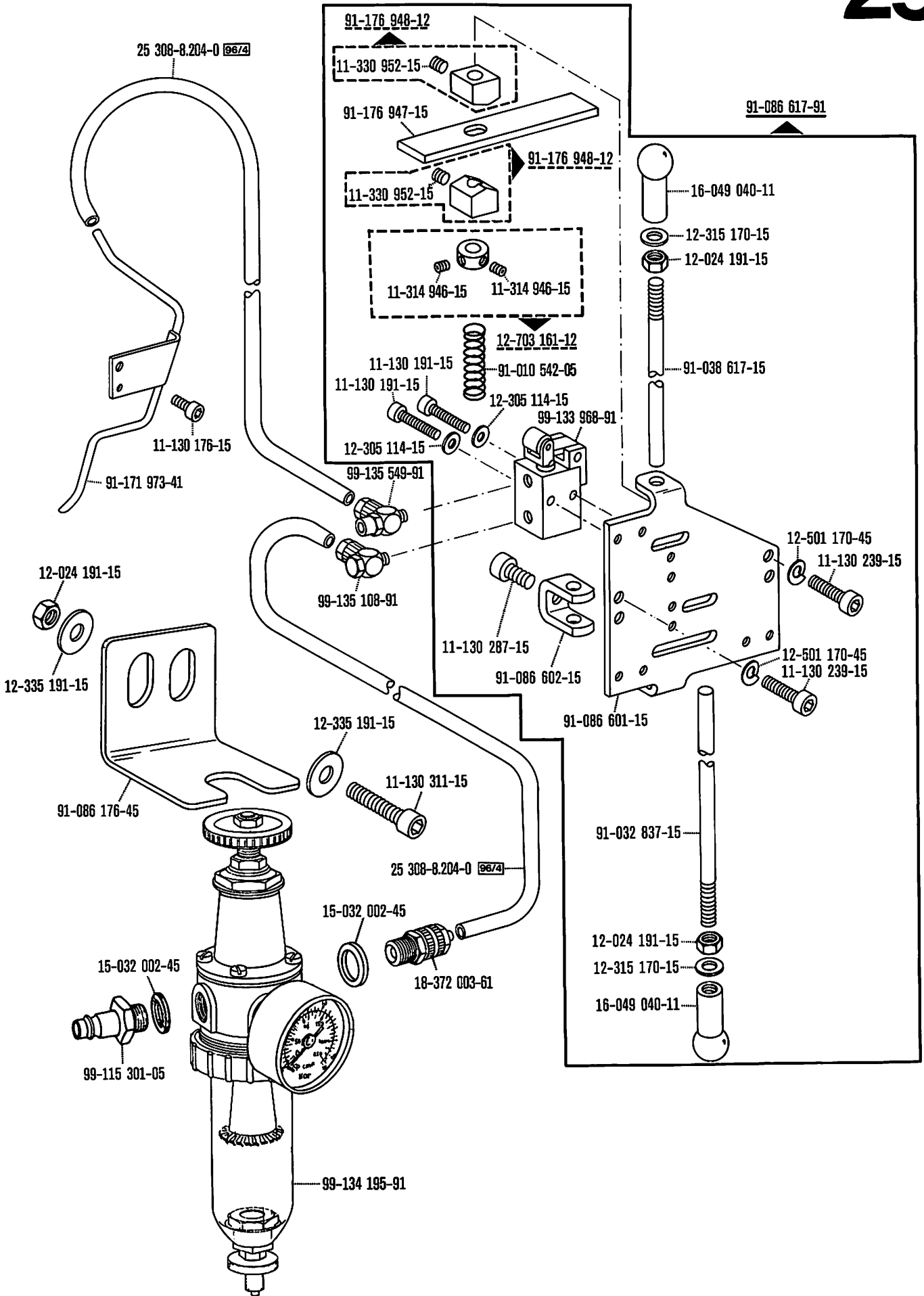

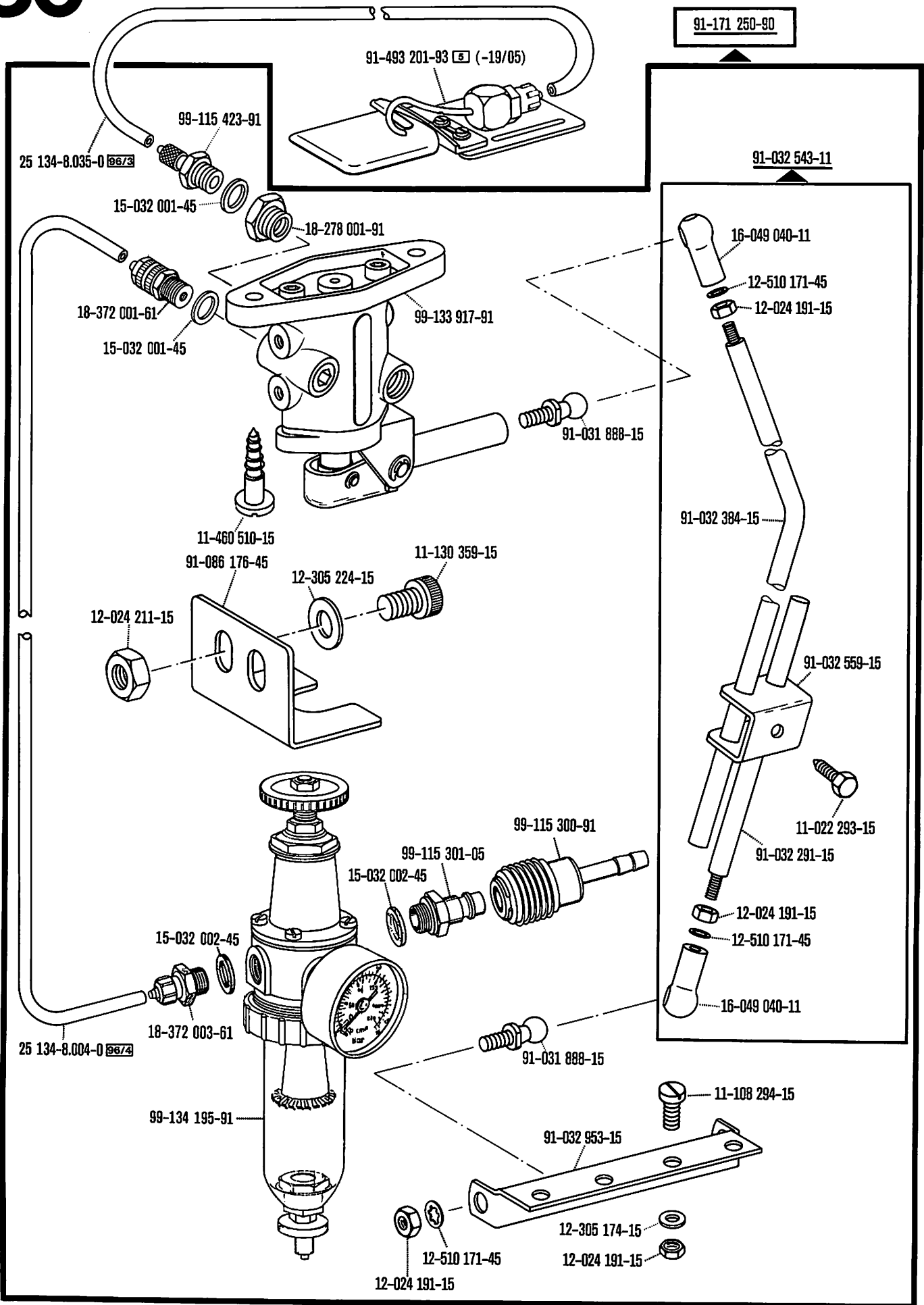

91-171 462-90 30/13

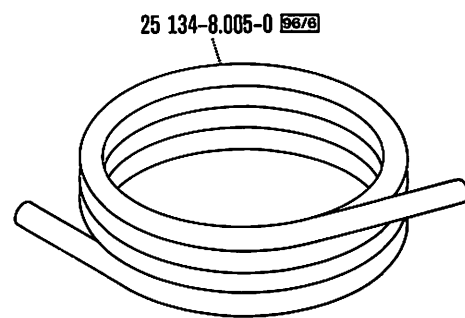
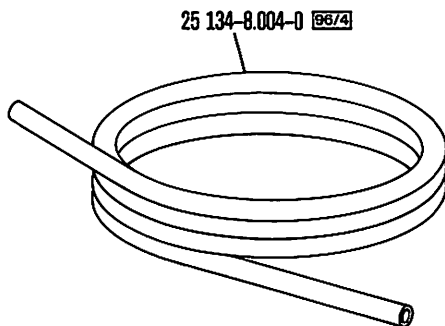
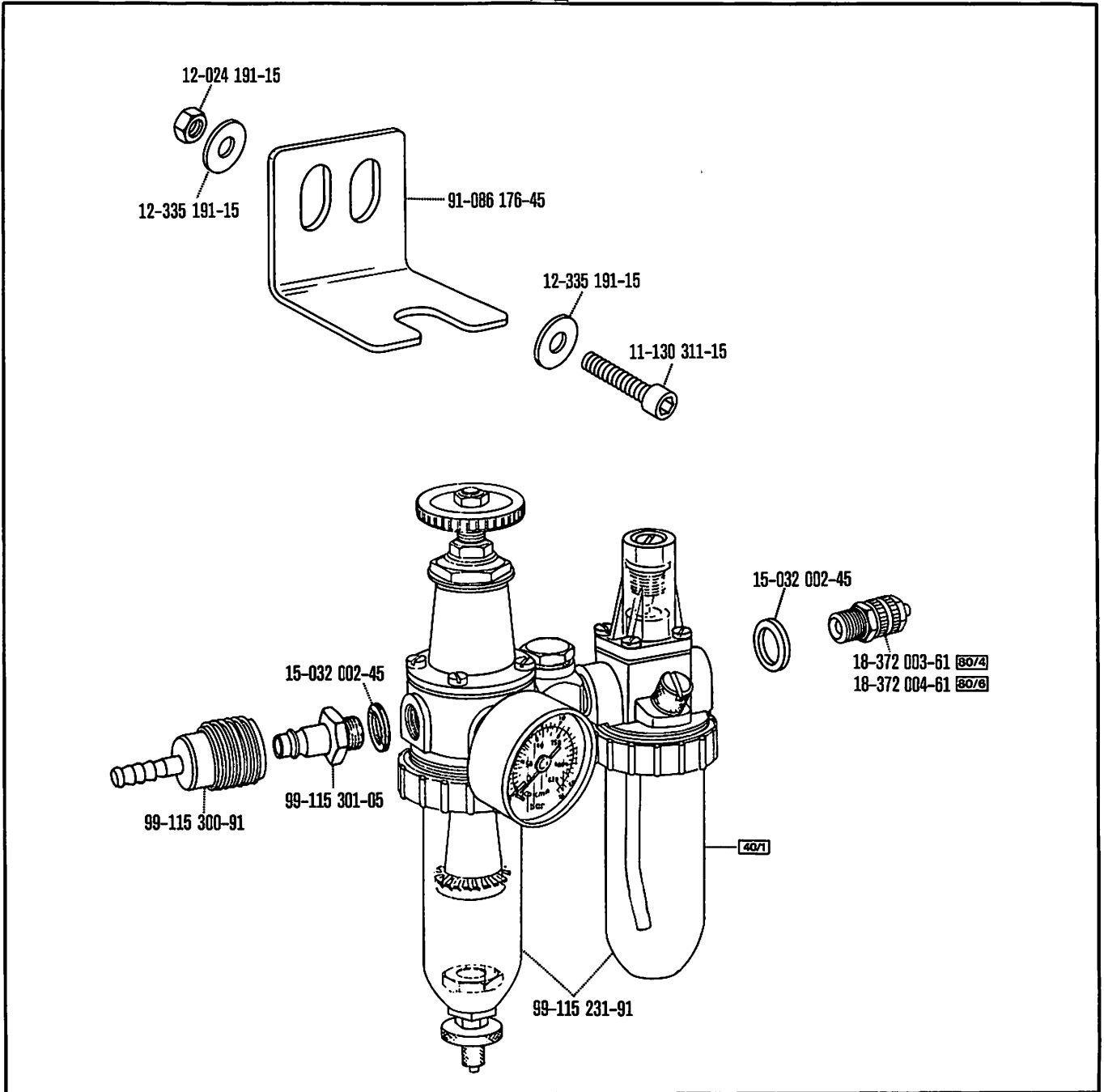

91-171 462-70/993

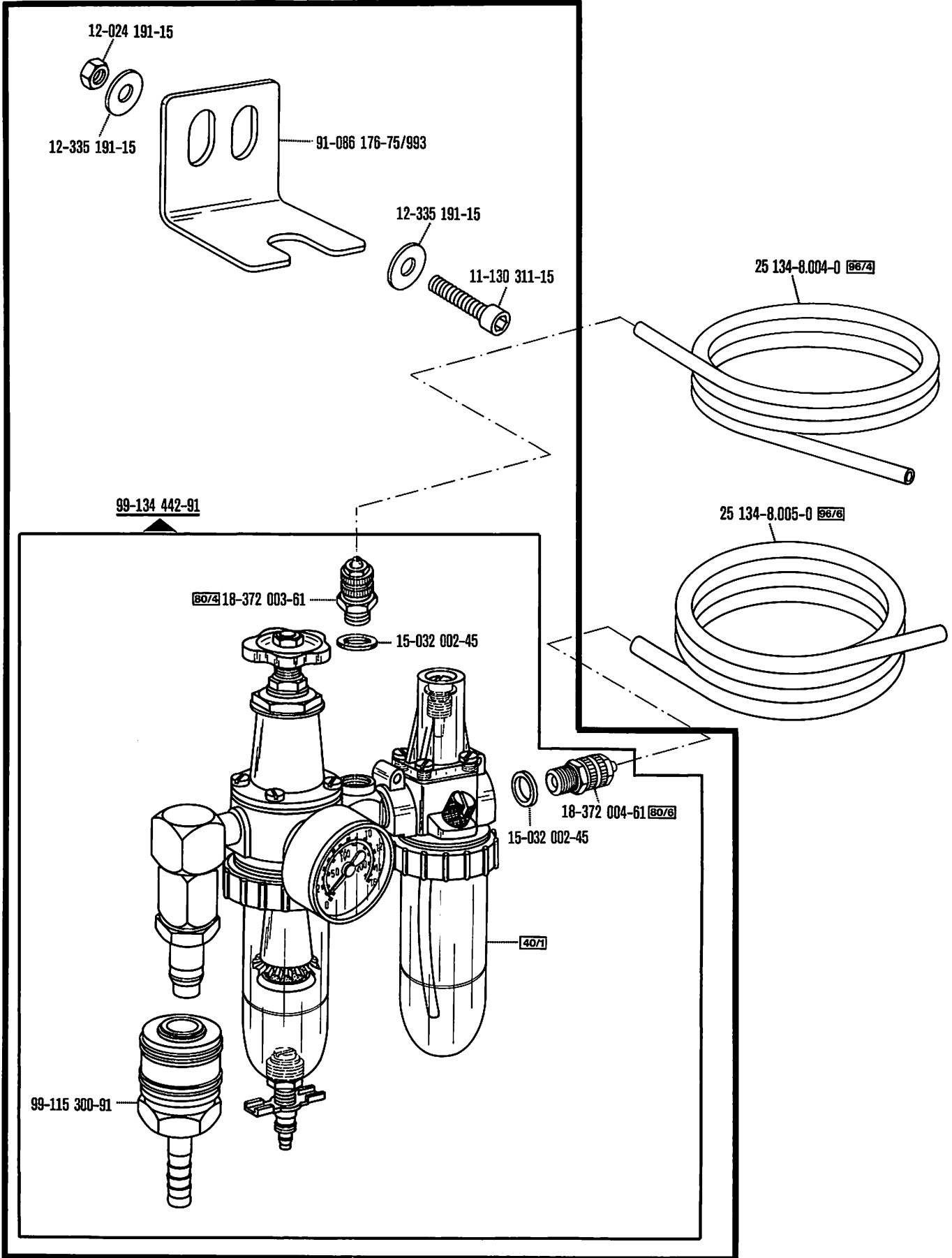

91-033 073-90

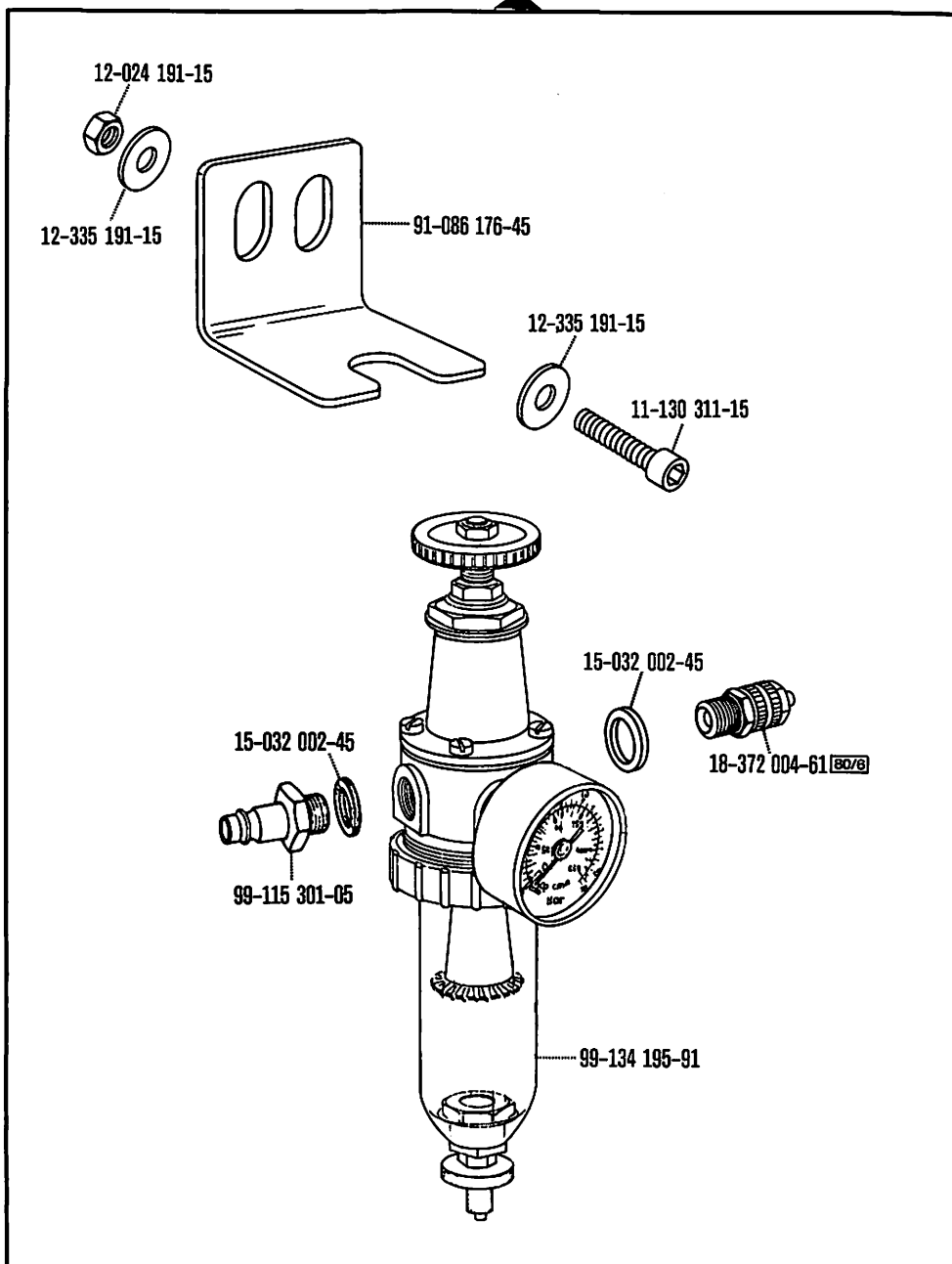

25 134-8.005-0 

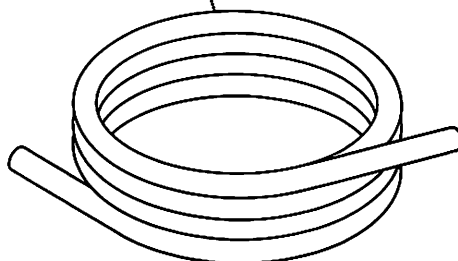

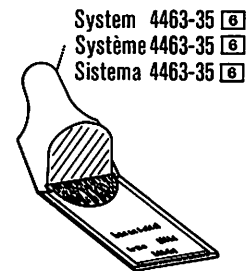
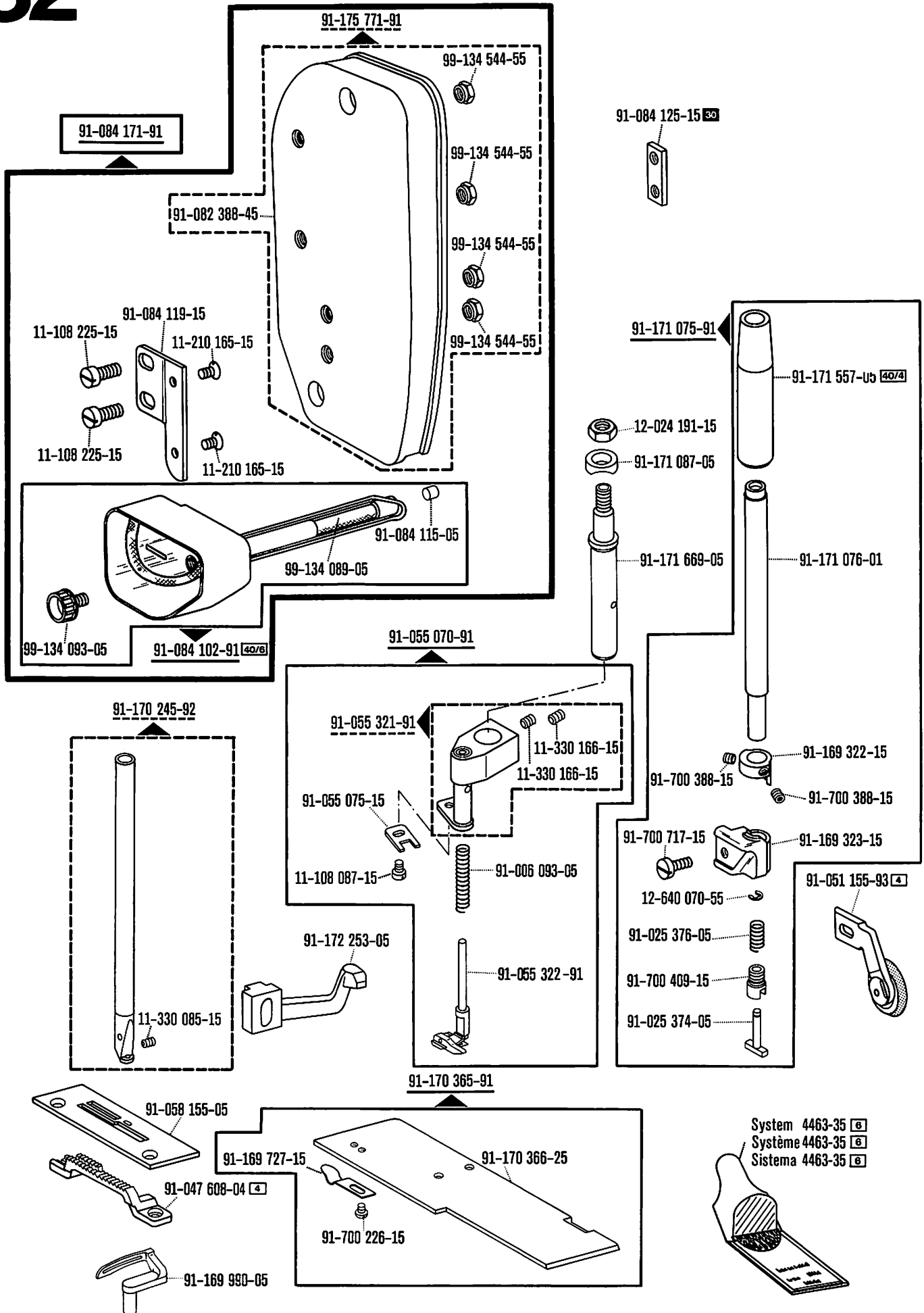

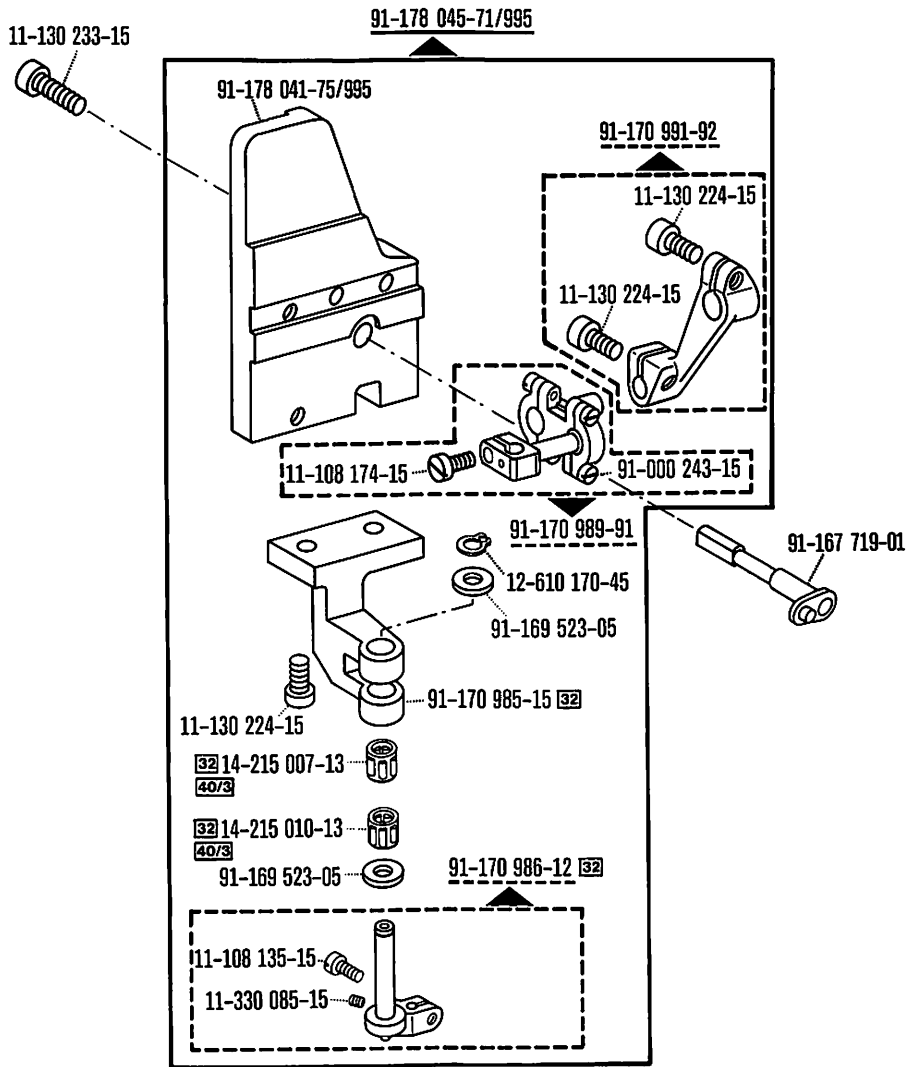

-818/55

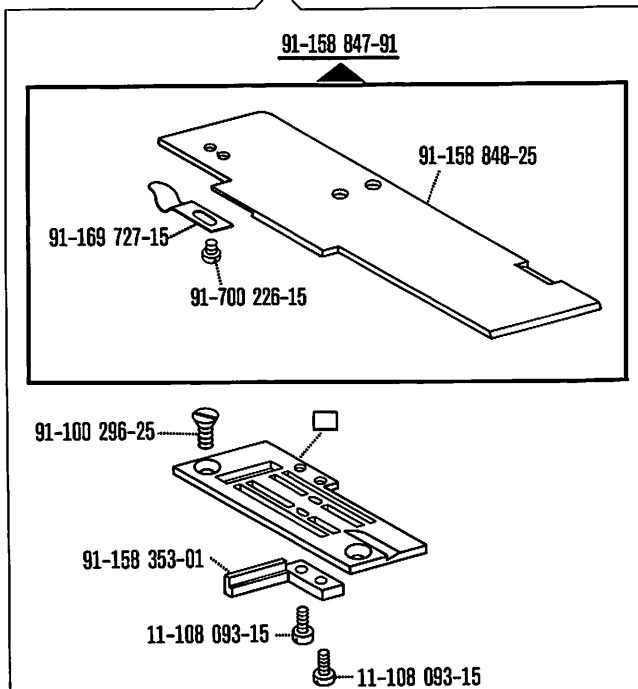

-818/56

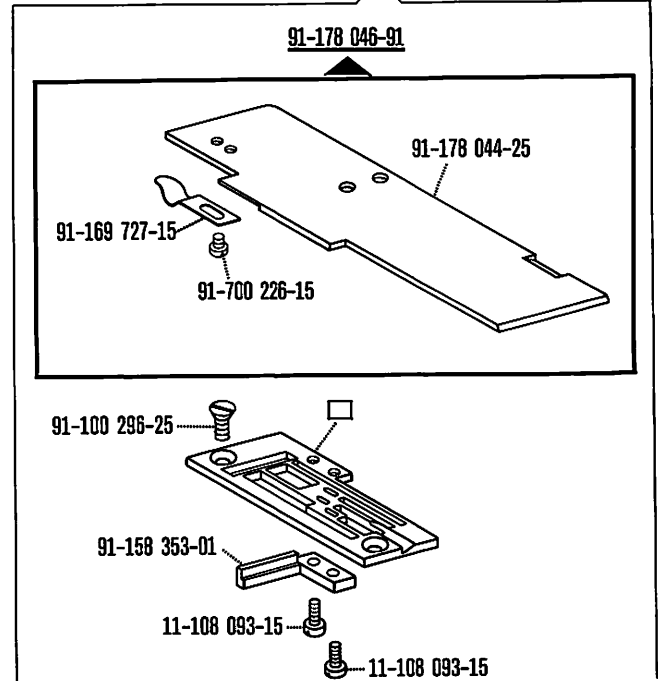

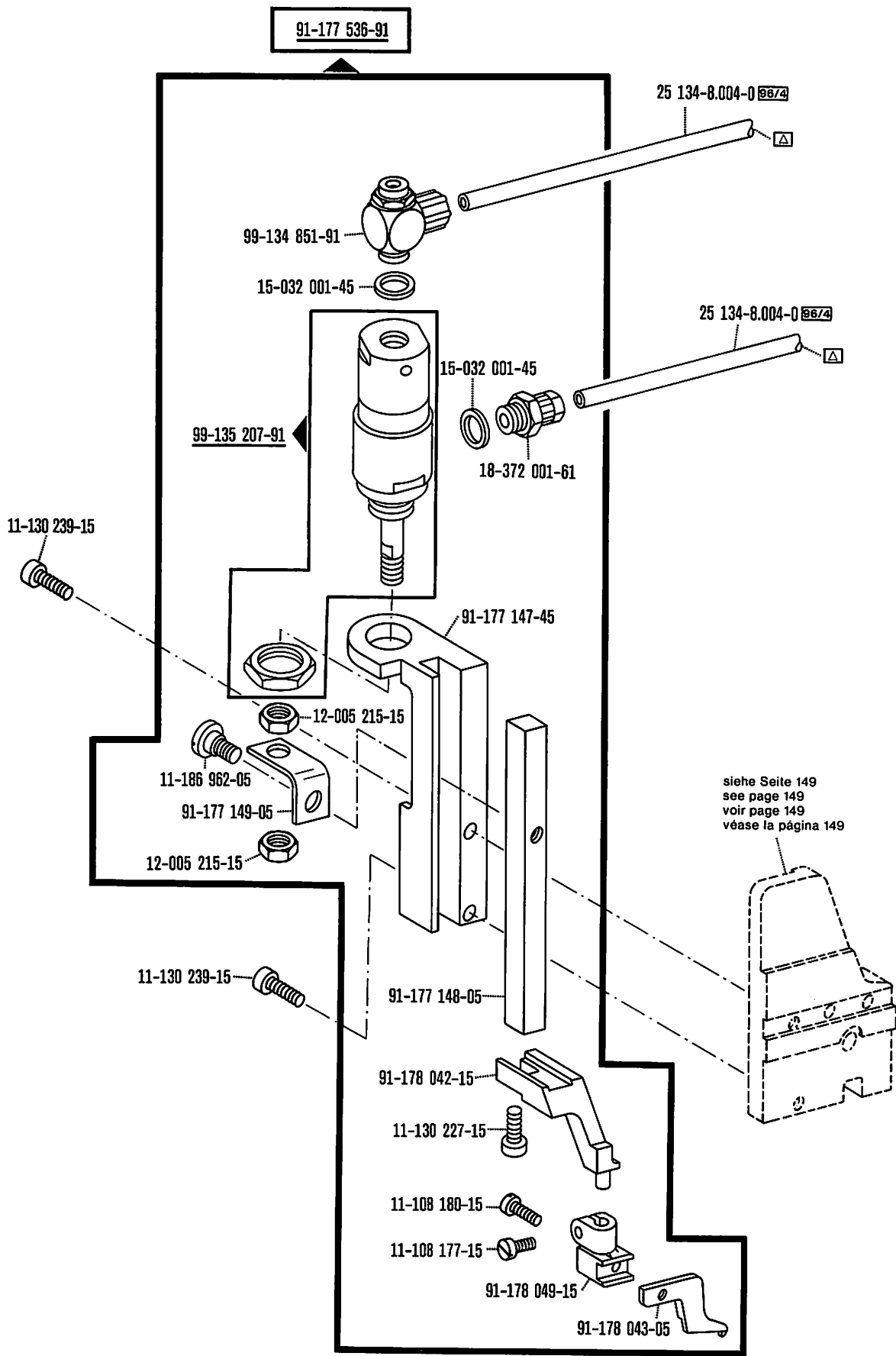

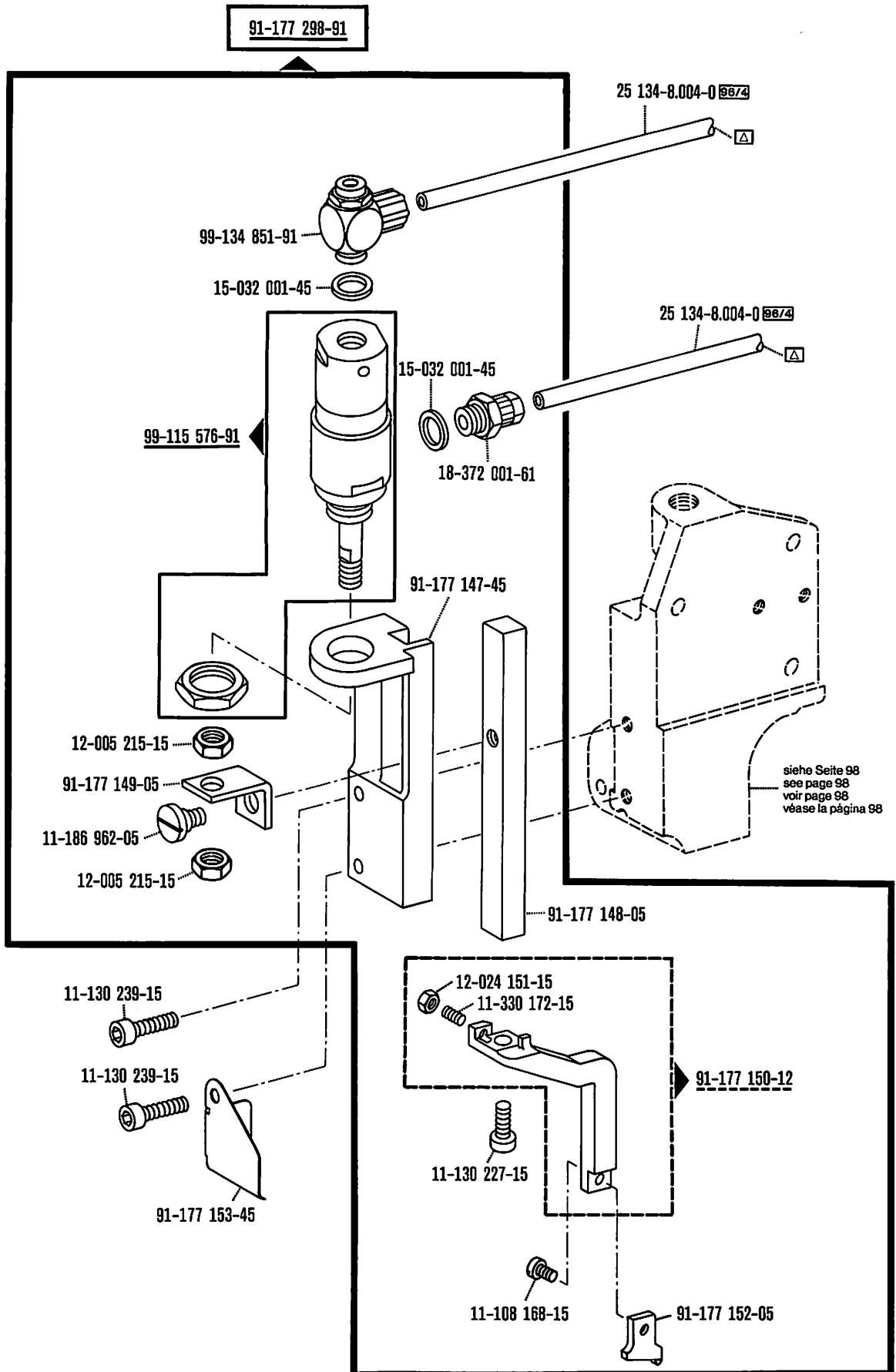

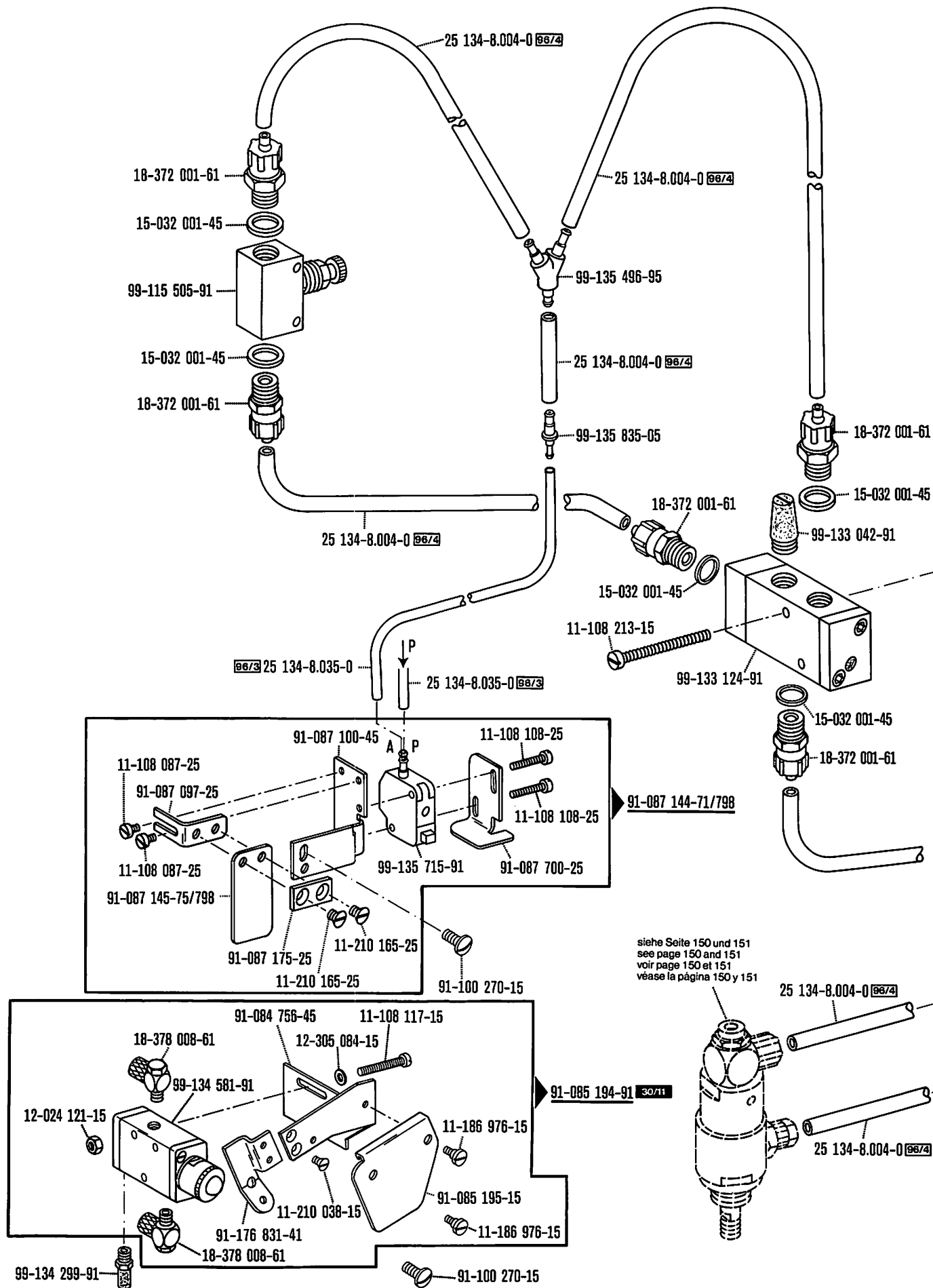

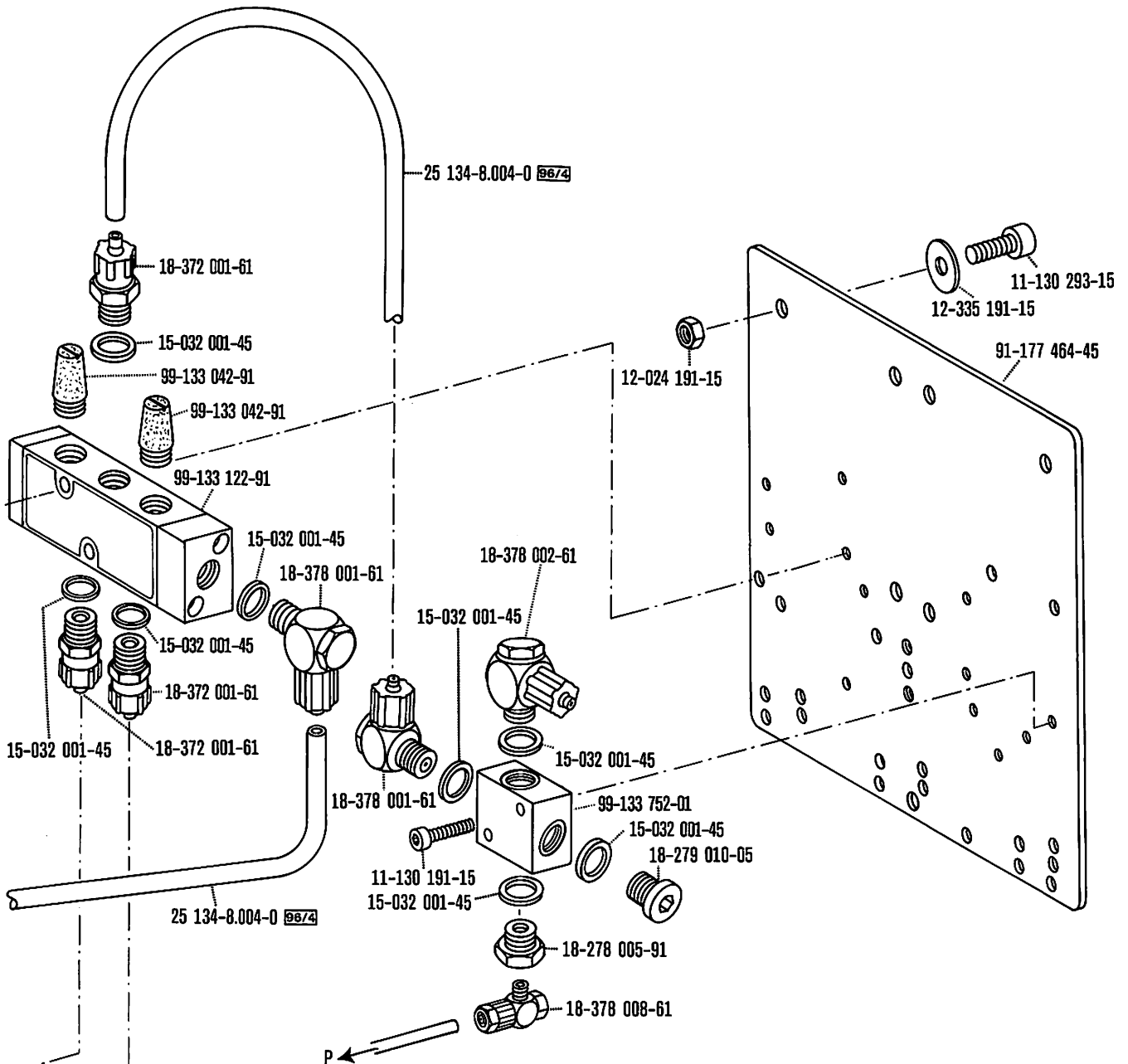

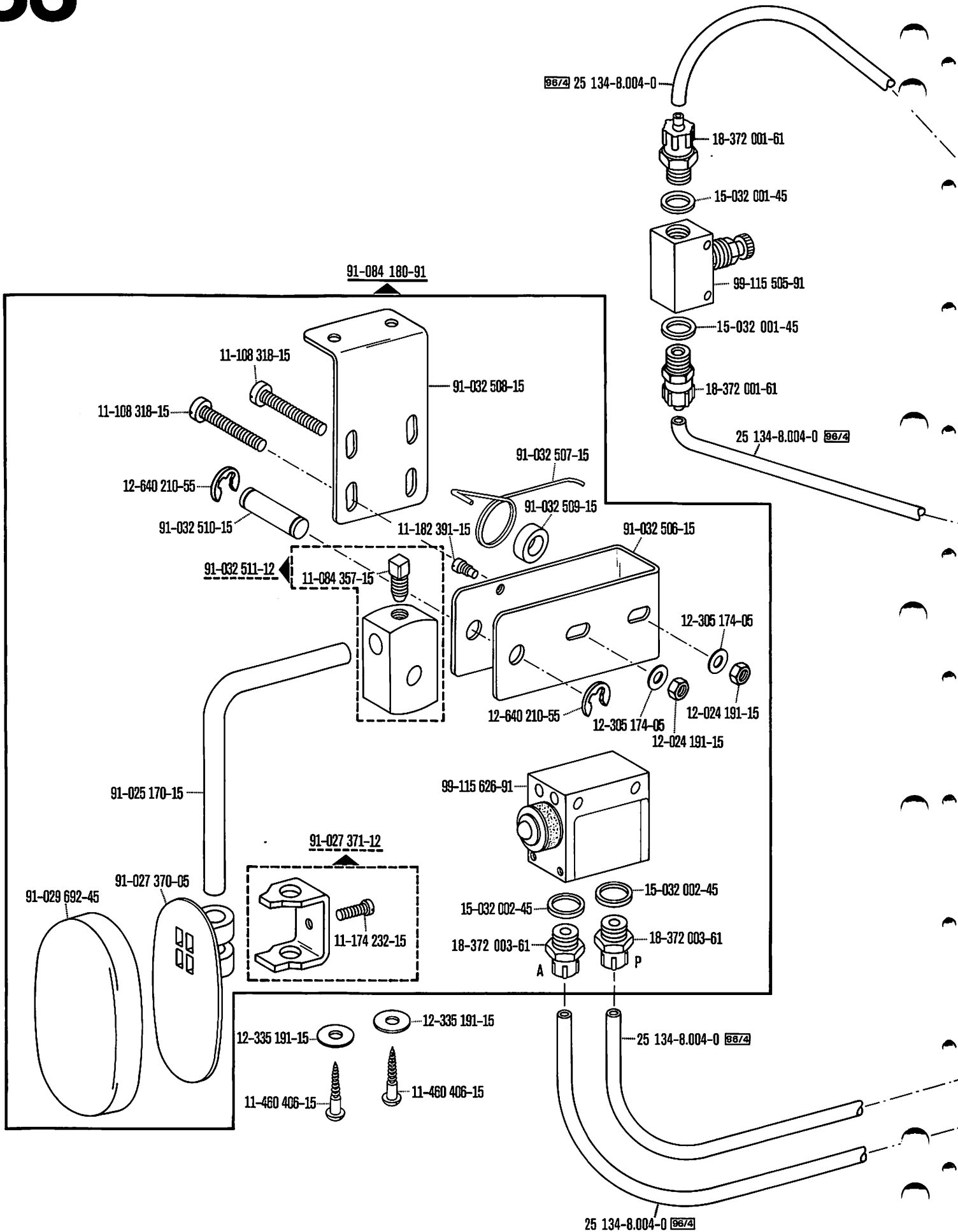

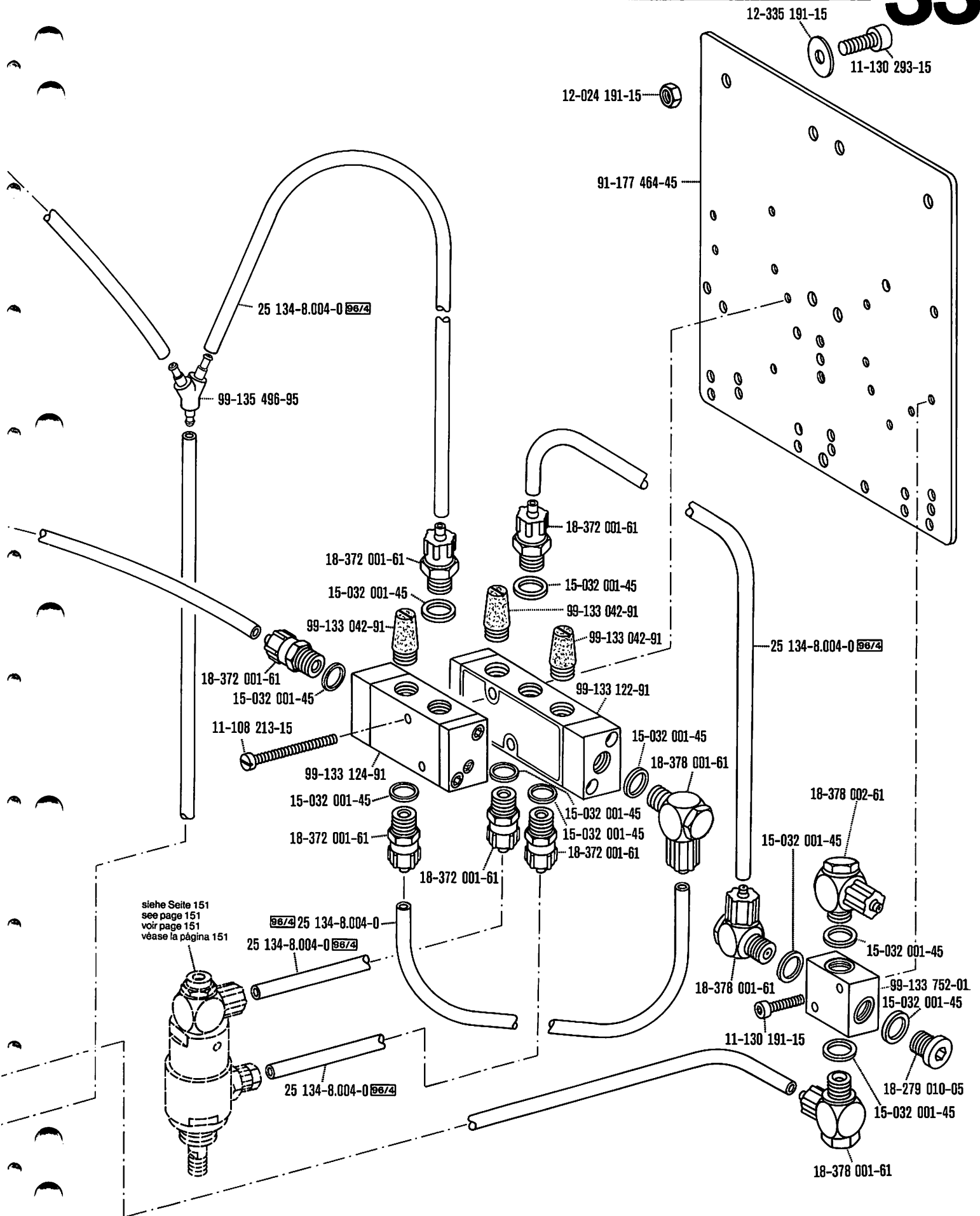

siehe Seite 151
 see page 151
 voir page 151
 véase la página 151

91-084 153-91 (-6/01; -6/02; -6/10)
 91-084 164-91 (-58/01; -57/01)

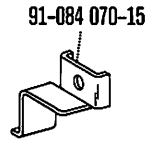
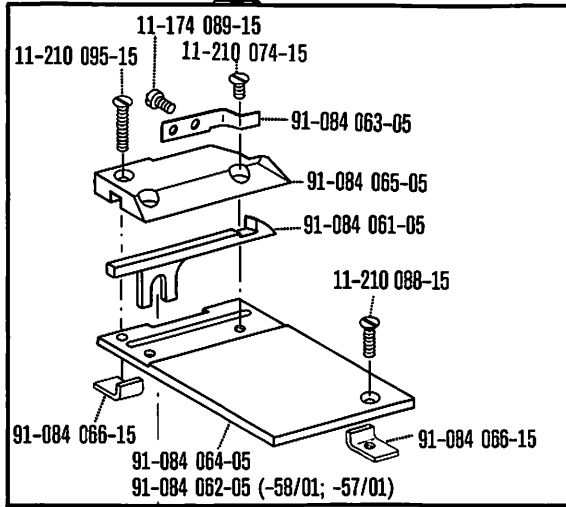

91-084 071-91

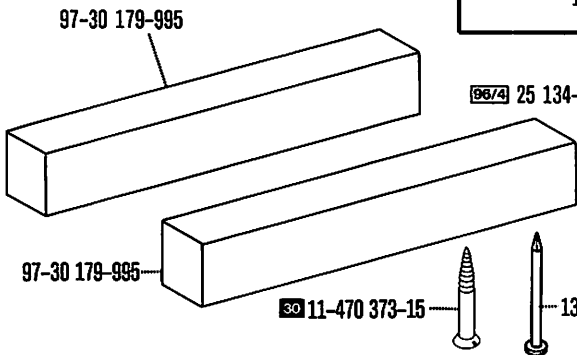
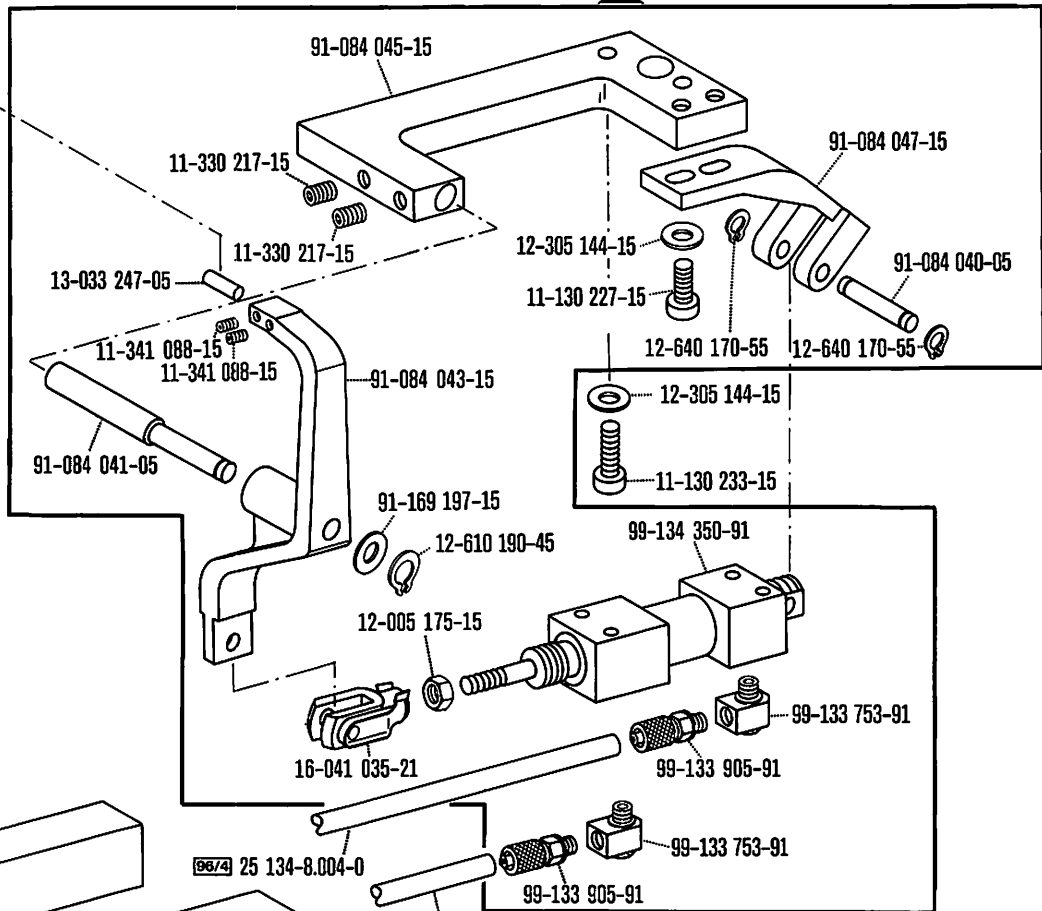

96/4 25 134-8.004-0

25 134-8.004-0 96/4

Einnadel · Single-needle
 Une aiguille · Aguja única

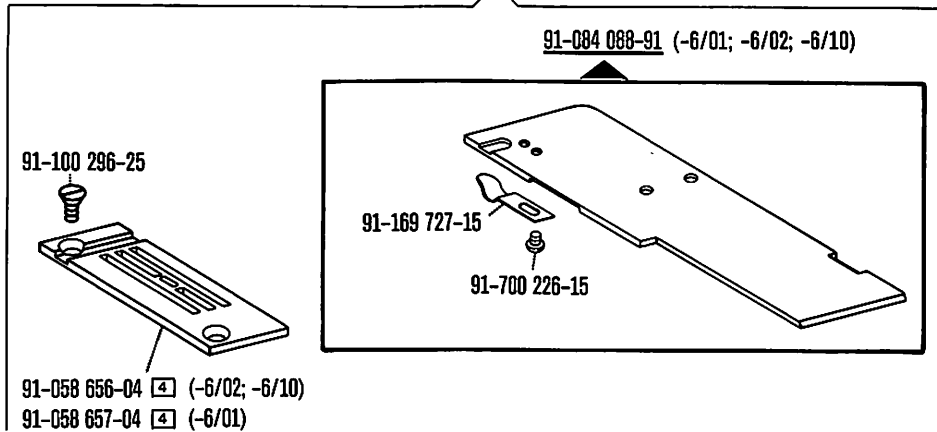

Zweinnadel · Two-needle
 Deux aiguille · Dos agujas

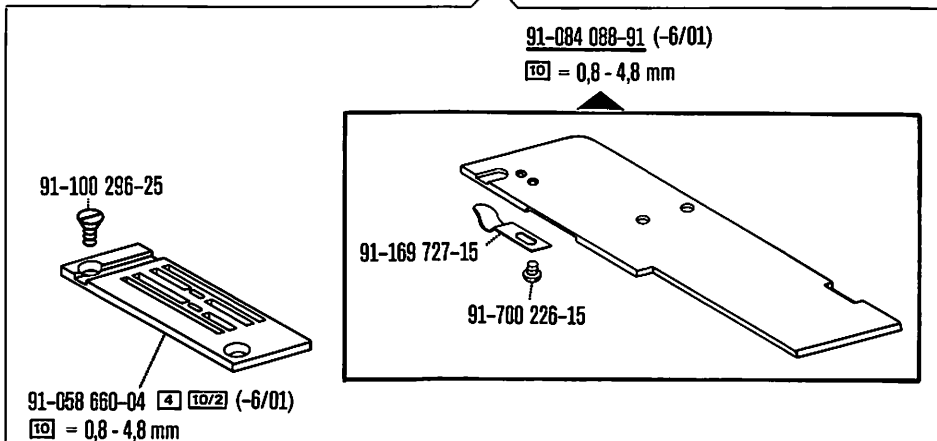

Zweinnadel · Two-needle
 Deux aiguilles · Dos agujas

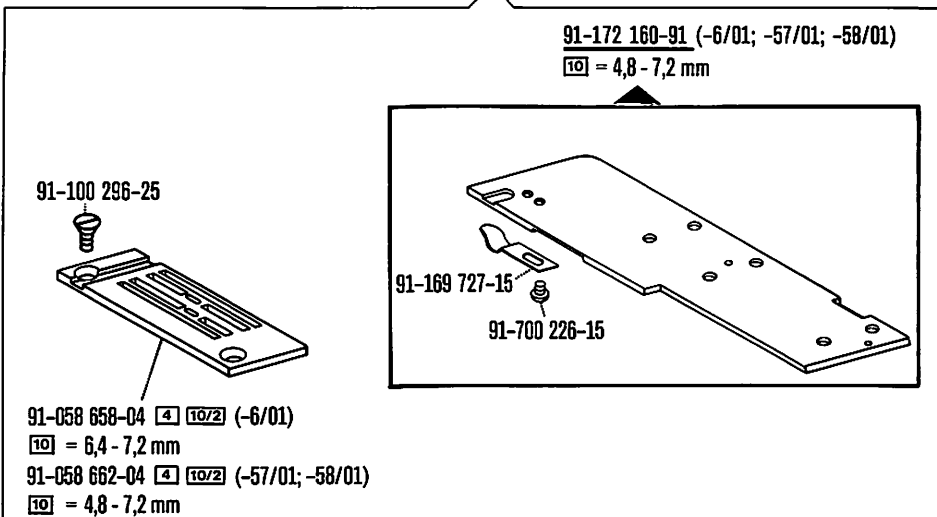

Kettentrenn-Einrichtung

Chain cutter

Coupe-chaînette

Cortador de cadena

-960/20

zur · pour
for · para

Pfaff 5483

Wartungseinheit -925/02 erforderlich

Conditioning unit -925/02 required

Conditionneur d'air comprimé -925/02 nécessaire

Requiere grupo acondicionador del aire comprimido -925/02

9.85

34

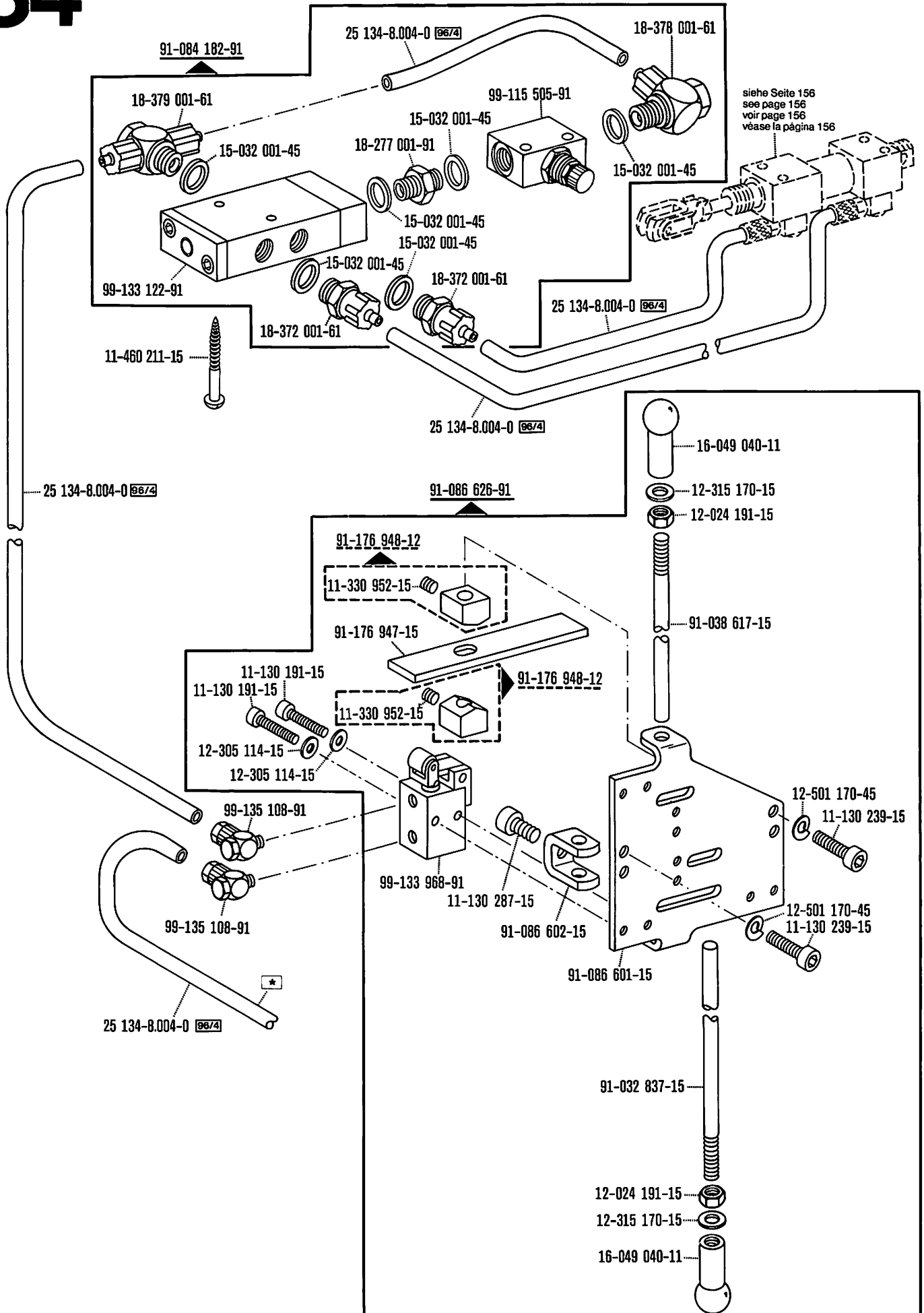

siehe Seite 156
see page 156
voir page 156
véase la página 156

* Zur Wartungseinheit
For conditioning unit
Pour la conditionneur d'air comprimé
Para las require grupo acondicionador del aire

siehe Erläuterungen Register O
see explanations on section O
voir légende registre O
ver explicaciones del registro O

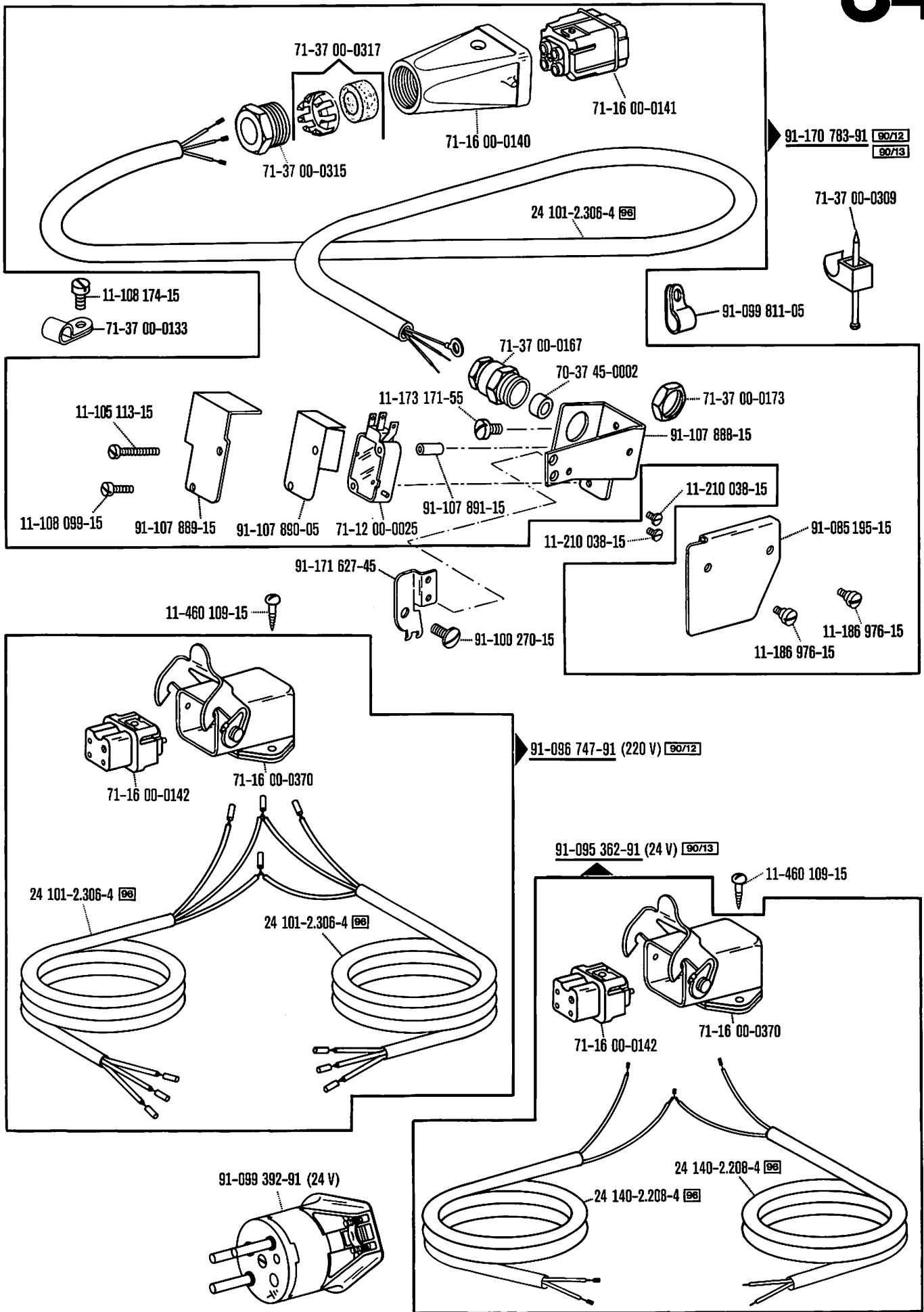

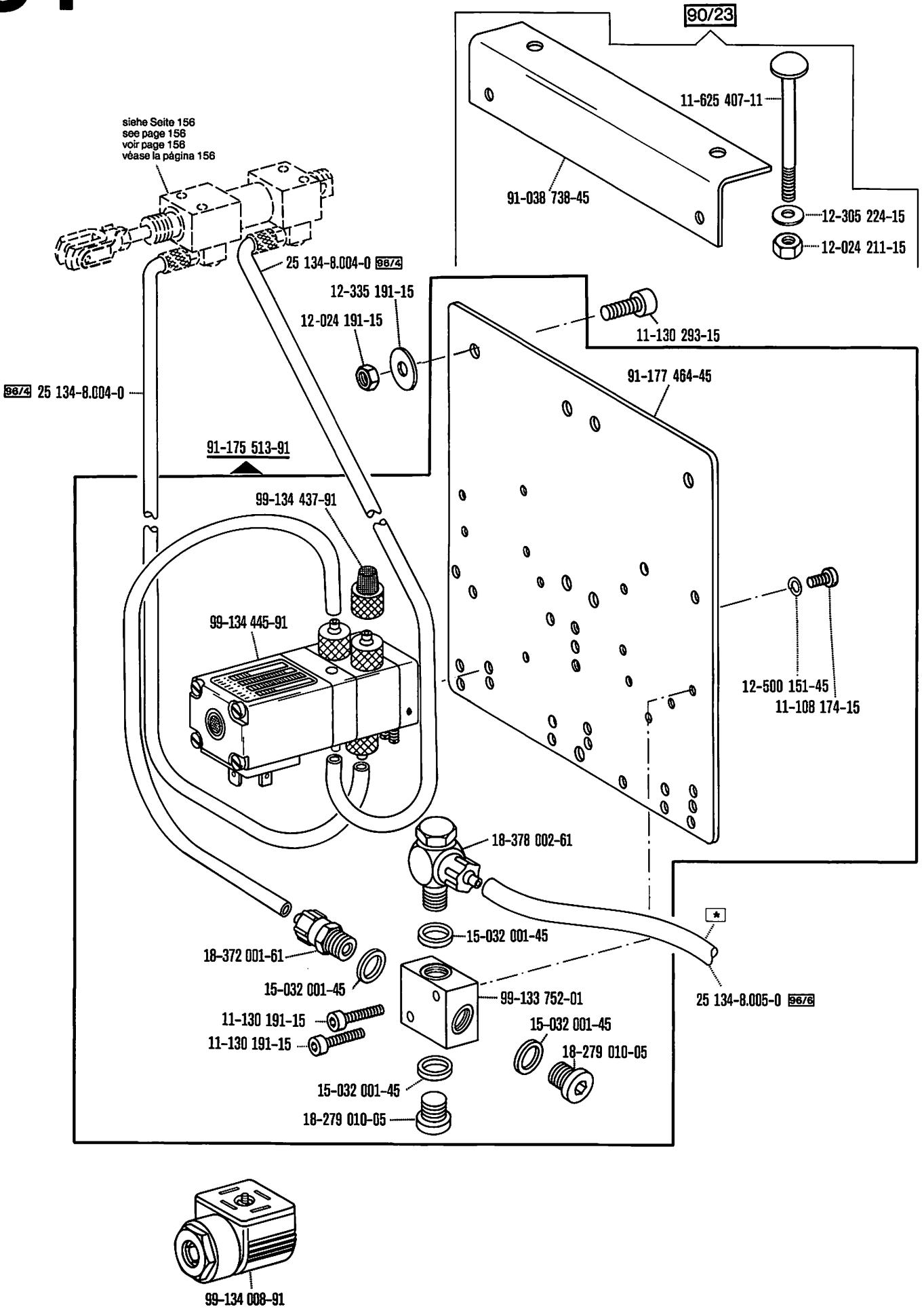

siehe Seite 156
 see page 156
 voir page 156
 véase la página 156

96/4 25 134-8.004-0

★

★ Zur Wartungseinheit
 For conditioning unit
 Pour la conditionneur d'air comprimé
 Para las require grupo acondicionador del aire

00-000 000-00 00-000 000-00 00-000 000-00

☐ siehe Erläuterungen Register O
 see explanations on section O
 voir légende registre O
 ver explicaciones del registro O

Kettentrenn-Einrichtung

Chain cutter

Coupe-chainette

Cortador de cadeneta

-960/22

zur · pour
for · para

Pfaff 5483

Wartungseinheit -925/02 erforderlich

Conditioning unit -925/02 required

Conditionneur d'air comprimé -925/02 nécessaire

Requiere grupo acondicionador del aire comprimido -925/02

9.85

34

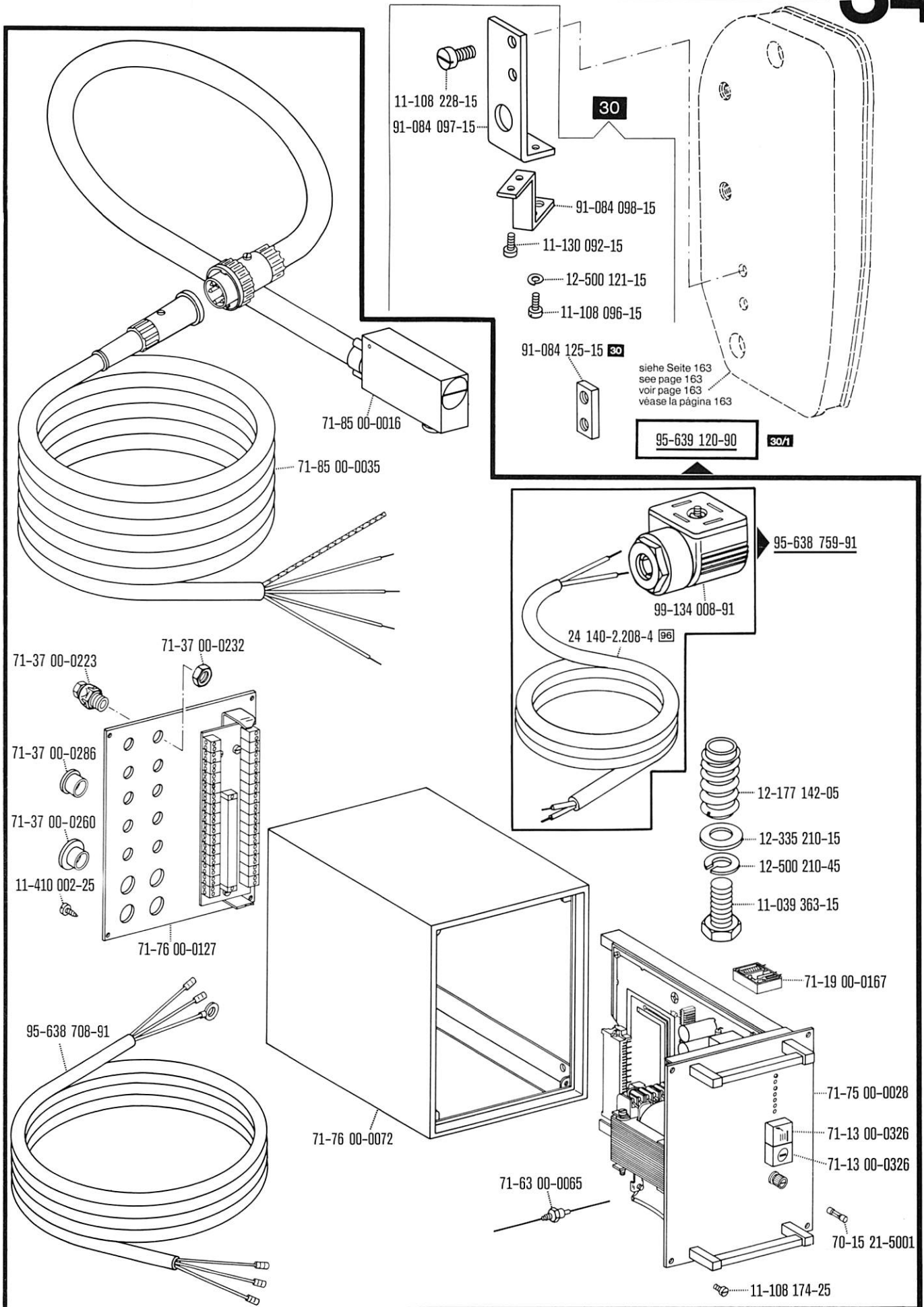

Kettentrenn-Einrichtung
Chain cutter
Coupe-chaînette
Cortador de cadeneta

-960/22

zur - pour
 for - para

Pfaff 5483

Wartungseinheit -925/02 erforderlich
 Conditioning unit -925/02 required
 Conditionneur d'air comprimé -925/02 nécessaire
 Requiere grupo acondicionador del aire comprimido -925/02

9.85

34

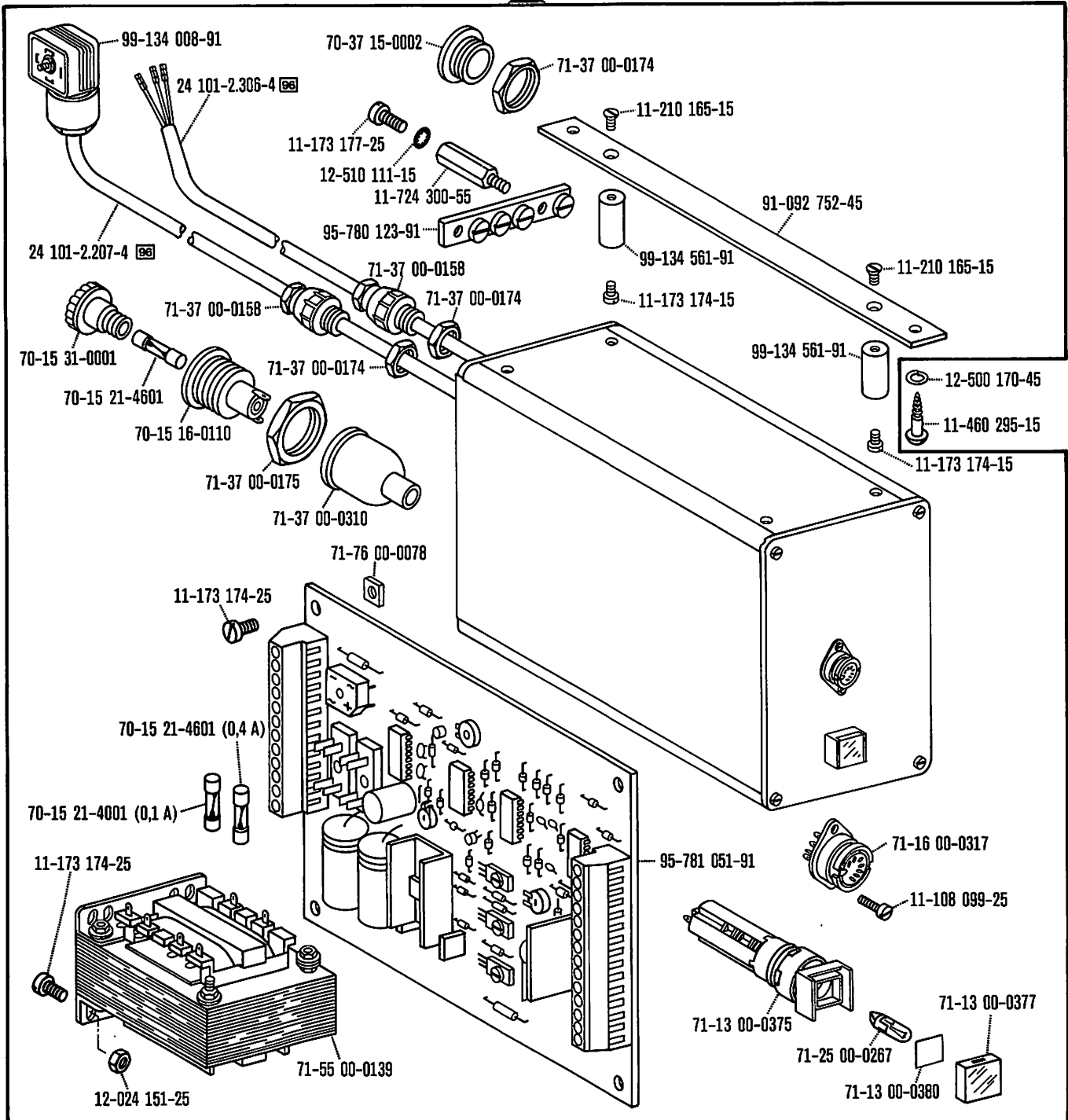
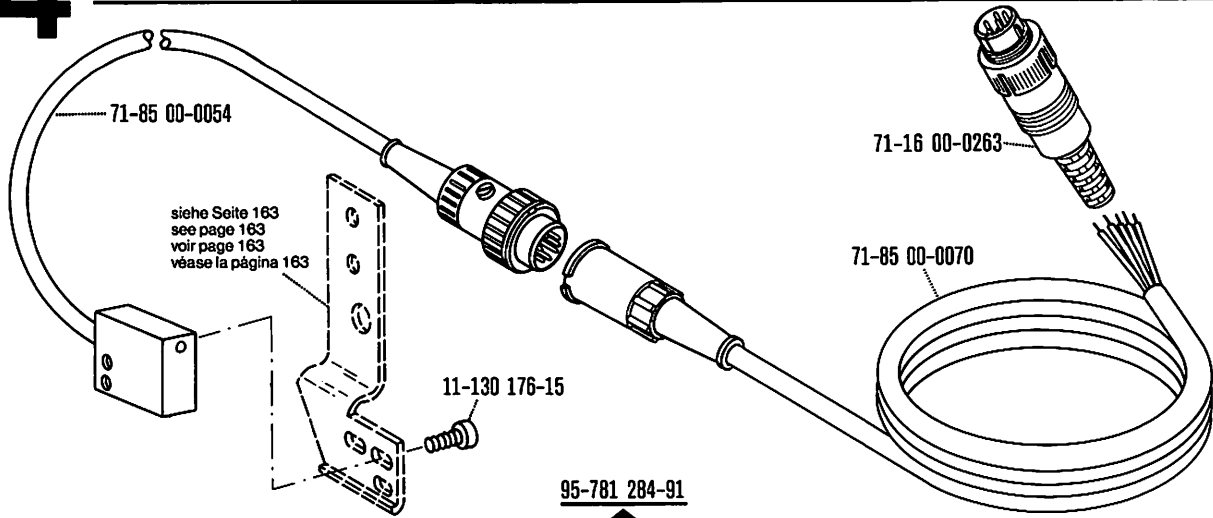

Kettentrenn-Einrichtung

Chain cutter

Coupe-chaînette

Cortador de cadeneta

-960/22

zur · pour
for · para

Pfaff 5483

Wartungseinheit -925/02 erforderlich

Conditioning unit -925/02 required

Conditionneur d'air comprimé -925/02 nécessaire

Requiere grupo acondicionador del aire comprimido -925/02

9.85

34

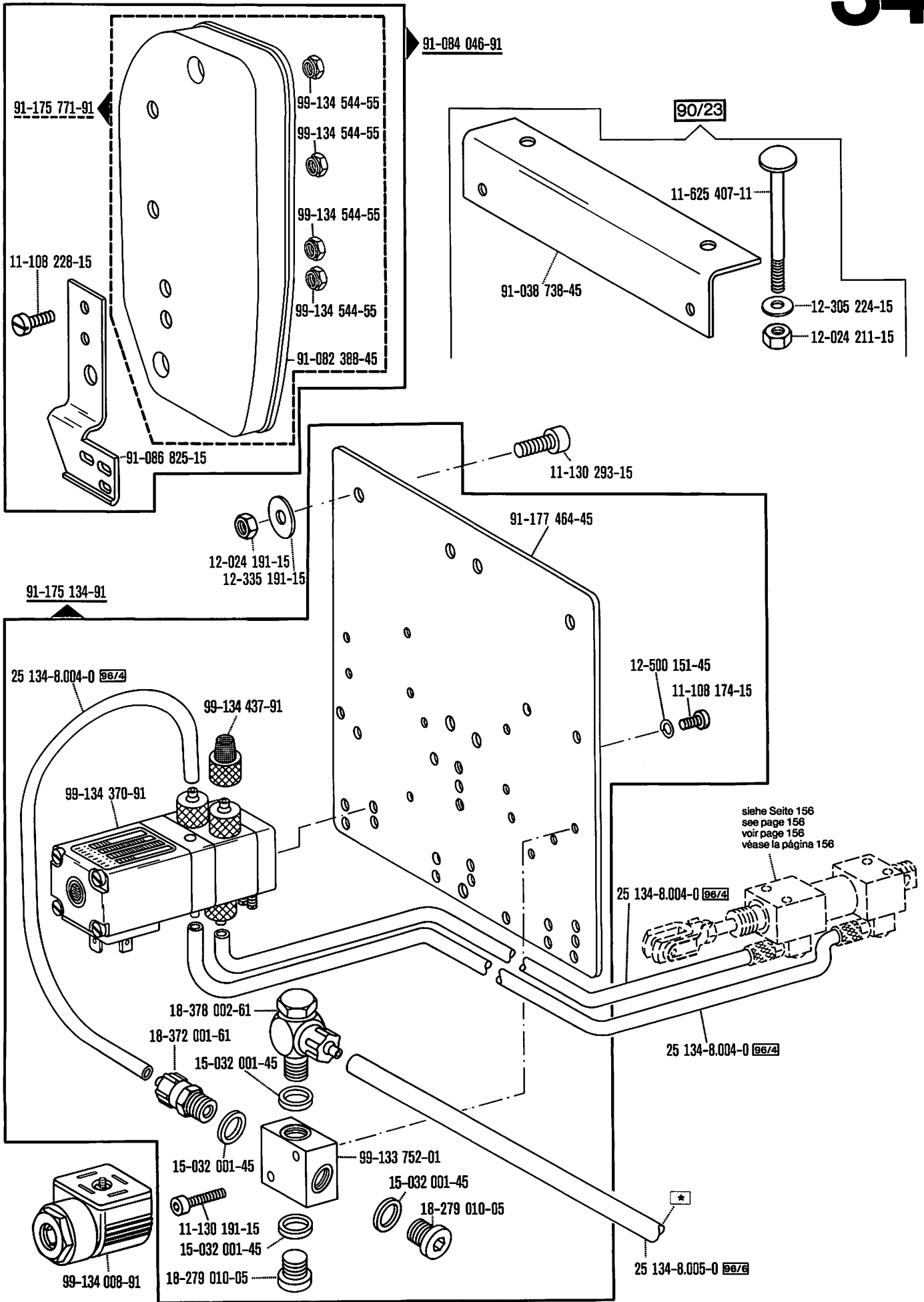

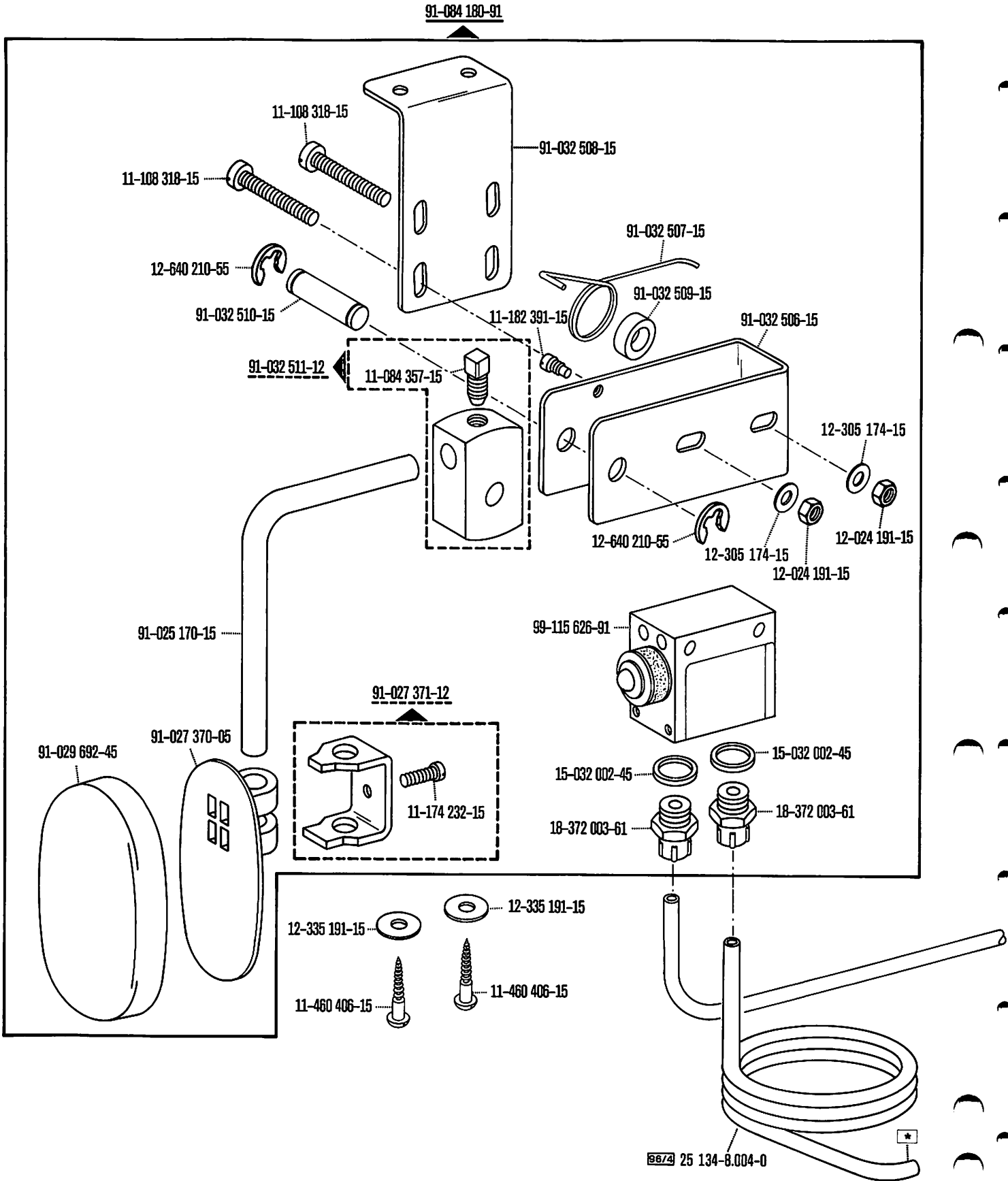

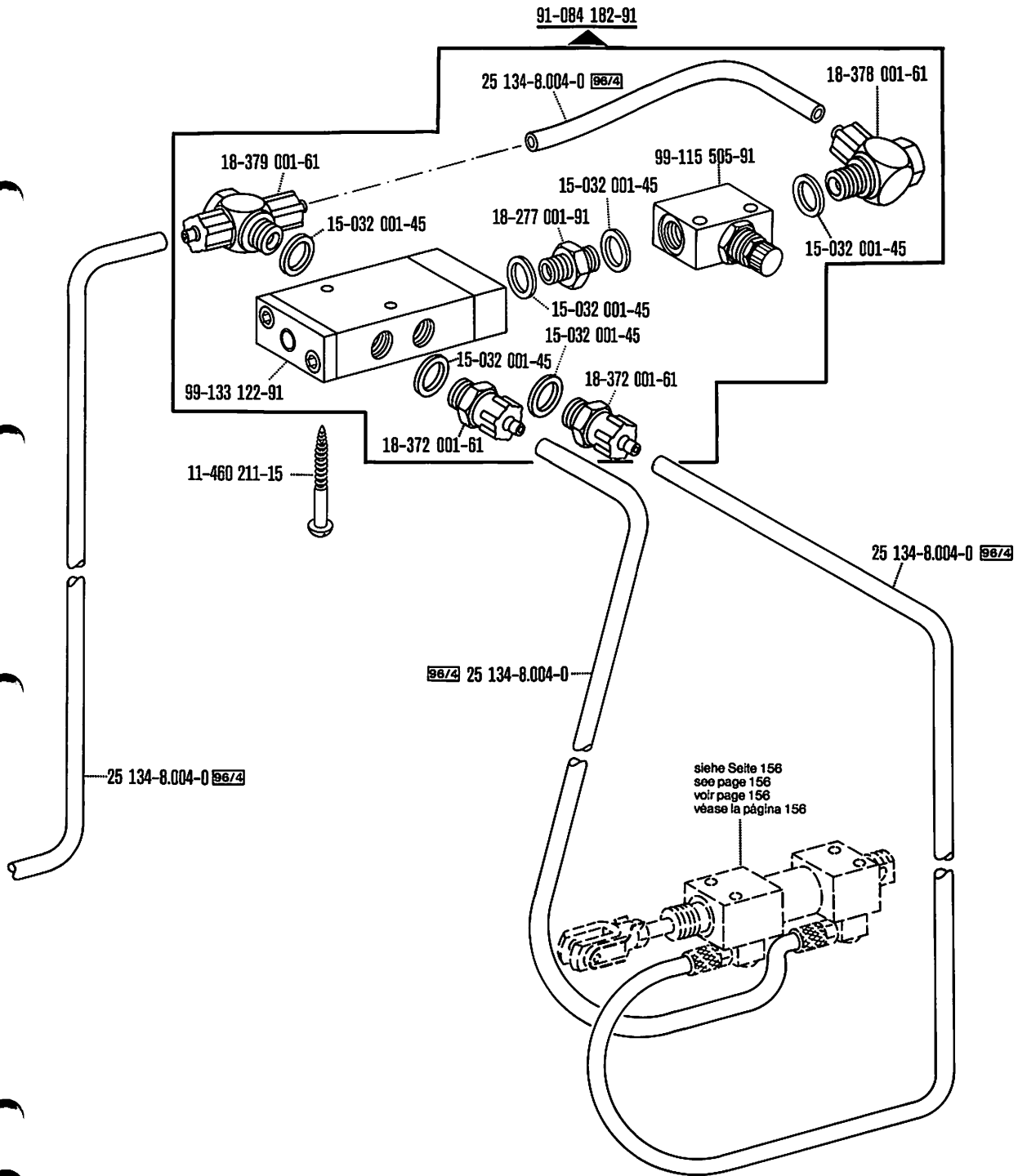

91-168 222-11

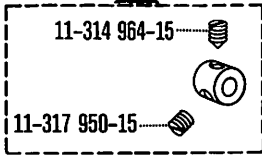

siehe Seite 20
see page 20
voir page 20
véase la página 20

91-082 301-45

11-210 226-15

7/16

11-130 287-15

11-130 287-15

11-210 226-15

91-084 440-45 (-814/06-61/05)

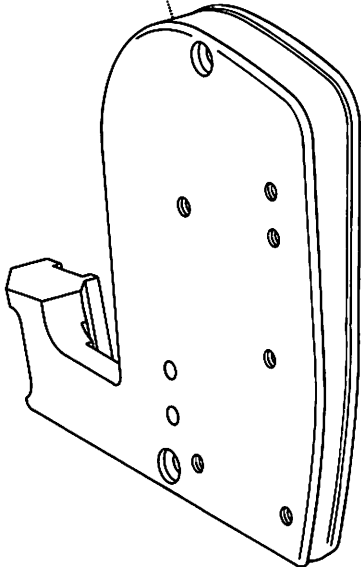

* 91-082 320-91

** 91-082 300-91

- * -814/01-17/31;
- 814/01-39/31;
- 814/01-69/01;
- 814/01-82/12;
- 814/01-733/01-39/31;
- 814/02-45/02;
- 814/06-61/05;
- 814/06-94/01

- ** -818/55-6/01;
- 818/55-32/01

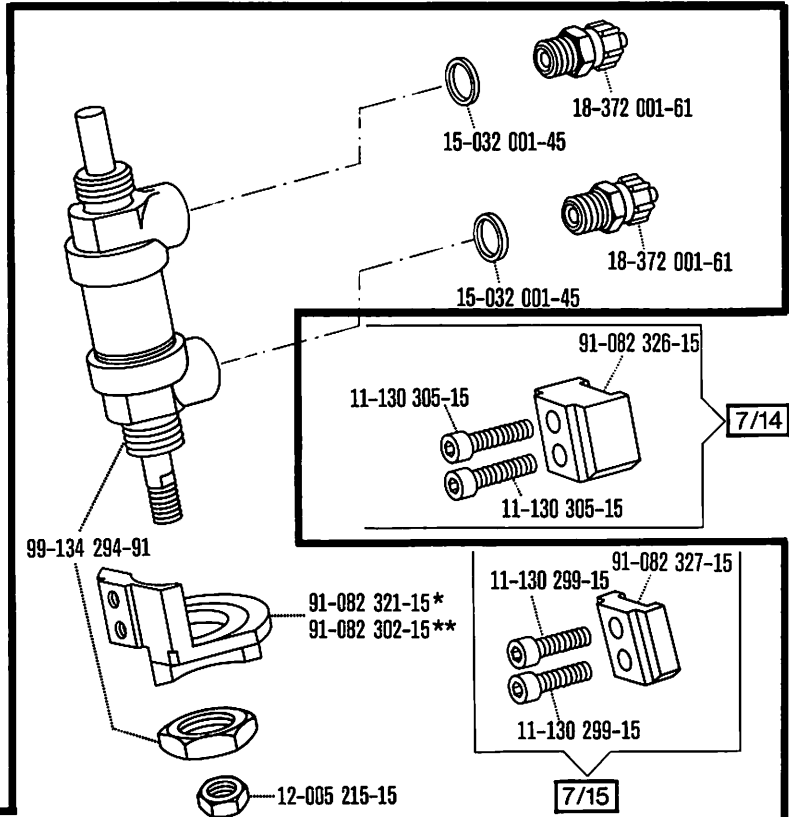

15-032 001-45

18-372 001-61

15-032 001-45

18-372 001-61

91-082 326-15

11-130 305-15

11-130 305-15

7/14

99-134 294-91

91-082 321-15*

91-082 302-15**

91-082 327-15

11-130 299-15

11-130 299-15

7/15

12-005 215-15

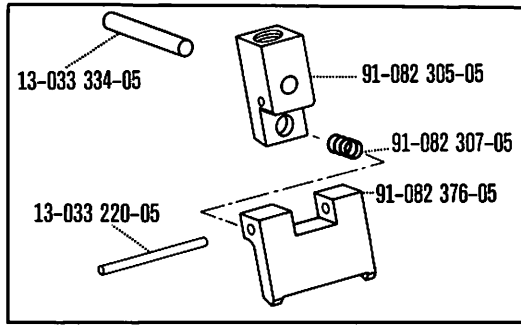

13-033 334-05

91-082 305-05

91-082 307-05

91-082 358-01

13-033 220-05

91-082 376-05

91-082 308-91

91-082 309-15

12-305 114-15

12-500 151-45

11-108 177-15

91-082 303-91

12-500 151-45

11-108 177-15

12-305 114-15

91-021 006-15

99-133 905-91

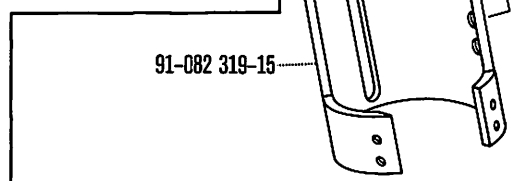

91-082 319-15

91-082 328-15

12-305 084-15

12-500 121-45

11-108 090-15

11-108 090-15

12-305 084-15

12-500 121-45

12-305 084-15

91-082 329-15

12-500 121-45

12-305 084-15

11-108 090-15

12-500 121-45

91-082 858-05

11-108 090-15

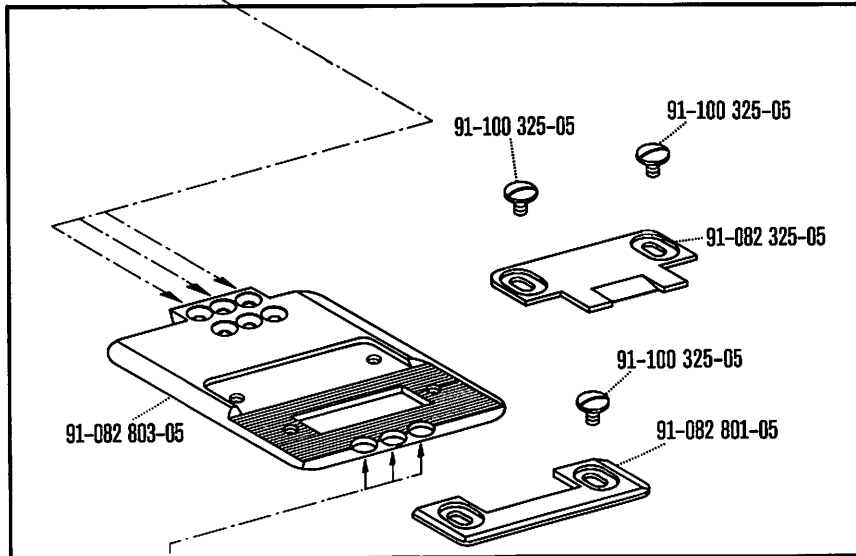
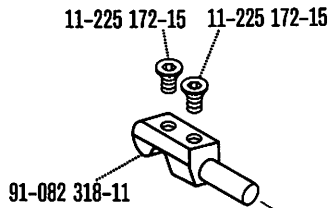

91-082 802-01 (-814/01-17/31;
-814/01-39/31;
-814/01-69/01;
-814/01-82/12;
-814/02-45/02;
-814/06-61/05;
-814/06-94/01)

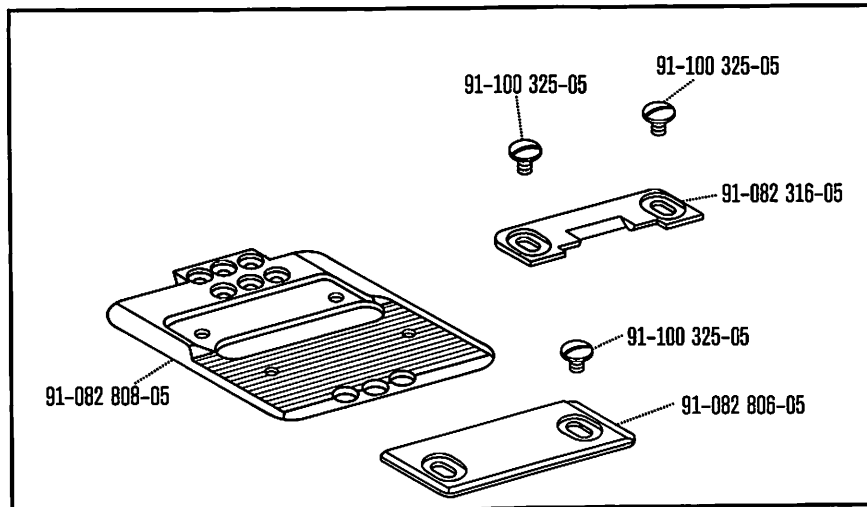
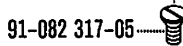

91-082 807-01 (-818/55-6/01;
-818/55-32/01)

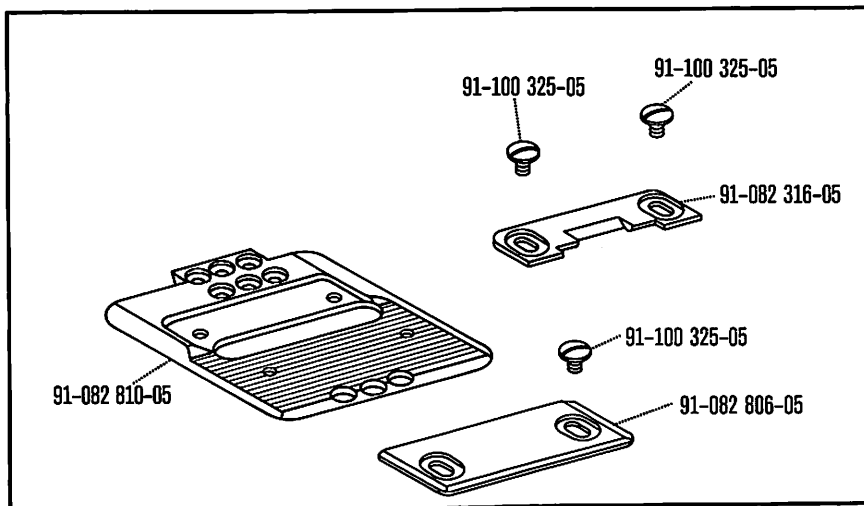

91-082 809-01 (-814/01-733/01
-17/31;
-814/01-733/01
-39/31)

91-084 441-91 (-818/55-6/01;
□ = 6,4; 7,2 mm -818/55-32/01)

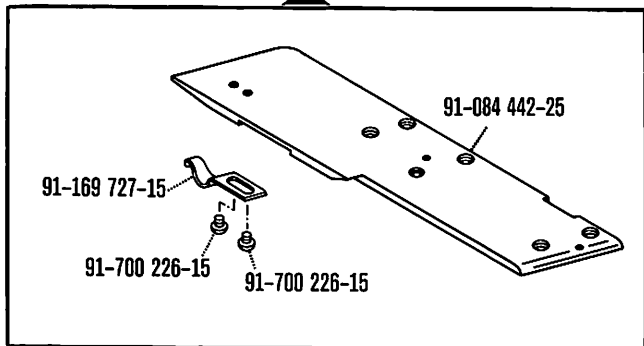

91-084 444-91 (-814/01-69/01;
□ = 4,8 mm -814/02-45/02;
-818/55-6/01;
-818/55-32/01)

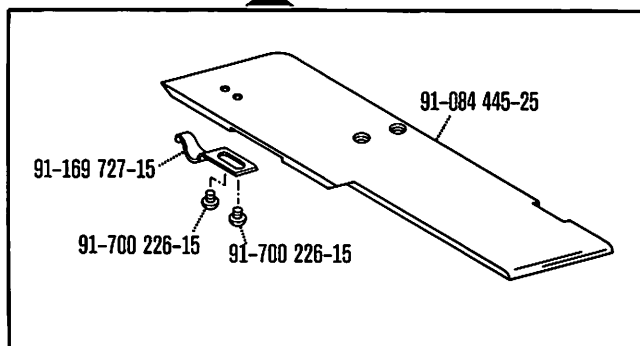

91-082 304-91 (-814/01-733/01-17/31;
-814/01-733/01-39/31)

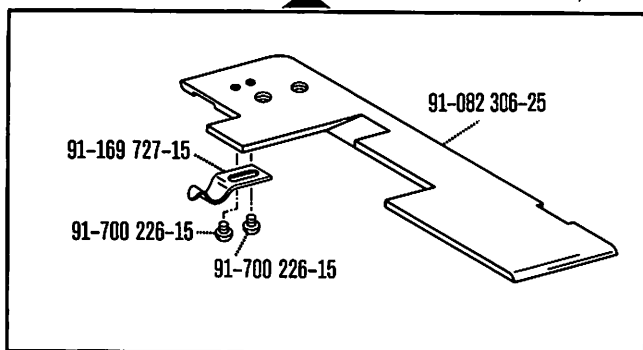

91-084 818-91 (-814/01-82/12)

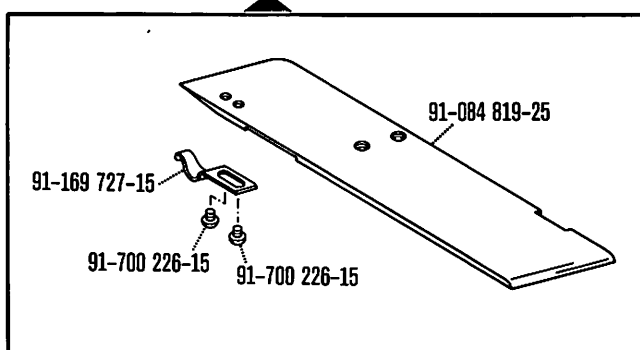

91-084 820-91 (-814/01-17/31;
-814/01-39/31)

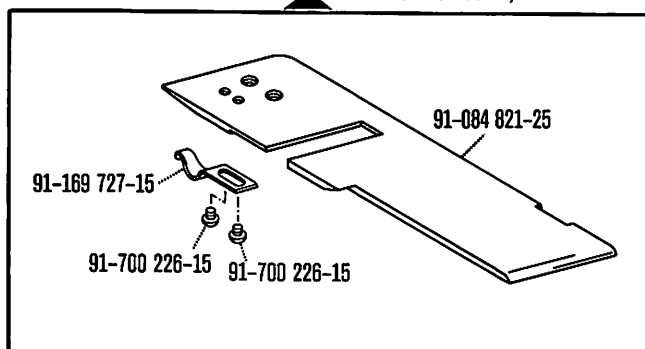

91-084 448-91 (-814/06-61/05;
-814/06-94/01)

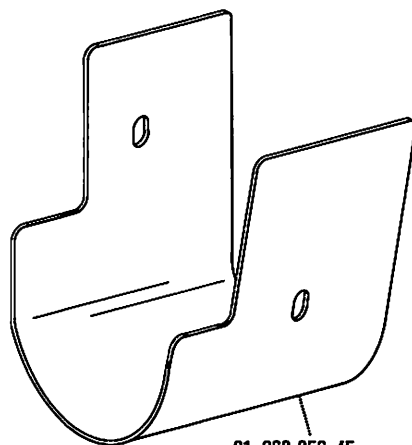
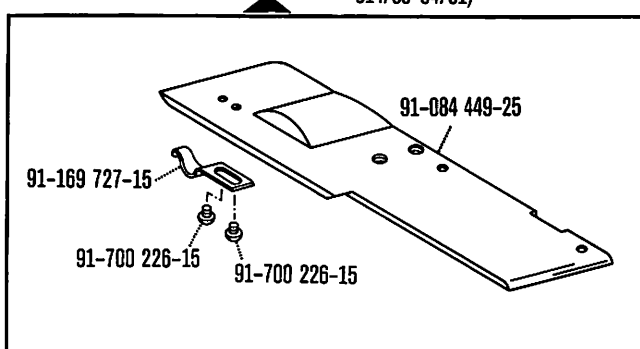

91-082 356-45
(-814/01-733/01-17/31;
-814/01-733/01-39/31)

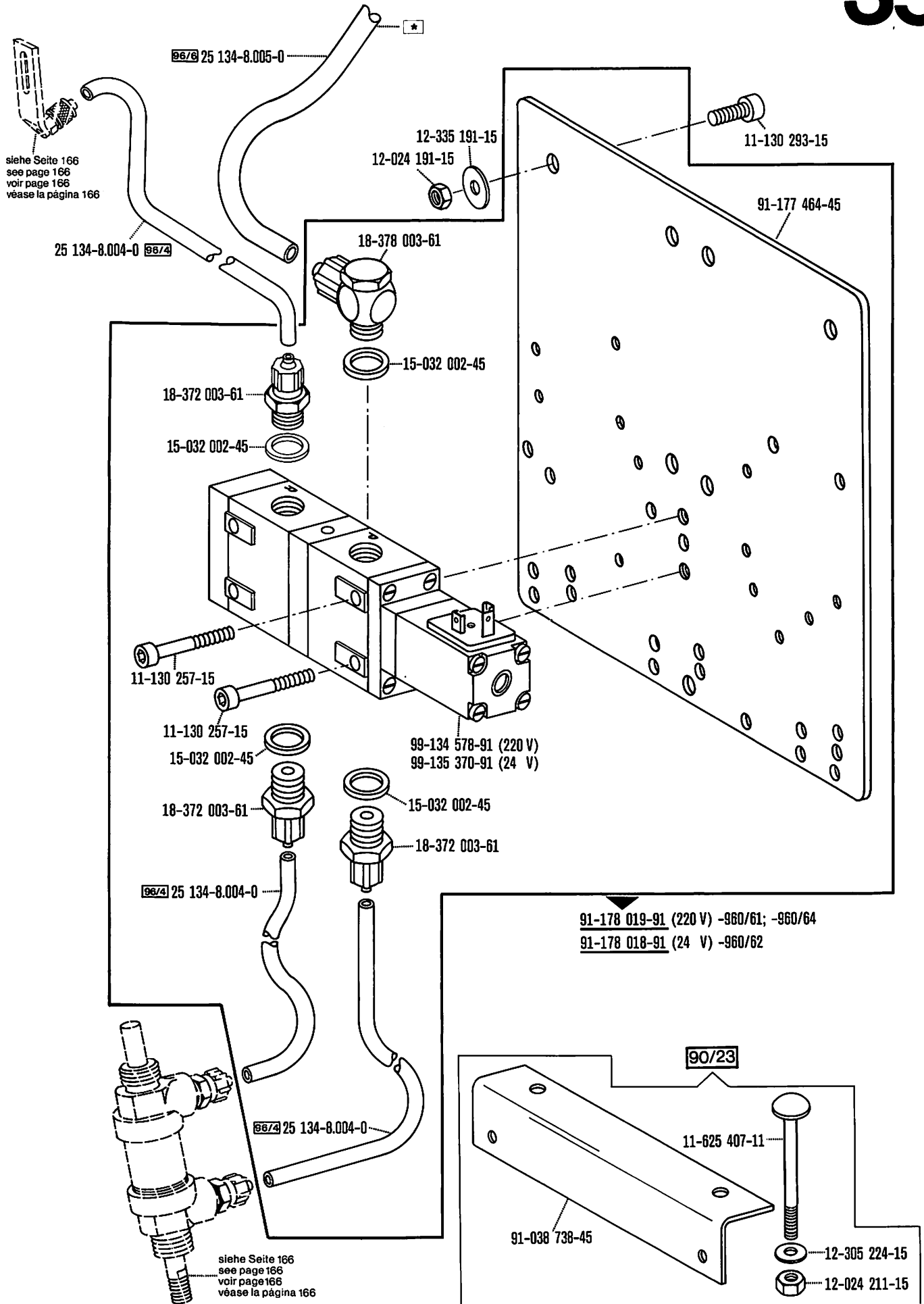

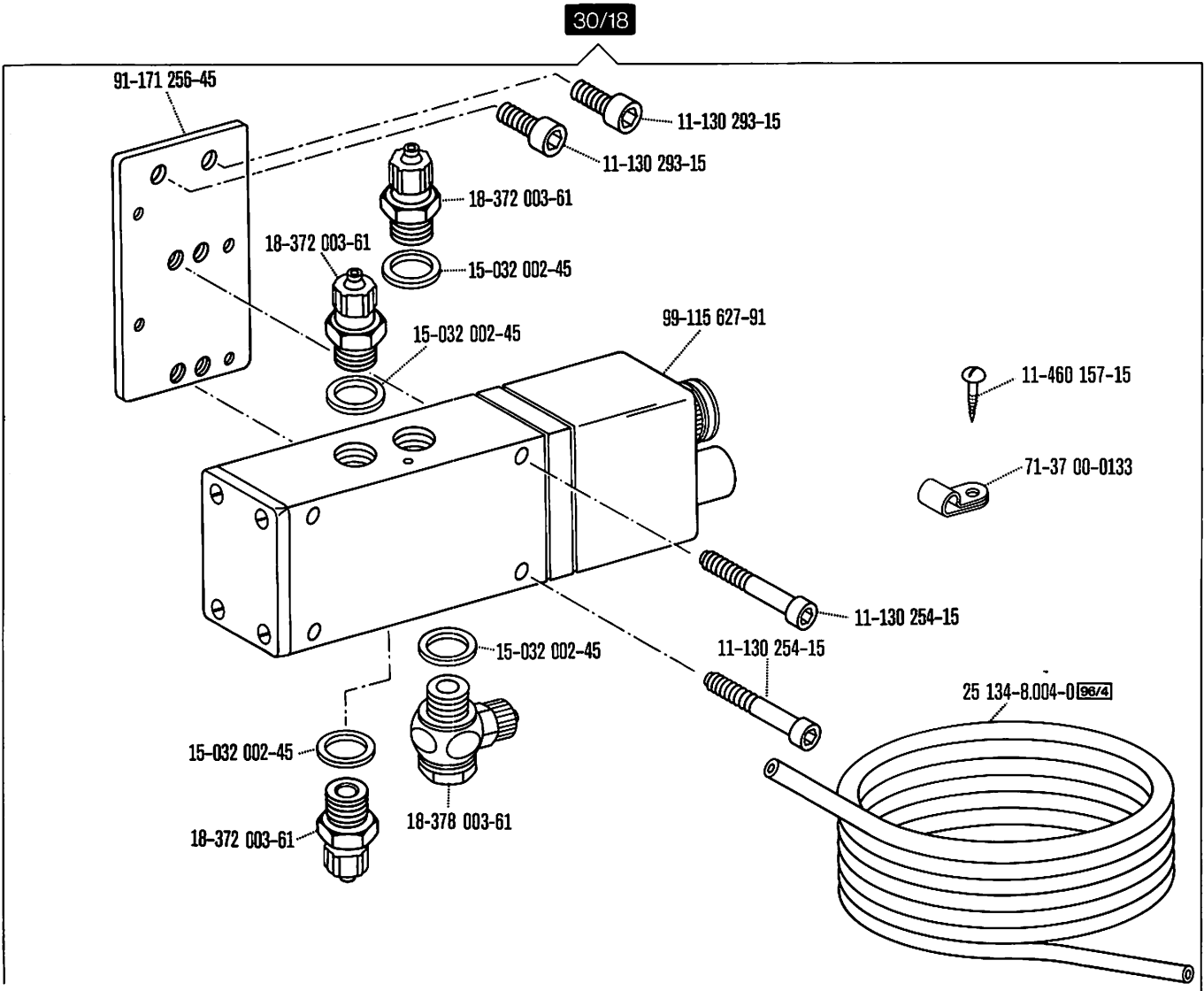

91-092 210-91 (80/11)

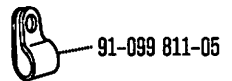
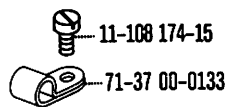
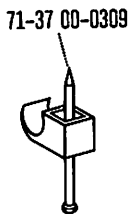
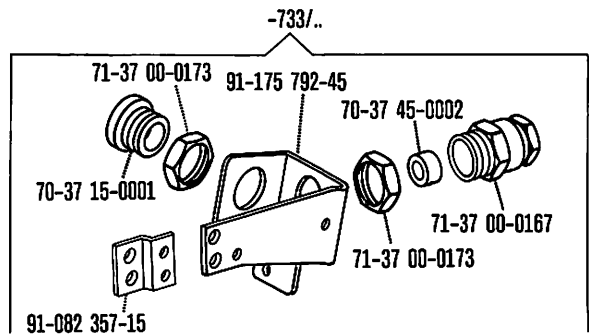
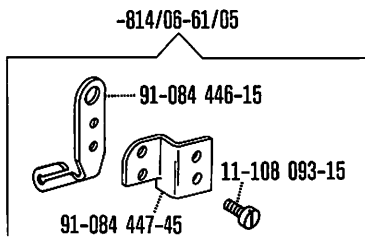
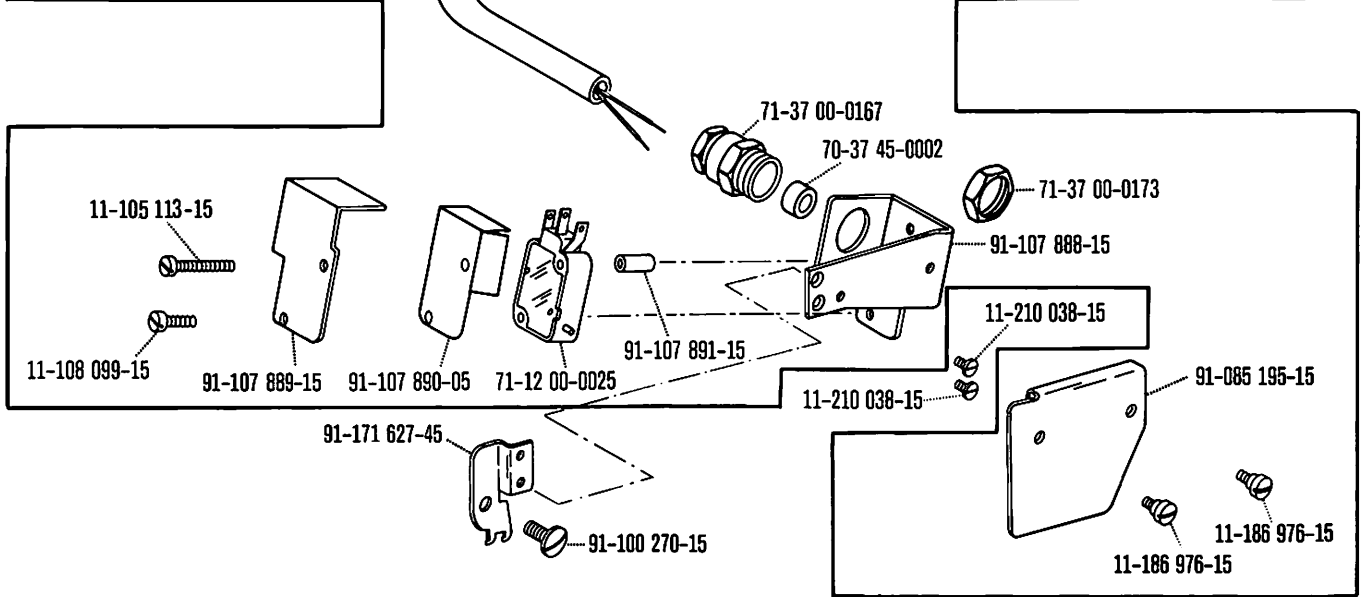
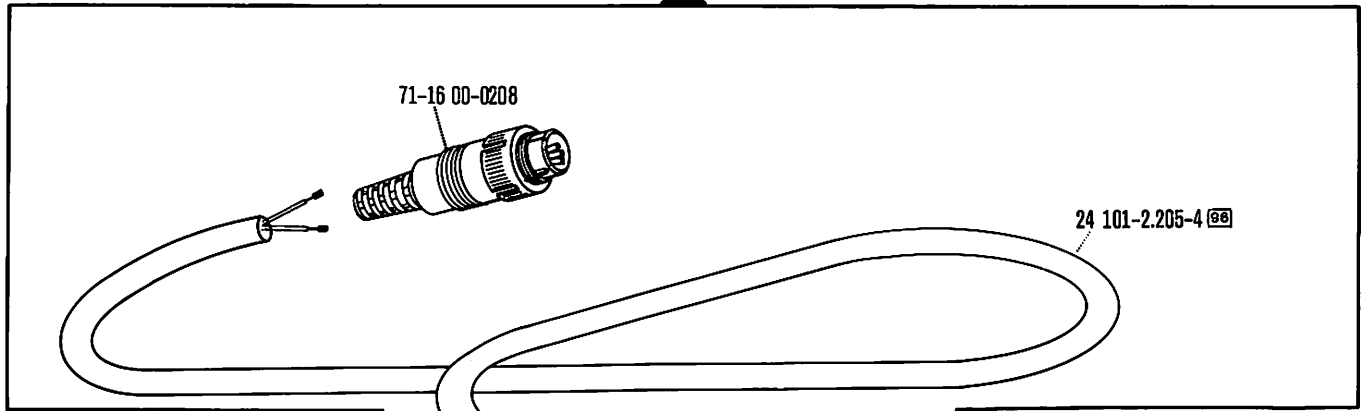

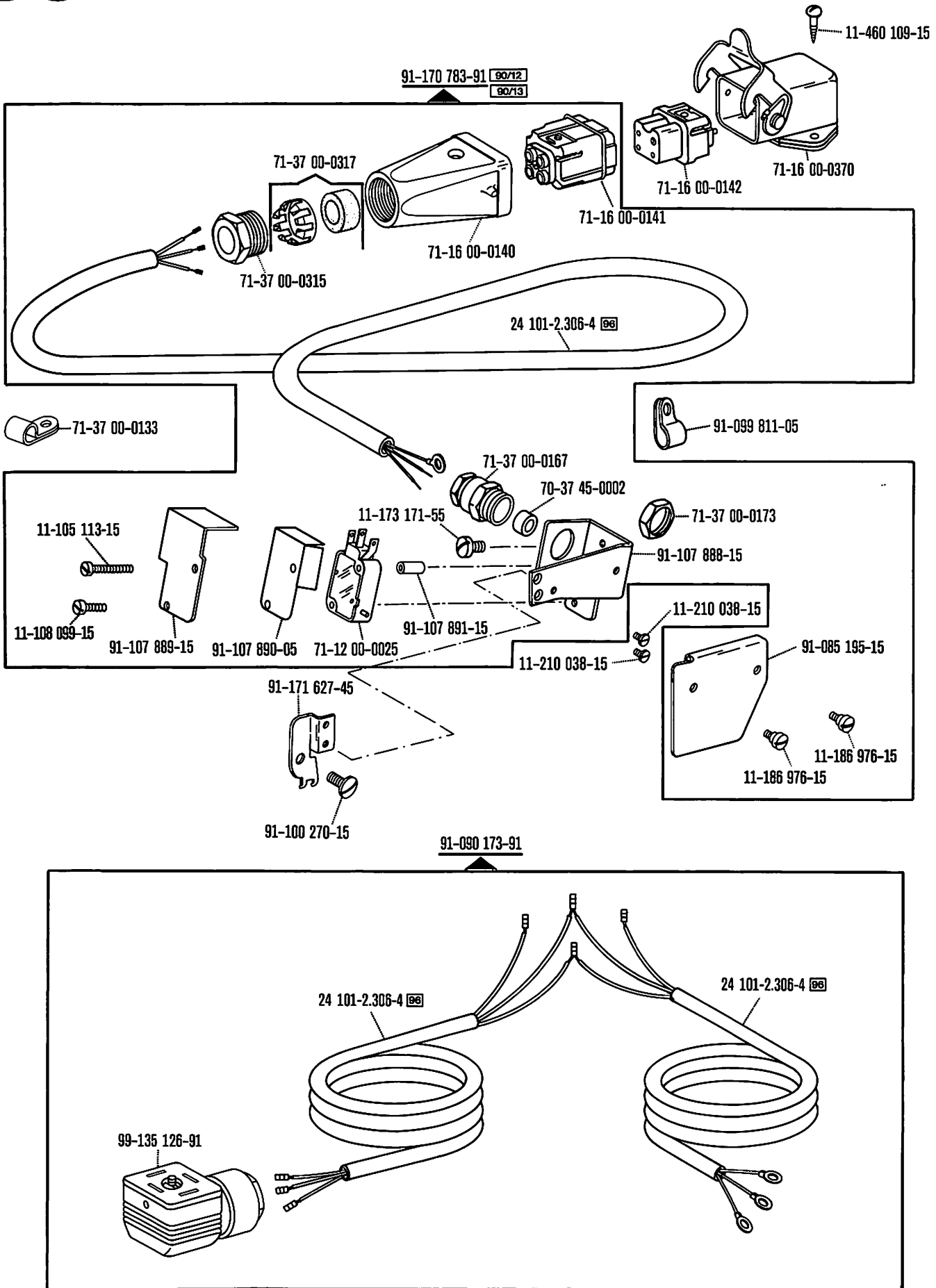

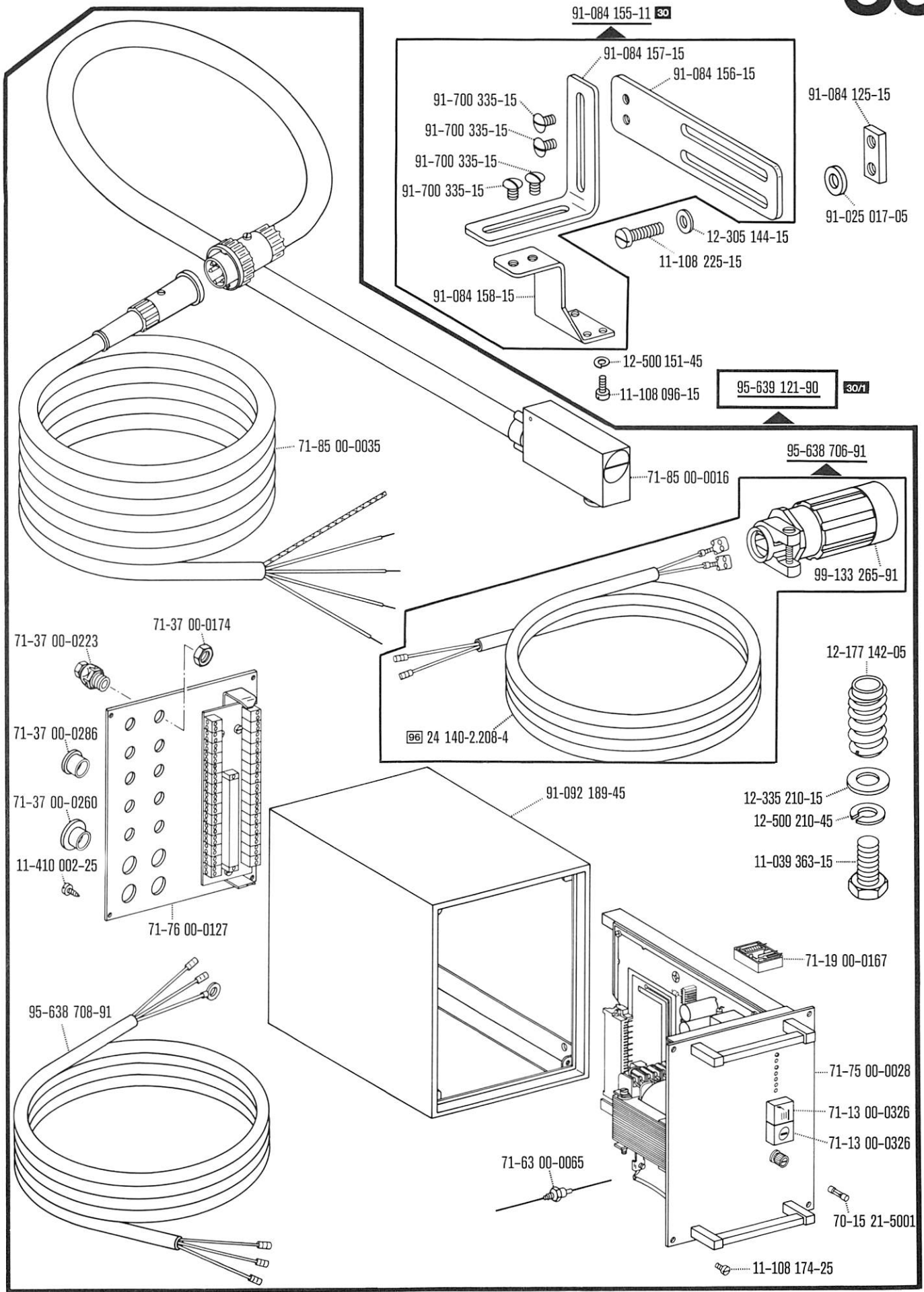

00-000 000-00 00-000 000-00 00-000 000-00 siehe Erläuterungen Register 0
 see explanations on section 0
 voir légende registre 0
 ver explicaciones del registro 0

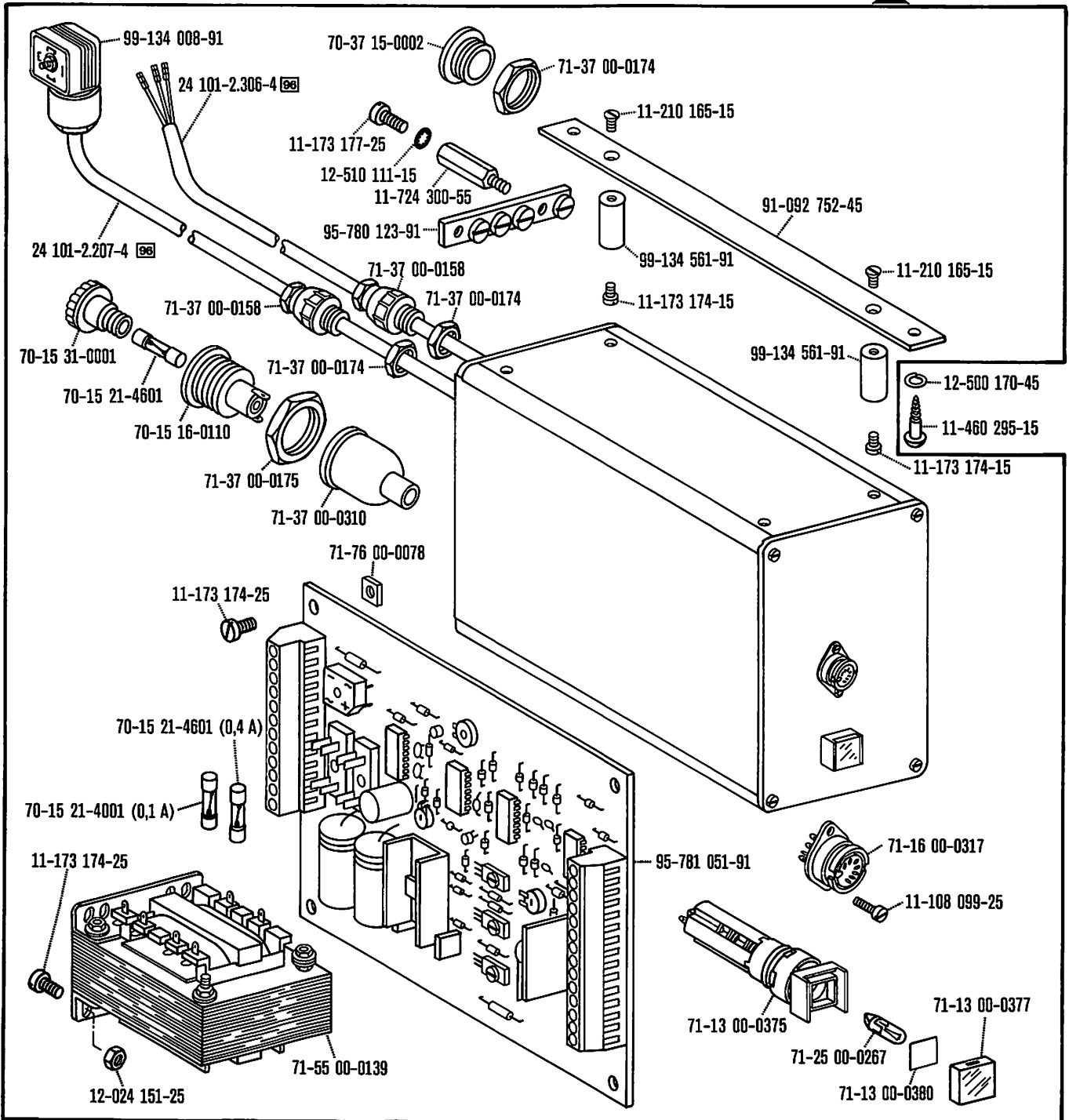
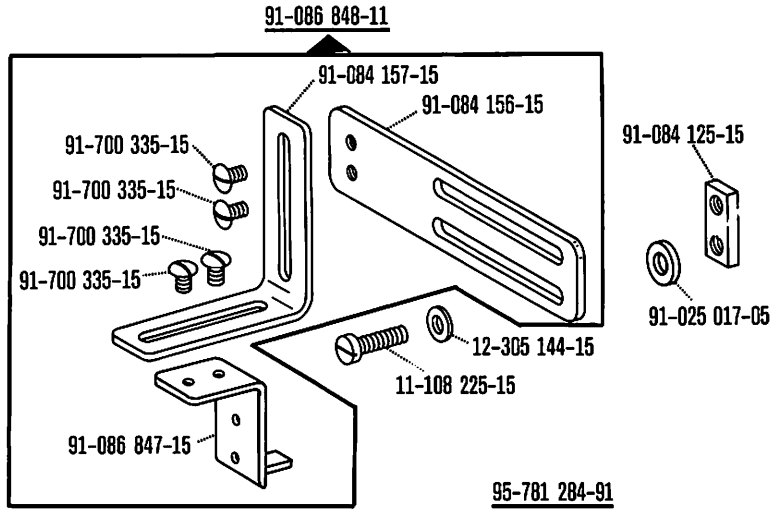
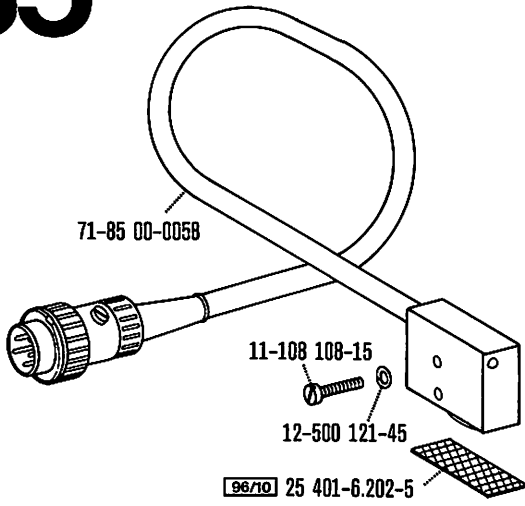

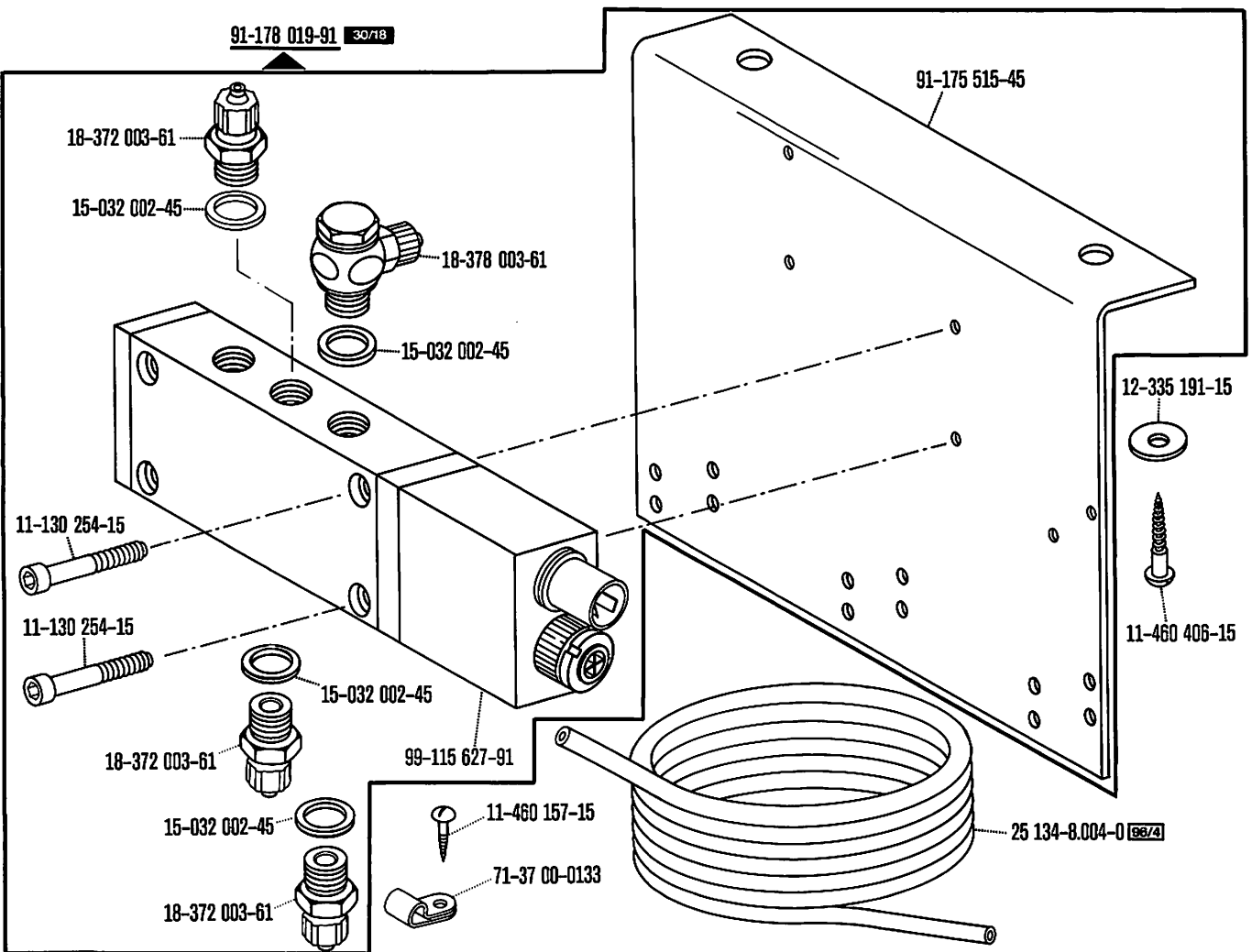
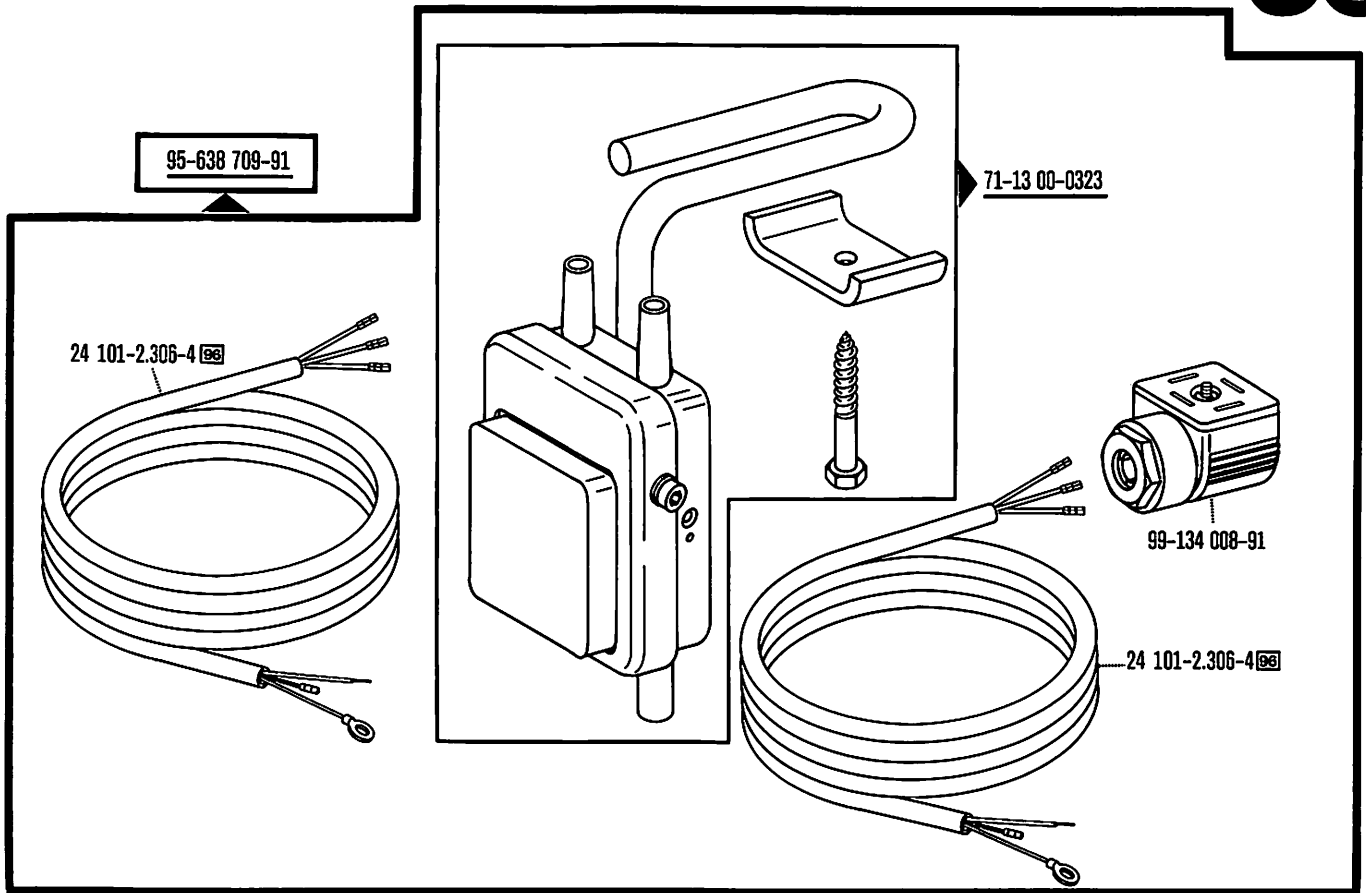

00-000 000-00 00-000 000-00 00-000 000-00 siehe Erläuterungen Register O
 see explanations on section O
 voir légende registre O
 ver explicaciones del registro O

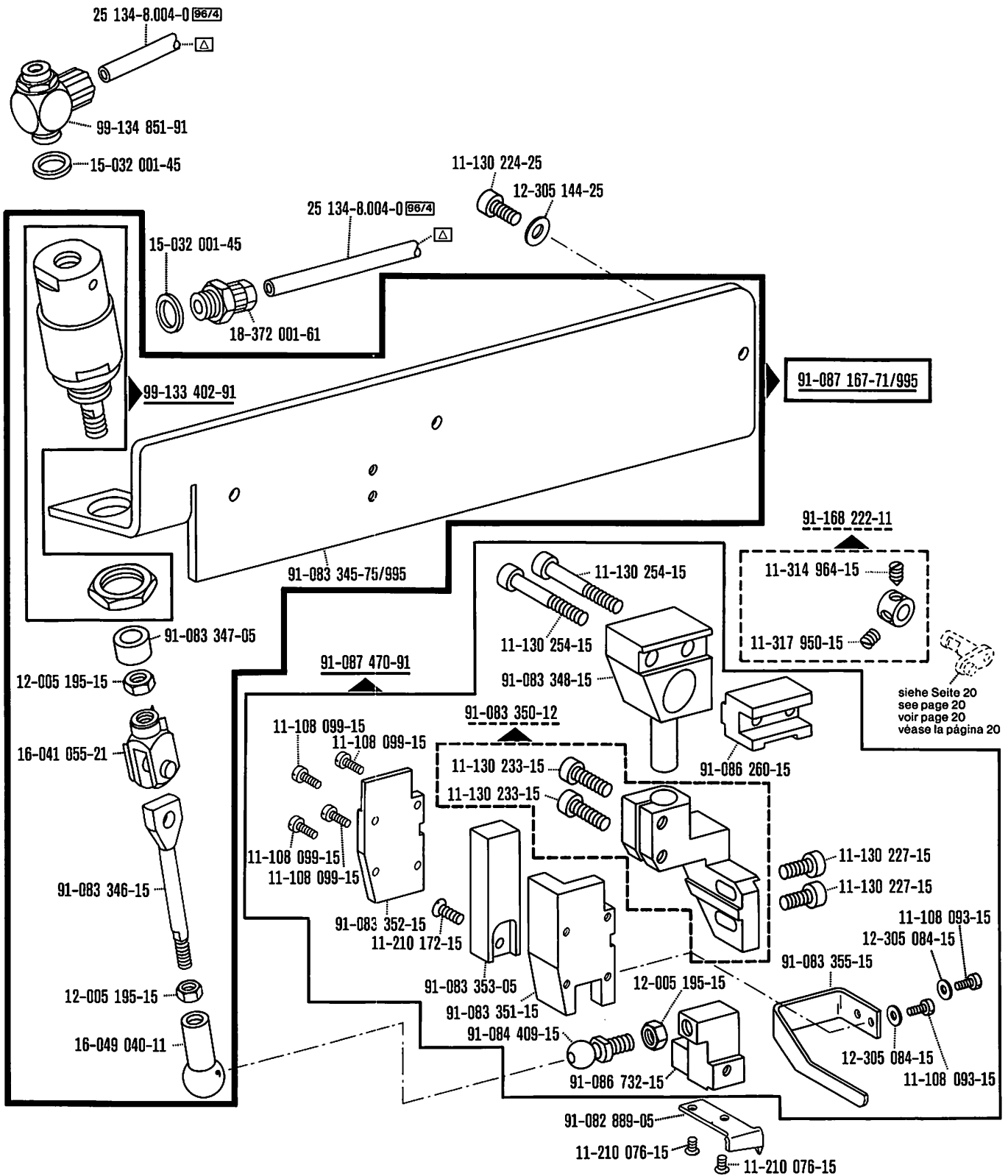

Bandtrenn-Einrichtung

Tape cutter

Coupe-ruban

Cortador de cintas

-960/81

-960/82

-960/84

zur · pour
for · para

Pfaff 5483-731/...;-733/..

Wartungseinheit -925/02 erforderlich

Conditioning unit -925/02 required

Conditionneur d'air comprimé -925/02 nécessaire

Requiere grupo acondicionador del aire comprimido -925/02

9.85

36

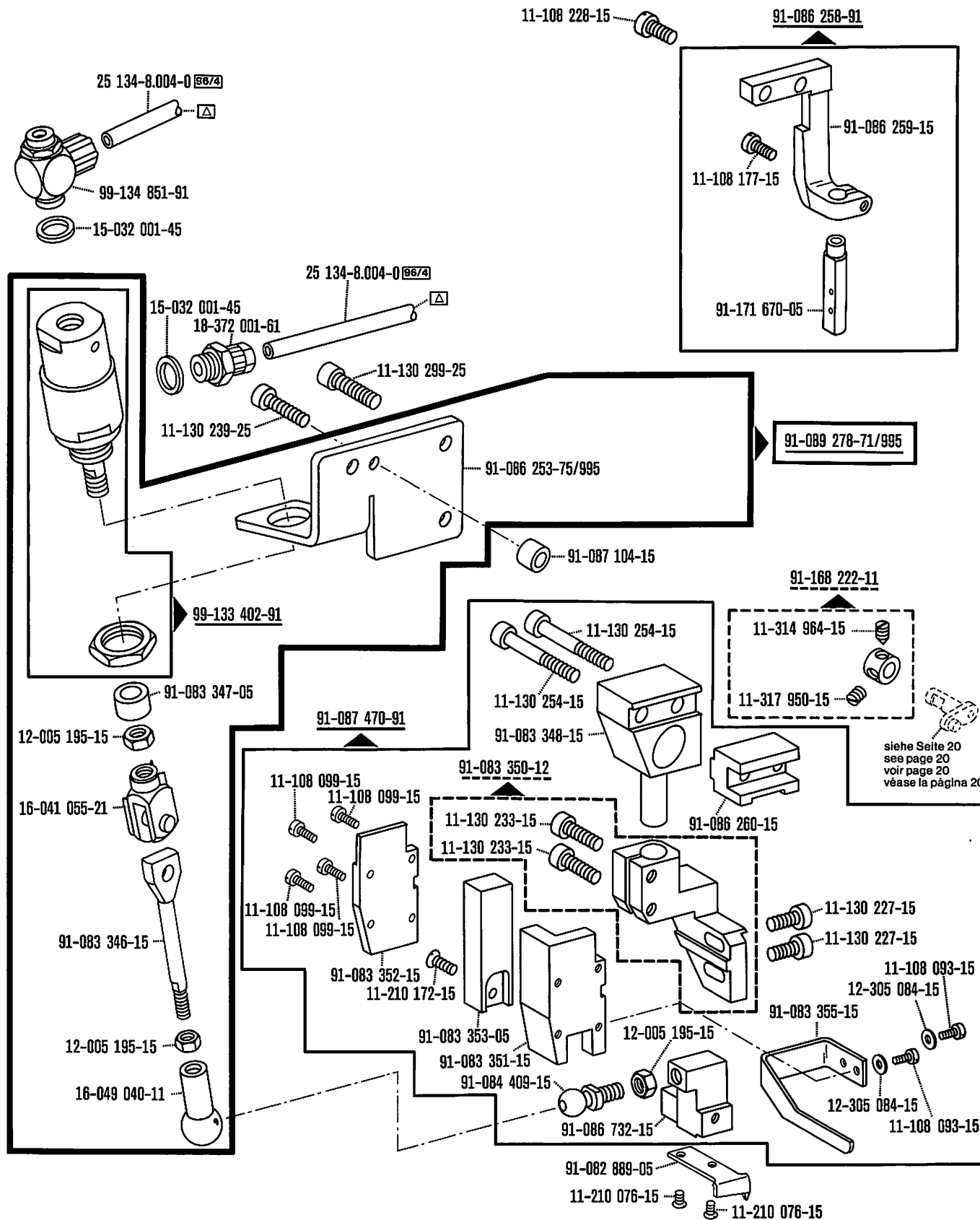

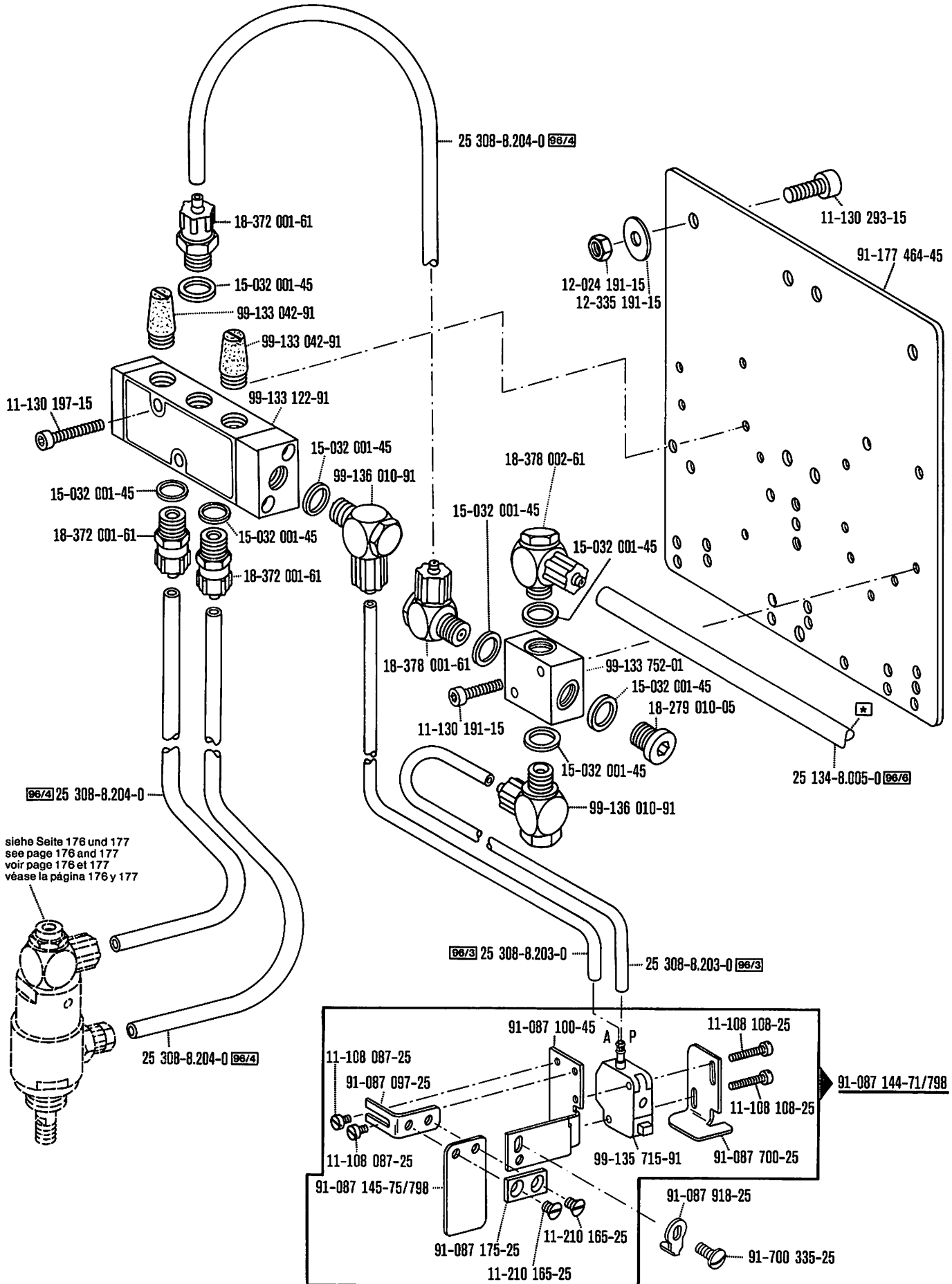

siehe Seite 176 und 177
 see page 176 and 177
 voir page 176 et 177
 véase la página 176 y 177

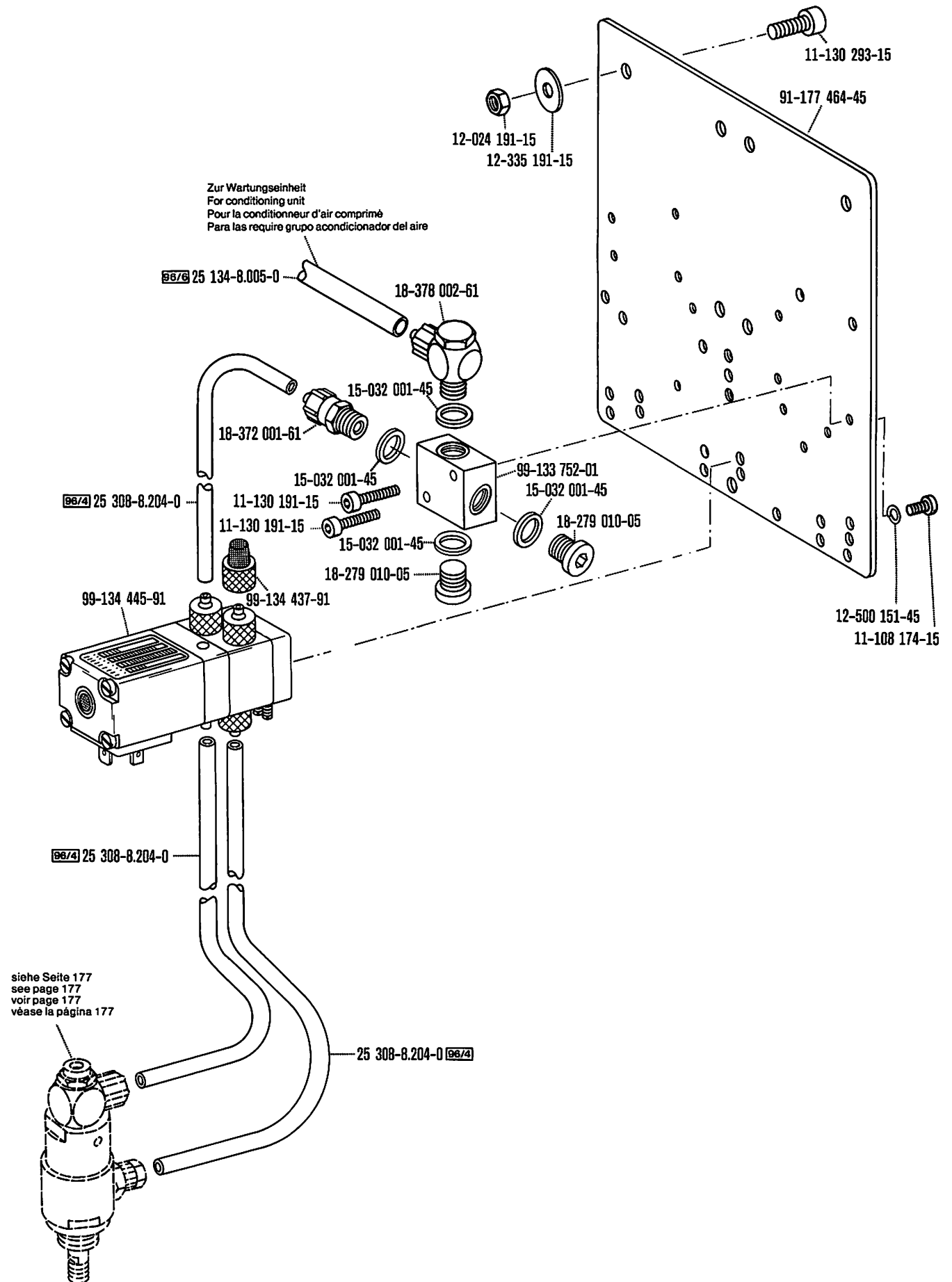

Fotozelle
Photocell
Cellule photo-électrique
Fotocélula

Efka

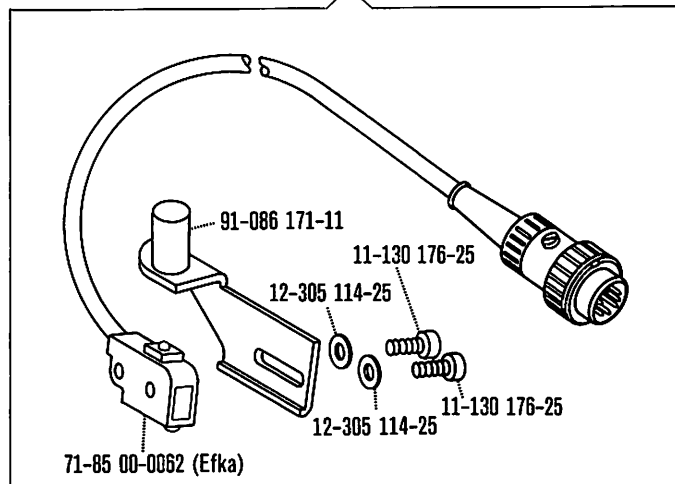

91-091 503-91
NDK 880/..18.002 097

Quick

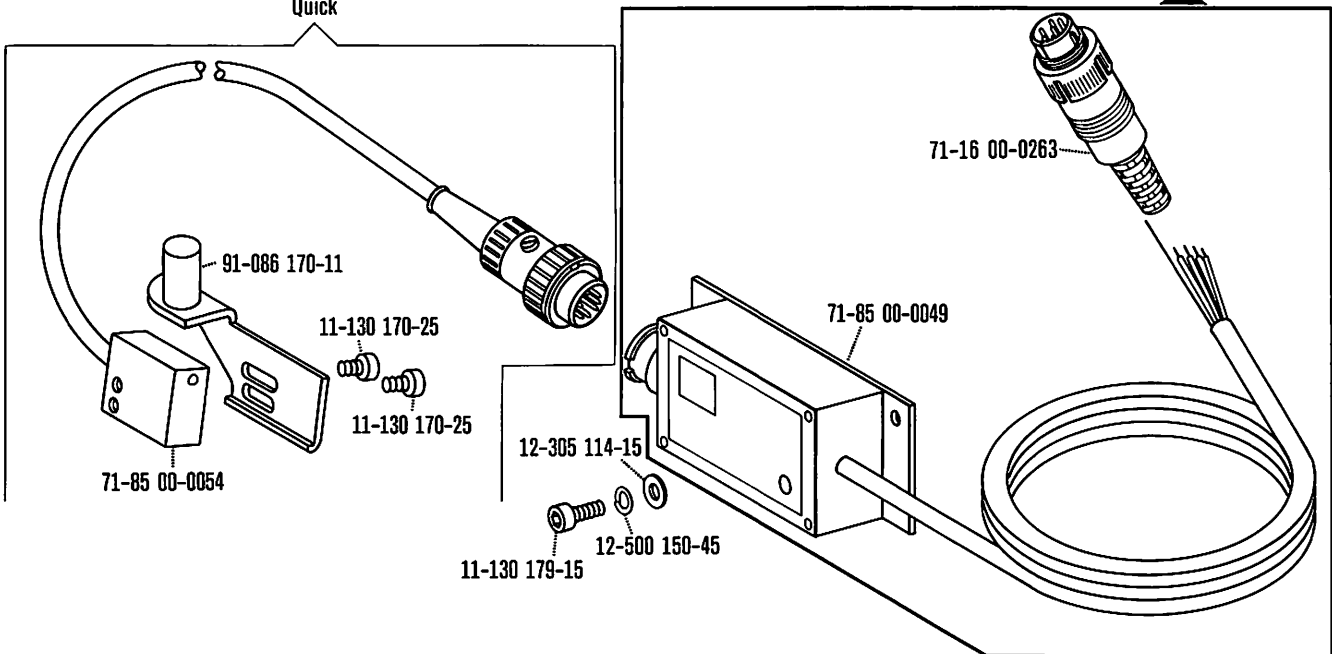

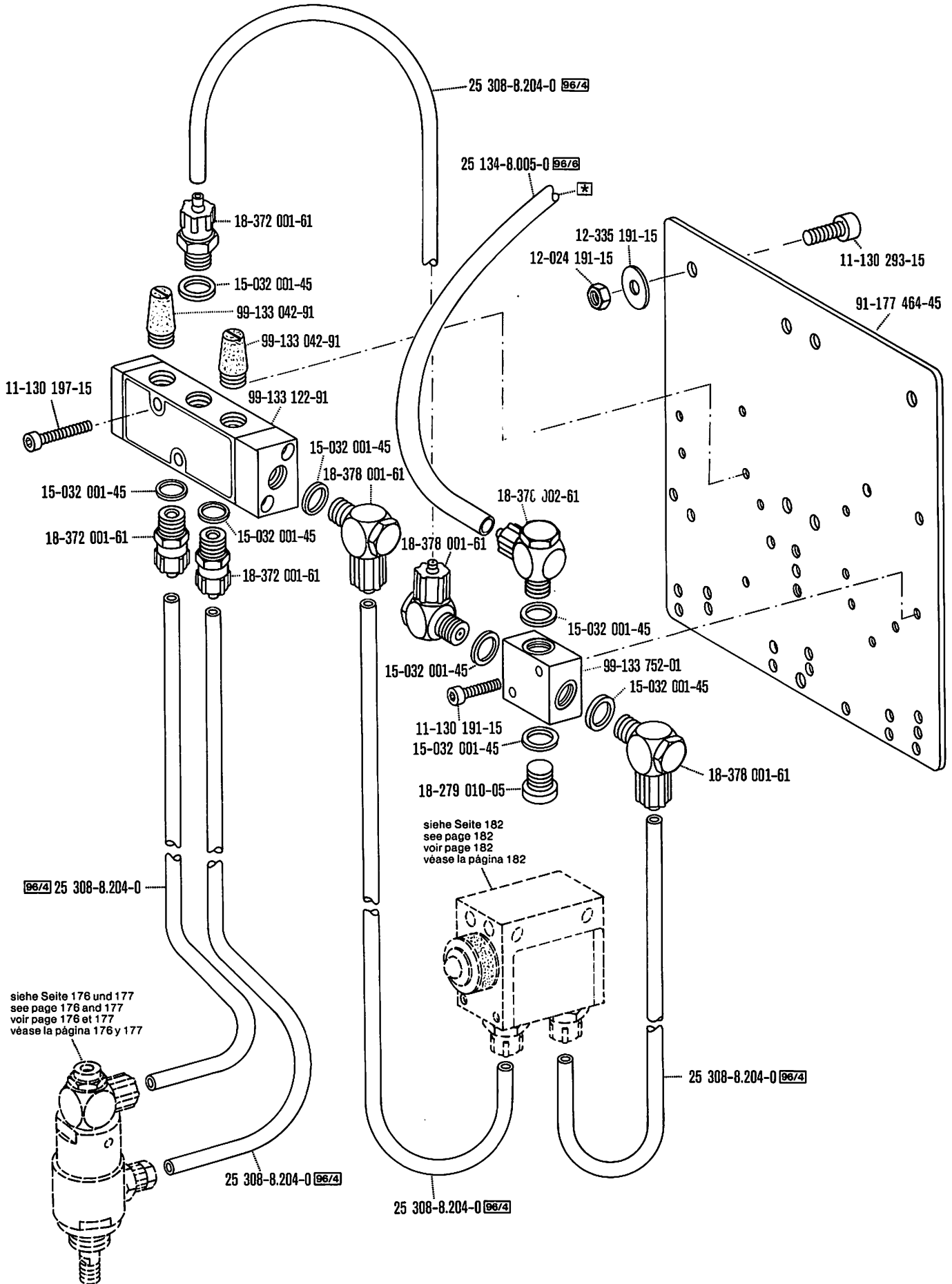

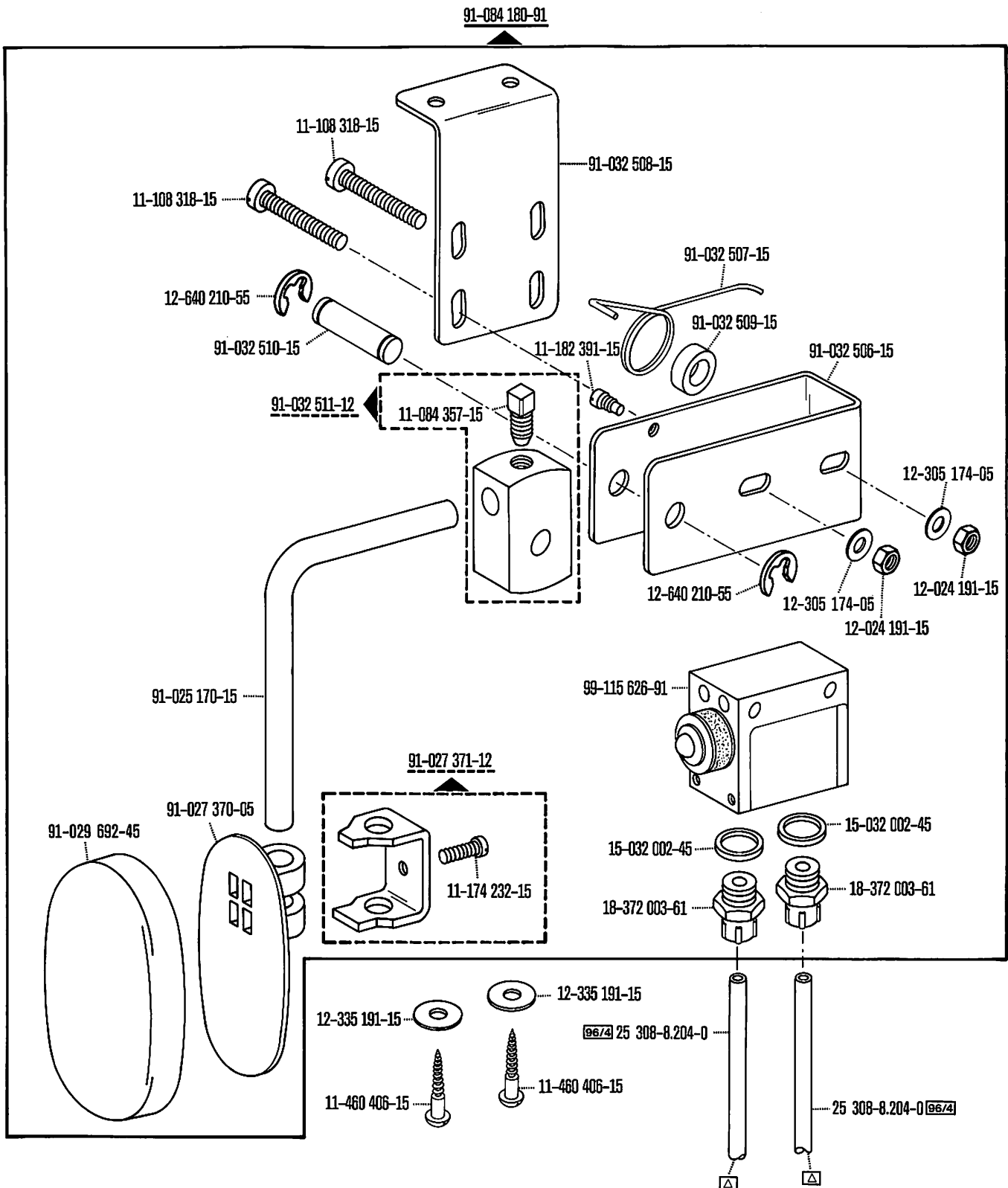

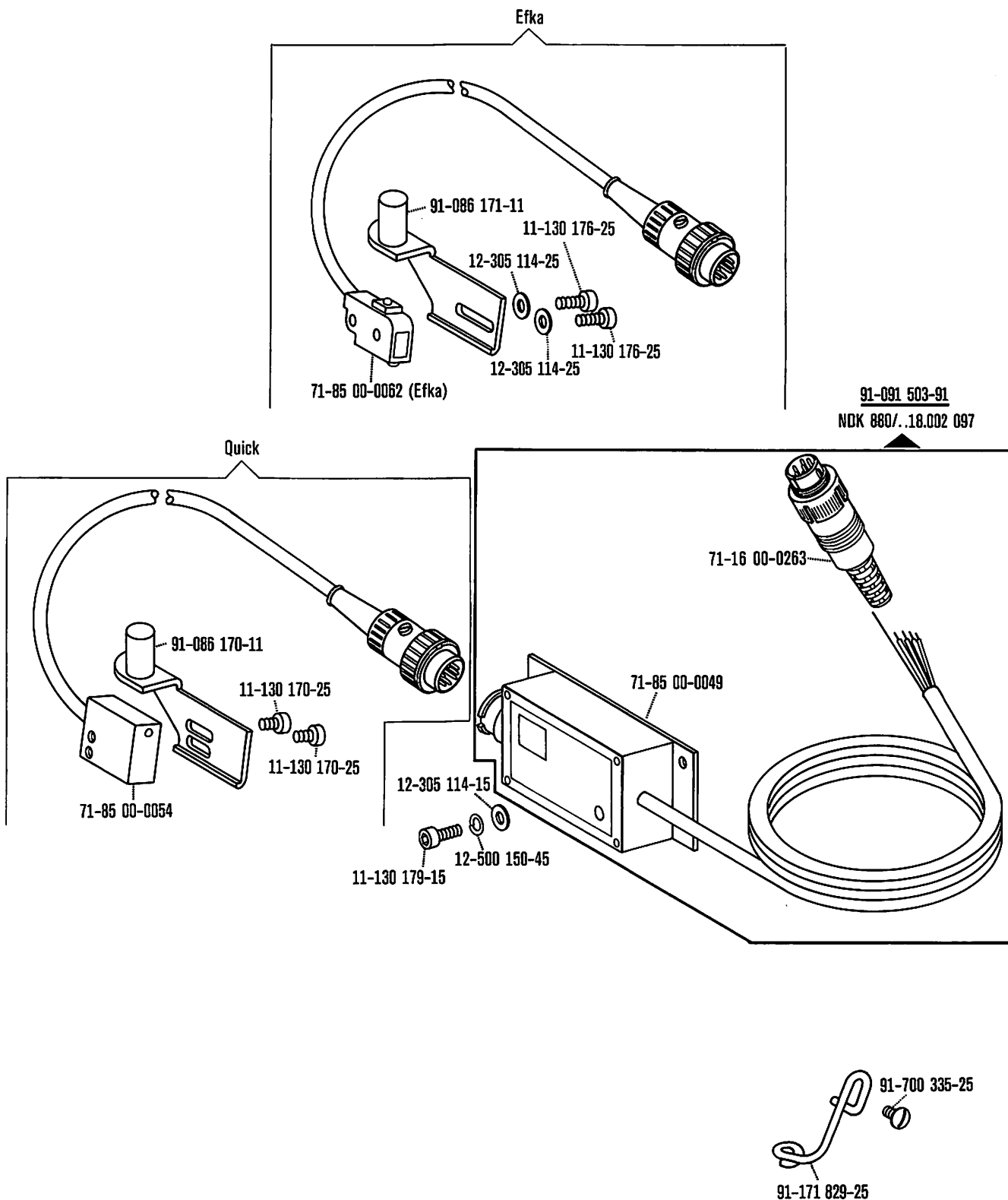

Efka

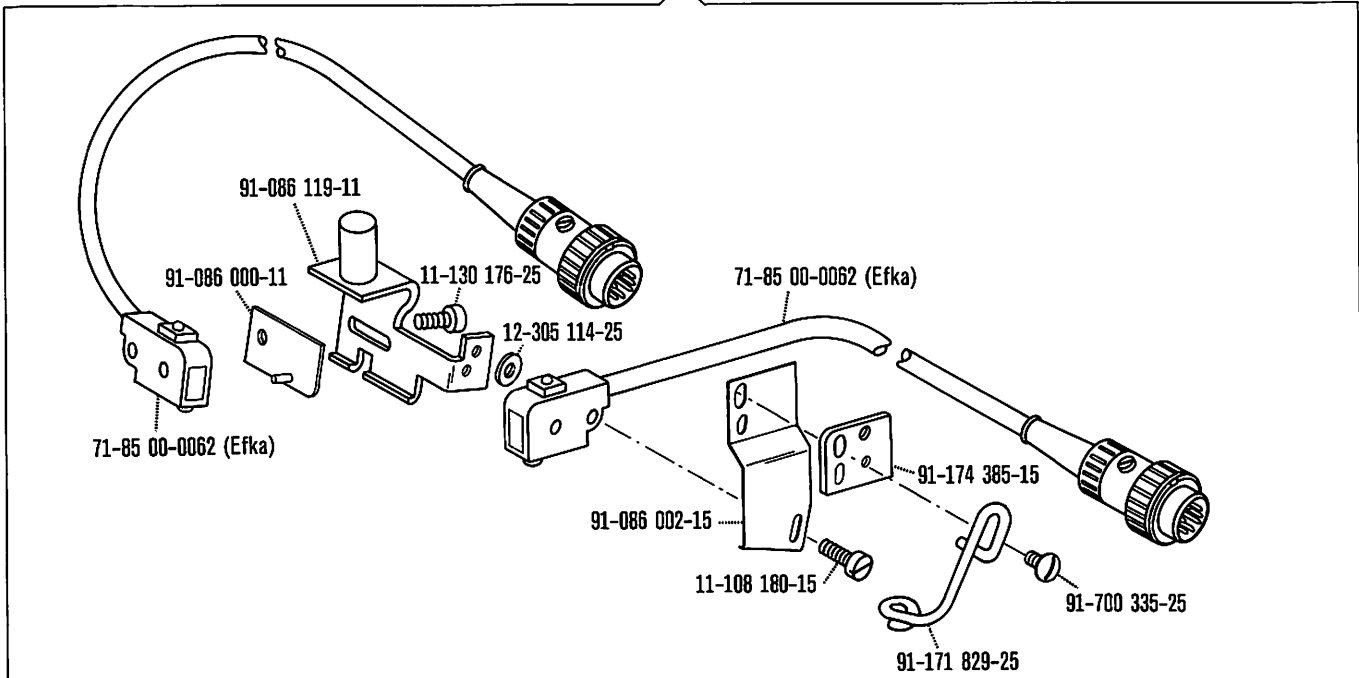

Quick

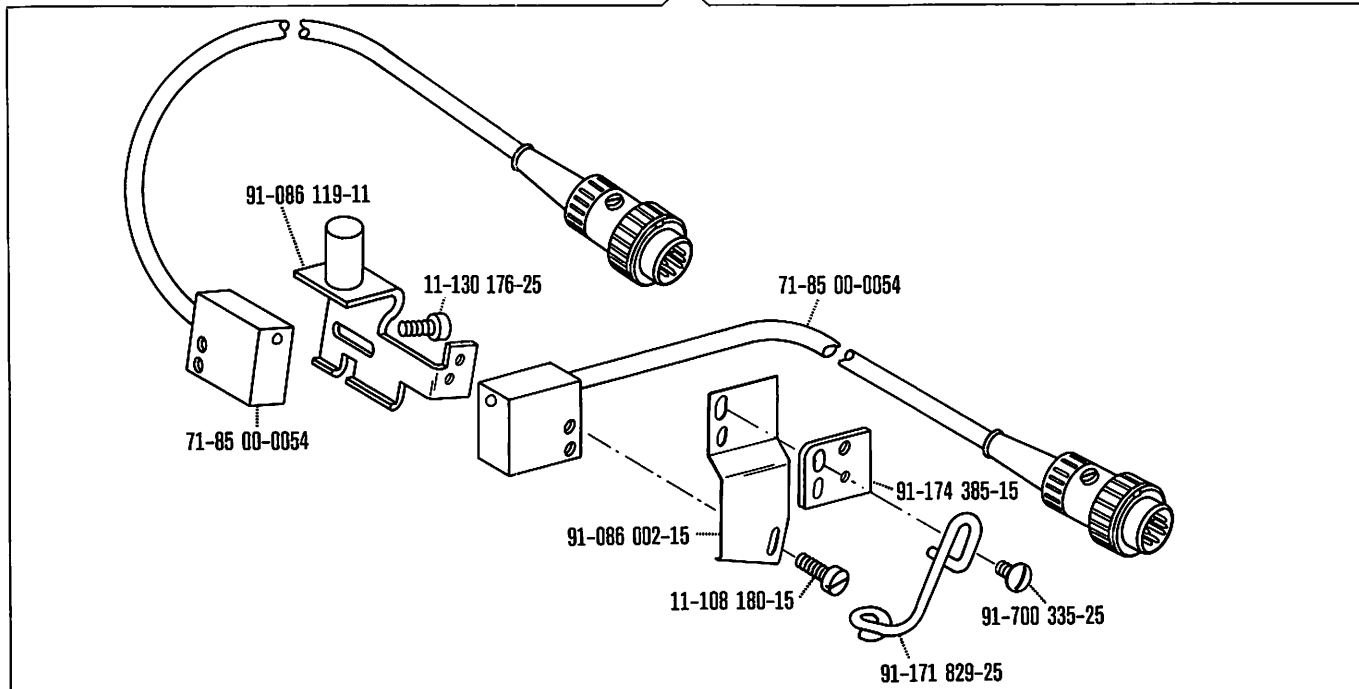

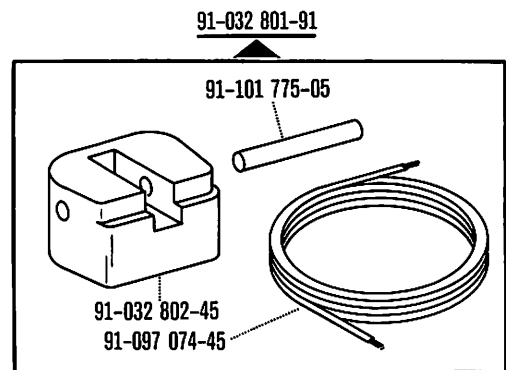
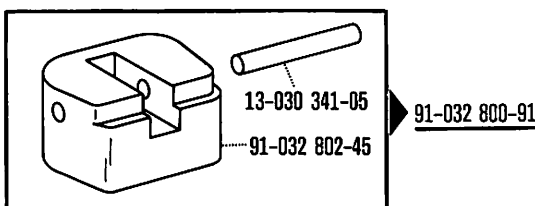
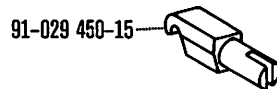
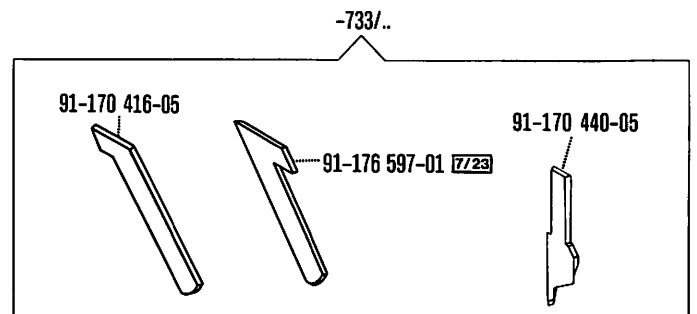
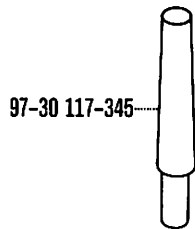
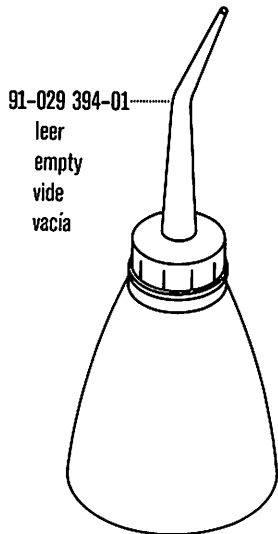
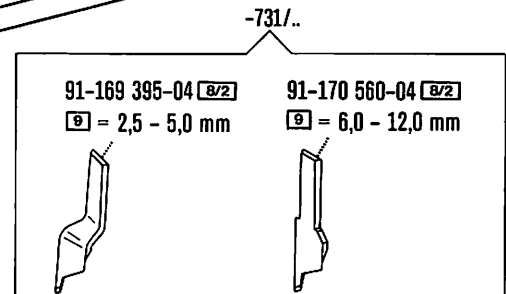
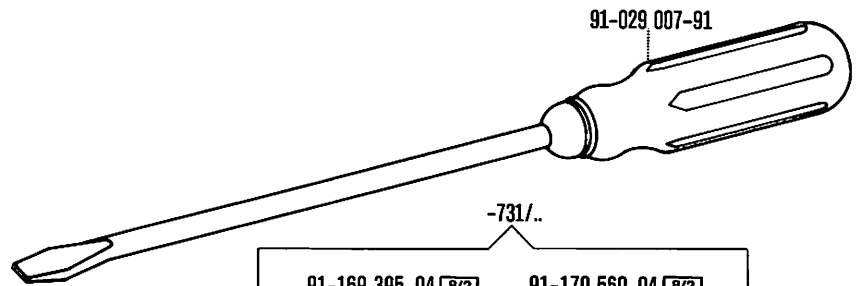
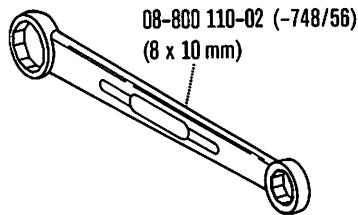
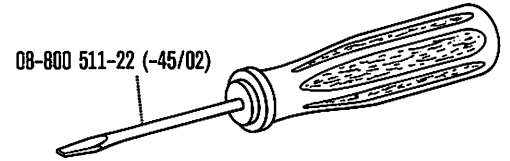
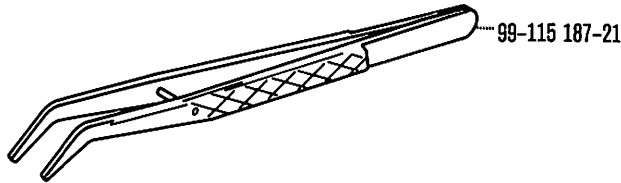
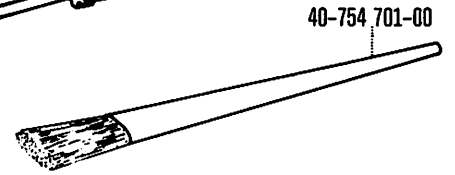
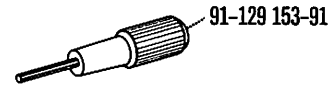

-733/..
 -748/56

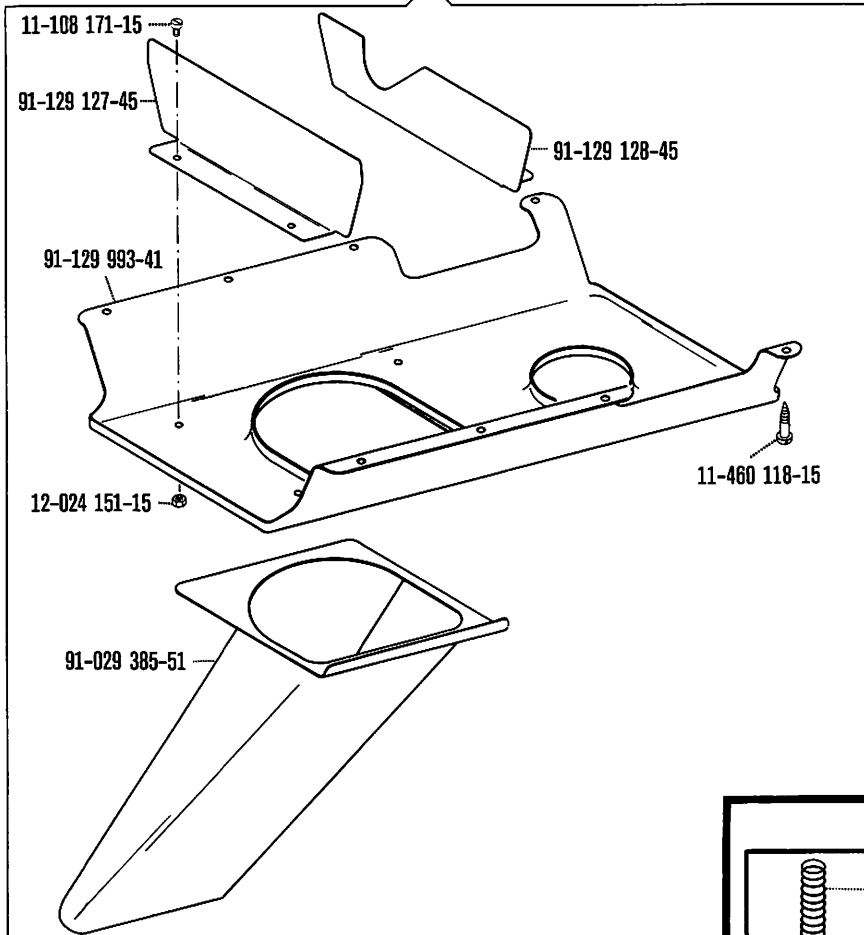

siehe Seite 188
 see page 188
 voir page 188
 véase la página 188

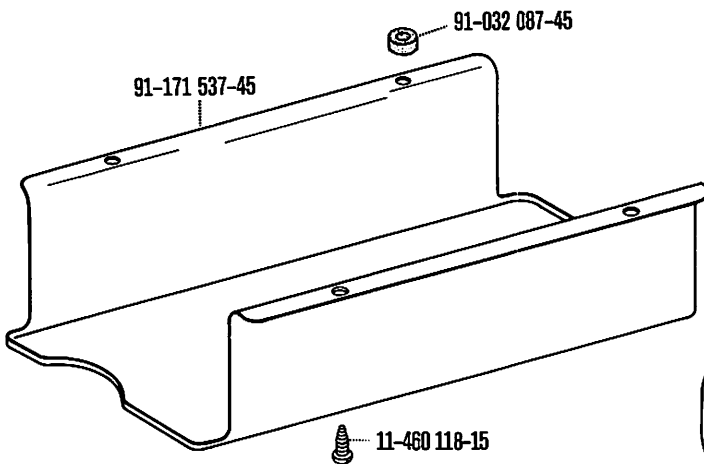
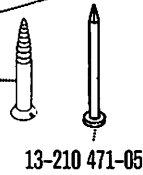
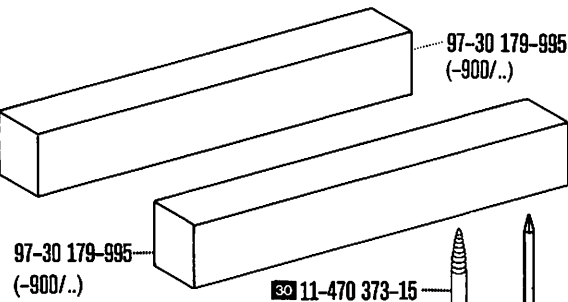
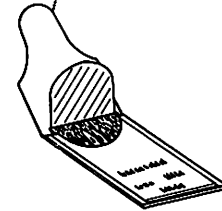

91-171 412-91

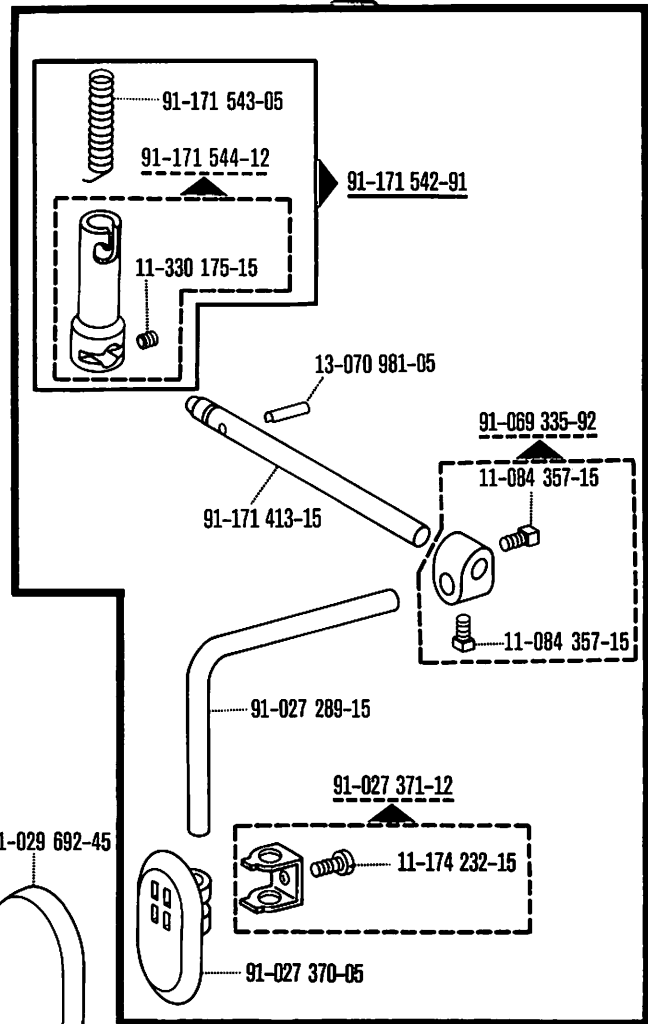

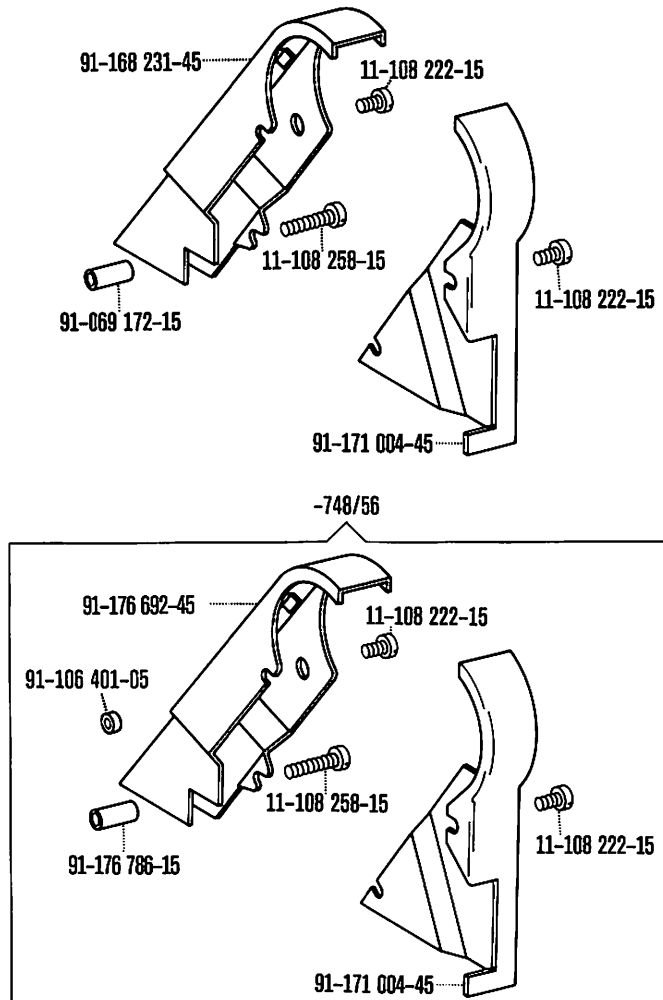

Einstellehren
Adjustment gauges
Calibres
Calibres de ajuste

zur · pour
for · para Pfaff 5483

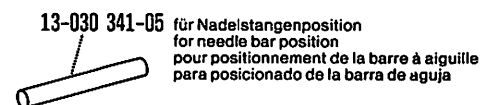
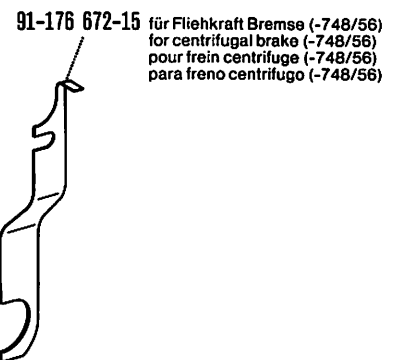
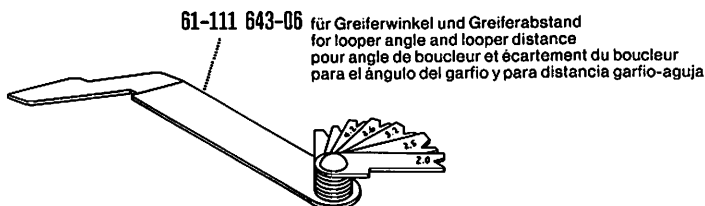

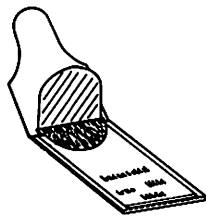

Nadelsystem-Tabelle
Table of Needle system
Tableau des système d'aiguille
Tabla de sistema de agujas

Unterklasse Subclass Sous-classe Subclase	Nadelsystem <input type="checkbox"/> Needle system <input type="checkbox"/> Système d'aiguille <input type="checkbox"/> Sistema de agujas <input type="checkbox"/>	Unterklasse Subclass Sous-classe Subclase	Nadelsystem <input type="checkbox"/> Needle system <input type="checkbox"/> Système d'aiguille <input type="checkbox"/> Sistema de agujas <input type="checkbox"/>
-814/01-6/01	4463-35	H-814/01-6/10-911/..	5463-35
-814/01-6/02	4463-35	H-814/01-6/01-900/...-911/..	5463-35
-814/01-6/10	4463-35	H-814/01-6/02-900/...-911/..	5463-35
-814/01-17/31	4463-35	H-814/01-6/10-900/...-911/..	5463-35
-814/01-19/01	4463-35	H-814/01-6/12-900/...-911/..	5463-35
-814/01-39/31	4463-35	HO-814/01-749/01-6/01	4463 KK
-814/01-57/01	4463-35	HO-814/01-944/01	4463 KK
-814/01-58/01	4463-35	HO-814/02-45/02	4463-8 FLFR
-814/01-69/01	4463-35	HO-814/02-45/02-900/71	4463-8 FLFR
-814/01-82/12	4463-35	-814/06-61/05	4463-35
-814/01-309/02	4463-35	-814/06-94/01	4463-35
-814/01-6/01-900/..	4463-35	-814/06-95/03	4463-35
-814/01-6/02-900/..	4463-35	-818/55-6/01	4463-35
-814/01-6/10-900/..	4463-35	-818/55-65/01	4463-35
-814/01-19/01-900/..	4463-35	-818/56-65/01	4463-35
-814/01-6/01-960/..	4463-35	-818/56-65/01-960/11	4463-35
-814/01-6/02-960/..	4463-35		
-814/01-6/10-960/..	4463-35		
-814/01-57/01-960/..	4463-35		
-814/01-58/01-960/..	4463-35		
-814/01-731/11-6/01	4463-35		
-814/01-733/11-39/31	4463-35		
-814/01-748/58-6/01	4463-35		
-814/01-944/01	4463-35		
R-814/01-6/02	4463 KK		
R-814/01-6/02-960/10-925/03	4463 KK		
R-814/01-6/02-960/..	4463 KK		
H-814/01-704/02-748/56-6/01-960/11	Uy 128 GAS		
H-814-01-6/01-911/..	5463-35		
H-814/01-6/02-911/..	5463-35		

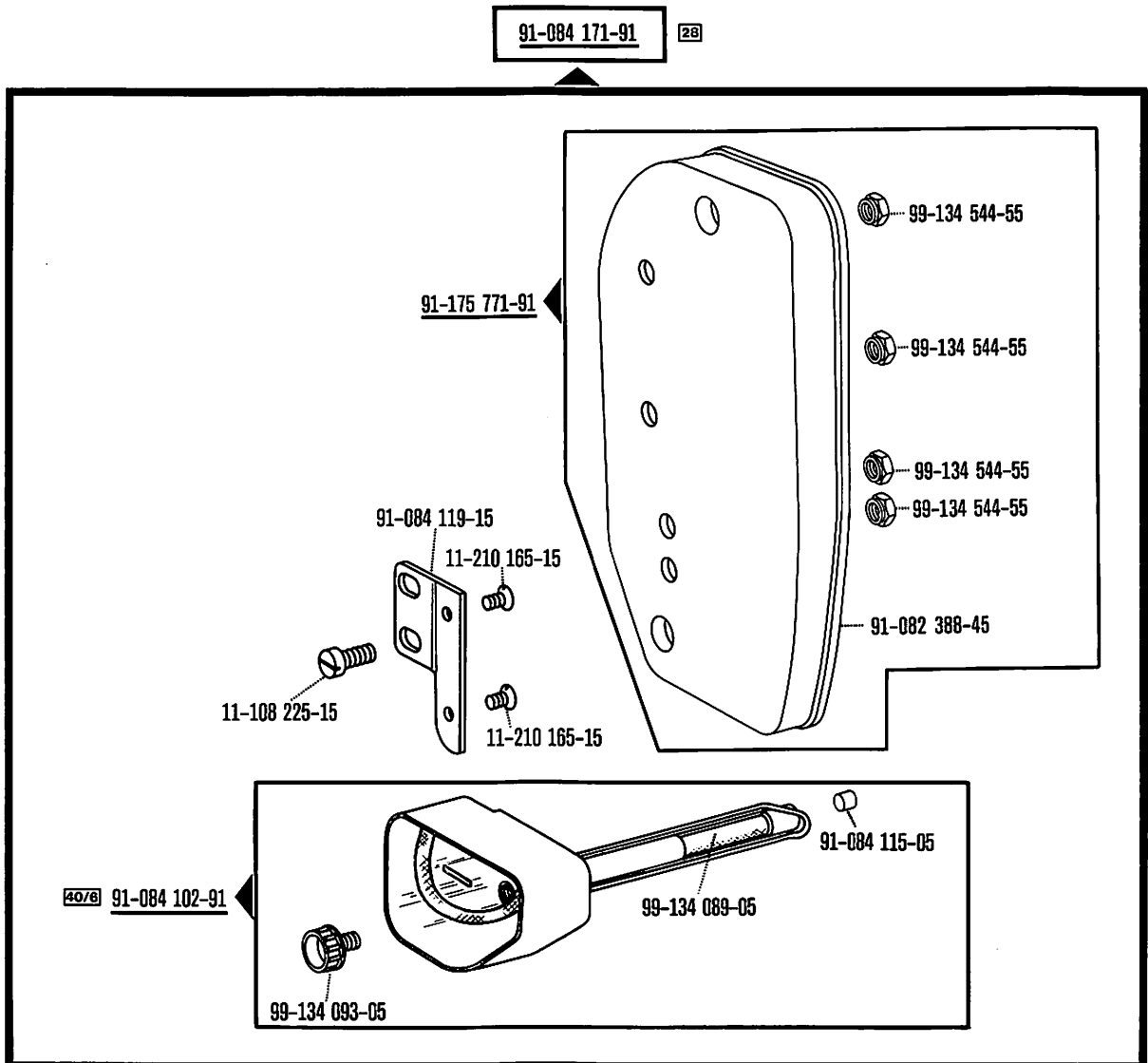

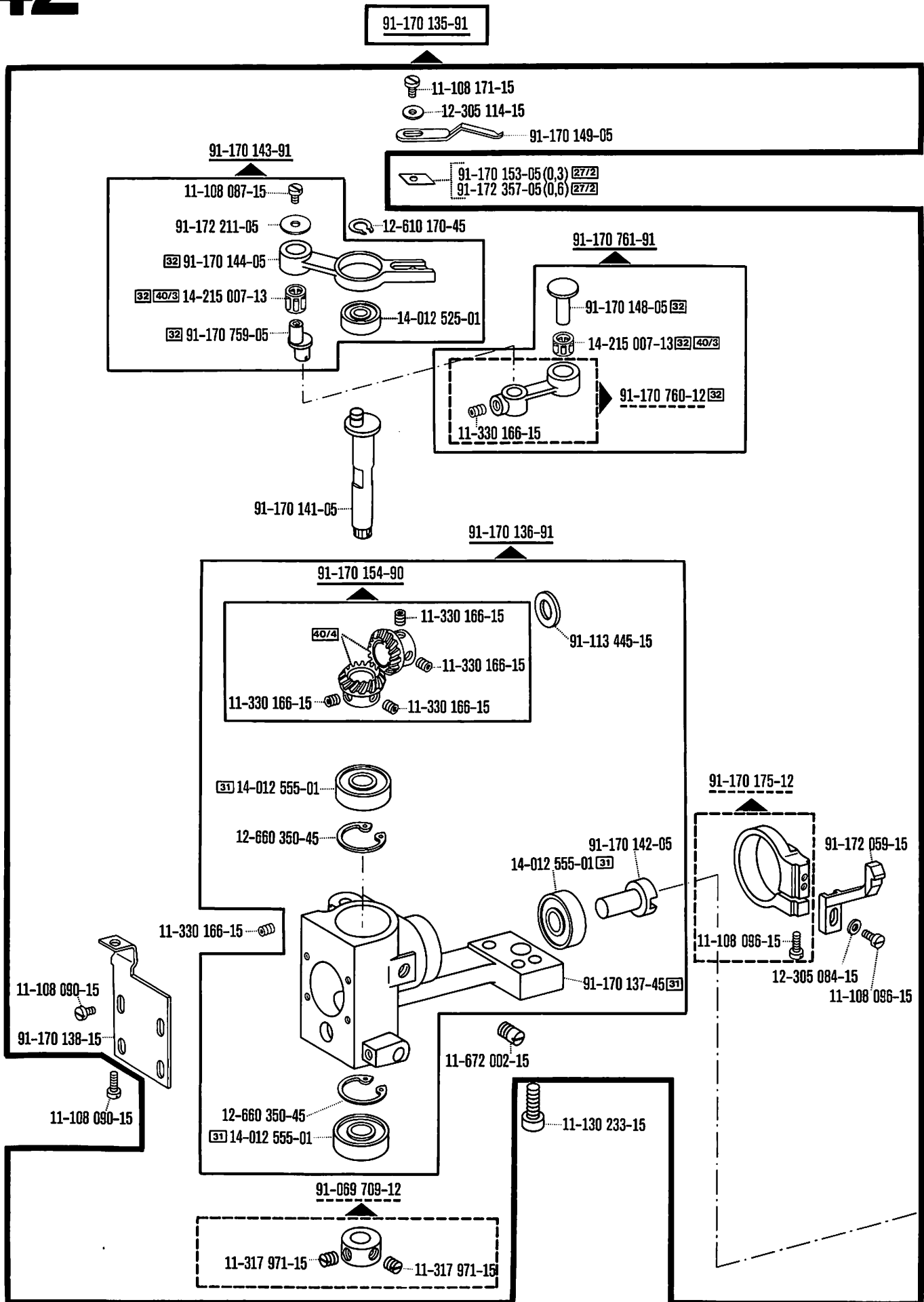

Rückwärtsnäh-Einrichtung
Reverse sewing mechanism
Marche arrière

zur · pour
 for · para **Pfaff 5483 H -911/..**

9.85

42

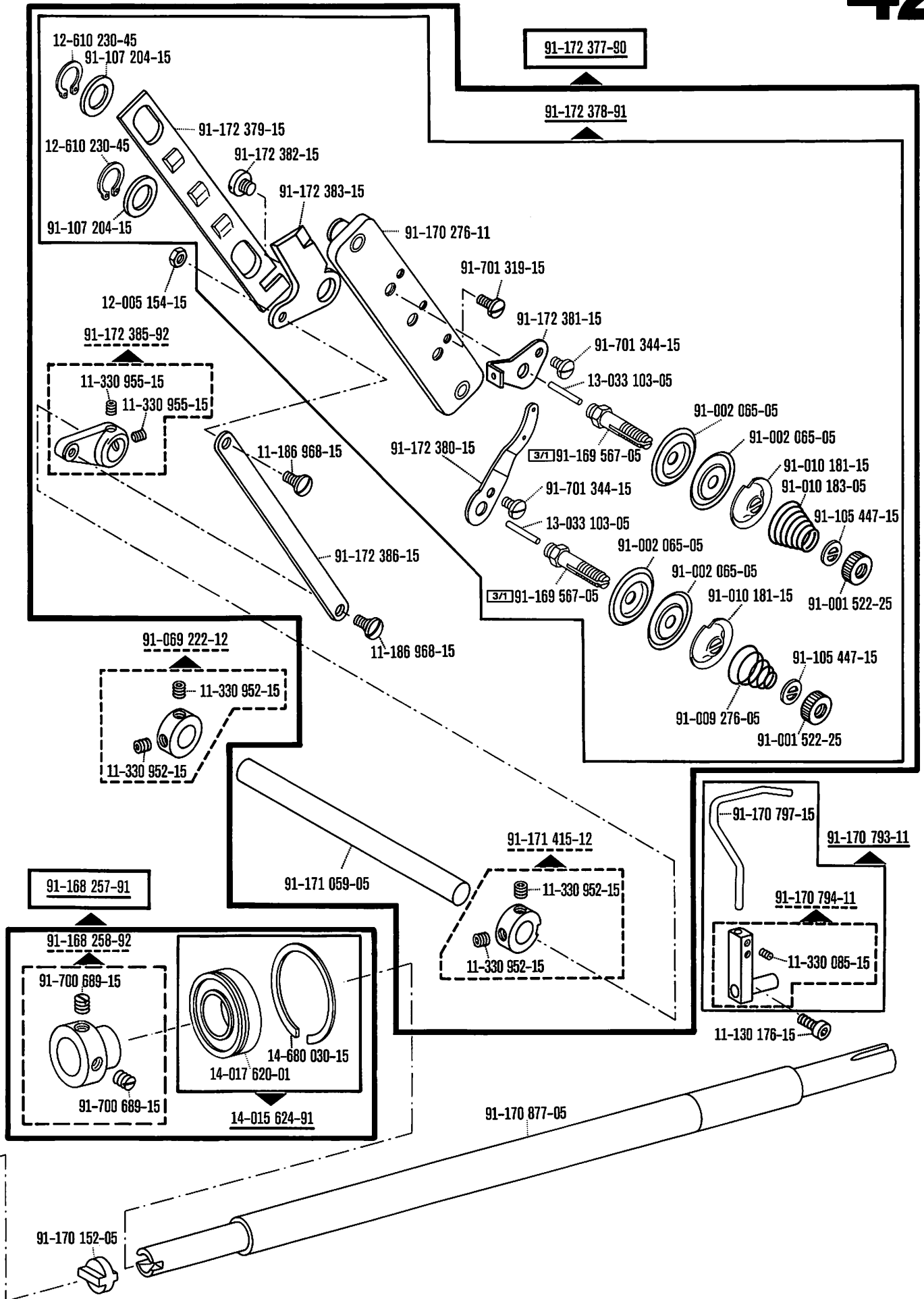

43

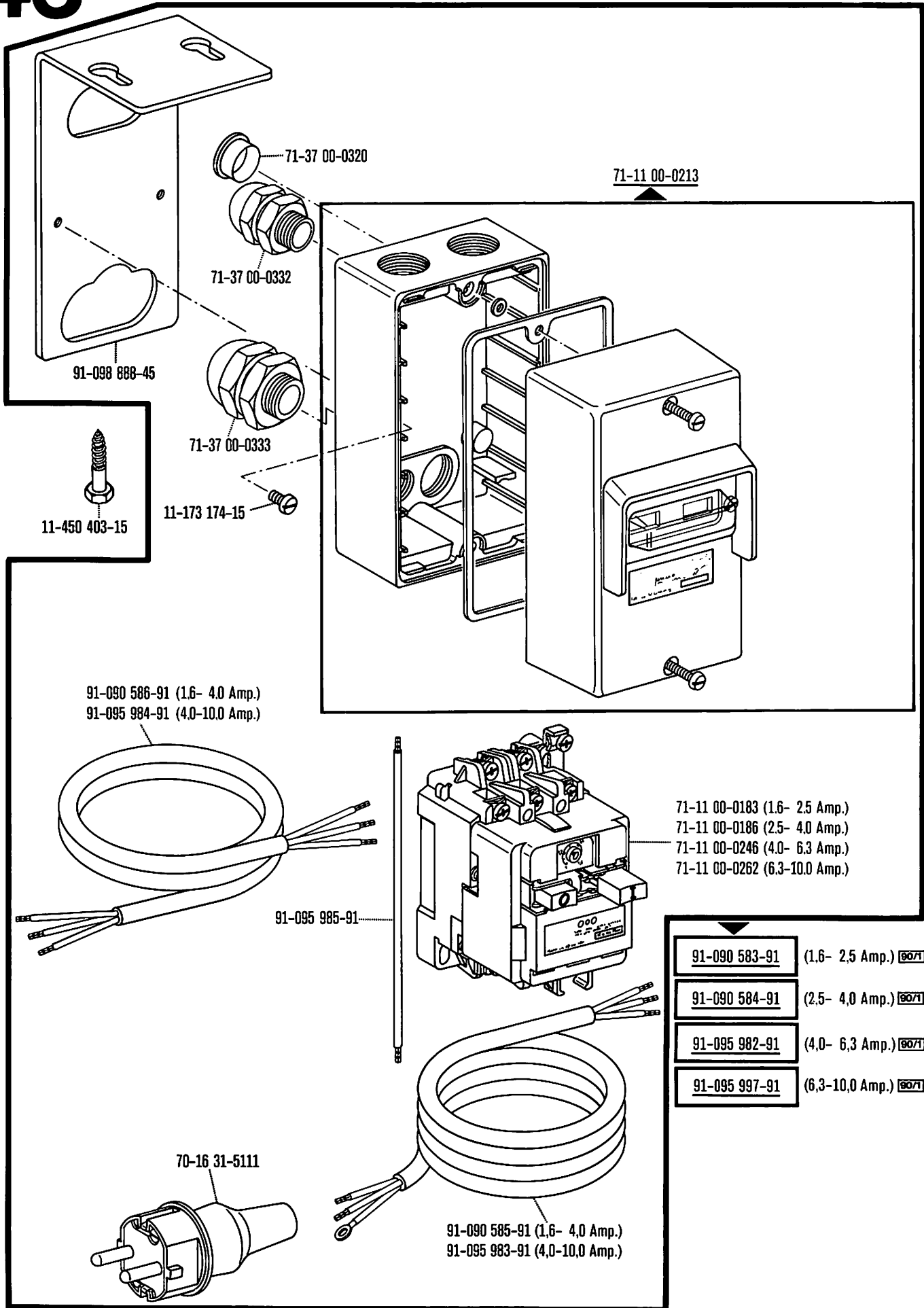

**Motoranschlussatz
Motor connection kit**

**Jeu de pièces à raccorder le moteur
Juego de piezas para conexión del motor**

(Ausrüstung mit Motorschutzschalter)
(equipment with motor overload trip)
(avec contacteur-disjoncteur)
(con interruptor de seguridad)

zur · pour
for · para **Pfaff 5483**

9.85

43

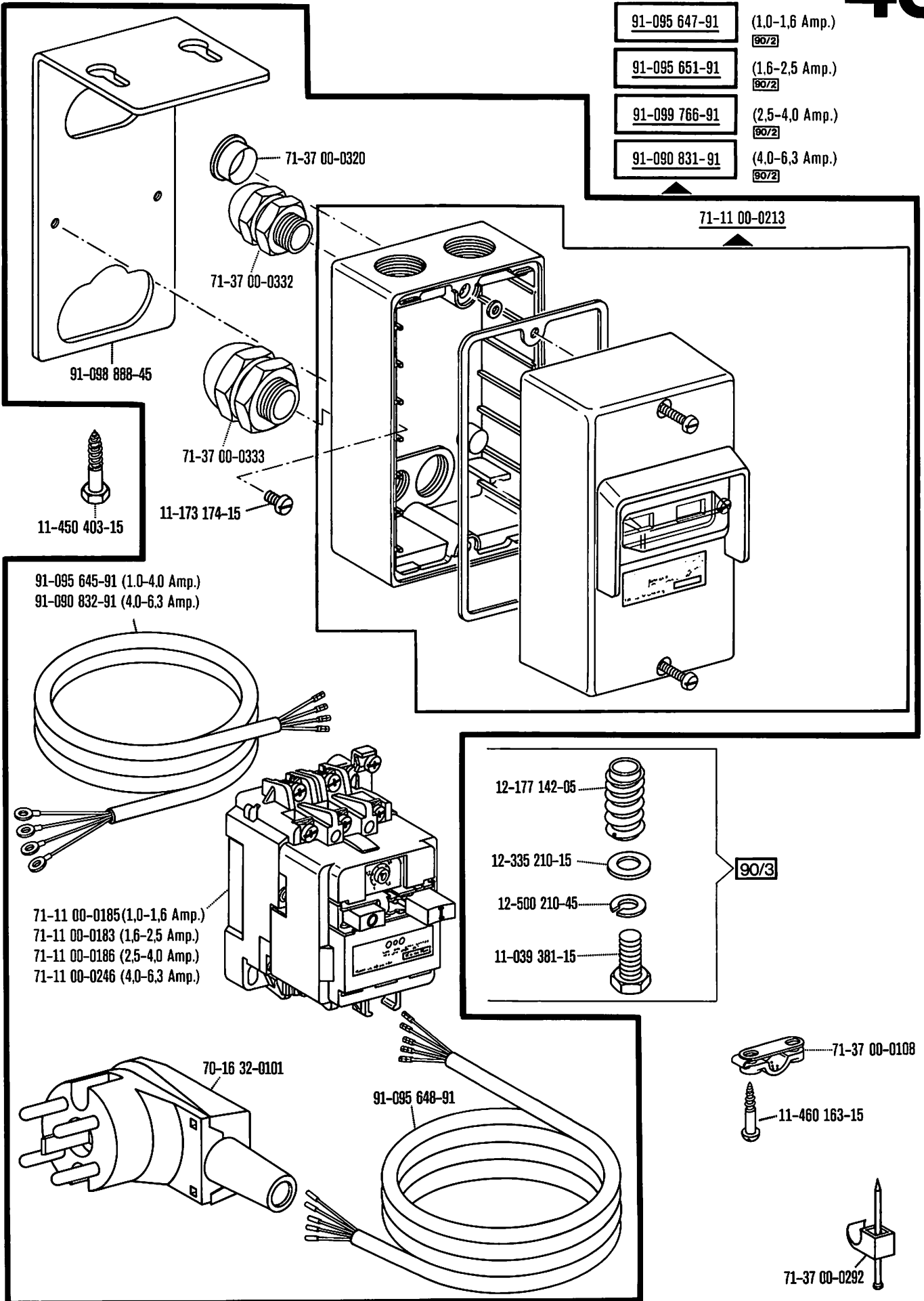

91-096 178-91 

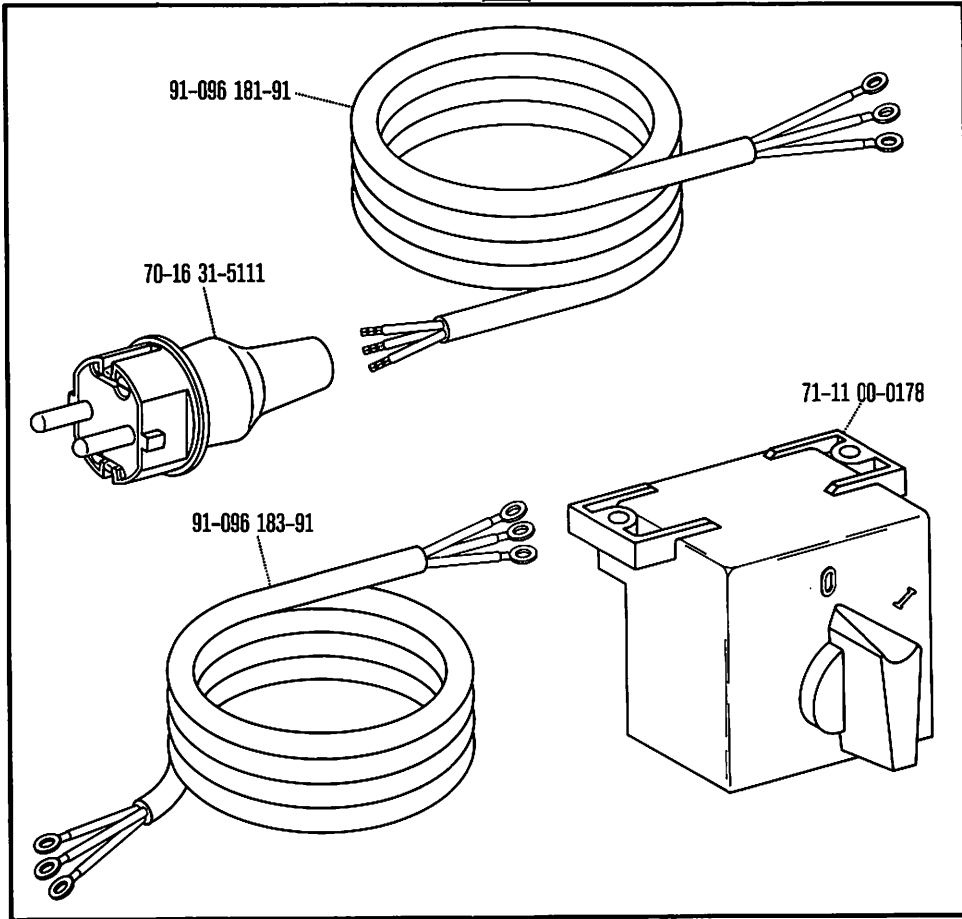

91-095 103-91 

71-37 00-0108



11-460 163-15

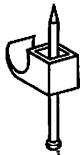

71-37 00-0292

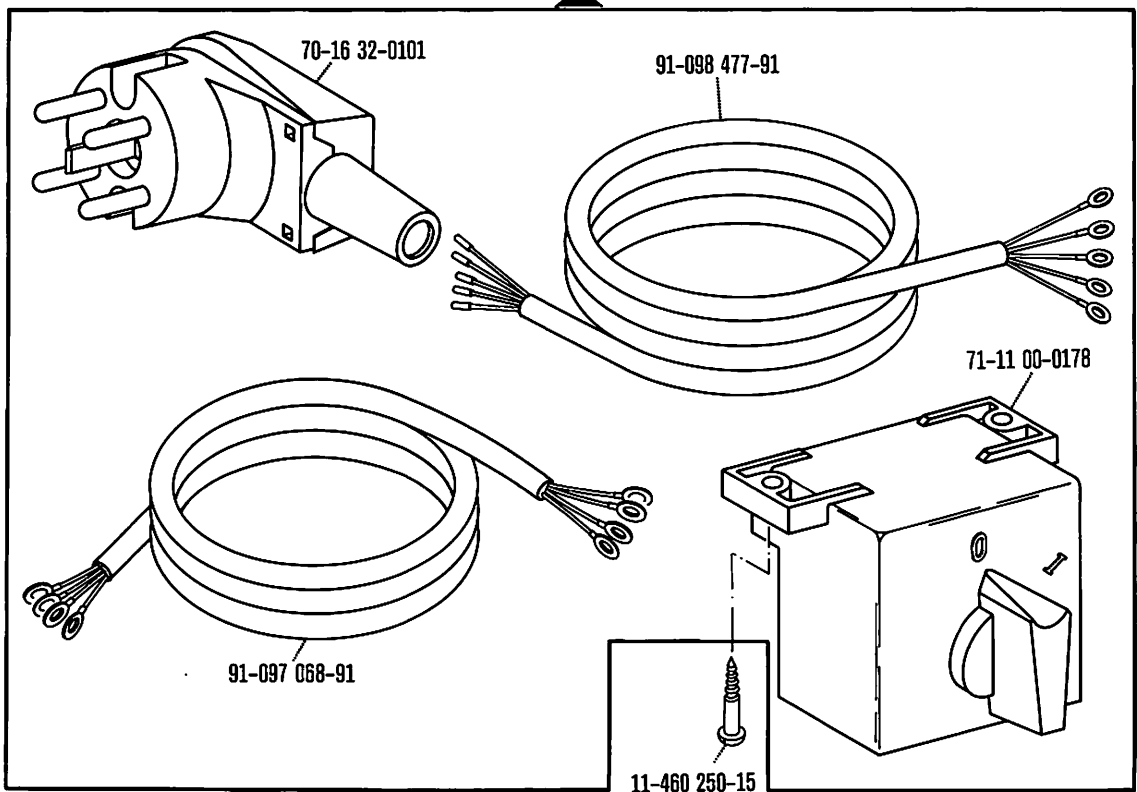

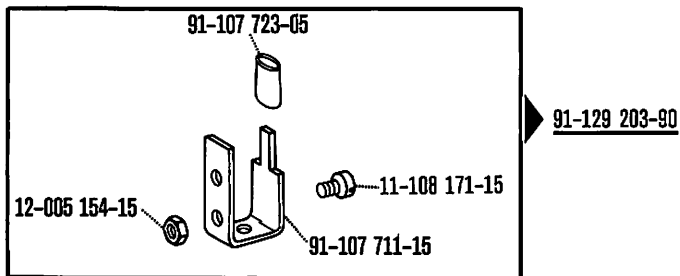
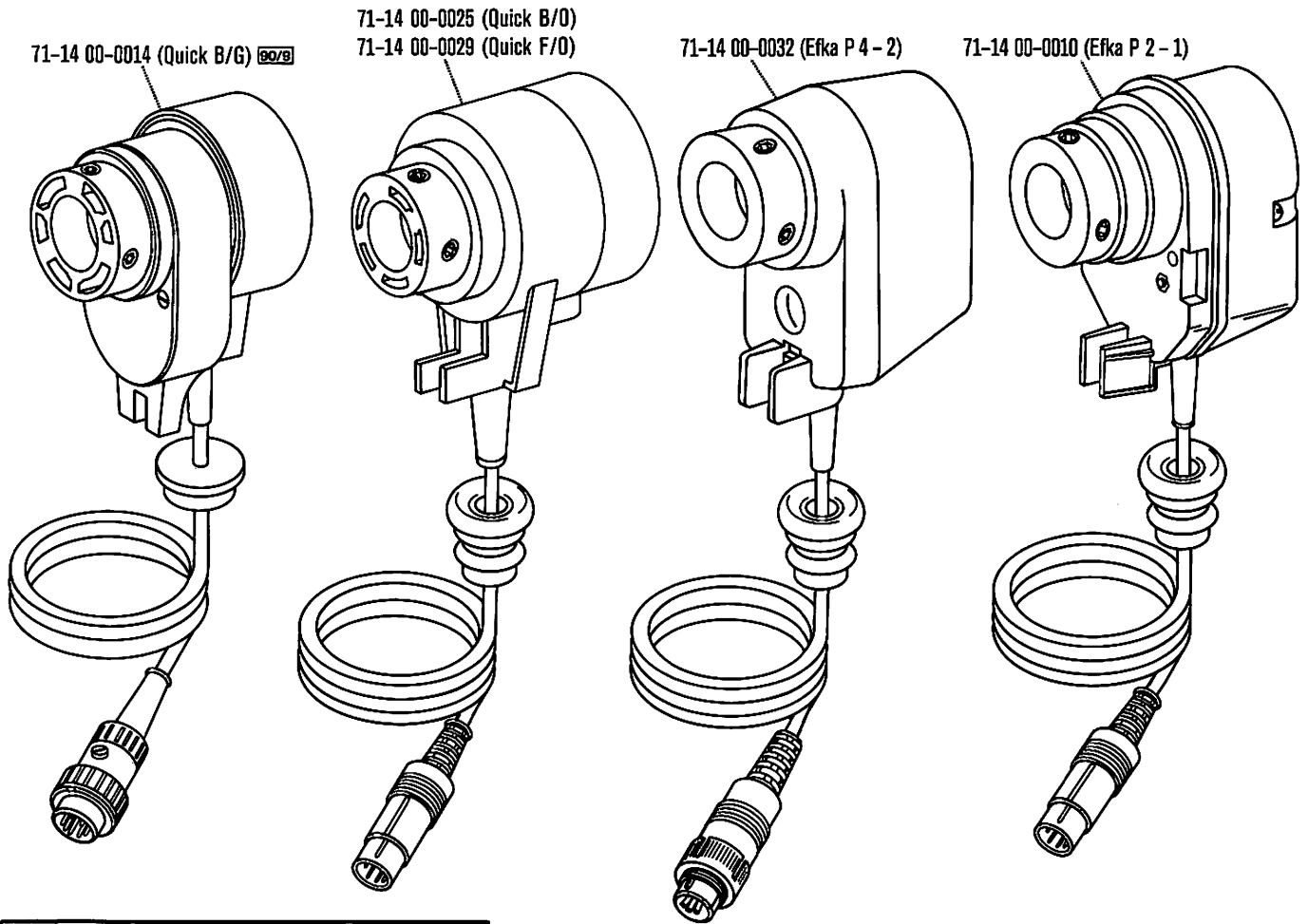



Keilriemenscheiben-Tabelle

Table of V-belt pulleys

Tableau des poulies à gorge en V

Tabla de poleas para correas en „V”

Nähgeschwindigkeit max. Stiche/min Maximum sewing speed in s.p.m. Nombre de points max./mn Número máx. de puntadas por minuto	Motordrehzahl U/min Motor speed in r.p.m. Régime moteur en tours/mn Régimen del motor en r.p.m.	Frequenz Frequency Fréquence Frecuencia	Handrad-Durchmesser ¹⁾ in mm Balance wheel diameter ¹⁾ in mm Diamètre du volant ¹⁾ en mm Diámetro del volante ¹⁾ en mm	Keilriemenscheiben-Durchmesser ¹⁾ in mm V-belt pulley diameter ¹⁾ in mm Diamètre de la poulie à gorge ¹⁾ en mm Diámetro de la polea para correa en „V” ¹⁾ en mm	Teilenummer der Keilriemenscheibe Part number of V-belt pulley Numéro de pièce des poulies à gorge en V No de las piezas de poleas para correas en „V”
7000	2800	50 Hz	65	160	16-437 906-55
7000	3400	60 Hz	65	132	16-437 901-55
6000	2800	50 Hz	65	140	16-437 140-55
6000	3400	60 Hz	65	118	16-437 120-55
5500	2800	50 Hz	65	132	16-437 901-55
5500	3400	60 Hz	65	106	16-437 100-55
5000	2800	50 Hz	65	118	16-437 120-55
5000	3400	60 Hz	65	95	16-437 080-55
4500	2800	50 Hz	65	106	16-437 100-55
4500	3400	60 Hz	65	85	16-437 060-55
4200	2800	50 Hz	65	100	16-437 090-55
4200	3400	60 Hz	65	80	16-437 050-55
3600	2800	50 Hz	65	85	16-437 060-55
3600	3400	60 Hz	65	71	16-437 030-55
1400	1400	50 Hz	65	67	16-437 020-55
1400	1700	60 Hz	65	50	16-437 908-55

No.	Seite Page Página	No.	Seite Page Página	No.	Seite Page Página	No.	Seite Page Página
08-800 110-02	101, 185	11-108 099-25	162, 174	11-108 213-15	152, 155	11-130 176-25	180, 183, 184
08-800 511-22	185	11-108 102-15	54, 56, 128, 134, 136, 138	11-108 222-15	33, 34, 76, 102, 187	11-130 179-15	31, 180, 183
08-880 137-00	187	11-108 108-15	174	11-108 225-15	20, 21, 30, 32, 33, 34, 36, 37, 42, 50, 62, 63, 64, 65, 67, 69, 71, 76, 82, 83, 84, 85, 89, 92, 93, 94, 95, 105, 112, 131, 148, 173, 174, 189	11-130 191-15	55, 57, 87, 97, 116a, 117, 119, 123, 126, 129, 135, 137, 139, 142, 143, 153, 155, 158, 160, 163, 178, 179, 181
11-022 293-15	144	11-108 108-25	152, 178	11-108 228-15	20, 61, 68, 80, 83, 85, 90, 93, 95, 88, 105, 109, 112, 116, 186, 190, 195	11-130 197-15	103, 116, 178, 181
11-032 312-15	131	11-108 117-15	152	11-108 234-15	115	11-130 203-15	87, 97
11-032 315-15	131	11-108 132-15	83, 85, 93, 95	11-108 237-15	35	11-130 224-15	18, 22, 33, 36, 39, 44, 54, 56, 58, 62, 64, 66, 70, 71, 101, 105, 108, 111, 112, 114, 115, 121, 125, 128, 134, 136, 138, 149
11-039 096-15	83, 85, 93, 95	11-108 135-15	70, 81, 91, 149	11-108 240-15	104, 110, 115, 131	11-130 224-25	176
11-039 171-15	83, 85, 93, 95	11-108 168-15	17, 19, 38, 59, 151	11-108 250-15	68	11-130 227-15	54, 56, 127, 134, 136, 140, 150, 151, 156, 176, 177
11-039 177-15	80, 90	11-108 171-15	17, 18, 29, 48, 62, 63, 88, 105, 109, 112, 116, 186, 190, 195	11-108 258-15	102, 187	11-130 233-15	30, 31, 33, 37, 43, 48, 49, 58, 62, 65, 67, 69, 70, 78, 82, 84, 92, 94, 104, 110, 114, 149, 156, 176, 177, 190
11-039 198-15	60	11-108 173-05	53	11-108 285-15	50, 121	11-130 239-15	22, 23, 40, 41, 73, 91, 126, 142, 143, 150, 151, 158
11-039 288-15	51	11-108 174-15	17, 20, 28, 29, 31, 32, 37, 42, 43, 44, 45, 46, 49, 50, 52, 55, 57, 58, 59, 61, 65, 67, 69, 70, 71, 75, 77, 78, 81, 82, 84, 88, 89, 91, 92, 94, 101, 104, 110, 114, 116, 116a, 116b, 117, 119, 123, 129, 130, 132, 133, 135, 137, 139, 141, 142, 149, 159, 160, 163, 171, 179	11-108 288-15	51, 85, 95	11-130 239-25	177
11-039 291-15	103, 120	11-108 174-25	20, 36, 72, 161, 173	11-108 294-15	105, 112, 115, 144	11-130 245-15	116, 131
11-039 363-15	52, 106, 107, 161, 173	11-108 177-15	16, 17, 18, 30, 31, 35, 43, 49, 59, 62, 66, 67, 69, 75, 80, 90, 150, 166, 177	11-108 306-15	131	11-130 254-15	22, 23, 36, 40, 41, 58, 65, 66, 73, 170, 175, 176, 177
11-039 381-15	193	11-108 180-15	17, 22, 23, 29, 30, 35, 38, 66, 68, 73, 98, 150, 184	11-108 318-15	86, 96, 154, 164, 182	11-130 257-15	169
11-084 357-15	54, 86, 96, 134, 154, 164 182, 186	11-108 185-15	126	11-108 846-15	19, 28	11-130 281-15	116
11-105 113-15	44, 45, 46, 130, 132, 133 141, 159, 171, 172	11-108 186-15	43, 75, 126, 131	11-108 849-15	108, 111, 114	11-130 284-15	98
11-105 179-15	105, 112	11-108 186-15	43, 75, 126, 131	11-108 852-15	79, 111, 116b	11-130 287-15	31, 100, 103, 126, 142, 143, 158, 166
11-106 947-15	98	11-108 189-15	142	11-108 855-15	81, 91		
11-106 958-15	131			11-130 092-15	161		
11-108 021-15	131			11-130 170-15	76		
11-108 084-15	28, 50, 59, 68			11-130 170-25	180, 183		
11-108 087-15	48, 64, 76, 104, 110, 114, 116, 148, 152, 178, 190			11-130 173-15	31, 72, 77, 103, 131		
11-108 087-25	152, 178, 187			11-130 176-15	31, 37, 49, 60, 68, 80, 83, 85, 90, 93, 95, 98, 100, 101, 125, 143, 162, 191		
11-108 090-15	18, 27, 48, 131, 166, 190						
11-108 093-15	17, 59, 103, 149, 171, 176, 177						
11-108 093-25	53						
11-108 096-15	48, 60, 61, 106, 107, 131, 161, 173, 190						
11-108 099-15	44, 45, 46, 130, 132, 133, 141, 159, 171, 172, 176, 177						

No.	Seite Page Pages Página	No.	Seite Page Pages Página	No.	Seite Page Pages Página	No.	Seite Page Pages Página
11-130 293-15	51, 55, 57, 82, 84, 87, 92, 94, 97, 116a, 117, 119, 123, 125, 129, 135, 137, 139, 153, 155, 160, 163, 169, 170, 178, 179, 181	11-174 176-15	31, 37, 43, 39, 48, 58, 61, 65, 67, 69, 77, 78	11-210 210-15	40, 41, 99	11-330 085-15	16, 19, 31, 36, 37, 39, 44, 49, 59, 64, 68, 70, 71, 74, 79, 88, 148, 149, 191
		11-174 224-15	18, 36, 39, 44	11-210 216-15	29, 38		
		11-174 232-15	54, 86, 96, 134, 154, 164, 182, 186	11-210 226-15	166	11-330 166-15	31, 37, 42, 43, 48, 49, 58, 60, 64, 65, 67, 69, 72, 77, 78, 98, 100, 101, 148, 190
11-130 299-15	61, 71, 81, 91, 166	11-174 359-15	35	11-210 259-15	103		
11-130 299-25	177	11-178 166-15	76	11-210 287-15	24		
11-130 305-15	166	11-178 172-15	31, 61, 81, 83, 91, 93	11-225 172-15	18, 167		
11-130 311-15	103, 142, 143, 145, 146, 147	11-178 289-15	24	11-225 232-15	20	11-330 169-15	100
11-130 359-15	144	11-180 094-15	81, 91	11-225 310-15	26	11-330 172-15	98, 151
11-130 377-15	54, 56, 118, 122, 124, 128, 134, 136, 138	11-182 391-15	86, 96, 154, 164, 182	11-225 376-15	26	11-330 175-15	54, 56, 118, 121, 122, 124, 127, 134, 136, 140, 186
11-130 563-15	35, 39, 50, 63, 77, 88	11-186 079-15	105, 112, 115	11-225 379-15	27	11-330 217-15	60, 61, 81, 91, 104, 110, 114, 156
11-130 952-15	22	11-186 934-15	108, 111, 114	11-225 902-15	54, 56, 118, 122, 124, 128, 134, 136, 138	11-330 220-15	18, 20, 80, 83, 85, 93, 95
11-132 172-15	81, 91	11-186 962-05	150, 151	11-250 166-15	98	11-330 952-15	20, 22, 26, 28, 32, 37, 47, 50, 58, 65, 67, 69, 71, 77, 80, 83, 85, 89, 90, 93, 95, 100, 126, 131, 135, 140, 142, 143, 158, 191
11-132 223-15	18	11-186 968-15	47, 191	11-250 193-25	26		
11-135 538-15	35, 39, 50, 63, 77, 88	11-186 971-15	120	11-305 248-15	33, 62		
11-135 544-15	35, 39, 50, 63, 77, 88	11-186 976-15	44, 45, 46, 120, 130, 132, 133, 141, 152, 159, 171, 172	11-305 299-15	25		
11-135 574-15	35, 39, 50, 63, 77, 88	11-207 064-15	120	11-314 169-15	38, 102		
11-173 171-15	98, 100, 103	11-210 038-15	44, 45, 46, 130, 132, 133, 141, 152, 159, 171, 172	11-314 220-15	32, 36, 72	11-330 955-15	33, 34, 47, 76, 191
11-173 171-55	46, 133, 159, 172	11-210 074-15	156	11-314 280-15	61	11-335 088-15	60, 61, 80, 90
11-173 174-15	98, 162, 174, 192, 193	11-210 076-15	17, 42, 176, 177	11-314 946-15	142, 143	11-335 280-15	72, 82, 84, 92, 94
11-173 174-25	182, 174	11-210 081-15	27, 76, 101	11-314 964-15	31, 37, 42, 49, 50, 62, 65, 67, 69, 71, 89, 166, 176, 177	11-335 902-15	24, 26, 27, 28, 60, 77, 102
11-173 177-25	162, 174	11-210 088-15	156	11-317 217-15	16, 75	11-341 088-15	156
11-173 225-15	70	11-210 095-15	156	11-317 949-15	71	11-341 166-15	32, 37, 42, 50, 65, 67, 69, 71, 82, 84, 89, 92, 94
11-174 086-15	72	11-210 165-15	28, 64, 76, 148, 162, 174, 189	11-317 950-15	16, 31, 43, 62, 63, 166, 176, 177	11-341 169-15	77
11-174 089-15	17, 66, 156	11-210 165-25	152, 178	11-317 971-15	48, 190	11-341 217-15	30, 43, 49, 59, 66, 69, 82, 83, 84, 85, 92, 93, 94, 95
11-174 089-25	25	11-210 168-15	61, 76, 80, 90	11-320 086-15	85, 95	11-341 277-15	18, 32
11-174 167-15	18, 78, 89	11-210 169-15	102	11-320 218-15	31, 37, 43, 49, 58, 65, 67, 69, 78	11-341 286-15	131
11-174 170-15	18, 19, 25	11-210 170-15	28, 50	11-320 233-15	60	11-341 901-15	24, 77
11-174 173-15	16, 18, 19, 39, 68, 74, 75, 76, 83, 88, 93, 120	11-210 172-15	176, 177	11-330 082-15	16, 75		
		11-210 186-15	25				

No.	Seite Page Pagas Página	No.	Seite Page Pagas Página	No.	Seite Page Pagas Página	No.	Seite Page Pagas Página
11-341 902-15	24, 26, 27, 28, 33, 34, 58, 60, 72, 76, 78, 89, 101, 102	12-005 215-15	60, 150, 151, 166	12-305 114-25	180, 183, 184	12-500 170-45	162, 174
11-343 854-15	79, 111, 116b	12-024 101-15	108, 111, 114	12-305 144-15	21, 22, 23, 30, 40, 41, 71, 73, 92, 94, 101, 104, 105, 110, 112, 114, 115, 121, 156, 173, 174	12-500 190-15	103
11-410 002-25	161, 173	12-024 121-15	83, 85, 93, 95, 131, 152	12-305 174-05	154, 182	12-500 190-45	51, 105, 112, 115
11-450 403-15	192, 193	12-024 141-15	81, 91	12-305 174-15	61, 81, 86, 91, 96, 100, 116, 144, 164	12-500 210-45	52, 106, 107, 161, 173, 193
11-450 510-15	52	12-024 151-15	60, 63, 88, 104, 110, 114, 151, 186	12-305 224-15	50, 52, 55, 57, 87, 97, 106, 107, 117, 119, 123, 129, 135, 137, 139, 144, 160, 163, 169	12-500 211-45	54, 56, 118, 122, 124, 128, 134, 136, 138
11-460 109-15	45, 46, 133, 159, 172	12-024 151-25	162, 174	12-305 264-15	51	12-501 170-45	126, 142, 143, 158
11-460 118-15	63, 88, 186	12-024 171-15	26, 33, 62, 67, 68, 71, 82, 84, 92, 94, 104, 105, 110, 112, 114, 115	12-315 090-15	81, 91	12-501 190-45	51
11-460 157-15	51, 55, 57, 118, 122, 124, 129, 135, 137, 139, 170, 175	12-024 172-15	26, 104, 110, 114	12-315 170-15	85, 95, 98, 126, 142, 143, 158	12-510 080-45	81, 91
11-460 163-15	193, 194	12-024 191-15	51, 55, 57, 64, 72, 80, 86, 87, 90, 91, 96, 97, 101, 105, 112, 115, 116a, 117, 119, 123, 126, 129, 131, 135, 137, 139, 142, 143, 144, 145, 146, 147, 148, 153, 154, 155, 158, 160, 163, 164, 169, 178, 179, 181, 182, 55, 57, 87, 97, 117, 119, 123, 129, 135, 137, 139, 144, 160, 163, 169	12-335 191-05	120	12-510 111-15	162, 174
11-460 202-15	131	12-024 211-15	98	12-335 191-15	55, 57, 86, 87, 96, 97, 116a, 117, 119, 123, 125, 129, 135, 137, 139, 142, 143, 145, 146, 147, 153, 154, 155, 160, 163, 164, 169, 175, 178, 179, 181, 182	12-510 171-45	144
11-460 211-15	106, 107, 158, 165	12-110 150-15	76, 103	12-341 151-15	51, 68	12-512 110-45	28
11-460 250-15	106, 107, 113, 194	12-160 193-25	68	12-500 090-15	81, 91	12-516 571-05	103
11-460 295-15	162, 174	12-160 213-15	50	12-315 170-15	85, 95, 98, 126, 142, 143, 158	12-517 250-45	60, 61, 80, 90
11-460 304-15	108, 121	12-177 100-05	120	12-335 210-15	161, 173, 193	12-517 270-45	101
11-460 406-15	86, 96, 154, 164, 175, 182	12-177 106-05	51	12-341 151-15	51, 68	12-517 320-45	32
11-460 510-15	144	12-177 142-05	52, 106, 107, 161, 173, 193	12-500 191-05	120	12-518 210-45	19
11-470 373-15	156, 186	12-305 074-25	108, 111, 114	12-500 191-15	55, 57, 86, 87, 96, 97, 116a, 117, 119, 123, 125, 129, 135, 137, 139, 142, 143, 145, 146, 147, 153, 154, 155, 160, 163, 164, 169, 175, 178, 179, 181, 182	12-518 230-45	100
11-550 167-15	103	12-305 084-15	48, 59, 76, 152, 166, 176, 177, 190	12-341 151-15	51, 68	12-610 170-45	48, 70, 105, 112, 115, 149, 190
11-625 407-11	55, 57, 87, 97, 117, 119, 123, 129, 135, 137, 139, 160, 163, 169	12-305 114-15	18, 48, 72, 76, 98, 126, 142, 143, 158, 166, 180, 183, 190	12-500 111-45	19	12-610 190-45	71, 82, 83, 84, 85, 92, 93, 94, 95, 156
11-672 002-15	48, 190	12-500 150-45	180, 183	12-500 121-15	161	12-610 210-45	25, 29, 38, 83, 93
11-672 005-15	29	12-500 151-45	55, 57, 116a, 117, 119, 123, 129, 135, 137, 139, 160, 163, 166, 173, 179	12-500 121-25	18	12-610 230-45	22, 23, 40, 41, 47, 62, 73, 100, 116, 191
11-724 290-55	53	12-500 151-45	55, 57, 116a, 117, 119, 123, 129, 135, 137, 139, 160, 163, 166, 173, 179	12-500 121-45	106, 107, 166, 174	12-610 250-45	26, 62
11-724 300-55	162, 174	12-500 151-45	55, 57, 116a, 117, 119, 123, 129, 135, 137, 139, 160, 163, 166, 173, 179	12-500 150-45	180, 183	12-610 270-45	101
12-005 154-15	47, 109, 191, 195	12-500 151-45	55, 57, 116a, 117, 119, 123, 129, 135, 137, 139, 160, 163, 166, 173, 179	12-500 150-45	180, 183	12-610 280-45	102
12-005 171-15	76	12-500 151-45	55, 57, 116a, 117, 119, 123, 129, 135, 137, 139, 160, 163, 166, 173, 179	12-500 150-45	180, 183	12-610 330-45	102
12-005 175-15	30, 43, 49, 59, 66, 69, 75, 156	12-500 151-45	55, 57, 116a, 117, 119, 123, 129, 135, 137, 139, 160, 163, 166, 173, 179	12-500 150-45	180, 183	12-624 310-45	33
12-005 195-15	54, 56, 85, 95, 125, 128, 131, 134, 136, 138, 176, 177	12-500 151-45	55, 57, 116a, 117, 119, 123, 129, 135, 137, 139, 160, 163, 166, 173, 179	12-500 150-45	180, 183	12-640 070-55	64, 148
		12-500 151-45	55, 57, 116a, 117, 119, 123, 129, 135, 137, 139, 160, 163, 166, 173, 179	12-500 150-45	180, 183	12-640 090-55	61, 76, 81, 83, 91, 93, 101

No.	Seite Page Pages Página	No.	Seite Page Pages Página	No.	Seite Page Pages Página	No.	Seite Page Pages Página
12-640 130-55	100, 101	13-052 256-15	25, 121	14-215 007-13	48, 70, 100, 101, 149, 190	15-032 001-45	54, 55, 56, 57, 85, 87, 95, 97, 103, 115, 116a, 117, 118, 119, 122, 123, 124, 125, 128, 129, 131, 134, 135, 136, 137, 138, 139, 144, 150, 151, 152, 153, 154, 155, 158, 160, 163, 165, 166, 176, 177, 178, 179, 181
12-640 150-55	20, 24, 54, 56, 101, 105, 112, 115, 127, 131, 134, 136, 140	13-060 400-05	35, 39, 50, 63, 77, 88	14-215 010-13	70, 149	15-032 002-45	86, 96, 142, 143, 144, 145, 146, 147, 154, 164, 169, 170, 175, 182
12-640 170-55	31, 32, 37, 49, 50, 61 62, 65, 67, 69, 71, 76, 81, 85, 89, 91, 95, 98, 100, 105, 112, 115, 156, 190	13-068 187-15	83, 85, 93, 95	14-215 013-13	32, 37, 42, 50, 60, 61, 65, 67, 69, 71, 76, 80, 82, 83, 84, 85, 89, 90, 92, 93, 94, 95, 101	15-032 006-45	116
12-640 190-55	61, 81, 83, 91, 93	13-069 250-05	60	14-215 016-13	104, 110, 114	15-120 718-05	101
12-640 200-55	82, 84, 92, 94	13-070 981-05	54, 56, 118, 122, 124, 127, 134, 136, 140, 186	14-215 022-13	61, 80, 90	15-120 725-05	100, 101
12-640 210-55	22, 62, 86, 96, 154, 164, 182	13-115 022-05	24	14-215 025-13	101	15-120 762-05	101
12-640 250-55	32	13-210 471-05	63, 156, 186	14-215 028-13	19	15-120 787-05	100, 103
12-660 350-45	48, 190	13-240 201-05	51, 109, 113	14-215 043-13	60, 61, 80, 90	15-120 800-05	32
12-660 430-45	102	13-250 436-05	21	14-215 043-43	98	15-120 907-05	100
12-660 520-45	102	13-253 094-05	21	14-215 046-13	82, 84, 92, 94	15-128 060-75	29, 38
12-703 161-12	142, 143	13-280 103-05	30, 38	14-215 049-43	31, 37, 43, 49, 58, 65, 67, 69, 77, 78, 100, 101	15-280 001-01	102
12-710 902-12	85, 95	14-010 173-01	33, 34, 76	14-215 052-13	31, 82, 84, 92, 94	15-280 016-01	18, 101
13-030 185-05	102	14-012 525-01	48, 190	14-215 118-13	32	15-280 034-01	101
13-030 310-05	25	14-012 555-01	48, 190	14-215 253-33	31, 37, 49, 58, 65, 67, 69, 78	15-280 058-01	32
13-030 341-05	185, 187	14-015 624-91	49, 191	14-215 253-43	43, 101	15-822 336-01	103
13-033 097-05	81, 91	14-016 624-91	49, 191	14-215 304-43	71, 80, 83, 85, 90, 93, 95	15-823 730-01	38
13-033 103-05	22, 23, 40, 41, 47, 62, 73, 116, 191	14-016 080-01	61	14-650 214-05	20	16-041 035-21	156
13-033 220-05	166	14-016 101-91	28, 60	14-680 030-15	49, 191	16-041 055-21	176, 177
13-033 310-05	25	14-016 103-01	28, 60	14-680 050-15	28	16-049 020-11	26, 104, 110, 114
13-033 341-05	185, 187	14-016 150-01	58, 72, 78, 89, 102	14-680 060-15	24, 102	16-049 021-11	26, 104, 110, 114
13-033 097-05	81, 91	14-016 151-91	24, 102	14-680 070-15	24	16-049 040-11	121, 126, 142, 143, 144, 158, 176, 177
13-033 103-05	22, 23, 40, 41, 47, 62, 73, 116, 191	14-016 153-01	24, 102	14-680 420-15	28, 60	16-409 907-05	16, 100
13-033 220-05	166	14-017 620-01	49, 191	14-720 901-05	101	16-410 079-05	16, 102
13-033 244-05	108, 111, 114	14-018 570-01	18, 31, 36, 37, 39, 43, 44, 49, 58, 64, 65, 66, 67, 69, 77, 78			16-437 020-55	196
13-033 247-05	156	14-018 590-01	102			16-437 030-55	196
13-033 322-05	25	14-018 623-01	28			16-437 050-55	196
13-033 334-05	166	14-018 624-91	28				
13-033 340-05	71	14-018 643-01	24				
13-052 049-55	79, 111, 116b	14-018 644-91	24				
13-052 095-15	67	14-032 002-45	96				
13-052 248-15	54, 56, 118, 122, 124, 128, 134, 136, 138						

No.	Seite Page Pages Página	No.	Seite Page Pages Página	No.	Seite Page Pages Página	No.	Seite Page Pages Página
16-437 060-55	196	18-373 011-61	57, 85, 95, 116a, 117, 123, 129, 131, 137, 139	70-41 14-0162	53	71-14 00-0029	195
16-437 080-55	196			70-41 37-0023	106, 107	71-14 00-0032	195
16-437 090-55	196	18-378 001-61	56, 57, 87, 97, 116a, 117, 119, 123, 128, 129, 136, 137, 138, 139, 153, 155, 158, 165, 178, 181,	70-44 14-0151	53	71-15 00-0135	106, 107
16-437 100-55	196			70-44 14-3851	53	71-16 00-0065	122
16-437 120-55	196			71-11 00-0133	106, 107	71-16 00-0112	122
16-437 140-55	196	18-378 002-61	55, 57, 87, 97, 116a, 117, 119, 123, 129, 135, 137, 139, 153, 155, 160, 163, 178, 179, 181	71-11 00-0178	194	71-16 00-0118	57, 119, 122, 123, 129, 131, 137, 139
16-437 901-55	196			71-11 00-0183	106, 107, 192, 193	71-16 00-0119	113
16-437 906-55	196			71-11 00-0185	106, 107, 193	71-16 00-0120	113
16-437 908-55	196			71-11 00-0186	106, 107, 192, 193	71-16 00-0140	45, 46, 112, 133, 159, 172
16-919 051-15	83, 93	18-378 003-61	169, 170, 175	71-11 00-0213	192, 193	71-16 00-0141	46, 112, 133, 159, 172
17-035 232-45	98	18-378 008-61	142, 152, 153	71-11 00-0232	122	71-16 00-0142	46, 113, 133, 159, 172
18-277 001-91	57, 116a, 117, 119, 123, 125, 129, 137, 139, 158, 165	18-379 001-61	158, 165	71-11 00-0246	192, 193	71-16 00-0147	105
18-278 001-91	144	40-754 701-00	185	71-11 00-0262	192	71-16 00-0149	106, 107
18-278 005-91	57, 116a, 117, 119, 123, 129, 137, 139, 153 55, 57, 87, 97, 116a, 117, 119, 123, 129, 135, 137, 139, 153, 155, 160, 163, 178, 179, 181	61-111 642-19	187	71-12 00-0025	17, 44, 45, 46, 130, 132, 133, 141, 159, 171, 172	71-16 00-0150	106, 107
18-279 010-05	55, 57, 87, 97, 116a, 117, 119, 123, 129, 135, 137, 139, 153, 155, 160, 163, 178, 179, 181	61-111 643-06	187	71-12 00-0380	106, 107	71-16 00-0168	105
18-279 302-45	103	70-15 16-0110	106, 107, 162, 174	71-12 00-0559	109	71-16 00-0198	45, 113, 116a, 117, 118
18-372 001-61	55, 57, 115, 116a, 117, 118, 119, 123, 124, 125, 129, 135, 137, 139, 144, 150, 151, 152, 153, 154, 155, 158, 160, 163, 165, 166, 176, 177, 178, 179, 181	70-15 21-1102	17, 113	71-12 00-0569	106, 107	71-16 00-0199	45
18-372 003-61	86, 96, 142, 143, 144, 145, 146, 154, 164, 169, 170, 175, 182	70-15 21-4001	17, 162, 174	71-12 00-0575	17, 122	71-16 00-0204	131
18-372 004-61	145, 146, 147	70-15 21-4601	17, 162, 174	71-12 00-0576	17, 109, 122	71-16 00-0208	44, 54, 56, 128, 130, 131, 132, 135, 136, 138, 141, 171 128, 138
18-372 009-61	54, 56, 85, 87, 95, 97, 128, 134, 136, 138	70-15 21-5001	17, 161, 173	71-12 00-0577	17, 120	71-16 00-0250	128, 138
		70-15 21-5203	17, 108	71-13 00-0104	17, 105, 112	71-16 00-0263	162, 180, 183
		70-15 21-5403	17, 106, 107	71-13 00-0323	175	71-16 00-0277	45
		70-15 24-0016	17, 53	71-13 00-0326	161, 173	71-16 00-0278	45
		70-15 31-0001	106, 107, 162, 174	71-13 00-0375	162, 174	71-16 00-0317	162, 174
		70-16 31-5111	192, 194	71-13 00-0377	162, 174	71-16 00-0370	45, 46, 133, 159, 172
		70-16 32-0101	106, 107, 193, 194	71-13 00-0380	162, 174	71-17 00-0068	17, 105, 112
		70-16 83-0510	131	71-14 00-0003	109	71-17 00-0125	17, 51
		70-37 15-0001	171	71-14 00-0010	195	71-19 00-0040	106, 107
		70-37 15-0002	162, 174	71-14 00-0014	195	71-19 00-0068	106, 107
		70-37 45-0002	44, 45, 46, 130, 132, 133, 141, 159, 171, 172	71-14 00-0025	195	71-19 00-0070	107
		70-37 70-0006	54, 56, 57, 116a, 117, 118, 119, 123, 129, 135, 136, 137, 139			71-19 00-0167	161, 173

No.	Seite Page Pages Página	No.	Seite Page Pages Página	No.	Seite Page Pages Página	No.	Seite Page Pages Página
71-19 00-0188	53	71-37 00-0315	45, 46, 112, 133, 159, 172	71-63 00-0058	106, 107	91-010 181-25	116
71-21 00-0211	53	71-37 00-0317	45, 46, 112, 128, 133, 138, 159, 172	71-63 00-0065	161, 173	91-010 183-05	22, 23, 40, 41, 47, 73, 116, 191
71-21 00-0213	53	71-37 00-0320	192, 193	71-75 00-0028	161, 173	91-010 196-05	50
71-23 00-0118	17, 109	71-37 00-0332	192, 193	71-76 00-0072	161	91-010 542-05	142, 143
71-25 00-0147	106, 107	71-37 00-0333	192, 193	71-76 00-0078	162, 174	91-010 783-25	68
71-25 00-0160	106, 107	71-44 00-0131	106, 107	71-76 00-0127	161, 173	91-011 220-05	51
71-25 00-0267	17, 162, 174	71-44 00-0135	106, 107	71-85 00-0016	161, 173	91-012 754-05	31
71-37 00-0108	193, 194	71-54 00-0051	106, 107	71-85 00-0035	161, 173	91-017 378-05	31
71-37 00-0119	51	71-54 00-0066	106, 107	71-85 00-0049	180, 183	91-018 359-45	31
71-37 00-0133	18, 19, 25, 44, 45, 46, 130, 132, 133, 141, 159, 170, 171, 172, 175	71-55 00-0033	106, 107	71-85 00-0054	162, 180, 183, 184	91-020 490-15	20
71-37 00-0134	29, 30, 131	71-55 00-0087	108	71-85 00-0058	174	91-021 006-15	166
71-37 00-0135	105, 112	71-55 00-0139	162, 174	71-85 00-0062	180, 183, 184	91-021 124-15	116
71-37 00-0140	51	71-59 00-0089	121	71-85 00-0070	162	91-021 296-05	28
71-37 00-0158	51, 52, 105, 106, 107, 108, 162, 174	71-59 00-0098	121	91-000 243-15	70, 149	91-021 615-15	79, 104, 110, 111, 116b
71-37 00-0159	106, 107	71-59 00-0237	122	91-000 380-25	76	91-025 017-05	173, 174
71-37 00-0167	44, 46, 130, 132, 133, 141 159, 171, 172	71-59 00-0242	120	91-000 407-15	16, 30, 42, 44	91-025 170-15	86, 96, 154, 164, 182
71-37 00-0173	41, 45, 46, 105, 112, 130, 132, 133, 141, 159, 171, 172	71-59 00-0264	121	91-001 522-25	22, 23, 40, 41, 47, 73, 116, 191	91-025 374-05	64, 148
71-37 00-0174	52, 108, 162, 173, 174	71-59 00-0265	121	91-001 734-15	83, 93	91-025 376-05	64, 148
71-37 00-0175	162, 174	71-59 00-0274	109	91-001 824-05	61, 81, 83, 91, 93	91-027 289-15	54, 134, 186
71-37 00-0201	105	71-59 00-0306	113	91-002 065-05	16, 22, 23, 40, 41, 47, 66, 68, 73, 99, 116, 191	91-027 370-05	54, 86, 96, 134, 154, 164, 182, 186
71-37 00-0213	105, 112	71-59 00-0331	120	91-004 005-05	71	91-027 371-12	54, 86, 96, 134, 154, 164, 182, 186
71-37 00-0223	45, 161, 173	71-59 00-0332	120	91-004 006-05	71	91-028 200-15	68
71-37 00-0232	161	71-59 00-0333	17, 120	91-004 171-15	105, 112, 115	91-028 955-15	35
71-37 00-0260	52, 108, 161, 173	71-59 00-0334	120	91-006 093-05	64, 148	91-029 007-91	185
71-37 00-0286	161, 173	71-59 00-0335	120	91-007 329-05	104, 110, 114	91-029 033-45	185
71-37 00-0292	87, 97, 109, 113, 193, 194	71-59 00-0336	120	91-008 204-05	85, 95	91-029 385-51	63, 88, 186
71-37 00-0309	44, 45, 130, 132, 141, 159, 171	71-59 00-0368	120	91-009 276-05	47, 120, 191	91-029 394-01	185
71-37 00-0310	162, 174	71-63 00-0021	106, 107	91-010 115-05	71	91-029 450-15	185
		71-63 00-0046	53	91-010 116-05	71	91-029 521-05	32
		71-63 00-0049	45	91-010 181-15	22, 23, 40, 41, 47, 73, 191	91-029 692-45	86, 96, 154, 164, 182, 186
		71-63 00-0056	53, 106, 107			91-029 946-91	185

No.	Seite Page Pages Página	No.	Seite Page Pages Página	No.	Seite Page Pages Página	No.	Seite Page Pages Página
91-031 888-15	144	91-051 155-93	64, 148	91-069 135-05	27	91-082 306-25	168
91-032 087-45	186	91-053 235-21	68	91-069 139-91	27	91-082 307-05	166
91-032 291-15	144	91-053 727-21	59	91-069 165-15	104, 105, 110, 112, 114, 115	91-082 308-91	166
91-032 384-15	144	91-055 070-91	64, 148	91-069 172-15	187	91-082 309-15	166
91-032 477-91	50	91-055 075-15	64, 148	91-069 222-12	22, 26, 47, 58, 77, 191	91-082 316-05	167
91-032 478-25	50	91-055 321-91	64, 148	91-069 276-12	33, 62	91-082 317-05	167
91-032 479-05	50	91-055 322-91	64, 148	91-069 299-05	35	91-082 318-11	167
91-032 506-15	86, 96, 154, 164, 182	91-055 660-91	36	91-069 335-92	54, 134, 186	91-082 319-15	166
91-032 507-15	86, 96, 154, 164, 182	91-055 669-15	36	91-069 418-12	33	91-082 320-91	166
91-032 508-15	86, 96, 154, 164, 182	91-055 941-93	59	91-069 444-92	71, 90	91-082 321-15	166
91-032 509-15	86, 96, 154, 164, 182	91-056 193-25	70	91-069 471-25	70	91-082 325-05	167
91-032 510-15	86, 96, 154, 164, 182	91-056 760-05	70	91-069 474-92	80, 83, 85, 93, 95	91-082 326-15	166
91-032 511-12	86, 96, 154, 164, 182	91-058 155-05	64, 148	91-069 476-05	71, 80, 83, 85, 90, 93, 95	91-082 327-15	166
91-032 529-15	126	91-058 239-04	36	91-069 478-12	71, 90	91-082 328-15	166
91-032 543-11	144	91-058 536-04	59	91-069 600-15	81	91-082 329-15	166
91-032 559-15	144	91-058 656-04	157	91-069 601-15	81, 91	91-082 356-45	168
91-032 642-05	34	91-058 657-04	157	91-069 632-05	80, 83, 85, 90, 93, 95	91-082 357-15	171
91-032 800-91	185	91-058 658-04	157	91-069 634-92	116	91-082 358-01	166
91-032 801-91	185	91-058 660-04	157	91-069 709-12	48, 190	91-082 376-05	17, 166
91-032 802-45	185	91-058 662-04	157	91-069 712-05	76	91-082 388-45	64, 148, 163, 189
91-032 804-45	185	91-064 068-05	62	91-069 768-07	34	91-082 801-05	167
91-032 837-15	126, 142, 143, 158	91-064 638-05	22	91-069 809-45	38	91-082 802-01	167
91-032 953-15	144	91-066 094-05	60	91-069 845-15	38	91-082 803-05	167
91-033 073-90	147	91-068 074-05	32	91-069 961-05	108, 111, 114	91-082 806-05	167
91-038 617-15	126, 142, 143, 158	91-069 037-15	81, 91	91-069 992-25	70	91-082 807-01	167
91-038 738-45	55, 57, 87, 97, 117, 119, 123, 129, 135, 137, 139, 160, 163, 169	91-069 046-05	25	91-070 068-91	31	91-082 808-05	167
		91-069 049-05	18	91-082 300-91	166	91-082 809-01	167
		91-069 075-01	20	91-082 301-45	166	91-082 810-05	167
		91-069 079-92	20	91-082 302-15	166	91-082 858-05	166
91-044 251-21	76	91-069 127-05	26	91-082 303-91	166	91-082 889-05	17, 176, 177
91-047 384-05	36	91-069 131-91	26	91-082 304-91	168	91-083 345-75	176
91-047 608-04	64, 148	91-069 132-15	27	91-082 305-05	166	91-083 346-15	176, 177
91-047 860-04	59						

No.	Seite Page Pages Página	No.	Seite Page Pages Página	No.	Seite Page Pages Página	No.	Seite Page Pages Página
91-083 347-05	176, 177	91-084 157-15	173, 174	91-084 818-91	168	91-086 903-91	76
91-083 348-15	176, 177	91-084 158-15	173	91-084 819-25	168	91-086 904-01	76
91-083 350-12	176, 177	91-084 164-91	156	91-084 820-91	168	91-086 906-05	76
91-083 351-15	176, 177	91-084 171-91	64, 148, 189	91-084 821-25	168	91-087 097-25	152, 178
91-083 352-15	176, 177	91-084 180-91	86, 96, 154, 164, 182	91-085 065-05	47	91-087 100-45	152, 178
91-083 353-05	176, 177	91-084 182-91	158, 165	91-085 194-91	152	91-087 104-15	177
91-083 355-15	176, 177	91-084 256-92	76	91-085 195-15	44, 45, 46, 130, 132, 133, 141, 152, 159, 171, 172	91-087 144-71/798	152, 178
91-083 789-05	85, 95	91-084 257-05	76	91-086 000-11	184	91-087 145-75/798	152, 178
91-084 040-05	156	91-084 258-05	76	91-086 002-15	184	91-087 167-71/995	176
91-084 041-05	156	91-084 259-92	76	91-086 119-11	184	91-087 175-25	152, 178
91-084 043-15	156	91-084 264-12	76	91-086 170-11	180, 183	91-087 273-71/993	26
91-084 045-15	156	91-084 265-04	76	91-086 171-11	180, 183	91-087 282-11	26
91-084 046-91	163	91-084 271-15	76	91-086 176-45	142, 143, 144, 145, 147	91-087 294-15	26
91-084 047-15	156	91-084 279-91	76	91-086 176-75/993	146	91-087 295-95	26
91-084 061-05	156	91-084 280-15	76	91-086 253-75/995	177	91-087 296-75/995	26
91-084 062-05	156	91-084 290-15	76	91-086 258-91	177	91-087 306-75/993	26
91-084 063-05	17, 156	91-084 291-15	76	91-086 259-15	177	91-087 470-91	176, 177
91-084 064-05	156	91-084 293-91	77	91-086 260-15	176, 177	91-087 700-15	152
91-084 065-05	156	91-084 294-05	77	91-086 601-15	126, 142, 143, 158	91-087 700-25	152, 178
91-084 066-15	156	91-084 295-45	35, 77, 88	91-086 602-15	126, 142, 143, 158	91-087 906-15	26
91-084 070-15	156	91-084 318-05	77	91-086 609-91	126	91-087 907-15	26
91-084 071-91	156	91-084 409-15	176, 177	91-086 617-91	142, 143	91-087 908-71/993	26
91-084 088-91	157	91-084 440-45	166	91-086 623-91	126	91-087 918-25	178
91-084 097-15	161	91-084 441-91	168	91-086 626-91	158	91-088 197-75/798	26
91-084 098-15	161	91-084 442-25	168	91-086 732-15	176, 177	91-088 278-91	77
91-084 102-91	64, 148, 189	91-084 444-91	168	91-086 825-15	163	91-089 113-91	142
91-084 115-05	64, 148, 189	91-084 445-25	168	91-086 847-15	174	91-089 202-91	76
91-084 119-15	64, 148, 189	91-084 446-15	171	91-086 848-11	174	91-089 278-71/995	177
91-084 125-15	64, 148, 161, 173, 174	91-084 447-45	171	91-086 895-14	76	91-090 172-91	107
91-084 153-91	156	91-084 448-91	168	91-086 900-91	76	91-090 173-91	172
91-084 155-11	173	91-084 449-25	168	91-086 902-91	76	91-090 177-91	107
91-084 156-15	173, 174	91-084 756-45	152			91-090 190-91	107

No.	Seite Page Pages Página	No.	Seite Page Pages Página	No.	Seite Page Pages Página	No.	Seite Page Pages Página
91-090 191-91	107	91-095 362-91	46, 133, 159	91-097 149-15	55, 57, 118, 122, 124, 129, 135, 137, 139	91-106 401-05	102, 187
91-090 192-91	107	91-095 447-91	108	91-098 477-91	194	91-107 204-15	22, 23, 40, 41, 47, 73, 116, 191
91-090 217-01	109	91-095 590-91	106, 107	91-098 888-45	192, 193	91-107 265-05	61
91-090 277-05	53	91-095 613-01	109	91-099 392-91	46, 133, 159	91-107 266-05	100
91-090 583-91	192	91-095 645-91	193	91-099 515-91	108	91-107 268-05	102
91-090 584-91	192	91-095 647-91	193	91-099 613-91	106, 107	91-107 711-15	109, 195
91-090 585-91	192	91-095 648-91	193	91-099 766-91	193	91-107 723-05	109, 195
91-090 586-91	192	91-095 651-91	193	91-099 811-05	44, 130, 132, 141, 159, 171, 172	91-107 888-15	44, 45, 46, 130, 132, 133, 141, 159, 171, 172
91-090 824-91	112	91-095 789-91	106	91-100 055-15	35, 78, 89	91-107 889-15	44, 45, 46, 130, 132, 133, 141, 159, 171, 172
91-090 825-91	112	91-095 790-91	106	91-100 076-15	28, 59	91-107 890-05	44, 45, 46, 130, 132, 133, 141, 159, 171, 172
91-090 831-91	193	91-095 791-91	106	91-100 265-15	79, 104, 110, 111, 116b	91-107 891-15	44, 45, 46, 130, 132, 133, 141, 159, 171, 172
91-090 832-91	193	91-095 794-91	106, 107	91-100 270-15	22, 23, 44, 45, 46, 68, 73, 116, 130, 132, 133, 141, 152, 159, 171, 172	91-113 445-15	48, 83, 93, 190
91-090 850-45	52	91-095 795-91	106, 107	91-100 293-25	60	91-118 549-91	70
91-090 855-01	52	91-095 802-45	105, 112	91-100 296-25	17, 30, 42, 44, 59, 149, 157	91-118 766-05	103
91-090 859-05	53	91-095 803-91	105	91-100 300-15	36	91-118 893-92	32
91-090 922-91	53	91-095 804-91	105	91-100 318-25	68	91-118 953-15	121
91-090 988-91	116a, 117, 118	91-095 829-91	57, 119, 123, 129, 137, 139	91-100 325-05	167	91-118 955-15	121
91-091 503-91	180, 183	91-095 837-91	54, 56, 135, 136	91-100 330-15	24, 39, 47, 72, 78, 89	91-118 956-15	121
91-091 585-91	45	91-095 982-91	192	91-100 331-15	20	91-129 127-45	63, 88, 186
91-091 587-91	45	91-095 983-91	192	91-100 338-15	35	91-129 128-45	63, 88, 186
91-091 590-91	128, 138	91-095 984-91	192	91-101 756-05	27	91-129 138-91	7
91-091 688-91	53	91-095 985-91	192	91-101 758-15	27	91-129 153-91	185
91-091 770-05	53	91-095 997-91	192	91-101 775-05	185	91-129 203-90	195
91-091 862-91	52	91-096 178-91	194	91-105 442-15	27	91-129 916-91	7
91-092 189-45	173	91-096 181-91	194	91-105 444-15	62	91-129 917-91	7
91-092 210-91	44, 130, 132, 141, 171	91-096 183-91	194	91-105 447-15	22, 23, 40, 41, 47, 73, 191	91-129 919-91	7
91-092 752-45	162, 174	91-096 621-91	51	91-105 447-25	116	91-129 920-91	7
91-092 845-91	131	91-096 624-01	51				
91-092 846-91	131	91-096 625-01	51				
91-095 103-91	194	91-096 747-91	46, 133, 159				
91-095 141-91	106, 107	91-097 068-91	194				
91-095 145-01	109, 113	91-097 074-45	185				

No.	Seite Page Pages Página	No.	Seite Page Pages Página	No.	Seite Page Pages Página	No.	Seite Page Pages Página
91-129 941-91	7	91-165 583-95	131	91-169 000-91	42, 89	91-169 594-25	116
91-129 993-41	63, 88, 186	91-165 584-91	131	91-169 042-15	61, 81, 91	91-169 614-05	16, 30, 43, 75
91-131 259-05	60	91-165 588-91	131	91-169 074-05	60	91-169 615-05	16, 30, 43, 75
91-140 708-05	125	91-165 608-01	20	91-169 099-45	72, 78, 89	91-169 622-91	37, 65, 69, 78
91-158 122-01	42	91-165 609-05	20	91-169 119-05	105, 112, 115	91-169 623-15	77
91-158 353-01	17, 149	91-167 719-01	70, 149	91-169 121-01	70	91-169 633-15	22, 23, 40, 41, 73
91-158 847-91	74, 149	91-168 105-05	102, 103	91-169 132-15	61, 80, 90	91-169 633-25	116
91-158 848-25	74, 149	91-168 157-01	20, 72	91-169 137-05	22, 71, 108, 111, 114	91-169 654-12	32
91-165 501-45	131	91-168 222-11	166, 176, 177	91-169 166-05	39	91-169 658-05	22
91-165 502-45	131	91-168 231-45	187	91-169 197-15	156	91-169 659-12	22
91-165 504-15	131	91-168 244-04	16, 24	91-169 301-12	80, 83, 85, 93, 95	91-169 664-15	21
91-165 508-15	131	91-168 257-91	49, 191	91-169 304-15	25	91-169 670-15	16, 24
91-165 509-15	131	91-168 258-92	49, 191	91-169 322-15	64, 148	91-169 672-15	16, 24
91-165 510-05	131	91-168 317-15	68	91-169 323-15	64, 148	91-169 679-15	16, 22, 23, 40, 41, 66, 68, 99
91-165 511-15	131	91-168 319-12	82, 84, 92, 94	91-169 324-91	32	91-169 697-15	28, 59
91-165 512-05	131	91-168 322-05	31, 37, 43, 49, 58, 65,	91-169 353-05	60	91-169 702-92	21
91-165 513-15	131		67, 69, 77, 78	91-169 357-05	25	91-169 704-05	28, 59
91-165 514-15	131	91-168 329-05	33, 34, 76	91-169 393-12	80, 90	91-169 711-05	49, 69
91-165 515-15	131	91-168 335-05	33, 34, 76	91-169 395-04	17, 81, 83, 85, 185	91-169 715-92	17, 69
91-165 516-15	131	91-168 336-05	33, 34, 76	91-169 489-91	68	91-169 727-15	28, 37, 59, 64, 67, 69, 74, 75, 79, 88, 104, 110, 111, 116b, 148, 149, 157, 168
91-165 517-15	131	91-168 341-07	32	91-169 523-05	70, 101, 149	91-169 729-05	28, 59, 108, 111, 114
91-165 518-15	131	91-168 344-05	32	91-169 548-05	16, 22, 23, 40, 41, 66, 68, 73, 99	91-169 730-00	28
91-165 519-05	131	91-168 347-05	32	91-169 555-12	71	91-169 731-05	28
91-165 520-05	131	91-168 349-05	32	91-169 556-05	31, 32, 37, 49, 50, 62, 65, 67, 69, 71, 82, 83, 84, 85, 89, 90, 92, 93, 94, 95, 101	91-169 732-05	28
91-165 521-15	131	91-168 351-05	18	91-169 559-15	71	91-169 733-91	50
91-165 522-11	131	91-168 385-05	33	91-169 567-05	16, 22, 23, 40, 41, 47, 73, 116, 191	91-169 737-05	50
91-165 523-11	131	91-168 461-91	68	91-169 582-05	100	91-169 738-05	28, 50
91-165 524-15	131	91-168 480-15	24	91-169 588-92	71	91-169 741-21	24
91-165 525-15	131	91-168 496-92	33, 76	91-169 594-15	16, 22, 23, 40, 41, 73	91-169 744-25	24
91-165 526-05	131	91-168 833-07	33				
91-165 581-90	131	91-168 858-12	33				
91-165 582-91	131	91-168 957-05	79, 111, 116b				

No.	Seite Page Pages Página	No.	Seite Page Pages Página	No.	Seite Page Pages Página	No.	Seite Page Pages Página
91-169 745-91	16, 24	91-169 958-05	62	91-170 217-91	28	91-170 295-15	35
91-169 746-05	24	91-169 965-15	62	91-170 218-05	28	91-170 296-05	35
91-169 758-05	31	91-169 967-12	62	91-170 221-91	18	91-170 299-12	89
91-169 784-05	62	91-169 968-05	62	91-170 222-05	18, 36, 39, 44, 58, 64, 66	91-170 300-91	21
91-169 794-91	68	91-169 990-05	64, 148	91-170 223-92	18	91-170 301-05	21
91-169 796-25	22, 23, 40, 41, 66, 68, 73, 99	91-169 998-15	63	91-170 225-25	28	91-170 302-91	21
91-169 797-05	22, 23, 40, 41, 66, 68, 73, 99	91-170 110-15	104, 110, 114, 116	91-170 228-91	58, 72, 78, 89	91-170 305-12	32, 37, 50, 65, 67, 69, 71
91-169 801-05	22, 23, 40, 41, 66, 68, 73, 99	91-170 122-05	17, 105, 112, 115	91-170 229-11	58, 72, 78, 89	91-170 306-12	32, 37, 50, 65, 67, 69, 71, 89
91-169 803-05	68	91-170 127-91	108, 111, 114	91-170 234-05	31, 37, 43, 49, 58, 65, 67, 69, 77, 78	91-170 307-05	32, 37, 50, 65, 67, 69, 71, 89
91-169 806-05	68	91-170 133-05	104, 110, 114, 116	91-170 240-12	31	91-170 308-05	32, 37, 42, 50, 65, 67, 69, 71, 89
91-169 814-92	17, 31, 37, 43, 49, 65, 67, 77, 78	91-170 135-91	48, 190	91-170 245-92	19, 148	91-170 309-92	42
91-169 821-91	69	91-170 136-91	48, 190	91-170 258-91	66	91-170 311-92	32, 37, 50, 65, 67, 69, 71, 89
91-169 824-25	69	91-170 137-45	48, 190	91-170 259-01	66	91-170 315-12	42
91-169 842-91	62	91-170 138-15	48, 190	91-170 261-05	66	91-170 316-05	42
91-169 843-92	62	91-170 141-05	48, 190	91-170 262-05	66	91-170 331-91	36, 58, 64, 66
91-169 844-15	62	91-170 142-05	48, 190	91-170 270-93	79	91-170 332-92	36, 58, 64, 66
91-169 845-15	62	91-170 143-91	48, 190	91-170 271-23	79	91-170 340-91	28
91-169 846-12	62	91-170 144-05	48, 190	91-170 272-92	19, 36, 59, 64	91-170 341-25	28
91-169 848-92	28	91-170 148-05	48, 190	91-170 274-92	19, 79, 88	91-170 361-91	31, 43, 49, 58, 67, 77
91-169 865-05	88	91-170 149-05	48, 190	91-170 275-91	22	91-170 363-15	104, 110, 116b
91-169 866-05	74	91-170 152-05	49, 191	91-170 276-11	22, 23, 40, 41, 47, 73, 191	91-170 364-15	104, 110, 116b
91-169 867-05	43, 74	91-170 153-05	48, 190	91-170 278-91	23, 40	91-170 365-91	37, 64, 67, 74, 148
91-169 868-05	43, 74	91-170 154-90	48, 190	91-170 280-91	41, 73	91-170 366-25	37, 64, 67, 74, 148
91-169 876-05	74, 88	91-170 156-12	31, 37, 42, 49, 50, 62, 65, 67, 69, 71, 89	91-170 284-05	31	91-170 373-15	91
91-169 877-05	43, 74	91-170 175-12	48, 190	91-170 285-05	31	91-170 375-15	91
91-169 878-05	43, 74	91-170 201-45	35, 78, 88	91-170 286-05	31, 82, 84, 92, 94	91-170 378-05	66
91-169 886-00	74	91-170 202-45	35	91-170 290-91	22, 66, 68	91-170 379-05	17, 70
91-169 887-00	74	91-170 204-45	35, 50	91-170 291-91	22, 23, 66, 68, 73	91-170 381-45	72
91-169 888-00	74	91-170 206-45	35, 88	91-170 293-91	23	91-170 397-15	67
91-169 957-92	62	91-170 208-45	35, 63, 78, 88	91-170 294-91	73	91-170 406-91	20
		91-170 215-45	35, 63				

No.	Seite Page Pages Página	No.	Seite Page Pages Página	No.	Seite Page Pages Página	No.	Seite Page Pages Página
91-170 407-05	20, 36	91-170 476-45	62	91-170 843-92	31	91-170 971-45	105, 112, 115
91-170 408-15	16, 47	91-170 478-05	62	91-170 846-15	71	91-170 972-15	108, 111, 114
91-170 409-05	31	91-170 485-11	104, 110, 114	91-170 847-91	70	91-170 973-12	108, 111, 114
91-170 410-93	79	91-170 487-05	104, 110, 114	91-170 848-11	70	91-170 975-15	35
91-170 411-15	79	91-170 488-45	104, 110, 114	91-170 850-15	71	91-170 977-04	71
91-170 412-14	79	91-170 490-92	108, 111, 114	91-170 862-91	77	91-170 981-91	91
91-170 413-15	79, 111, 116b	91-170 495-21	89	91-170 874-91	24	91-170 982-15	91
91-170 416-05	17, 91, 185	91-170 500-25	88	91-170 875-91	36, 58, 65, 66	91-170 983-15	91
91-170 418-21	59	91-170 560-04	17, 81, 83, 85, 185	91-170 876-91	78, 89	91-170 984-91	70
91-170 419-05	60	91-170 693-05	16, 30, 43, 75	91-170 877-05	49, 191	91-170 985-15	70, 149
91-170 420-91	59	91-170 694-05	16, 30, 43, 75	91-170 878-05	28	91-170 986-12	70, 149
91-170 421-25	59	91-170 699-15	104, 110, 114, 116	91-170 890-12	31	91-170 987-12	72
91-170 422-25	59	91-170 700-15	104, 110, 114, 116	91-170 891-15	30, 43, 49, 59, 66, 69, 75	91-170 989-91	70, 149
91-170 423-15	16, 58	91-170 722-45	27	91-170 892-05	31	91-170 991-92	70, 149
91-170 424-91	59	91-170 725-91	27	91-170 897-91	31	91-170 992-45	70
91-170 425-05	59	91-170 726-05	27	91-170 913-92	24	91-170 993-05	72
91-170 426-05	59	91-170 737-91	31, 37, 43, 49, 58, 65, 67, 69, 77, 78	91-170 928-41	27	91-170 994-91	71
91-170 428-92	17, 58	91-169 741-91	120	91-170 929-92	26, 27	91-170 995-45	71
91-170 429-91	59	91-170 742-12	120	91-170 931-92	30, 66	91-170 996-15	16, 72
91-170 430-91	59	91-170 743-15	120	91-170 932-92	30, 43	91-171 004-45	187
91-170 431-15	59	91-170 744-15	120	91-170 935-92	49, 69	91-171 010-91	39, 44
91-170 433-91	59	91-170 759-05	48, 190	91-170 939-15	105, 112	91-171 011-12	24
91-170 434-25	59	91-170 760-12	48, 190	91-170 942-91	105, 112, 115	91-171 012-91	24
91-170 435-25	59	91-170 761-91	48, 190	91-170 943-11	105, 112, 115	91-171 050-05	20
91-170 436-05	59	91-170 783-91	46, 133, 159, 172	91-170 946-12	105, 112, 115	91-171 059-05	47, 191
91-170 440-05	17, 91, 93, 185	91-170 793-11	31, 37, 49, 68, 191	91-170 947-15	105, 112, 115	91-171 063-05	27
91-170 444-45	91	91-170 794-11	31, 37, 49, 68, 191	91-170 948-15	35	91-171 064-15	20
91-170 455-45	35	91-170 797-15	31, 37, 49, 68, 191	91-170 949-11	104, 110, 114	91-171 069-45	35
91-170 462-25	16, 73	91-170 836-91	19	91-170 950-15	104, 110, 114	91-171 072-92	20
91-170 474-91	62	91-170 837-01	19	91-170 966-05	37, 79, 88	91-171 075-91	64, 148
91-170 475-45	62	91-170 838-05	19	91-170 970-91	108, 111, 114	91-171 076-01	64, 148
91-170 476-05	38					91-171 087-05	64, 72, 80, 90, 148

No.	Seite Page Pages Página	No.	Seite Page Pages Página	No.	Seite Page Pages Página	No.	Seite Page Pages Página
91-171 097-91	39, 47	91-171 378-15	105, 112, 115	91-171 574-15	61	91-171 648-15	81, 91
91-171 098-91	24	91-171 410-01	20	91-171 575-91	61	91-171 649-15	81, 91
91-171 100-93	28	91-171 412-91	186	91-171 580-05	16, 60	91-171 650-03	81, 91
91-171 115-91	90	91-171 413-15	186	91-171 581-01	61	91-171 653-05	61, 81, 83, 91, 93
91-171 151-91	32	91-171 414-05	58, 135, 140	91-171 584-92	60	91-171 654-01	61, 81, 91
91-171 152-05	32	91-171 415-12	47, 131, 135, 140, 191	91-171 585-05	60	91-171 657-01	61, 81, 83, 91, 93
91-171 154-05	32	91-171 435-05	33	91-171 586-15	60	91-171 659-15	61, 81, 91
91-171 157-91	34	91-171 436-15	50	91-171 587-92	58	91-171 660-41	61, 81, 91
91-171 158-92	33, 34	91-171 453-05	50	91-171 605-05	60, 61, 80, 90	91-171 668-45	78, 89
91-171 159-05	33, 34, 76	91-171 462-70/993	146	91-171 607-04	61	91-171 669-05	64, 80, 90, 148
91-171 160-05	33, 34, 76	91-171 462-90	145	91-171 608-91	60	91-171 670-05	80, 83, 85, 90, 93, 95, 177
91-171 161-92	34	91-171 465-91	33	91-171 609-15	61	91-171 671-05	61, 81, 91
91-171 163-92	33, 34, 76	91-171 466-05	33, 76	91-171 613-15	60	91-171 672-45	81, 91
91-171 164-92	33, 34, 76	91-171 467-04	33	91-171 614-15	60	91-171 682-15	81, 91
91-171 166-07	34	91-171 478-91	33, 76	91-171 625-91	60	91-171 683-91	60
91-171 167-05	33	91-171 496-45	61	91-171 626-45	60	91-171 684-45	60
91-171 176-45	28	91-171 520-15	25	91-171 627-45	44, 45, 46, 130, 132, 133, 141, 159, 171, 172	91-171 686-15	60
91-171 177-05	32	91-171 535-15	35	91-171 631-45	81, 91	91-171 687-05	60
91-171 181-05	35	91-171 536-15	35	91-171 632-91	80	91-171 688-05	60
91-171 182-15	35	91-171 537-45	186	91-171 633-41	80, 90	91-171 689-11	60
91-171 182-92	35	91-171 539-12	121	91-171 637-12	61, 80, 90	91-171 691-15	61
91-171 204-04	34	91-171 540-91	25	91-171 638-05	60, 61, 80, 90	91-171 697-01	60
91-171 205-07	33	91-171 541-15	25	91-171 639-15	61, 80, 90	91-171 744-05	33
91-171 229-05	82, 84, 92, 94	91-171 542-91	54, 56, 118, 121, 122, 124, 127, 134, 136, 140, 186	91-171 640-15	80, 90	91-171 775-15	142
91-171 250-91	144	91-171 543-05	54, 56, 118, 121, 122, 124, 127, 134, 136, 140, 186	91-171 641-12	61, 80, 90	91-171 811-05	20
91-171 256-45	170	91-171 544-12	54, 56, 118, 121, 122, 124, 127, 134, 136, 140, 186	91-171 642-12	61, 80, 90	91-171 816-91	90
91-171 283-91	20	91-171 557-05	64, 148	91-171 643-15	80, 90	91-171 829-25	183, 184
91-171 288-12	50	91-171 571-92	61	91-171 644-92	80	91-171 847-11	105, 112
91-171 289-15	51	91-171 572-91	61	91-171 645-91	81	91-171 883-15	27
91-171 294-15	51			91-171 646-15	81, 91	91-171 903-15	27
91-171 337-12	33			91-171 647-05	81	91-171 904-91	27
91-171 377-91	34					91-171 905-91	27

No.	Seite Page Pages Página	No.	Seite Page Pages Página	No.	Seite Page Pages Página	No.	Seite Page Pages Página
91-171906-45	27	91-172 026-05	31, 37, 43, 49, 58, 65, 67, 69, 77, 78	91-172 110-15	67	91-172 195-15	28, 50
91-171907-91	26			91-172 111-15	67	91-172 197-05	30
91-171948-92	20	91-172 027-05	25	91-172 112-15	104, 110, 114, 116	91-172 198-05	42, 89
91-171949-05	20	91-172 028-05	25	91-172 119-15	28	91-172 200-05	66, 68
91-171955-91	80	91-172 029-12	16, 19	91-172 122-01	28	91-172 204-91	37
91-171956-91	90	91-172 030-15	19	91-172 123-15	16, 70	91-172 208-91	28
91-171957-91	60	91-172 031-05	29, 30	91-172 124-05	74	91-172 209-12	28
91-171971-05	39, 44	91-172 032-05	29	91-172 130-91	104, 110, 114	91-172 211-05	48, 190
91-171973-41	143	91-172 033-05	18	91-172 131-01	17, 104, 110, 114	91-172 213-91	72
91-171993-12	33	91-172 035-05	18	91-172 136-00	88	91-172 215-91	62
91-172002-05	18	91-172 036-15	18	91-172 140-05	74, 75	91-172 220-91	105
91-172003-45	18, 78, 89	91-172 037-15	18	91-172 142-15	19	91-172 221-01	59
91-172003-92	18	91-172 042-05	29	91-172 148-15	104, 110, 114	91-172 224-05	38
91-172005-91	29	91-172 044-92	19	91-172 149-15	19	91-172 231-05	31, 49, 62
91-172006-15	18	91-172 045-05	29, 38, 63	91-172 151-91	104, 110, 114	91-172 232-45	105, 112, 115
91-172007-05	18	91-172 046-05	29	91-172 160-91	74, 157	91-172 235-91	37
91-172008-05	18	91-172 056-91	39, 44	91-172 161-91	72	91-172 238-91	62
91-172009-05	18	91-172 059-15	48, 190	91-172 162-05	72	91-172 239-91	62
91-172010-91	18	91-172 060-11	29	91-172 163-91	71	91-172 242-91	16, 19
91-172011-15	18	91-172 063-05	29	91-172 166-91	31, 37, 43, 49, 58, 65, 67, 69, 78	91-172 243-15	19
91-172012-92	19, 44	91-172 064-15	29, 38	91-172 169-91	69	91-172 244-15	19
91-172013-91	25	91-172 069-91	104, 110, 116b	91-172 170-05	69	91-172 253-05	59, 64, 79, 89, 148
91-172014-05	29	91-172 076-91	89	91-172 171-91	43, 49, 58, 67	91-172 256-12	90
91-172017-15	29	91-172 077-91	37	91-172 172-05	43, 49, 58, 67	91-172 304-91	31
91-172018-45	31	91-172 078-91	50, 65, 67, 69, 71	91-172 173-91	37, 65, 78	91-172 311-04	19
91-172019-15	29, 38	91-172 085-91	60	91-172 174-05	37, 65, 78	91-172 312-05	120
91-172020-05	18	91-172 088-45	38	91-172 175-91	31	91-172 313-05	79, 104, 110, 111, 116b
91-172021-05	29	91-172 090-11	50	91-172 176-05	31	91-172 314-05	79, 104, 110, 111, 116b
91-172022-05	29	91-172 093-11	28	91-172 179-05	31, 37, 43, 49, 58, 65, 67, 69, 78	91-172 315-91	32
91-172023-05	29	91-172 102-15	79, 104, 110, 111, 116b	91-172 180-15	62	91-172 335-05	68, 74, 75
91-172025-15	31, 37, 43, 49, 58, 65, 67, 69, 77, 78	91-172 106-91	67	91-172 194-92	80, 90	91-172 338-12	19, 39, 68, 74, 75, 88
		91-172 107-11	67			91-172 357-05	48, 190

No.	Seite Page Pages Página	No.	Seite Page Pages Página	No.	Seite Page Pages Página	No.	Seite Page Pages Página
91-172 358-05	17, 79, 104, 110, 111, 116b	91-172 451-93	74	91-172 925-15	56, 118, 122, 124, 127, 136, 140	91-175 613-05	82, 84, 92, 94
91-172 361-12	104, 110, 115	91-172 452-93	74	91-172 925-92	56, 118, 122, 124, 127, 136, 140	91-175 614-05	82, 84, 92, 94
91-172 366-05	19, 39, 88	91-172 454-05	28	91-172 942-15	54, 56, 85, 95, 128, 134, 136, 138	91-175 615-12	82, 84, 92, 94
91-172 371-11	36	91-172 455-05	30	91-172 958-91	20	91-175 616-12	82, 84, 92, 94
91-172 377-90	47, 191	91-172 456-05	30	91-172 959-91	20	91-175 617-05	82, 84, 92, 94
91-172 378-91	47, 191	91-172 557-01	36	91-172 961-05	20	91-175 618-15	82, 84, 92, 94
91-172 379-15	47, 191	91-172 560-45	115	91-172 995-92	54, 134	91-175 619-15	82, 84, 92, 94
91-172 380-15	16, 47, 191	91-172 572-15	31, 43	91-172 996-91	54, 134	91-175 620-12	83, 85, 93, 95
91-172 381-15	47, 191	91-172 578-91	112	91-174 016-05	16, 18	91-175 621-05	83, 85, 93, 95
91-172 382-15	47, 191	91-172 579-01	19	91-174 033-05	35	91-175 622-15	83, 93
91-172 383-15	47, 191	91-172 580-91	32, 37, 50, 65, 67, 69, 71, 89	91-174 081-05	83, 85, 93, 95	91-175 623-05	83, 93
91-172 385-92	47, 191	91-172 581-91	32, 37, 50, 65, 67, 69, 71	91-174 142-11	25	91-175 624-03	83, 93
91-172 386-15	47, 191	91-172 583-45	68	91-174 276-05	16, 18	91-175 627-01	83, 93
91-172 399-05	38	91-172 594-91	69	91-174 277-91	18	91-175 632-12	82, 84, 92, 94
91-172 400-45	19	91-172 595-91	43, 49, 58, 67	91-174 385-15	184	91-175 633-05	82, 84, 92, 94
91-172 401-05	19	91-172 596-91	37, 65, 78	91-175 134-91	163	91-175 634-05	82, 84, 92, 94
91-172 406-91	38	91-172 597-91	31	91-175 217-15	27	91-175 635-05	82, 84, 92, 94
91-172 407-91	38	91-172 599-91	104, 110, 116b	91-175 506-91	118, 122, 124	91-175 636-05	83, 93
91-172 408-45	38	91-172 710-15	88	91-175 512-91	54, 134	91-175 637-91	83, 85, 93, 95
91-172 409-15	38	91-172 765-91	88	91-175 513-91	55, 135, 160	91-175 638-05	83, 85, 93, 95
91-172 410-05	38	91-172 856-01	38, 63	91-175 514-91	117, 123	91-175 639-45	82, 84, 92, 94
91-172 411-05	38	91-172 875-91	36	91-175 515-45	175	91-175 640-92	82, 84, 92, 94
91-172 412-05	38	91-172 903-45	54, 56, 118, 122, 124, 128, 134, 136, 138	91-175 520-91	56, 128, 136, 138	91-175 642-05	82, 84, 92, 94
91-172 413-05	38, 63	91-172 903-92	54, 56, 118, 122, 124, 128, 134, 136, 138	91-175 529-91	57, 137	91-175 643-15	82, 84
91-172 414-15	30, 38	91-172 910-05	56, 118, 122, 124, 128, 136, 138	91-175 530-91	129, 139	91-175 644-15	92, 94
91-172 417-91	30	91-172 913-11	54, 56, 128, 134, 136, 138	91-175 539-05	32	91-175 645-11	83, 85
91-172 427-91	19	91-172 916-91	115	91-175 595-12	54, 56, 127, 134, 136, 140	91-175 646-15	83, 85, 93, 95
91-172 429-05	63	91-172 917-91	50, 65, 67, 69, 71	91-175 610-45	82, 84, 92, 94	91-175 647-15	83, 85
91-172 442-93	88	91-172 919-15	115	91-175 610-92	82, 84, 92, 94	91-175 648-15	83, 85, 93, 95
91-172 443-93	39, 88			91-175 611-05	82, 84, 92, 94	91-175 649-15	83, 85, 93, 95
91-172 449-93	88			91-175 612-07	82, 84, 92, 94	91-175 650-15	82, 84, 92, 94
91-172 450-93	68						

No.	Seite Page Pages Página	No.	Seite Page Pages Página	No.	Seite Page Pages Página	No.	Seite Page Pages Página
91-175 653-05	82, 84, 92, 94	91-176 574-91	103	91-176 626-05	101	91-176 660-92	102
91-175 716-15	54, 56, 128, 134, 136, 138	91-176 575-45	103	91-176 627-15	101	91-176 661-11	102
91-175 717-15	118, 122, 124	91-176 576-05	103	91-176 628-05	101	91-176 664-01	102
91-175 718-15	82, 84	91-176 577-05	103	91-176 629-15	103	91-176 665-05	102
91-175 741-91	54, 56, 128, 134, 136, 138	91-176 578-05	103	91-176 630-05	103	91-176 667-05	103
91-175 747-13	85, 95	91-176 579-15	103	91-176 631-15	103	91-176 668-12	102
91-175 751-41	85, 95	91-176 580-91	100	91-176 632-15	103	91-176 672-15	101, 187
91-175 754-15	85, 95	91-176 581-01	100	91-176 633-15	101	91-176 673-91	102
91-175 756-91	84	91-176 585-05	100	91-176 634-45	103	91-176 675-45	103
91-175 758-91	87, 97	91-176 586-05	100	91-176 635-45	103	91-176 676-41	103
91-175 771-91	64, 148, 163, 189	91-176 587-05	100	91-176 636-45	103	91-176 680-05	103
91-175 781-91	94	91-176 589-05	100	91-176 637-91	101	91-176 689-05	103
91-175 789-05	51	91-176 590-15	100	91-176 638-05	101	91-176 690-05	103
91-175 792-45	171	91-176 597-01	17, 91, 185	91-176 639-92	101	91-176 691-15	100
91-175 793-05	93, 95	91-176 599-45	103	91-176 640-05	101	91-176 692-45	102, 187
91-175 794-11	93, 95	91-176 600-05	100	91-176 641-05	101	91-176 693-91	99
91-175 795-15	93, 95	91-176 601-05	100	91-176 643-05	101	91-176 694-11	40, 41, 99
91-175 898-91	54, 56, 128, 134, 136, 138	91-176 602-05	100	91-176 644-91	101	91-176 697-91	40, 99
91-175 916-91	115	91-176 604-05	103	91-176 645-05	101	91-176 698-91	41, 99
91-176 051-91	119	91-176 606-01	101	91-176 646-05	101	91-176 712-12	100
91-176 063-15	131	91-176 610-91	101	91-176 647-91	101	91-176 715-91	100
91-176 123-05	98	91-176 611-15	101	91-176 648-92	101	91-176 721-02	100
91-176 130-01	39, 98	91-176 612-05	101	91-176 649-11	101	91-176 722-92	100
91-176 142-41	83, 93	91-176 613-05	101	91-176 652-05	101	91-176 723-02	100
91-176 147-05	100	91-176 614-05	101	91-176 653-05	101	91-176 724-15	100
91-176 148-91	82	91-176 615-12	101	91-176 654-05	101	91-176 725-92	100
91-176 149-91	92	91-176 616-11	101	91-176 655-12	101	91-176 726-91	98
91-176 415-91	98	91-176 621-05	101	91-176 656-01	102	91-176 727-41	98
91-176 502-25	88	91-176 622-05	101	91-176 657-05	102	91-176 730-15	98
91-176 536-91	88	91-176 623-91	101	91-176 658-91	102	91-176 731-15	98
91-176 537-01	17, 91	91-176 624-01	101	91-176 659-15	102	91-176 735-05	39, 98
91-176 572-05	39	91-176 625-05	101			91-176 755-92	98

No.	Seite Page Pages Página	No.	Seite Page Pages Página	No.	Seite Page Pages Página	No.	Seite Page Pages Página
91-176 756-05	98, 125	91-177 150-12	151	91-178 029-21	116	91-700 335-15	19, 24, 47, 58, 59, 60, 61, 70, 71, 81, 82, 84, 89, 91, 92, 94, 131, 142, 173, 174
91-176 764-05	98	91-177 152-05	17, 151	91-178 041-75/995	70, 149	91-700 335-25	26, 178, 183, 184
91-176 774-45	100	91-177 153-45	151	91-178 042-15	150	91-700 388-15	64, 148
91-176 784-15	98	91-177 218-92	43	91-178 043-05	17, 150	91-700 409-15	64, 148
91-176 786-15	102, 187	91-177 298-91	151	91-178 044-25	75, 149	91-700 412-25	22, 23
91-176 793-45	98	91-177 303-15	98	91-178 045-71/995	70, 149	91-700 680-15	60
91-176 794-12	98	91-177 322-15	98	91-178 046-91	75, 149	91-700 687-15	60
91-176 805-15	98	91-177 325-01	98	91-178 049-15	150	91-700 689-15	32, 49, 58, 191
91-176 806-12	98	91-177 327-01	98	91-178 050-25	74	91-700 717-15	64, 148
91-176 831-41	152	91-177 330-05	98	91-178 073-93	39	91-700 785-15	33, 62, 82, 84, 92, 94
91-176 835-15	125	91-177 331-05	98	91-178 074-93	39	91-701 319-15	18, 47, 191
91-176 836-15	125	91-177 334-01	98	91-178 075-90	85, 95	91-701 344-15	22, 23, 40, 41, 47, 66, 68, 73, 99, 116, 191
91-176 839-91	103	91-177 342-91	98	91-178 080-15	72	91-701 370-15	27
91-176 849-15	98	91-177 343-91	98	91-178 084-05	31, 37, 43, 49, 58, 65, 67, 69, 78	91-701 664-15	25
91-176 875-12	83, 85, 93, 95	91-177 464-45	55, 57, 87, 97, 116a, 117, 119, 123, 129, 135, 137, 139, 153, 155, 160, 163, 169, 178, 179, 181	91-178 090-05	17, 111, 116b	95-600 576-05	116
91-176 947-15	126, 142, 143, 158	91-177 536-91	150	91-178 096-93	79, 111, 116b	95-602 137-05	116
91-176 948-12	126, 142, 143, 158	91-177 592-05	98	91-178 097-15	79, 111, 116b	95-617 317-15	54, 56, 128, 134, 136, 138
91-176 979-92	43	91-178 001-92	75	91-178 098-14	79, 111, 116b	95-632 297-15	116
91-176 980-05	43, 75	91-178 002-91	49	91-178 100-05	111, 116b	95-632 305-15	116
91-176 981-05	43, 75	91-178 010-15	98	91-178 165-25	104, 110, 111, 116b	95-638 706-91	173
91-176 982-05	43, 75	91-178 011-92	75	91-178 167-91	125	95-638 708-91	161, 173
91-176 983-12	42	91-178 018-91	169	91-178 185-91	111, 116b	95-638 709-91	175
91-176 985-05	42	91-178 019-91	169, 175	91-178 188-91	42	95-638 759-91	161
91-176 986-92	17, 43, 75	91-178 021-05	75	91-493 201-93	144	95-639 120-90	161
91-176 988-45	35, 39	91-178 021-92	75	91-700 018-15	68	95-639 121-90	173
91-176 989-93	39	91-178 022-05	75	91-700 113-25	59	95-780 123-91	162, 174
91-176 991-91	42	91-178 025-91	75	91-700 169-15	28	95-781 051-91	162, 174
91-176 993-91	19	91-178 026-01	17, 116	91-700 226-15	17, 37, 64, 67, 69, 74, 75, 79, 88, 104, 110, 111, 116b, 120, 148, 149, 157, 168,	95-781 284-91	162, 174
91-177 084-05	98	91-178 027-91	116			97-30 117-345	185
91-177 147-45	150, 151	91-178 028-91	116			97-30 179-995	63, 156, 186
91-177 148-05	150, 151						
91-177 149-05	150, 151						

No.	Seite Page Pages Página	No.	Seite Page Pages Página	No.	Seite Page Pages Página	No.	Seite Page Pages Página
97-30 180-995	63	99-133 968-91	126, 142, 143, 158	99-134 851-91	150, 151, 176, 177	99-136 010-91	178
99-029 728-05	61, 81, 83, 85, 91	99-134 008-91	54, 55, 56, 57, 116a, 117, 118, 119, 123, 128, 129, 135, 136, 137, 138, 139, 160, 161, 162, 163, 174, 175	99-135 016-91	87, 89, 97	280-1-120 144	7
99-069 707-01	71	99-134 089-05	64, 148, 189	99-135 108-91	116, 126, 131, 142, 143, 158	280-1-120 217	7
99-069 713-01	76	99-134 093-05	64, 148, 189	99-135 126-91	172	280-1-120 239	7
99-096 072-91	122	99-134 132-61	116a, 126	99-135 156-91	172	280-1-120 243	7
99-115 187-21	185	99-134 195-91	142, 143, 144, 147	99-135 206-91	56, 118, 122, 124, 128, 136, 138	280-1-120 247	7
99-115 231-91	145	99-134 206-05	54, 56, 87, 97, 128, 134, 136, 138	99-135 207-91	150	294-1-102 312	25, 29, 30, 38, 63
99-115 300-91	131, 144, 145, 146	99-134 224-15	138	99-135 233-91	142	24 101-2.205-4	44, 57, 119, 123, 128, 129, 130, 132, 137, 138, 139, 141, 171
99-115 301-05	142, 143, 144, 145, 147	99-134 225-05	31, 37, 43, 49, 58, 65, 67, 69, 78	99-135 350-91	57, 116a, 117, 119, 123, 129, 137, 139	24 101-2.207-4	162, 174
99-115 423-91	144	99-134 294-91	166	99-135 370-91	169	24 101-2.306-4	46, 52, 133, 159, 162, 172, 174, 175
99-115 425-91	54, 56, 87, 97, 128, 134, 136, 138	99-134 299-91	57, 116a, 117, 119, 123, 129, 137, 139, 152	99-135 496-95	152, 155	24 132-2.204-4	45, 54, 56, 116a, 117, 118, 135, 136
99-115 505-91	118, 124, 125, 152, 154, 158, 165	99-134 350-91	156	99-135 549-91	143	24 132-2.304-4	45
99-115 576-91	151	99-134 369-91	57, 116a, 117, 119, 123, 129, 137, 139	99-135 625-91	131	24 140-2.208-4	45, 46, 133, 159, 161, 173
99-115 626-91	86, 86, 154, 164, 182	99-134 370-91	129, 139, 163	99-135 626-91	131	25 134-8.004-0	54, 55, 56, 57, 86, 96, 116, 116a, 117, 118, 119, 123, 124, 128, 129, 134, 135, 136, 137, 138, 139, 142, 144, 145, 146, 150, 151, 152, 153, 154, 155, 156, 158, 160, 163, 164, 165, 169, 170, 175, 176, 177
99-115 627-91	170, 175	99-134 437-91	55, 57, 129, 135, 137, 139 160, 163, 179	99-135 627-91	131	25 134-8.005-0	55, 57, 87, 97, 116a, 117, 119, 123, 129, 135, 137, 139, 145, 146, 147, 160, 163, 169, 178, 179, 181
99-133 042-91	116a, 152, 153, 155, 178, 181	99-134 442-91	146	99-135 629-05	131	25 134-8.035-0	87, 97, 144, 152
99-133 122-91	153, 155, 158, 165, 178, 181	99-134 445-91	55, 57, 135, 137, 160, 179	99-135 630-91	131	25 135-8.002-0	54, 56, 128, 131, 134, 136, 138
99-133 124-91	116a, 152, 155	99-134 452-91	57, 116a, 117, 119, 123, 129, 137, 139	99-135 625-91	131	25 135-8.004-0	125, 126, 131
99-133 265-91	173	99-134 544-55	64, 148, 163, 189	99-135 715-91	152, 178	25 308-8.203-0	142, 178
99-133 402-91	176, 177	99-134 561-91	162, 174	99-135 774-91	131	25 308-8.203-3	142
99-133 676-91	115	99-134 578-91	169	99-135 775-91	131		
99-133 752-01	55, 57, 87, 97, 116a, 117, 119, 123, 129, 135, 137, 139, 153, 155, 160, 163, 178, 179, 181	99-134 581-91	152	99-135 776-91	131		
99-133 753-91	156	99-134 586-91	54, 56, 128, 134, 136, 138	99-135 777-95	131		
99-133 905-91	54, 56, 87, 97, 128, 134, 136, 138, 156, 166	99-134 587-91	54, 56, 128, 134, 136, 138	99-135 778-91	131		
99-133 917-91	144	99-134 775-91	54, 56, 85, 95, 128, 134, 136, 138	99-135 779-45	131		
99-133 922-05	131	99-134 850-91	118, 122, 124, 125	99-135 780-91	131		
99-133 934-91	116			99-135 781-91	131		
				99-135 782-45	131		
				99-135 783-91	131		
				99-135 835-05	152		
				99-135 836-91	131		
				99-135 885-91	125		

No.	Seite Page Pages Página	No.	Seite Page Pages Página
25 308-8.204-0	143, 178, 179, 181, 182		
25 401-6.202-5	174		
26 536-3.040-9	82, 84, 92, 94		

Pfaff, D 6750 Kaiserslautern, Postfach 3020/3040, Telex: 045 753, Telefax (0631) 17202

PFAFF[®]

5483

Unterklassen-Ausstattung
Subclass parts
Composition des sous-classes
Composición de las subclases

Unterklassen-Ausstattung¹⁾

Subclass organization¹⁾

Unterklasse Subclass Sous-classe Subclasse	Ausführung Model Version Tipo de máquina	Nadelstange Needle bar Barre à aiguille Barra de aguja	Stoffschieber ⁴⁾ Feed dog Griffe Transportador interior	Stichplatte ⁴⁾ Needle plate Plaque à aiguille Placa de aguja	Nähfuß ⁴⁾ Presser foot Pied presseur Pie prensateelas	Kettfuß Chaining foot Pied boucleur Pie para cadeneta
-814/01	1-Nadel-Ausführung · Single-needle version					
-6/01	B	91-170 245-92	91-047 539-04	91-058 235-04	91-054 950-93	
	BN	91-170 245-92	91-047 851-04	91-158 427-04	91-054 950-91	
-6/01-900/51;/71	B	91-170 245-92	91-047 349-04	91-058 408-04	91-054 948-01	
	BN	91-170 245-92	91-047 851-04	91-158 427-04	91-054 948-01	
-6/02 ^{30/0}	AN 3,5 BN 3,5	91-170 245-92	91-047 384-05	91-058 239-04	91-054 883-91	
-6/02-900/.. ^{30/0}	AN 3,5 BN 3,5	91-170 245-92	91-047 582-05	91-058 409-04	91-054 883-91	
-6/10	AN 3,5 BN 3,5	91-170 245-92	91-047 384-05	91-058 239-04	91-055 789-91	
-6/10-900/51;/71	AN 3,5 BN 3,5	91-170 245-92	91-047 833-05	91-058 409-04	91-055 790-91	
-17/31	A B	91-170 245-92	91-047 628-04	91-058 196-05	91-055 081-91	
-19/01 (-900/51;/71)* ¹³ = 4 – 15 mm	AN 3,5 BN 3,5	91-170 245-92	91-047 830-05	91-058 445-04	91-055 040-93 ^{12/2}	
-19/05 (-900/51;/71)* ¹³ = 5 – 15 mm	AN 3,5 BN 3,5	91-170 245-92	91-047 830-05	91-058 445-04	91-055 040-93 ^{12/2}	
-19/05-920/11 ¹³ = 5 – 15 mm	AN 3,5 BN 3,5	91-170 245-92	91-047 830-05	91-058 445-04	91-055 040-93 ^{12/2}	
-39/31	A B	91-170 245-92	91-047 628-04	91-058 196-05	91-055 081-91	
-193/01	B	91-170 245-92	91-460 077-05	91-460 076-05	91-460 078-01	
-944/01	AN 3,5 BN 3,5	91-170 245-92	91-047 608-04	91-058 155-05	91-051 155-93	91-055 070-91
R-814/01	1-Nadel-Ausführung · Single-needle version					
-6/02	AN 3,5	91-170 272-92	91-047 384-05	91-058 239-04	91-157 978-91	
-6/02-960/81	AN 3,5	91-170 272-92	91-047 539-04	91-158 595-93	91-157 978-91	
H-814/01	1-Nadel-Ausführung · Single-needle version					
-6/01 (-900/..)* -911/.. ^{30/0}	A B	91-172 012-92	91-047 349-04	91-058 408-04	91-054 948-91 ● 91-054 950-91	
-6/02 (-900/51;/71)* -911/03;/05	AN 3,5	91-172 012-92	91-047 319-05	91-058 484-05	91-055 787-01 ● 91-055 792-01	
-6/02 (-900/51;/71)* -911/03;/05	BN 3,5	91-172 012-92	91-047 833-05	91-058 455-05	91-055 787-01 ● 91-055 792-01	
-6/10-911/03;/05	BN 3,5	91-172 012-92	91-047 833-05	91-058 409-04	91-055 789-91	
-6/10-900/51;/71-911/03;/05	BN 3,5	91-172 012-92	91-047 833-05	91-058 455-05	91-055 790-91	
-6/12-900/51;/71-911/03	BN 3,5	91-172 012-92	91-047 833-05	91-058 455-05	91-055 730-91	

Erläuterungen siehe Seite 10 und 11
For explanations see pages 10 and 11
Explications, voir pages 10 et 11
Para las explicaciones, véanse páginas 10 y 11

Equipement des sous-classes¹⁾

Dotación de las subclases¹⁾

Apparat
Attachment
Appareil
Aparato

Träger
Bracket
Support
Soporte

Bandrollenträger
Tape reel bracket
Plateau dérouleur
Portarrollos

Kettensichgreifer
Looper
Boucleur
Garfo para punto
cadeneta

Nadelschutz
Needle guard
Garde-aiguille
Gardaaguja

Abdeckplatte
Cover plate
Plaque de recouvrement
Placa cubierta

Durchziehhaken
Pull-through hook
Tira-ruban
Gancho

Modèle à 1 aiguille · Tipo de 1 aguja

			91-170 966-05	91-172 253-05	91-170 365-91	
			91-170 966-05	91-172 253-05	91-170 365-91	
			91-170 966-05	91-172 253-05	91-172 069-91	
			91-170 966-05	91-172 253-05	91-172 069-91	
			91-170 966-05	91-172 253-05	91-170 365-91	
			91-170 966-05	91-172 253-05	91-172 069-91	
			91-170 966-05	91-172 253-05	91-170 365-91	
			91-170 966-05	91-172 253-05	91-172 069-91	
91-050 545-21	91-053 988-91	91-050 966-91	91-170 966-05	91-172 253-05	91-170 438-91	
91-050 549-23			91-170 966-05	91-172 253-05	91-172 218-91 91-172 599-91 ●	
91-041 398-23	91-753 936-90		91-170 966-05	91-172 253-05	91-172 218-91 91-172 599-91 ●	
91-493 201-93	91-753 936-90		91-170 966-05	91-172 253-05	91-172 218-91	
91-050 544-21	91-053 988-91	91-050 966-91	91-170 966-05	91-172 253-05	91-170 438-91	
91-040 346-23			91-170 966-05	91-172 253-05	91-170 365-91	91-046 681-04
			91-169 990-05	91-172 253-05	91-170 365-91	

Modèle à 1 aiguille · Tipo de 1 aguja

91-170 966-05	91-170 793-11	91-170 365-91
91-170 966-05	91-170 793-11	91-170 365-91

Modèle à 1 aiguille · Tipo de 1 aguja

91-169 711-05	91-170 793-11	91-170 365-91 91-172 069-91 ●
91-169 711-05	91-170 793-11	91-170 365-91 91-178 185-91 ●
91-169 711-05	91-170 793-11	91-170 365-91 91-178 185-91 ●
91-169 711-05	91-170 793-11	91-170 365-91
91-169 711-05	91-170 793-11	91-178 185-91
91-169 711-05	91-170 793-11	91-178 185-91

Unterklassen-Ausstattung¹⁾

Subclass organization¹⁾

Unterklasse Subclass Sous-classe Subclasse	Ausführung Model Version Tipo de máquina	Nadelabstand in mm Needle gauge in mm Ecartement des aiguilles en mm Distancia entre agujas en mm	Nadelstange Needle bar Barre à aiguille Barra de aguja	Stoffschieber ⁴⁾ Feed dog Griffe Transportador inferior	Stichplatte ⁴⁾ Needle plate Plaque à aiguille Placa de aguja	Nähfuß ⁴⁾ Presser foot Pied presseur Pie prensateelas
HO-814/01-749/01 1-Nadel-Ausführung · Single-needle version						
-6/01 10 = 8; 12; 16; 20 mm	A B		91-170 272-92	91-047 860-04 ^{16/2}	91-058 536-04 ^{16/2}	91-055 941-93 ^{16/2}
-814/01-703/01-733/11;/12 1-Nadel-Ausführung · Single-needle version						
-39/21 9 = 3,5 - 6 mm	B		91-170 274-92	91-059 239-93	91-158 390-91	91-057 377-03
-39/21-960/81 9 = 3,5 - 6 mm	B		91-170 274-92	91-059 239-93	91-058 818-93	91-057 377-03
-814/01-731/11;/12 1-Nadel-Ausführung · Single-needle version						
-6/01 9 = 2,5 - 10 mm	B		91-170 274-92	91-047 606-04 ^{9/2}	91-058 294-03 ^{9/2} 9 = 2,5 + 3,0 mm 91-058 348-03 ^{9/2} 9 = 3,5 - 10 mm	91-055 235-93 ^{9/2} 9 = 2,5 - 6 mm 91-055 239-93 ^{9/2} 9 = 6,5 - 10 mm
-6/01-900/51;/71 9 = 2,5 - 10 mm	B		91-170 274-92	91-059 331-04 ^{9/2}	91-158 607-03 ^{9/2}	91-055 235-93 ^{9/2} 9 = 2,5 - 6 mm 91-055 239-93 ^{9/2} 9 = 6,5 - 10 mm
-814/01-748/56 1-Nadel-Ausführung · Single-needle version						
-6/01 (-900/51;/71)*	B		91-170 245-92	91-047 539-04 91-047 349-04 ●	91-058 235-04 91-058 408-04 ●	91-157 832-91
-814/01 2-Nadel-Ausführung · 2-needle version						
-6/01	B	1,6 - 12,8	91-172 440-93 ^{10/2} 10 = 1,6 - 3,2 mm 91-172 442-93 ^{10/2} 10 = 4 - 7,2 mm 91-172 444-93 ^{10/2} 10 = 10 - 12,8 mm	91-047 541-04 ^{10/2}	91-058 238-04 ^{10/2} 10 = 1,6 - 4,8 mm 91-058 492-04 ^{10/2} 10 = 6,4 - 7,2 mm 91-058 009-04 ^{10/2} 10 = 10 - 12,8 mm	91-054 899-93 ^{10/2}
-6/01-960/81	B	4,8; 6,4; 7,2	91-172 442-93 ^{10/2} 10 = 4,8 - 7,2 mm	91-059 379-04 ^{10/2}	91-158 849-93 ^{10/2}	91-054 899-93 ^{10/2}
-6/10	B	0,4; 0,8	91-172 364-93	91-059 042-05	91-058 730-04 ^{10/2}	
-57/01	B	4,8 - 7,2	91-172 442-93 ^{10/2}	91-047 866-04 ^{10/2}	91-058 578-04 ^{10/2}	91-055 785-93 ^{10/2}
-58/11	B	4,8 - 7,2	91-172 442-93 ^{10/2}	91-047 866-04 ^{10/2}	91-058 578-04 ^{10/2}	91-055 785-93 ^{10/2}
-61/03 ^{30/0}	B	10 - 12,8	91-172 444-93 ^{10/2}	91-047 541-04 ^{10/2}	91-058 009-04 ^{10/2}	91-492 350-03 ^{10/2}

Erläuterungen siehe Seite 10 und 11
 For explanations see pages 10 and 11
 Explications, voir pages 10 et 11
 Para las explicaciones, véanse páginas 10 y 11

Equipement des sous-classes¹⁾

Dotación de las subclases¹⁾

Apparat
Attachment
Appareil
Aparato

Träger
Bracket
Support
Soporte

Bandrollenträger
Tape reel bracket
Plateau dérouleur
Portarrollos

Kettensichgreifer
Looper
Boucleur
Garrío para punto
cadena

Nadelschutz
Needle guard
Garde-aiguille
Gardaaguja

Abdeckplatte
Cover plate
Plaque de recouvrement
Placa cubierta

Durchziehhaken
Pull-through hook
Tire-ruban
Ganchito

Modèle à 1 aiguille · Tipo de 1 aguja

			91-170 966-05	91-172 253-05	91-170 365-91	
			91-170 966-05	91-172 253-05	91-170 365-91	
			91-170 966-05	91-172 253-05	91-172 069-91	
			91-170 966-05	91-172 253-05	91-172 069-91	
			91-170 966-05	91-172 253-05	91-170 365-91	
			91-170 966-05	91-172 253-05	91-172 069-91	
			91-170 966-05	91-172 253-05	91-170 365-91	
			91-170 966-05	91-172 253-05	91-172 069-91	
91-050 545-21	91-053 988-91	91-050 966-91	91-170 966-05	91-172 253-05	91-170 438-91	
91-050 549-23			91-170 966-05	91-172 253-05	91-172 218-91 91-172 599-91 ●	
91-041 398-23	91-753 936-90		91-170 966-05	91-172 253-05	91-172 218-91 91-172 599-91 ●	
91-493 201-93	91-753 936-90		91-170 966-05	91-172 253-05	91-172 218-91	
91-050 544-21	91-053 988-91	91-050 966-91	91-170 966-05	91-172 253-05	91-170 438-91	
91-040 346-23			91-170 966-05	91-172 253-05	91-170 365-91	91-046 681-04
			91-169 990-05	91-172 253-05	91-170 365-91	

Modèle à 1 aiguille · Tipo de 1 aguja

91-170 966-05	91-170 793-11	91-170 365-91
91-170 966-05	91-170 793-11	91-170 365-91

Modèle à 1 aiguille · Tipo de 1 aguja

91-169 711-05	91-170 793-11	91-170 365-91 91-172 069-91 ●
91-169 711-05	91-170 793-11	91-170 365-91 91-178 185-91 ●
91-169 711-05	91-170 793-11	91-170 365-91 91-178 185-91 ●
91-169 711-05	91-170 793-11	91-170 365-91
91-169 711-05	91-170 793-11	91-178 185-91
91-169 711-05	91-170 793-11	91-178 185-91

Unterklassen-Ausstattung¹⁾

Subclass organization¹⁾

Unterklass Subclass Sous-classe Subclase	Ausführung Model Version Tipo de máquina	Nadelabstand in mm Needle gauge in mm Ecartement des aiguilles en mm Distancia entre agujas en mm	Nadelstange Needle bar Barre à aiguille Barra de aguja	Stoffschieber ⁴⁾ Feed dog Cnrite Transportador inferior	Stichplatte ⁴⁾ Needle plate Plaque à aiguille Placa de aguja	Nähfuß ⁴⁾ Presser foot Pied presseur Pie prensateelas
HO-814/01-749/01 1-Nadel-Ausführung · Single-needle version						
-6/01 10 = 8; 12; 16; 20 mm	A B		91-170 272-92	91-047 860-04 ^{10/2}	91-058 536-04 ^{16/2}	91-055 941-93 ^{16/2}
-814/01-703/01-733/11;/12 1-Nadel-Ausführung · Single-needle version						
-39/21 9 = 3,5 - 6 mm	B		91-170 274-92	91-059 239-93	91-158 390-91	91-057 377-03
-39/21-960/81 9 = 3,5 - 6 mm	B		91-170 274-92	91-059 239-93	91-058 818-93	91-057 377-03
-814/01-731/11;/12 1-Nadel-Ausführung · Single-needle version						
-6/01 9 = 2,5 - 10 mm	B		91-170 274-92	91-047 606-04 ^{9/2}	91-058 294-03 ^{9/2} 9 = 2,5 + 3,0 mm 91-058 348-03 ^{9/2} 9 = 3,5 - 10 mm	91-055 235-93 ^{9/2} 9 = 2,5 - 6 mm 91-055 239-93 ^{9/2} 9 = 6,5 - 10 mm
-6/01-900/51;/71 9 = 2,5 - 10 mm	B		91-170 274-92	91-059 331-04 ^{9/2}	91-158 607-03 ^{9/2}	91-055 235-93 ^{9/2} 9 = 2,5 - 6 mm 91-055 239-93 ^{9/2} 9 = 6,5 - 10 mm
-814/01-748/56 1-Nadel-Ausführung · Single-needle version						
-6/01 (-900/51;/71)*	B		91-170 245-92	91-047 539-04 91-047 349-04 ●	91-058 235-04 91-058 408-04 ●	91-157 832-91
-814/01 2-Nadel-Ausführung · 2-needle version						
-6/01	B	1,6 - 12,8	91-172 440-93 ^{10/2} 10 = 1,6 - 3,2 mm 91-172 442-93 ^{10/2} 10 = 4 - 7,2 mm 91-172 444-93 ^{10/2} 10 = 10 - 12,8 mm	91-047 541-04 ^{10/2}	91-058 238-04 ^{10/2} 10 = 1,6 - 4,8 mm 91-058 492-04 ^{10/2} 10 = 6,4 - 7,2 mm 91-058 009-04 ^{10/2} 10 = 10 - 12,8 mm	91-054 899-93 ^{10/2}
-6/01-960/81	B	4,8; 6,4; 7,2	91-172 442-93 ^{10/2} 10 = 4,8 - 7,2 mm	91-059 379-04 ^{10/2}	91-158 849-93 ^{10/2}	91-054 899-93 ^{10/2}
-6/10	B	0,4; 0,8	91-172 364-93	91-059 042-05	91-058 730-04 ^{10/2}	
-57/01	B	4,8 - 7,2	91-172 442-93 ^{10/2}	91-047 866-04 ^{10/2}	91-058 578-04 ^{10/2}	91-055 785-93 ^{10/2}
-58/11	B	4,8 - 7,2	91-172 442-93 ^{10/2}	91-047 866-04 ^{10/2}	91-058 578-04 ^{10/2}	91-055 785-93 ^{10/2}
-61/03 ^{30/0}	B	10 - 12,8	91-172 444-93 ^{10/2}	91-047 541-04 ^{10/2}	91-058 009-04 ^{10/2}	91-492 350-03 ^{10/2}

Erläuterungen siehe Seite 10 und 11
For explanations see pages 10 and 11
Explications, voir pages 10 et 11
Para las explicaciones, véanse páginas 10 y 11

Equipement des sous-classes¹⁾

Dotación de las subclases¹⁾

Appareil Attachement Adreito	Träger Support Soporte	Stoffschnitz Material für die Quadratbord Güte topfe	Brennstoffe Material für Flüssigbrennstoff Portarablos	Kopfschleife mit Zwischenrahmen für die reineinbauelement Plaque frontale avec intermédiaire Placa frontal con marco intermedio	Kettenschleife Looper Cadenas Cadenas cadena	Kettenschleife, vom Looper trenn Garito deslindado para punto cadena	Kettenschleife, hinten Looper, rear Boucle arrière Cadenas para punto cadena	Metallblech Metalsheet Garito alfiler Garita alfiler	Abdeckplatte Cover plate Plaque de recouvrement Placa cubierta	Messer Corte Cuchara
Modèle à 1 aiguille · Tipo de 1 aguja										
	91-170 420-91			91-172 221-01				91-172 253-05		91-171 887-05 [11] 91-171 888-05 [12]
Modèle à 1 aiguille · Tipo de 1 aguja										
91-168 061-23				91-170 966-05				91-172 253-05	91-176 538-91	91-170 440-05 91-176 537-01
91-168 061-23				91-170 966-05				91-172 253-05	91-176 538-91	91-170 440-05 91-176 537-01
Modèle à 1 aiguille · Tipo de 1 aguja										
				91-170 966-05				91-172 253-05	91-170 410-93 [17] [18] = 2,5 + 3 mm 91-170 270-93 [17] [18] = 3,5 - 10 mm	91-169 395-04 x 7 [19] = 2,5 - 6 mm 91-170 660-04 x 9 [19] = 7 - 10 mm
				91-170 966-05				91-172 253-05	91-176 096-93 [17] [18] = 2,5 - 6 mm 91-170 660-04 x 9 [19] = 7 - 10 mm	91-169 395-04 x 7 [19] = 2,5 - 6 mm 91-170 660-04 x 9 [19] = 7 - 10 mm
Modèle à 1 aiguille · Tipo de 1 aguja										
				91-170 966-05				91-172 253-05	91-170 365-91 91-172 068-91 ●	
Modèle à 2 aiguilles · Tipo de 2 agujas										
					91-169 863-05 [19] = 1,6 mm 91-169 864-05 [19] = 2,4 mm 91-169 865-05 [19] = 3,2 mm 91-169 866-05 [19] = 4,8 mm 91-169 867-05 [19] = 6,4 mm 91-169 868-05 [19] = 7,2 mm 91-169 869-05 [19] = 10 mm 91-169 870-05 [19] = 12,8 mm	91-169 873-05 [19] = 1,6 mm 91-169 874-05 [19] = 2,4 mm 91-169 875-05 [19] = 3,2 mm 91-169 876-05 [19] = 4,8 mm 91-169 877-05 [19] = 6,4 mm 91-169 878-05 [19] = 7,2 mm 91-169 879-05 [19] = 10 mm 91-169 880-05 [19] = 12,8 mm	91-172 198-05 [19] [19] = 1,6 - 6,4 mm 91-172 575-05 [19] [19] = 7,2 - 10 mm 91-172 201-05 [19] [19] = 11,2 - 12,8 mm	91-170 365-91 [19] = 1,6 - 4,8 mm 91-172 160-91 [19] = 6,4 - 7,2 mm 91-169 922-91 [19] = 10 - 12,8 mm		
					91-169 868-05 [19] = 4,8 mm 91-169 867-05 [19] = 6,4 mm 91-169 866-05 [19] = 7,2 mm	91-169 878-05 [19] = 4,8 mm 91-169 877-05 [19] = 6,4 mm 91-169 876-05 [19] = 7,2 mm	91-172 198-05 [19] [19] = 4,8 - 6,4 mm 91-172 575-05 [19] [19] = 7,2 mm	91-170 365-91 [19] = 4,8 mm 91-172 160-91 [19] = 6,4, 7,2 mm		
					91-172 573-05 [19] = 0,4 mm 91-170 368-05 [19] = 0,8 mm	91-169 872-05 [19] = 0,8 mm	91-172 202-05	91-170 365-91		
91-056 962-93					91-169 866-05 [19] = 4,8 mm 91-169 867-05 [19] = 6,4 mm 91-169 868-05 [19] = 7,2 mm	91-169 876-05 [19] = 4,8 mm 91-169 877-05 [19] = 6,4 mm 91-169 878-05 [19] = 7,2 mm	91-172 198-05 [19] [19] = 4,8 - 6,4 mm 91-172 575-05 [19] [19] = 7,2 mm	91-172 160-91		
91-056 977-93					91-169 866-05 [19] = 4,8 mm 91-169 867-05 [19] = 6,4 mm 91-169 868-05 [19] = 7,2 mm	91-169 876-05 [19] = 4,8 mm 91-169 877-05 [19] = 6,4 mm 91-169 878-05 [19] = 7,2 mm	91-172 198-05 [19] [19] = 4,8 - 6,4 mm 91-172 575-05 [19] [19] = 7,2 mm	91-176 051-91		
91-043 408-23	91-040 862-90	91-169 483-91	91-050 112-91	91-168 481-91 91-172 583-45	91-169 869-05 [19] = 10 mm 91-169 491-05 [19] = 11,2 mm 91-169 870-05 [19] = 12,8 mm	91-169 879-05 [19] = 10 mm 91-169 492-05 [19] = 11,2 mm 91-169 880-05 [19] = 12,8 mm	91-172 575-05 [19] [19] = 10 mm 91-172 201-05 [19] [19] = 11,2 - 12,8 mm	91-169 922-91		

Unterklassen-Ausstattung¹⁾

Subclass organizations¹⁾

Equipement des sous-classes¹⁾

Dotación de las subclases¹⁾

Subclases Sous-classes Subclase	Ausführung Version Versión Tipo de máquina	Neckband in mm Neckband gauge in mm Banda en mm Distancia entre agujas en mm	Nadelstange Needle bar Barras de aguja	Stitchfeeder Feed dog Transportador inferior	Stitchplate Needle plate Plaque à aiguille Placa de aguja	Stitchplate Needle plate Plaque à aiguille Placa de aguja	Stitchplate Needle plate Plaque à aiguille Placa de aguja	Träger Bracket Support Soporte	Spannvorrichtung Presser Prensa Portarrollos	Verriegelung Zuschüßer Face plate Plaque avant Placa frontal Placa frontal con mecanismo interno	Stitching Tape guide Guide-bande Guía de cinta	Bandführung Tape guide Guía de cinta Cubichita
314/01	2-Nadel-Ausführung · 2-needle version							Modèle à 2 aiguilles · Tipo de 2 agujas				
9/01	B 2,4-7,2	91-172 440-93 [197] [19] = 2,4-3,2 mm 91-172 442-93 [197] [19] = 4-7,2 mm	91-047 541-04 [197]	91-058 238-04 [197] [19] = 2,4-4,8 mm 91-058 492-04 [197] [19] = 6,4-7,2 mm	91-057 074-93 [9]							
2/12 [197]	A; B 10-12,8	91-172 444-93 [197]	91-047 541-04 [197]	91-058 009-04 [197]	91-492 350-03 [197]	91-041 906-23	91-753 938-90					
09/02-905/... [197]	A; B 12,8	91-172 444-93 [197]	91-047 541-04 [197]	91-058 009-04 [197]	91-054 899-93 [197]	91-056 132-93 91-056 128-93	91-168 461-91 91-172 583-45					
314/01-733/11; /12	2-Nadel-Ausführung · 2-needle version							Modèle à 2 aiguilles · Tipo de 2 agujas				
7/31	B 4,0	91-172 442-93 [197]	91-047 721-04	91-058 300-04	91-055 272-93	91-050 545-21						
9/31	B 4,0	91-172 442-93 [197]	91-047 721-04	91-058 300-04	91-055 272-93	91-050 544-21						
314/01-748/56	2-Nadel-Ausführung · 2-needle version							Modèle à 2 aiguilles · Tipo de 2 agujas				
/01	B 4,8-12,8	91-172 442-93 [197] [19] = 4,8-7,2 mm 91-172 444-93 [197] [19] = 10-12,8 mm	91-047 541-04 [197]	91-058 238-04 [197] [19] = 4,8 mm 91-058 492-04 [197] [19] = 6,4-7,2 mm 91-058 009-04 [197] [19] = 10-12,8 mm	91-157 968-03 [197] [19] = 4,8 + 6,4 mm 91-155 344-03 [197] [19] = 7,2-12,8 mm							
10-814/02	2-Nadel-Ausführung · 2-needle version							Modèle à 2 aiguilles · Tipo de 2 agujas				
5/02	AN 3,5 1,8-2,8	91-170 258-91	91-059 257-05	91-158 300-05 [19] = 1,8-2 mm 91-158 301-05 [19] = 2,4-2,8 mm	91-058 149-04 [197]	91-055 042-91 [9] [19] = 1,8 mm 91-055 044-91 [9] [19] = 2 mm 91-055 046-91 [9] [19] = 2,4 mm 91-055 048-91 [9] [19] = 2,8 mm						
5/02-900/71	AN 3,5 BN 3,5 1,8-2,8	91-178 035-91	91-059 257-05	91-158 300-05 [19] = 1,8-2 mm 91-158 301-05 [19] = 2,4-2,8 mm	91-058 149-04 [197]	91-055 042-91 [9] [19] = 1,8 mm 91-055 044-91 [9] [19] = 2 mm 91-055 046-91 [9] [19] = 2,4 mm 91-055 048-91 [9] [19] = 2,8 mm						
314/06	2-Nadel-Ausführung · 2-needle version							Modèle à 2 aiguilles · Tipo de 2 agujas				
1/05	B 4,5; 6,0	91-172 449-93 [197]	91-047 742-04 [19] = 4,5 mm 91-047 722-04 [19] = 6 mm	91-058 203-04 [19] = 4,5 mm 91-058 302-04 [19] = 6 mm	91-055 354-03 [197]	91-056 532-91	91-168 461-91 91-172 583-45	91-056 206-93				
4/01	B 4,5; 6,0	91-172 449-93 [197]	91-047 742-04 [19] = 4,5 mm 91-047 722-04 [19] = 6 mm	91-058 203-04 [19] = 4,5 mm 91-058 302-04 [19] = 6 mm	91-055 355-03 [197]	91-050 332-21						

1) Erläuterungen siehe Seite 10 und 11
 1) explanations see pages 10 and 11
 1) explications, voir pages 10 et 11
 1) las explicaciones, véanse páginas 10 y 11

Messer
Knife
Couteau
Cuchilla

Keitensichgreifer, vorn
Looper, front
Boucleur avant
Garfio delantero
para punto cadaneta

Keitensichgreifer, mitte
Looper, centre
Boucleur derrière
Garfio centro
para punto cadaneta

Keitensichgreifer, hinten
Looper, rear
Boucleur arrière
Garfio posterior
para punto cadaneta

Nadelschutz
Needle guard
Garde-aiguille
Gardaaguja

Abdeckplatte
Cover plate
Plaque de recouvrement
Placa cubierta

91-169 864-05 $\overline{10}$ = 2,4 mm
91-169 865-05 $\overline{10}$ = 3,2 mm
91-169 866-05 $\overline{10}$ = 4,8 mm
91-169 867-05 $\overline{10}$ = 6,4 mm
91-169 868-05 $\overline{10}$ = 7,2 mm

91-169 874-05 $\overline{10}$ = 2,4 mm
91-169 875-05 $\overline{10}$ = 3,2 mm
91-169 876-05 $\overline{10}$ = 4,8 mm
91-169 877-05 $\overline{10}$ = 6,4 mm
91-169 878-05 $\overline{10}$ = 7,2 mm

91-172 198-05
 $\overline{10}$ = 2,4 - 6,4 mm
91-172 575-05
 $\overline{10}$ = 7,2 mm

91-170 365-91
 $\overline{10}$ = 2,4 - 4,8 mm
91-172 160-91
 $\overline{10}$ = 6,4 - 7,2 mm

91-169 869-05 $\overline{10}$ = 10 mm
91-169 870-05 $\overline{10}$ = 12,8 mm

91-169 879-05 $\overline{10}$ = 10 mm
91-169 880-05 $\overline{10}$ = 12,8 mm

91-172 575-05
 $\overline{10}$ = 10 mm
91-172 201-05
 $\overline{10}$ = 11,2 - 12,8 mm

91-169 922-91

91-169 870-05

91-169 880-05

91-172 201-05

91-169 922-91

91-170 416-05
91-170 440-05

91-169 865-05

91-169 876-05

91-172 198-05

91-172 765-91

91-170 416-05
91-170 440-05

91-169 865-05

91-169 876-05

91-172 198-05

91-172 765-91

91-169 866-05 $\overline{10}$ = 4,8 mm
91-169 867-05 $\overline{10}$ = 6,4 mm
91-169 868-05 $\overline{10}$ = 7,2 mm
91-169 869-05 $\overline{10}$ = 10 mm
91-169 870-05 $\overline{10}$ = 12,8 mm

91-169 876-05 $\overline{10}$ = 4,8 mm
91-169 877-05 $\overline{10}$ = 6,4 mm
91-169 878-05 $\overline{10}$ = 7,2 mm
91-169 879-05 $\overline{10}$ = 10 mm
91-169 880-05 $\overline{10}$ = 12,8 mm

91-172 198-05
 $\overline{10}$ = 4,8 - 6,4 mm
91-172 575-05
 $\overline{10}$ = 7,2 - 10,0 mm
91-172 201-05
 $\overline{10}$ = 11,2 - 12,8 mm

91-170 365-91
 $\overline{10}$ = 4,8 mm
91-172 160-91
 $\overline{10}$ = 6,4 - 7,2 mm
91-169 922-91
 $\overline{10}$ = 10 - 12,8 mm

91-170 378-05

91-172 200-05

91-170 365-91

91-170 378-05

91-172 200-05

91-172 069-91

91-169 711-05

91-170 793-11
91-172 200-05

91-169 821-91

91-169 711-05

91-170 793-11
91-172 200-05

91-169 821-91

Unterklassen-Ausstattung¹⁾

Subclass organization¹⁾

Unterklasse Subclass Sous-classe Subclase	Ausführung Model Version Tipo de máquina	Nadelabstand in mm Needle gauge in mm Écartement des aiguilles en mm Distancia entre agujas en mm	Nadelstange Needle bar Barre à aiguille Barra de aguja	Stoffschieber ⁴ Feed dog Griffe Transportador inferior	Stichplatte ⁴ Needle plate Plaque à aiguille Placa de aguja	Nähfuß ⁴ Presser foot Pied presseur Pie prensateelas
-818/55 2-Nadel-Ausführung · 2-needle version						
-6/01	B	4,8; 6,4; 7,2	91-172 451-93 ^{10/2}	91-047 541-04 ^{10/2}	91-058 238-04 ^{10/2} ¹⁰ = 4,8 mm 91-058 492-04 ^{10/2} ¹⁰ = 6,4; 7,2 mm	91-057 041-93 ^{10/2}
-32/01 ^{30/0}	B	4,8; 6,4; 7,2	91-172 451-93 ^{10/2}	91-047 541-04 ^{10/2}	91-058 238-04 ^{10/2} ¹⁰ = 4,8 mm 91-058 492-04 ^{10/2} ¹⁰ = 6,4; 7,2 mm	91-055 722-93 ^{10/2}
-65/01	B	4,8; 6,4; 7,2	91-172 451-93 ^{10/2}	91-047 541-04 ^{10/2}	91-058 238-04 ^{10/2} ¹⁰ = 4,8 mm 91-058 492-04 ^{10/2} ¹⁰ = 6,4; 7,2 mm	91-055 722-93 ^{10/2}
-65/01-960/11	B	4,8; 6,4; 7,2	91-172 451-93 ^{10/2}	91-059 379-04 ^{10/2}	91-158 849-93 ^{10/2}	91-055 722-93 ^{10/2}

-818/56 3-Nadel-Ausführung · 3-needle version

-65/01	BN 3,5	x2,4 x6,0	91-178 025-91	91-059 607-04	91-158 352-04 91-158 358-05 ▲	91-157 662-91
-65/01-960/11	BN 3,5	x2,4 x6,0	91-178 025-91	91-059 607-04	91-158 352-04 91-158 353-01 ▼	91-157 662-91

H-814/01-704/02-748/56 2-Nadel-Ausführung · 2-needle version

-6/01-960/14	B; C	6,4 + 7,2	91-178 073-93	91-059 264-04 ^{10/2}	91-158 323-93 ^{10/2}	91-157 543-93 ^{10/2}
--------------	------	-----------	---------------	-------------------------------	-------------------------------	-------------------------------

H-814/01-704/02-748/56 3-Nadel-Ausführung · 3-needle version

-6/01-960/14	B; C	x3,2 x3,2 x3,6 x3,6	91-178 074-93	91-059 265-04	91-158 325-93	91-157 545-93
--------------	------	------------------------	---------------	---------------	---------------	---------------

* = abweichende Teile für -900/.. sind mit (●) markiert
 = the parts marked with (●) are variants for subcl. -900/..
 = les pièces marquées d'un point (●) correspondent au modèle avec -900/..
 = las piezas marcadas con un punto (●) corresponden a modelos con -900/..

● = Teile zur -900/..
 = Parts for subcl. -900/..
 = Pièces p. la ss-cl. -900/..
 = Piezas para la subc. -900/..

⁴ = Ausführung angeben
 = Indicate model
 = Préciser la version
 = Indique el tipo de máquina

¹⁰ = Nadelabstand
 = Needle gauge
 = Écartement des aiguilles
 = Distancias entre agujas

¹⁶ = Auszackbreite
 = Pinking margin
 = Distance crantage-couture
 = Margen dentado-costura

⁵ = Nähmuster einsenden
 = Submit sewing sample
 = Joindre échantillons de couture
 = Enviar muestra de costura

^{10/2} = Nadelabstand bei Bestellung angeben
 = State needle gauge on order
 = Indiquer écartement des aiguilles à la commande
 = Indique en los pedidos la distancia entre agujas

^{16/2} = Auszackbreite bei Bestellung angeben
 = State pinking margin on order
 = Indiquer la distance couture-crantage à la commande, S.V.P.
 = Indique margen dentado-costura en los pedidos

⁹ = Schneideabstand
 = Trimming margin
 = Distance de coupe
 = Margen de corte

^{12/2} = Absteppbreite bei Bestellung angeben
 = Indicate stitching margin on order
 = Indiquer le relarge de couture à la commande
 = Indique el margen de costura en los pedidos

¹⁹ = Biesenbreite
 = Cording width
 = Largeur de la nervure
 = Anchura de la alforza

^{9/2} = Schneideabstand bei Bestellung angeben
 = State trimming margin on order
 = Indiquer la distance de coupe à la commande
 = Indique el margen de corte en todos los pedidos

¹³ = Saumbreite
 = Hem width
 = Largeur de l'ourlet
 = Anchura de dobladillo

^{19/2} = Biesenbreite bei Bestellung angeben
 = State cording width on order
 = Indiquer la largeur de nervure à la commande, S.V.P.
 = Indique la anchura de las nervuras en los pedidos

Equipement des sous-classes¹⁾

Dotación de las subclases¹⁾

Stoffanschlag Material guide Guide-bord Guia tope	Kettensichgreifer, vorn Looper, front Boucleur avant Garfo delantero para punto cadeneta	Kettensichgreifer, mitte Looper, centre Boucleur derrière Garfo centro para punto cadeneta	Kettensichgreifer, hinten Looper, rear Boucleur arrière Garfo posterior para punto cadeneta	Nadelschutz Needle guard Garde-aiguille Gardaaguja	Abdeckplatte Cover plate Plaque de recouvrement Placa cubierta
--	--	--	---	---	---

Modèle à 2 aiguilles · Tipo de 2 agujas

	91-169 866-05 $\overline{10}$ = 4,8 mm 91-169 867-05 $\overline{10}$ = 6,4 mm 91-169 868-05 $\overline{10}$ = 7,2 mm		91-169 876-05 $\overline{10}$ = 4,8 mm 91-169 877-05 $\overline{10}$ = 6,4 mm 91-169 878-05 $\overline{10}$ = 7,2 mm	91-172 124-05	91-170 365-91 $\overline{10}$ = 4,8 mm 91-172 160-91 $\overline{10}$ = 6,4 - 7,2 mm
91-055 771-01	91-169 866-05 $\overline{10}$ = 4,8 mm 91-169 867-05 $\overline{10}$ = 6,4 mm 91-169 868-05 $\overline{10}$ = 7,2 mm		91-169 876-05 $\overline{10}$ = 4,8 mm 91-169 877-05 $\overline{10}$ = 6,4 mm 91-169 878-05 $\overline{10}$ = 7,2 mm	91-172 124-05	91-170 365-91 $\overline{10}$ = 4,8 mm 91-172 160-91 $\overline{10}$ = 6,4 - 7,2 mm
91-055 771-01	91-169 866-05 $\overline{10}$ = 4,8 mm 91-169 867-05 $\overline{10}$ = 6,4 mm 91-169 868-05 $\overline{10}$ = 7,2 mm		91-169 876-05 $\overline{10}$ = 4,8 mm 91-169 877-05 $\overline{10}$ = 6,4 mm 91-169 878-05 $\overline{10}$ = 7,2 mm	91-172 124-05	91-170 365-91 $\overline{10}$ = 4,8 mm 91-172 160-91 $\overline{10}$ = 6,4 - 7,2 mm
91-055 771-01	91-169 866-05 $\overline{10}$ = 4,8 mm 91-169 867-05 $\overline{10}$ = 6,4 mm 91-169 868-05 $\overline{10}$ = 7,2 mm		91-169 876-05 $\overline{10}$ = 4,8 mm 91-169 877-05 $\overline{10}$ = 6,4 mm 91-169 878-05 $\overline{10}$ = 7,2 mm	91-172 124-05	91-158 847-91

Modèle à 3 aiguilles · Tipo de 3 agujas

91-176 980-05	91-176 981-05	91-176 982-05	91-178 022-05	91-178 046-91
91-176 980-05	91-176 981-05	91-176 982-05	91-178 022-05	91-178 046-91

Modèle à 2 aiguilles · Tipo de 2 agujas

91-169 867-05 $\overline{10}$ = 6,4 mm 91-169 868-05 $\overline{10}$ = 7,2 mm	91-169 877-05 $\overline{10}$ = 6,4 mm 91-169 878-05 $\overline{10}$ = 7,2 mm	91-172 198-05 $\overline{10/2}$	91-170 365-91
--	--	---------------------------------	---------------

Modèle à 3 aiguilles · Tipo de 3 agujas

91-176 980-05	91-176 981-05	91-176 982-05	91-176 985-05	91-170 365-91
---------------	---------------	---------------	---------------	---------------

1) Die Liste enthält nur Nähwerkzeuge und Apparate. Beim Umbau in eine andere Unterklasse oder Ausführung können auch noch Maschinenteile erforderlich werden. Geben Sie also bei Bestellungen die genaue Bezeichnung der vorhandenen und der gewünschten Ausführung bekannt.

1) This list contains sewing parts and attachments only. When converting to another subclass or version, machine parts may also be required. When ordering please therefore indicate exactly the existing version and the one required.

1) Cette liste ne contient que les organes de couture et les guides. En cas de transformation en une sous-classe ou variante différente, certaines pièces de machine supplémentaires pourront devenir nécessaires. En cas de commande, prière de toujours indiquer par conséquent les variantes disponibles et souhaitées.

1) Esta lista sólo contiene elementos de costura y aparatos. Siempre que haya que transformar la máquina en otro tipo o subclase, es posible que se necesiten también piezas de máquina, por lo que deberá indicarse en los pedidos el tipo exacto de que se dispone y el deseado.

$\overline{30/0}$ = Nicht mehr im Programm jedoch Ersatzteile lieferbar
= No longer part of production range; substitute available
= Rayé du programme; pièces détachées toutefois livrables
= Fuera de programa; las piezas de recambio, no obstante, se siguen suministrando.

$\overline{74}$ = Auszackmesser für -749/01
= Pinking knife for -749/01
= Couteau-cranteur pour -749/01
= Cuchilla de dentar para -749/01

▲ = Abdeckwinkel
= Covering angle
= Pièce de recouvrement
= Piza de recubrimiento

$\overline{80}$ = wahlweise
= optional
= en option
= discrecional

$\overline{76}$ = Untermesser für -749/01
= Lower knife for -749/01
= Couteau inférieur pour -749/01
= Cuchilla inferior para -749/01

▼ = Messer
= Knife
= Couteau
= Cuchilla

Unterklassen-Übersicht/Table of subclasses/Table des sous-classes/Tabla de subclasses

91-170 245-92

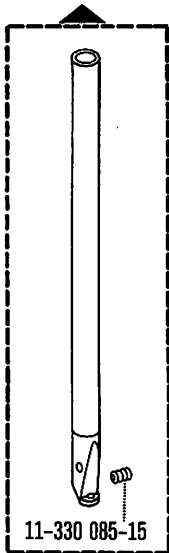

11-330 085-15

- 814/01-6/01 (-900/51; /71)
- 814/01-6/02 (-900/..)
- 814/01-6/10 (-900/51; /71)
- 814/01-17/31
- 814/01-19/01 (-900/51; /71)
- 814/01-19/05 (-900/51; /71)
- 814/01-19/05-920/11
- 814/01-39/31
- 814/01-193/01
- 814/01-944/01
- 814/01-748/56-6/01 (-900/51; /71)

91-170 258-91

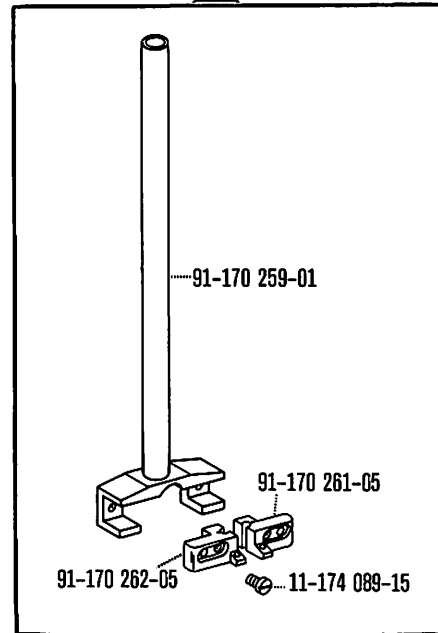

91-170 259-01

91-170 261-05

91-170 262-05

11-174 089-15

HO-814/02-45/02

91-170 272-92

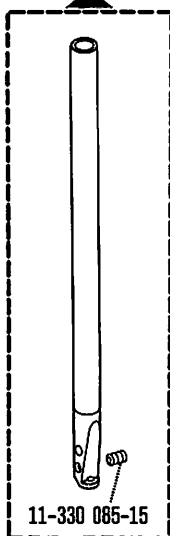

11-330 085-15

91-170 274-92

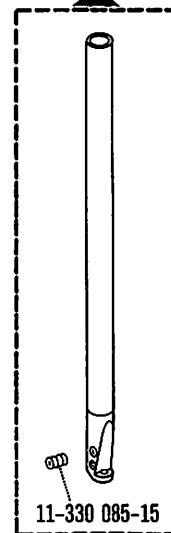

11-330 085-15

R-814/01-6/02 (-960/81)
HO-814/01-749/01-6/01

-814/01-703/01-733/11; /12-39/21 (-960/81)
-814/01-731/11; /12-6/01 (-900/51; /71)

Unterklassen-Übersicht/ Table of subclasses/ Table des sous-classes/ Tabla de subclasses

91-172 012-92

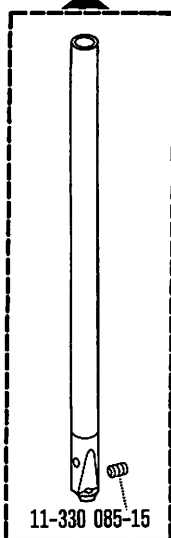

11-330 085-15

H-814/01-6/01 (-900/..) -911/..
 H-814/01-6/02 (-900/51; /71) -911/03; /05
 H-814/01-6/10 (-900/51; /71) -911/03; /05
 H-814/01-6/12 (-900/51; /71) -911/03; /05

91-172 364-93

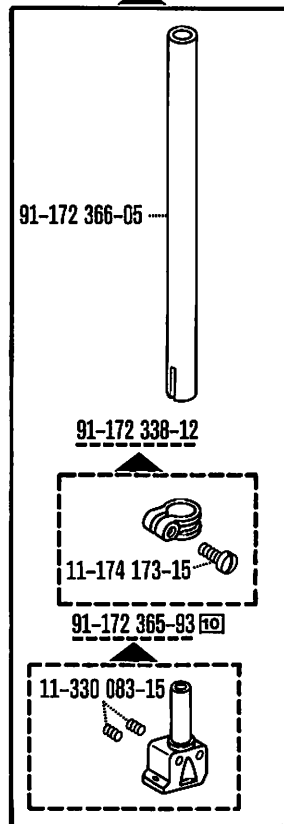

91-172 366-05

91-172 338-12

11-174 173-15

91-172 365-93

11-330 083-15

-814/01-6/10

91-172 440-93

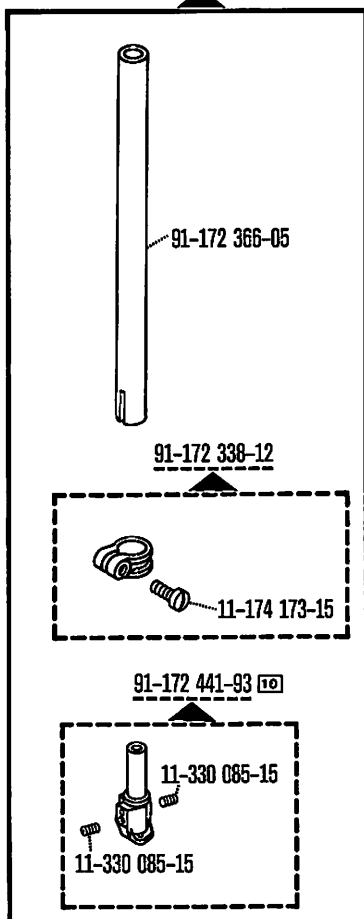

91-172 366-05

91-172 338-12

11-174 173-15

91-172 441-93

11-330 085-15

11-330 085-15

-814/01-6/01
 -814/01-69/01

91-172 442-93

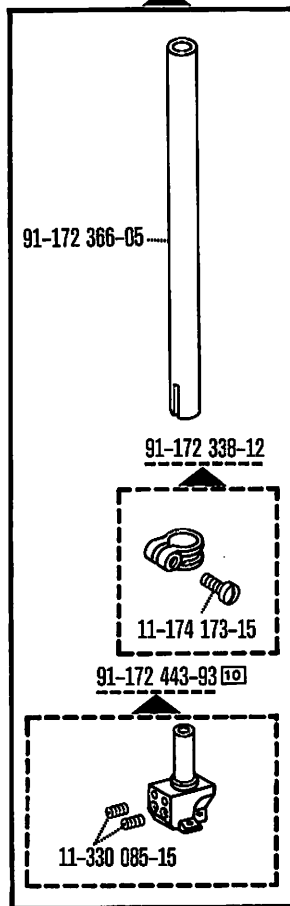

91-172 366-05

91-172 338-12

11-174 173-15

91-172 443-93

11-330 085-15

-814/01-6/01 (-960/81)
 -814/01-57/01
 -814-01/58/11
 -814/01-69/01
 -814/01-733/11; /12-17/31
 -814/01-733/11; /12-39/31
 -814/01-748/56-6/01

Unterklassen-Übersicht/Table of subclasses/Table des sous-classes/Tabla de subclasses

91-172 444-93 10/2



91-172 366-05

91-172 338-12



11-174 173-15

91-172 445-93 10

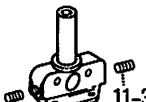

11-330 085-15

11-330 085-15

-814/01-6/01
 -814/01-61/03
 -814/01-82/12
 -814/01-309/02-805/..
 -814/01-748/56-6/01

91-172 449-93 10/2



91-172 366-05

91-172 338-12



11-174 173-15

91-172 450-93 10



11-330 085-15

11-330 085-15

-814/06-61/05
 -814/06-94/01

91-172 451-93 10/2



91-172 335-05

91-172 338-12



11-174 173-15

91-172 452-93 10

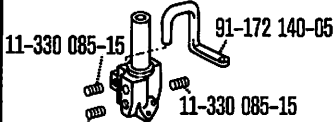

11-330 085-15

91-172 140-05

11-330 085-15

11-330 085-15

-818/55-6/01
 -818/55-32/01
 -818/55-65/01 (-980/11)

91-178 025-91



91-172 335-05

91-172 338-12



11-174 173-15

91-178 001-92

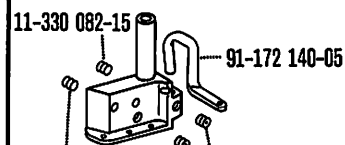

11-330 082-15

91-172 140-05

11-330 082-15

11-330 082-15

11-330 082-15

-818/56-65/01 (-980/11)

Unterklassen-Übersicht/ Table of subclasses/ Table des sous-classes/ Tabla de subclasses

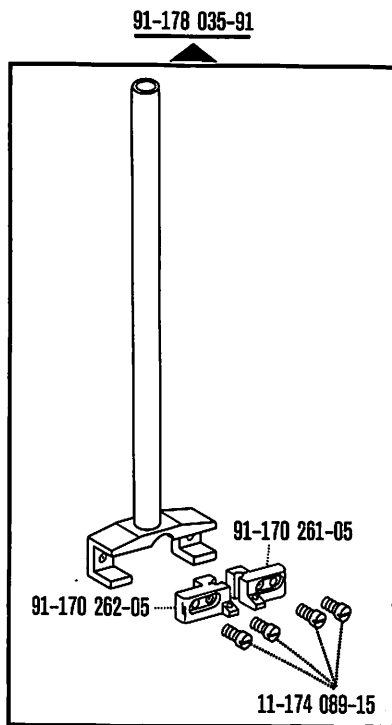

H0-814/02-45/02-900/71

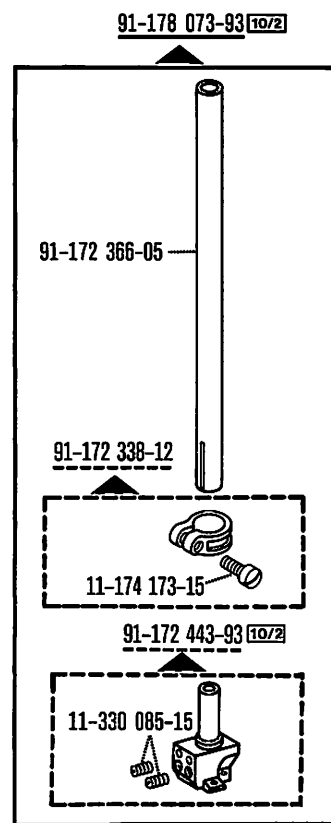

H-814/01-704/02-748/56-6/01-960/14

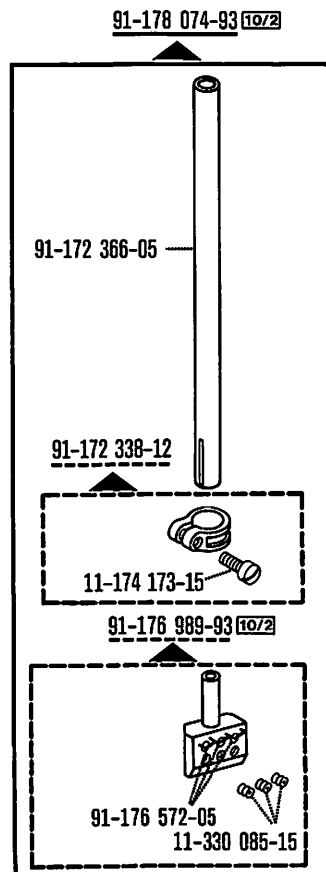

H-814/01-704/02-748/56-6/01-960/14

Unterklassen-Übersicht/Table of subclasses/Table des sous-classes/Tabla de subclasses

91-047 319-05

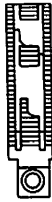

91-047 349-04



91-047 384-05



H-814/01-6/02 (-900/51; /71) -911/03; /05

-814/01-6/01-900/51; /71
H-814/01-6/01 (-900/..) -911/..
-814/01-748/56-6/01 (-900/51; /71)

-814/01-6/02
-814/01-6/10
R-814/01-6/02

91-047 539-04

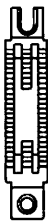

-814/01-6/01
R-814/01-6/02-980/81
-814/01-748/56-6/01 (-900/51; /71)

91-047 541-04

= 0,8-1,6 mm

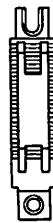

= 2,4-7,2 mm

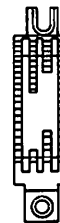

= 10,0-12,8 mm

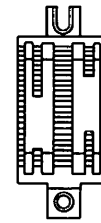

-814/01-6/01
-814/01-61/03
-814/01-69/01
-814/01-82/12

-814/01-309/02-905/..
-814/01-748/56-6/01
-818/55-6/01
-818/55-32/01
-818/55-65/01

91-047 582-05



-814/01-6/02-900/..

91-047 606-04

= 2,5-3,4 mm



= 3,5-5,9 mm

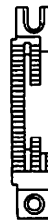

= 6,0-7,9 mm

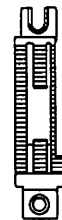

= 8,0-10,0 mm

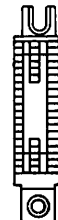

-814/01-731/11; /12-6/01

91-047 608-04

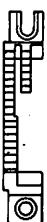

-814/01-944/01

91-047 628-04

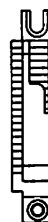

-814/01-17/31
-814/01-39/31

91-047 721-04



-814/01-733/11; /12-17/31
-814/01-733/11; /12-39/31

Unterklassen-Übersicht/ Table of subclasses/ Table des sous-classes/ Tabla de subclasses

91-047 722-04 



-814/06-61/05
-814/06-94/01

91-047 742-04 

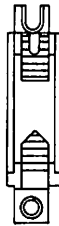

-814/06-61/05
-814/06-94/01

91-047 830-05



-814/01-19/01 (-900/51; /71)
-814/01-19/05 (-900/51; /71)
-814/01-19/05-920/11

91-047 833-05



-814/01-6/10-900/51; /71
H-814/01-6/02 (-900/51; /71)-911/03; /05
H-814/01-6/10 (-900/51; /71)-911/03; /05
H-814/01-6/12-900/51; /71-911/03; /05

91-047 851-04 

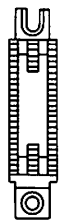

-814/01-6/01 (-900/51; /71)

91-047 860-04  

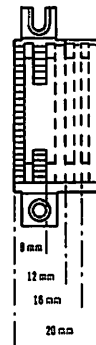

HO-814/01-749/01-6/01

91-047 866-04  

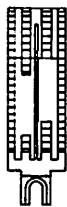

-814/01-57/01
-814/01-58/11

91-059 042-05

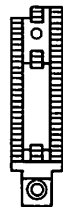

-814/01-6/10

91-059 239-93

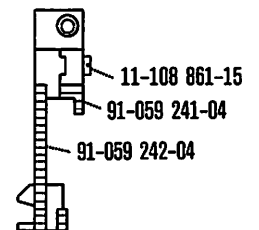

-814/01-703/01-733/11; /12-39/21 (-960/81)

91-059 257-05

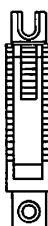

HO-814/02-45/02 (-900/71)

91-059 264-04

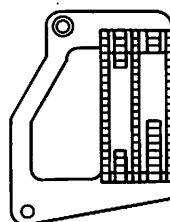

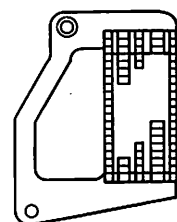

H-814/01-704/02-748/56-6/01-960/14

91-059 265-04



H-814/01-704/02-748/56-6/01-960/14

Unterklassen-Übersicht/Table of subclasses/Table des sous-classes/Tabla de subclasses

91-059 331-04  

 = 2,5 - 3,4 mm  = 3,5 - 5,9 mm  = 6,0 - 7,9 mm  = 8,0 - 10,0 mm

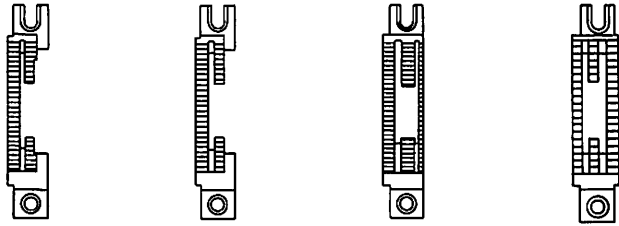

91-059 379-04 

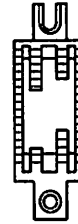

-814/01-731/11; /12-6/01-900/51; /71

-814/01-6/01-960/81
-818/55-65/01-960/11

91-059 607-04

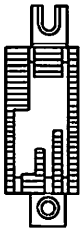



-818/56-65/01 (-960/11)

91-460 077-05



-814/01-193/01

91-058 009-04  



-814/01-82/12
-814/01-6/01 -814/01-309/02-905/..
-814/01-61/03 -814/01-748/56-6/01

91-058 155-05

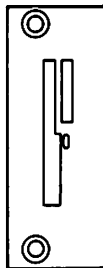

-814/01-944/01

91-058 196-05

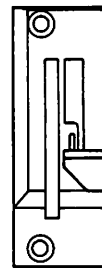

-814/01-17/31
-814/01-39/31

91-058 203-04 

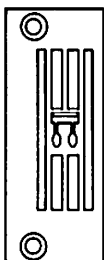





-814/08-61/05
-814/08-94/01

91-058 235-04 



-814/01-6/01
-814/01-748/56-6/01 (-900/51; /71)

91-058 238-04  
 = 1,6 mm  = 2,4-4,8 mm

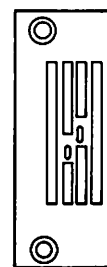
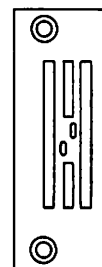



-814/01-6/01 -818/55-6/01
-814/01-69/01 -818/55-32/01
-814/01-748/56-6/01 -818/55-65/01

Unterklassen-Übersicht/ Table of subclasses/ Table des sous-classes/ Tabla de subclasses

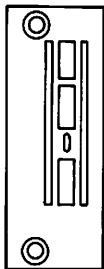
91-058 239-04 



-814/01-6/02
-814/01-6/10
R-814/01-6/02

91-058 294-03  
 = 2,5 - 3,4 mm

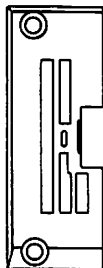

-814/01-731/11; /12-6/01

91-058 300-04 

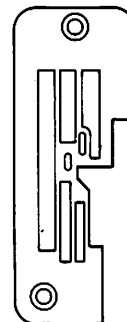



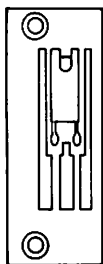

-814/01-733/11; /12-17/31
-814/01-733/11; /12-39/31

91-058 302-04 



-814/06-61/05
-814/06-94/01

91-058 348-03  
 = 3,5-5,9 mm  = 6,0-7,9 mm  = 8,0-10,0 mm

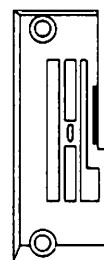
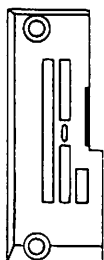

-814/01-731/11; /12-6/01

91-058 408-04 

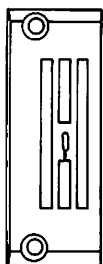

-814/01-6/01-900/51; /71
H-814/01-6/01 (-900/..) -911/..
-814/01-748/56-6/01 (-900/51; /71)

91-058 409-04 

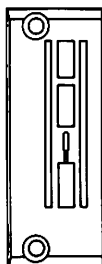

-814/01-6/02-900/..
-814/01-6/10-900/51; /71
H-814/01-6/10-911/03; /05

91-058 445-04 

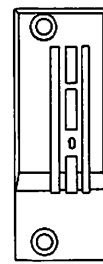

H-814/01-6/02 (-900/51; /71)-911/03; /05
H-814/01-6/10-900/51; /71-911/03; /05
H-814/01-6/12-900/51; /71-911/03; /05

91-058 455-05

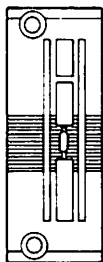

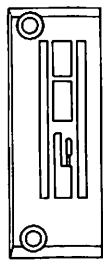

H-814/01-6/02 (-900/51; /71)-911/03; /05
H-814/01-6/10-900/51; /71-911/03; /05
H-814/01-6/12-900/51; /71-911/03; /05

91-058 484-05



H-814/01-6/02 (-900/51; /71)-911/03; /05

91-058 492-04  

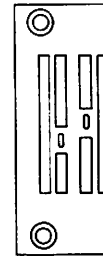

-814/01-6/01 -818/55-6/01
-814/01-69/01 -818/55-32/01
-814/01-748/56-6/01 -818/55-65/01

Unterklassen-Übersicht/ Table of subclasses/ Table des sous-classes/ Tabla de subclasses

91-058 536-04 [4] [16/2]

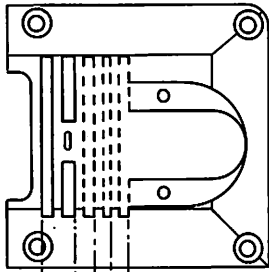

8 mm
12 mm
15 mm
20 mm

HO-814/01-749/01-6/01

91-058 578-04 [4] [10/2]



-814/01-57/01
-814/01-58/11

91-058 730-04 [4] [10/2]

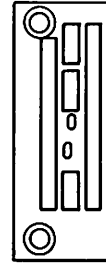

-814/01-6/10

91-058 818-93

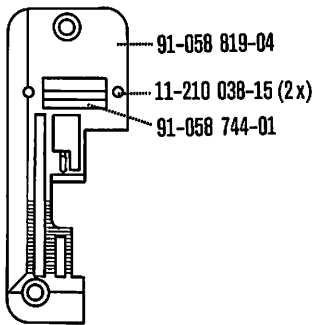

-814/01-703/01-733/11; /12-39/21-960/81

91-158 300-05

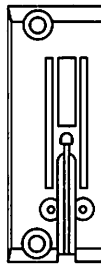

HO-814/02-45/02 (-900/71)

91-158 301-05

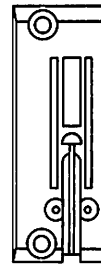

HO-814/02-45/02 (-900/71)

91-158 323-93

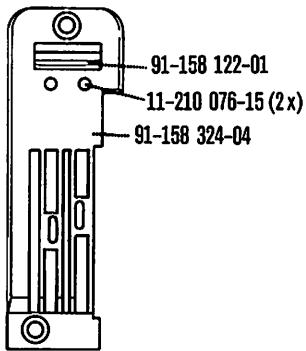

H-814/01-704/02-748/56-6/01-960/14

91-158 325-93

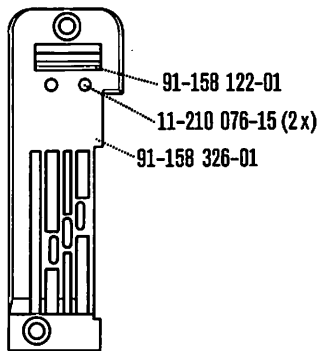

H-814/01-704/02-748/56-6/01-960/14

91-158 352-04

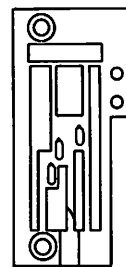

..-65/01-960/11

91-158 353-01



11-108 093-15



..-65/01

91-158 358-05

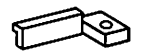

11-108 093-15

-818/56-85/01 (-960/11)

91-158 390-91

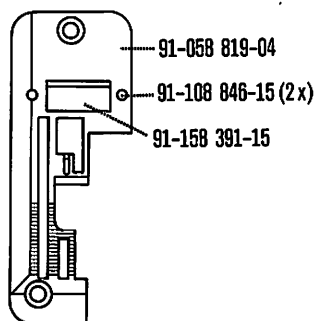

-814/01-703/01-733/11; /12-39/21

91-158 427-04 [4]



-814/01-6/01 (-900/51; /71)

91-158 595-93 [4]

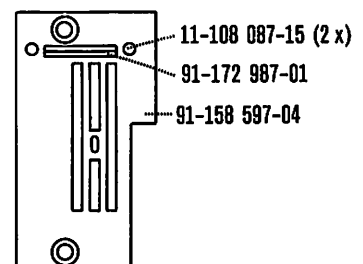

R-814/01-6/02-860/81

Unterklassen-Übersicht/ Table of subclasses/ Table des sous-classes/ Tabla de subclasses

91-158 607-03 4 9/2

9 = 2,5 - 3,4 mm

9 = 3,5 - 5,9 mm

9 = 6,0 - 7,9 mm

9 = 8,0 - 10,0 mm

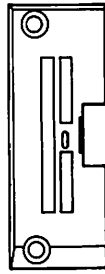

91-158 849-93 10/2

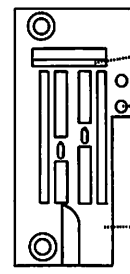

91-158 353-01

11-108 093-15

91-158 850-04

-814/01-731/11; /12-6/01-900/51; /71

-814/01-6/01-960/81

-818/55-85/01-960/11

91-460 076-05

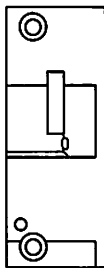

-814/01-193/01

91-058 149-04 19/2

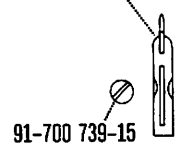

91-700 739-15

H0-814/02-45/02 (-900/71)

91-051 155-93 4

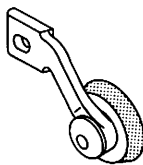

-814/01-944/01

91-054 883-91

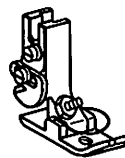

-814/01-6/02 (-900/..)

91-054 899-93 4 10/2

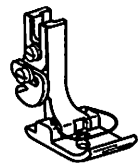

-814/01-6/01 (-960/81)

-814/01-309/02-905/..

91-054 948-01

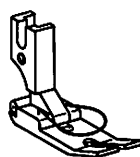

-814/01-6/01-900/51; /71
H-814/01-6/01-900/..-911/..

91-054 950-91

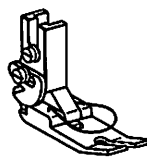

-814/01-6/01
H-814/01-6/01-911/..

91-055 040-93 4 12/2

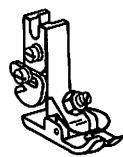

-814/01-19/01 (-900/51; /71)

-814/01-19/05 (-900/51; /71)

-814/01-19/05-920/11

Unterklassen-Übersicht/ Table of subclasses/ Table des sous-classes/ Tabla de subclasses

91-055 042-91

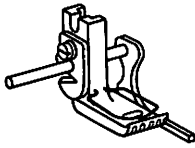

H0-814/02-45/02 (-900/71)

91-055 044-91

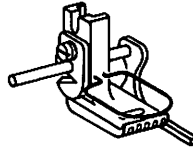

H0-814/02-45/02 (-900/71)

91-055 046-91

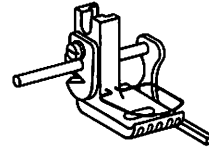

H0-814/02-45/02 (-900/71)

91-055 048-91

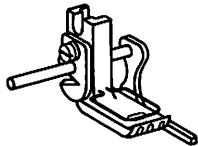

H0-814/02-45/02 (-900/71)

91-055 081-91



-814/01-17/31
-814/01-39/31

91-055 235-93 4 9/2

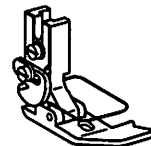

-814/01-731/11; /12-6/01 (-900/51; /71)

91-055 239-93 4 9/2

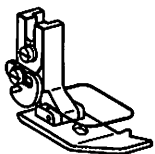

-814/01-731/11; /12-6/01 (-900/51; /71)

91-055 272-93 4

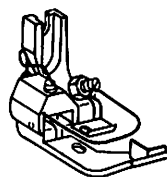

-814/01-733/11; /12-17/31
-814/01-733/11; /12-39/31

91-055 354-03 4 10/2

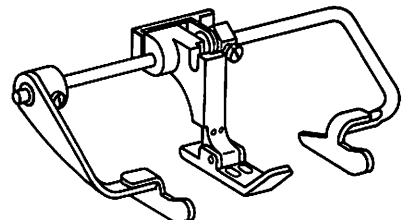

-814/06-61/05

91-055 355-03 4 10/2

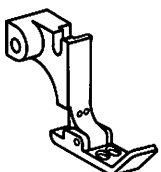

-814/06-94/01

91-055 722-93 4 10/2

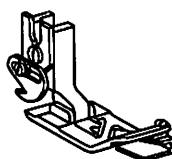

-818/55-32/01
-818/55-65/01 (-960/11)

91-055 730-91

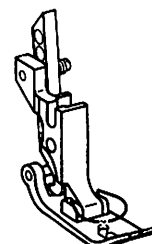

H-814/01-6/12-900/51; /71-911/03; /05

Unterklassen-Übersicht/ Table of subclasses/ Table des sous-classes/ Tabla de subclasses

91-055 782-93 

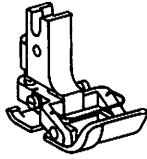

-814/01-58/11

91-055 785-93 

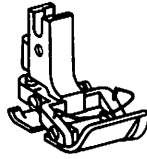

-814/01-57/01

91-055 787-01

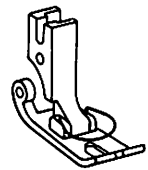

H-814/01-6/02-900/51; /71-911/03; /05

91-055 789-91

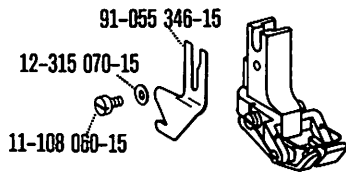

-814/01-6/10
H-814/01-6/10-911/03; /05

91-055 790-91

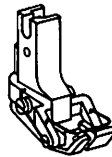

-814/01-6/10-900/51; /71
H-814/01-6/10-900/51; /71-911/03; /05

91-055 792-91

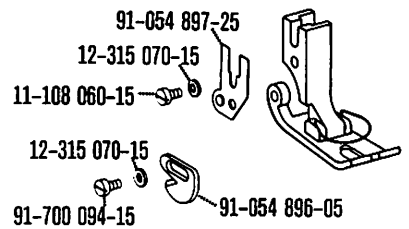

H-814/01-6/02-911/03; /05

91-055 941-93 

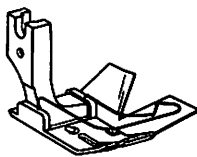

H0-814/01-749/01-6/01

91-057 041-93 

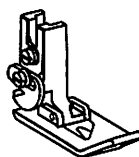

-818/55-6/01

91-057 074-93 

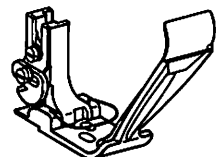

-814/01-69/01

91-057 187-93 

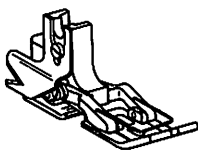

-814/01-6/10

91-057 377-03

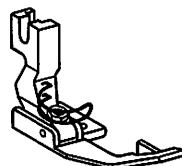

-814/01-703/01-733/11; /12-39/21 (-960/81)

91-155 344-03 

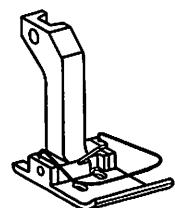

-814/01-748/56-6/01

Unterklassen-Übersicht/ Table of subclasses/ Table des sous-classes/ Tabla de subclasses

91-157 543-93 10/2

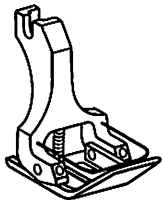

H-814/01-704/02-748/56-6/01-960/14

91-157 545-93

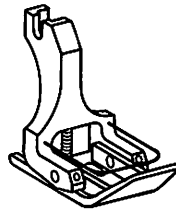

H-814/01-704/02-748/56-6/01-960/14

91-157 662-91

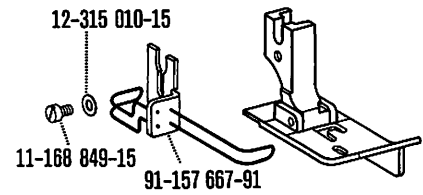

-818/56-65/01 (-960/11)

91-157 832-91

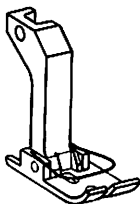

-814/01-748/56-6/01 (-900/51; /71)

91-157 968-03 10/2

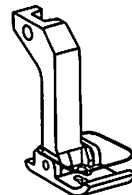

-814/01-748/56-6/01

91-157 978-91

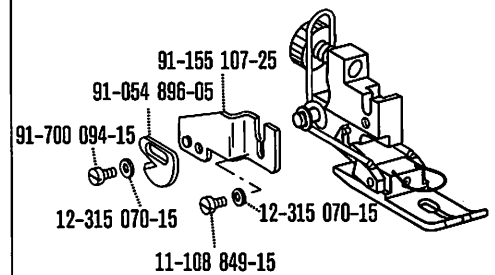

R-814/01-6/02 (-960/81)

91-460 078-01



-814/01-193/01

91-492 350-03 4 10/2

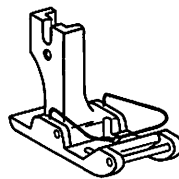

-814/01-61/03
-814/01-82/12

91-040 346-23 5



-814/01-193/01

91-041 398-23 5

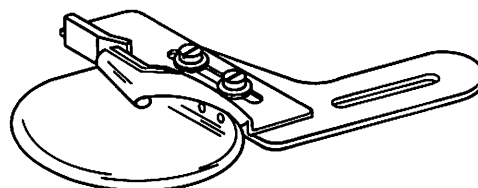

-814/01-19/05 (-900/51; /71)

Unterklassen-Übersicht/ Table of subclasses/ Table des sous-classes/ Tabla de subclases

91-041 906-23 

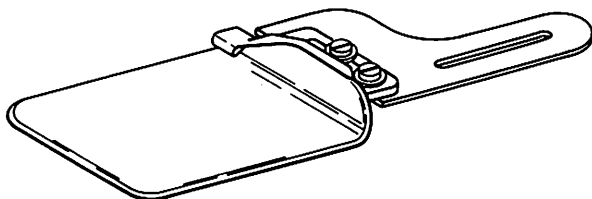

-814/01-82/12

91-043 408-23

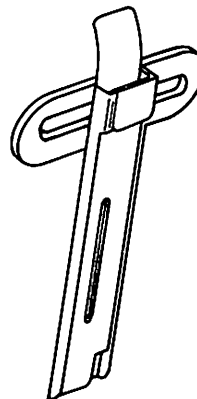

-814/01-61/03

91-050 332-21 

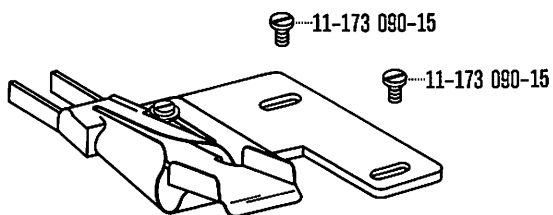

-814/06-94/01

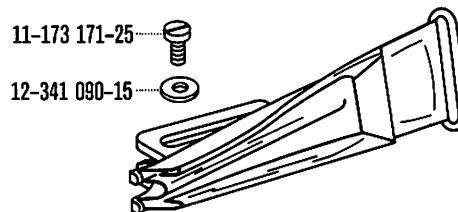

91-050 544-21 



-814/01-39/31

-814/01-733/11; /12-39/31

91-050 545-21 

(2x) 11-173 171-25 
 (2x) 12-341 090-15 

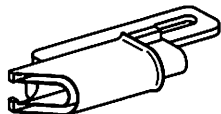

-814/01-733/11; /12-17/31

91-050 549-23 

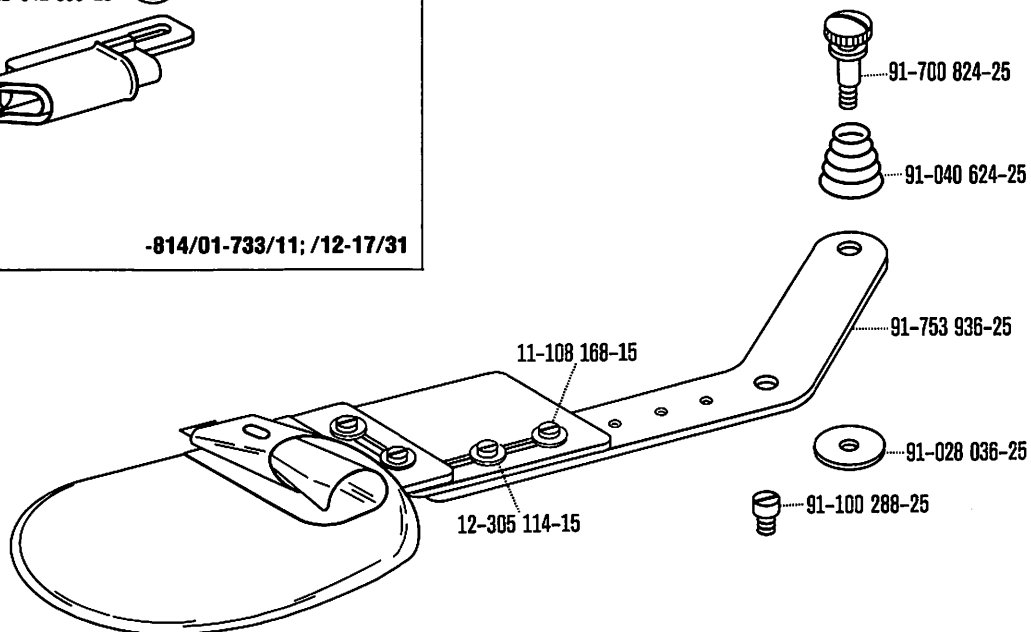

-814/01-19/01 (-900/51; /71)

Unterklassen-Übersicht/Table of subclasses/Table des sous-classes/Tabla de subclasses

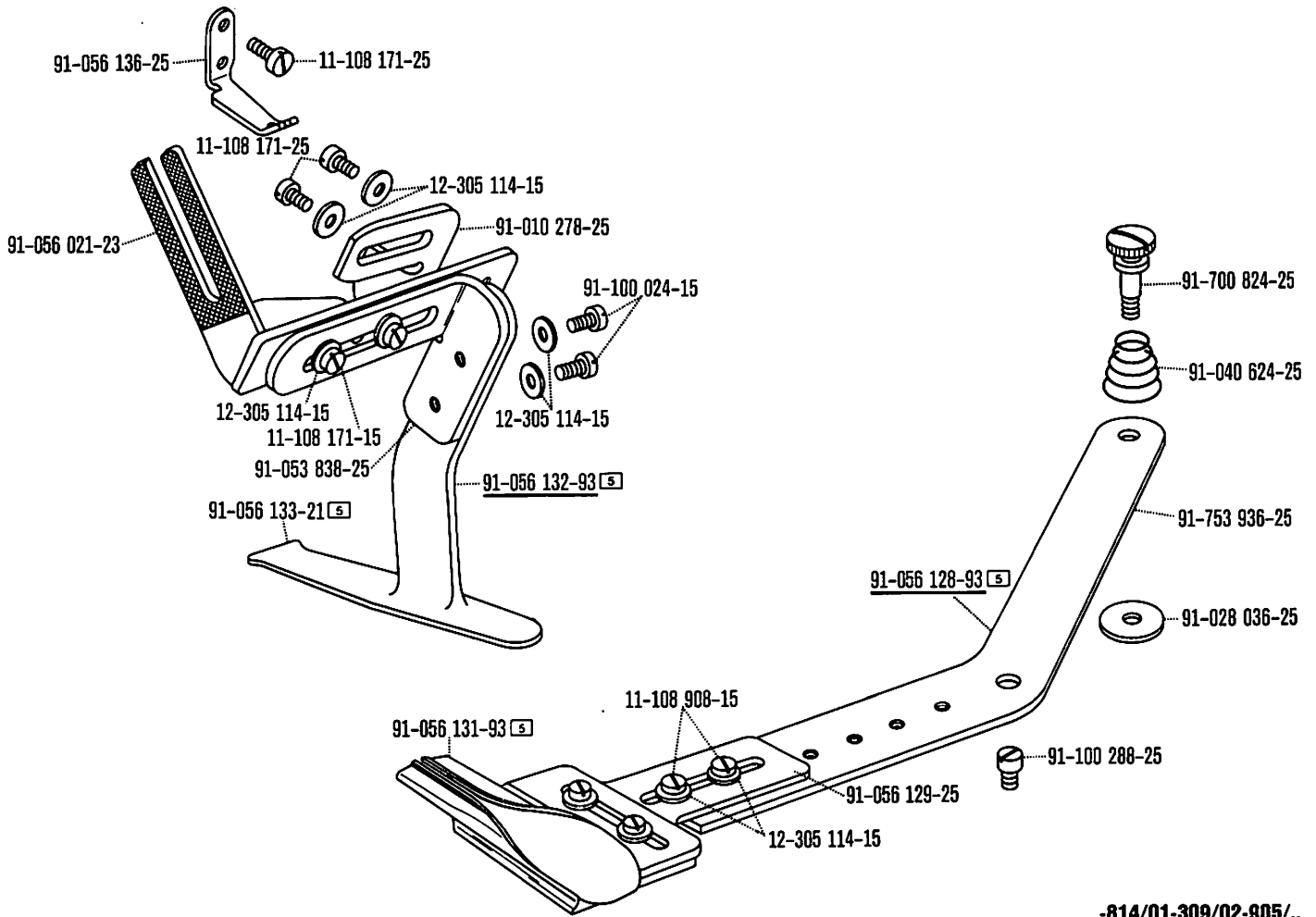

-814/01-309/02-905/..

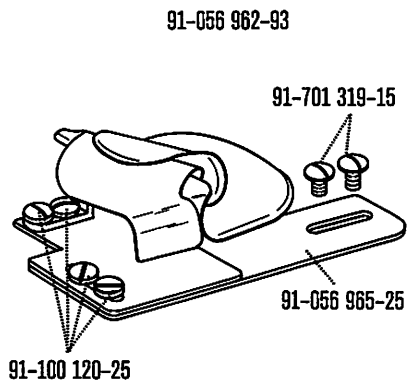

-814/01-57/01

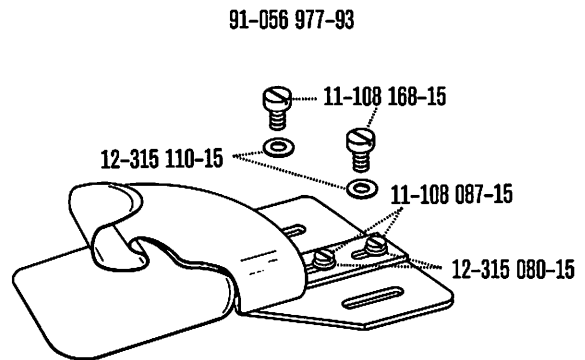

-814/01-58/11

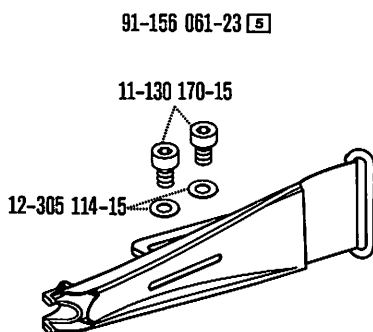

-814/01-703/01-733/11; /12-39/21 (-960/81)

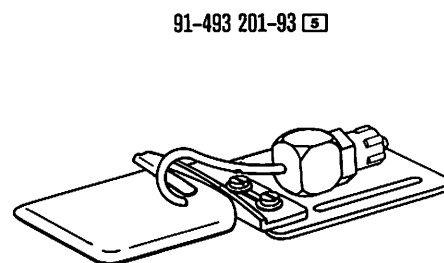

-814/01-19/05-920/11

Unterklassen-Übersicht/ Table of subclasses/ Table des sous-classes/ Tabla de subclasses

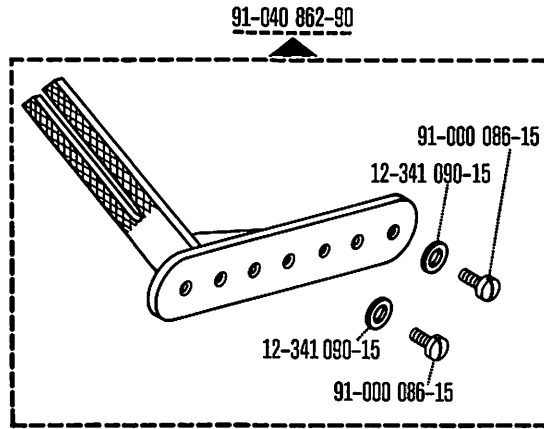

-814/01-61/03

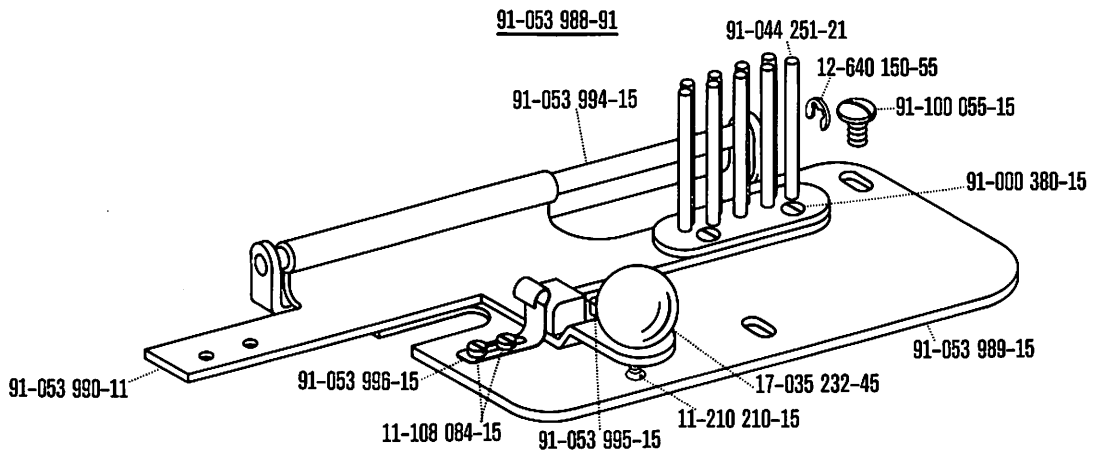

-814/01-17/31

-814/01-39/31

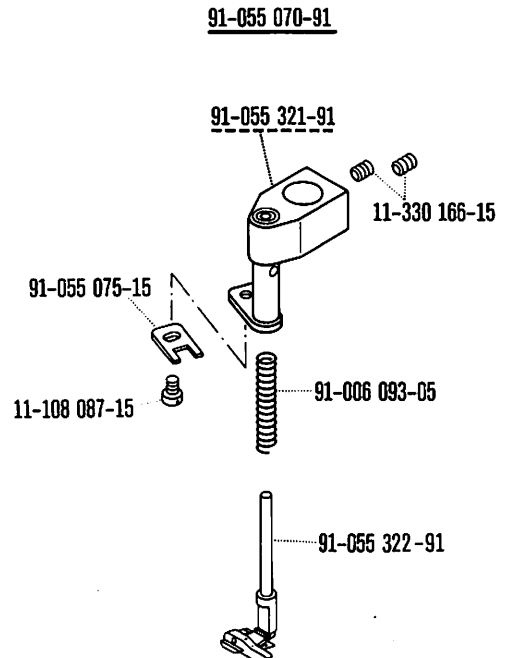
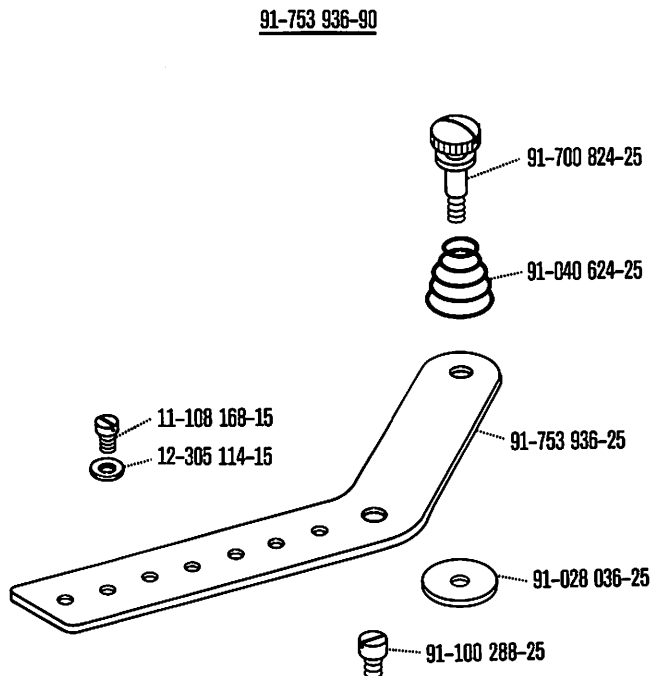

-814/01-19/05 (-800/51; /71)

-814/01-19/05-920/11

-814/01-82/12

-814/01-944/01

91-050 112-91

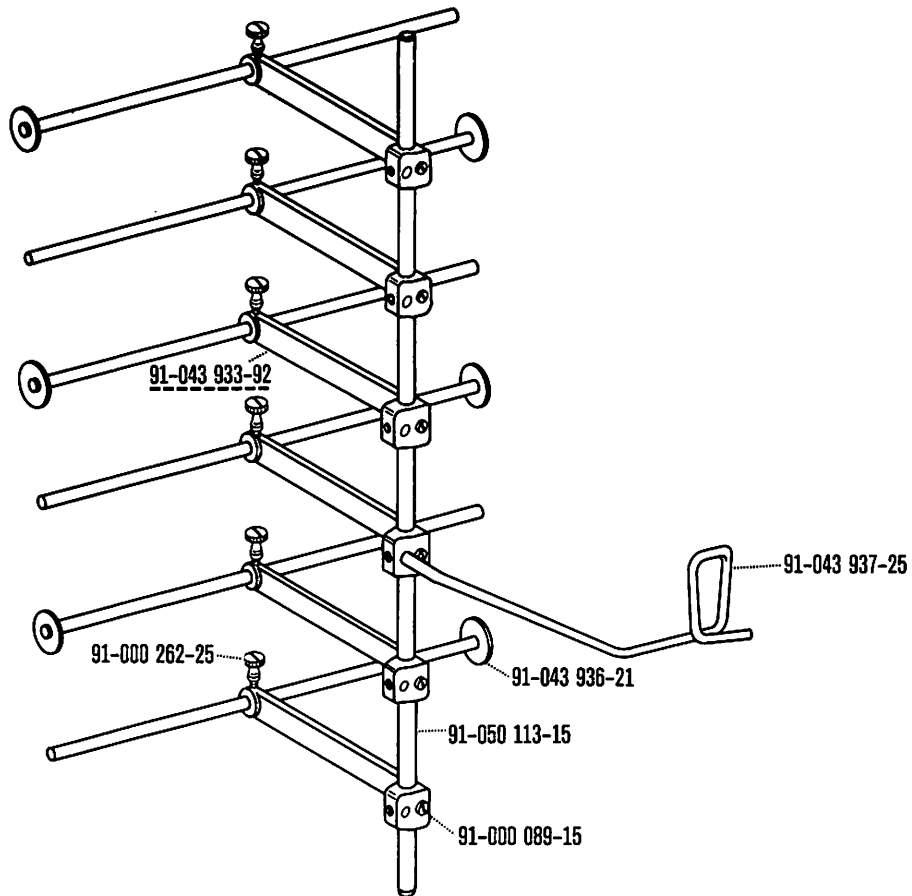

-814/01-61/03

91-050 966-91

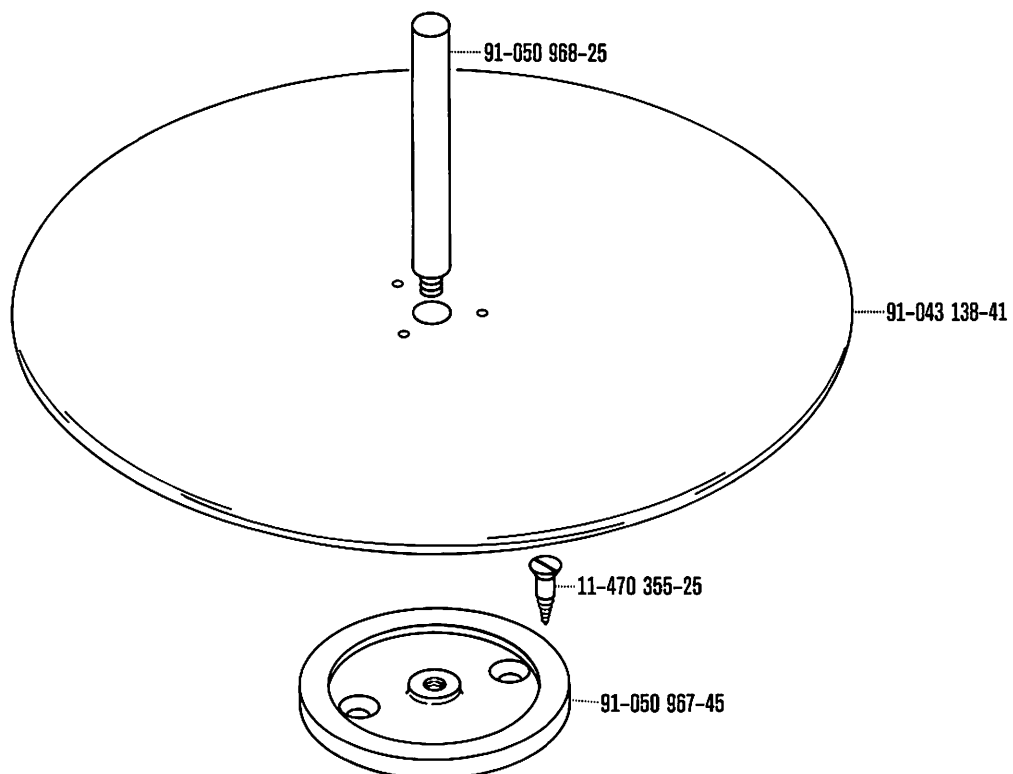

-814/01-17/31
-814/01-39/31

Unterklassen-Übersicht/Table of subclasses/Table des sous-classes/Tabla de subclasses

91-056 532-91

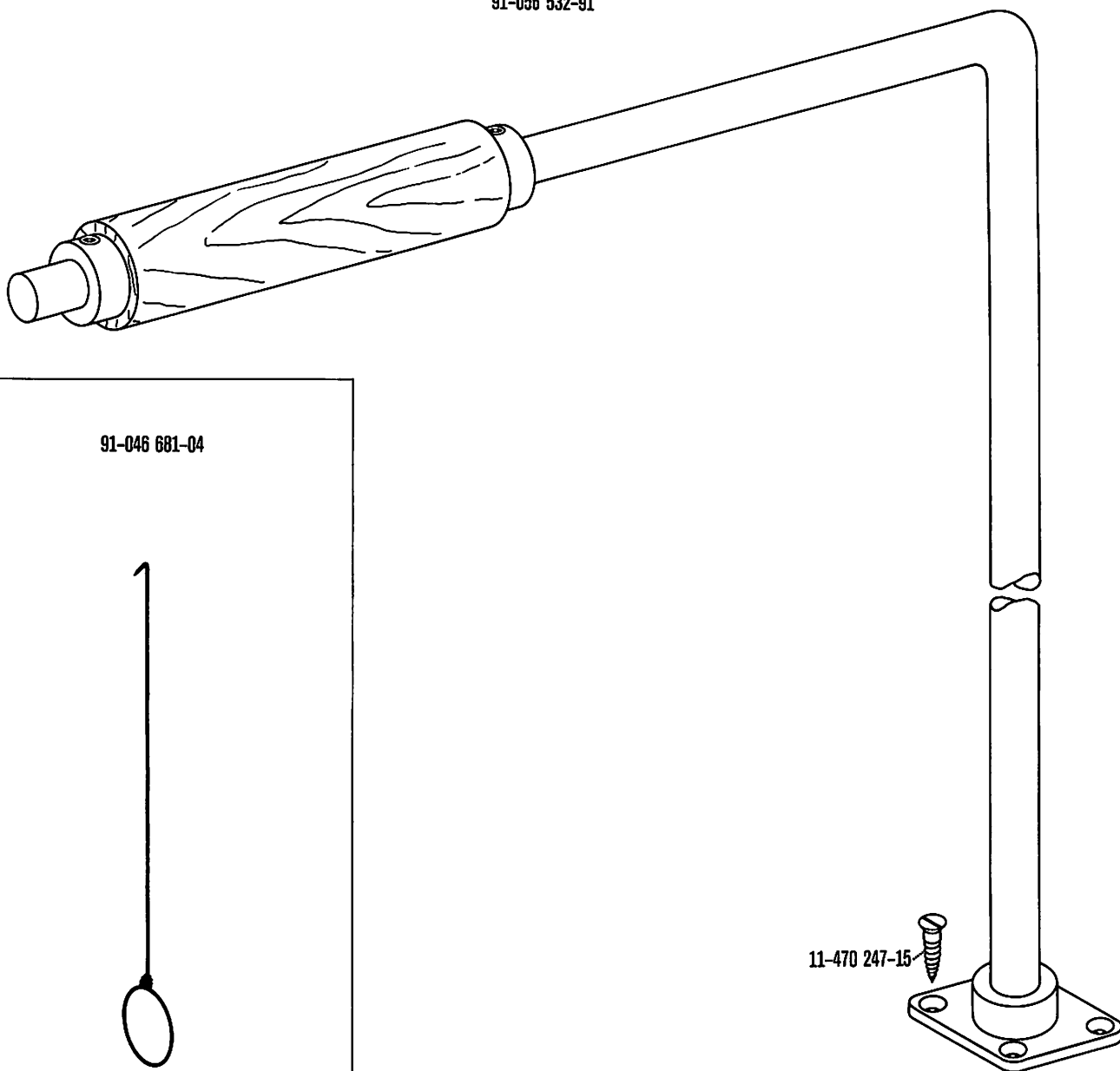

91-046 681-04



-814/01-193/01

-814/06-61/05

91-055 771-01



-818/55-32/01
-818/55-65/01 (-980/11)

91-169 493-91

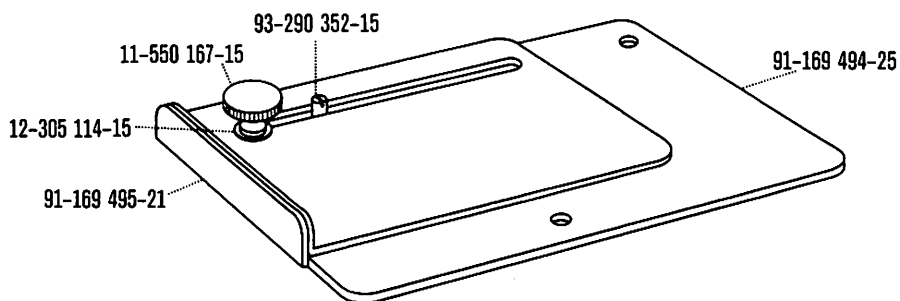

-814/01-61/03

Unterklassen-Übersicht/Table of subclasses/Table des sous-classes/Tabla de subclasses

91-170 420-91

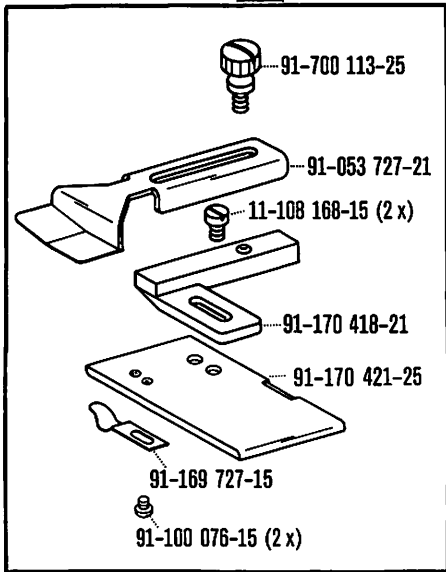

91-056 209-93 [5]

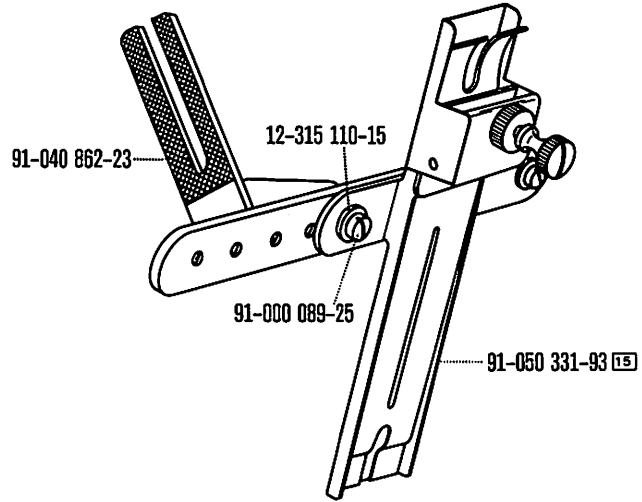

HO-814/01-749/01-6/01

-814/06-61/05

91-168 461-91

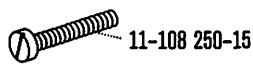
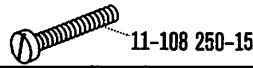
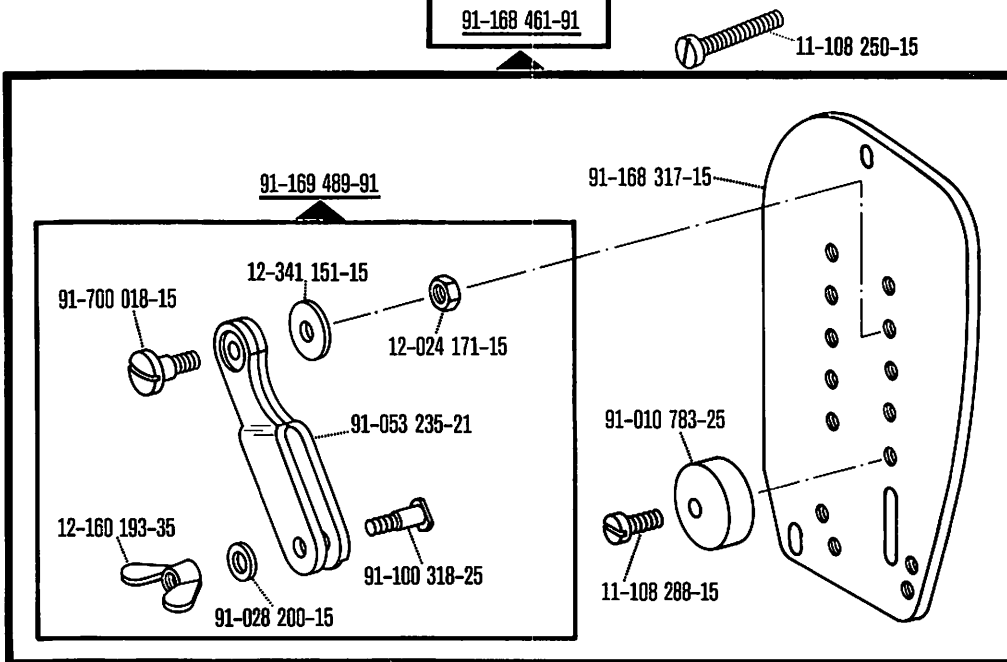



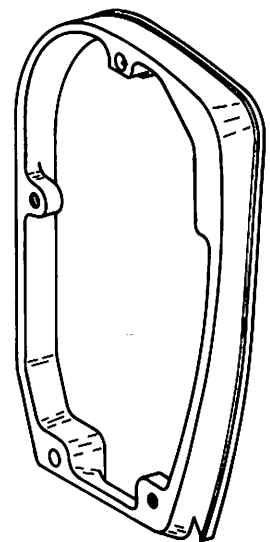







91-172 583-45



-814/01-61/03
 -814/01-309/02-905/..
 -814/06-61/05

Unterklassen-Übersicht/ Table of subclasses/ Table des sous-classes/ Tabla de subclasses

<p align="center">91-169 711-05</p>  <p>H-814/01-6/01 (-900/..) -911/.. H-814/01-6/02 (-900/51; /71) -911/03; /05 H-814/01-6/10 (-900/51; /71) -911/03; /05 H-814/01-6/12-900/51; /71-911/03; /05 -814/06-61/05 -814/06-94/01</p>	<p align="center">91-169 990-05</p>  <p align="center">-814/01-944/01</p>	<p align="center">91-170 378-05</p>  <p align="center">HO-814/02-45/02 (-900/71)</p>
<p align="center">91-170 966-05</p>  <p>-814/01-6/01 (-900/51; /71) -814/01-6/02 (-900/..) -814/01-6/10 (-900/51; /71) -814/01-17/31 -814/01-19/01 (-900/51; /71) -814/01-19/05 (-900/51; /71) -814/01-19/05-920/11 -814/01-39/31 -814/01-139/01 R-814/01-6/02 (-960/81) -814/01-703/01-733/11; /12-39/21 (-960/81) -814/01-731/11; /12-6/01 (-900/51; /71) -814/01-748/56-6/01 (-900/51; /71)</p>	<p align="center">91-172 221-01</p>  <p align="center">HO-814/01-749/01-6/01</p>	<p align="center">91-169 491-05</p>  <p align="center">-814/01-61/03</p>
<p align="center">91-169 863-05</p>  <p align="center">-814/01-6/01</p>	<p align="center">91-169 864-05</p>  <p align="center">-814/01-6/01 -814/01-69/01</p>	<p align="center">91-169 865-05</p>  <p align="center">-814/01-6/01 -814/01-69/01 -814/01-733/11; /12-17/31 -814/01-733/11; /12-39/31</p>
<p align="center">91-169 866-05</p>  <p align="center">-814/01-6/01 (-960/81) -814/01-57/01 -814/01-58/11 -814/01-69/01 -814/01-748/56-6/01 -818/55-6/01 -818/55-32/01 -818/55-65/01 (-960/11)</p>		<p align="center">91-169 867-05</p>  <p align="center">-814/01-6/01 (-960/81) -814/01-57/01 -814/01-58/11 -814/01-69/01 -814/01-748/56-6/01 -818/55-6/01 -818/55-32/01 -818/55-65/01 (-960/11) H-814/01-704/02-748/56-6/01-960/14</p>

Unterklassen-Übersicht/ Table of subclasses/ Table des sous-classes/ Tabla de subclasses

91-169 868-05



91-169 869-05



91-169 870-05



-814/01-6/01 (-960/81)
-814/01-57/01
-814/01-58/11
-814/01-89/01

-814/01-748/56-6/01
-818/55-6/01
-818/55-32/01
-818/55-65/01 (-960/11)
H-814/01-704/02-748/56-6/01-960/14

-814/01-6/01
-814/01-61/03
-814/01-82/12
-814/01-748/56-6/01

-814/01-6/01
-814/01-61/03
-814/01-82/12
-814/01-309/02-905/..
-814/01-748/56-6/01

91-170 368-05



91-172 573-05



91-176 980-05

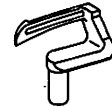

-814/01-6/10

-814/01-6/10

-818/56-65/01 (-960/11)
H-814/01-704/02-748/56-6/01-960/14

91-176 981-05



91-169 492-05



91-169 872-05

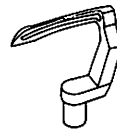

91-169 873-05

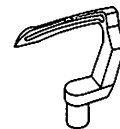

-818/56-65/01 (-960/11)
H-814/01-704/02-748/56
-6/01-960/14

-814/01-61/03

-814/01-6/10

-814/01-6/01

91-169 874-05



91-169 875-05



91-169 876-05

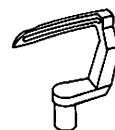





-814/01-6/01
-814/01-69/01

-814/01-6/01
-814/01-69/01

-814/01-6/01 (-960/81)
-814/01-57/01
-814/01-58/11
-814/01-89/01
-814/01-733/11; /12-17/31

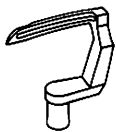
-814/01-733/11; /12-39/31
-814/01-748/56-6/01
-818/55-6/01
-818/55-32/01
-818/55-65/01 (-960/11)

Unterklassen-Übersicht/ Table of subclasses/ Table des sous-classes/ Tabla de subclases

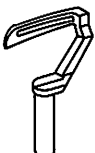
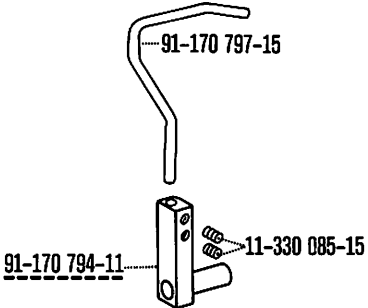
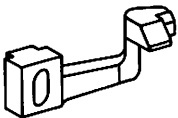
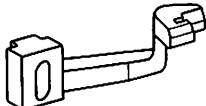
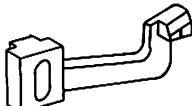
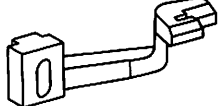
<p align="center">91-169 877-05</p>  <p>-814/01-6/01 (-960/81) -814/01-57/01 -814/01-58/11 -814/01-69/01 -814/01-748/56-6/01</p> <p>-818/55-6/01 -818/55-32/01 -818/55-65/01 (-960/11) H-814/01-704/02-748/56-6/01-960/14</p>	<p align="center">91-169 878-05</p>  <p>-814/01-6/01 (-960/81) -814/01-57/01 -814/01-58/11 -814/01-69/01 -814/01-748/56-6/01</p> <p>-818/55-6/01 -818/55-32/01 -818/55-65/01 (-960/11) H-814/01-704/02-748/56-6/01-960/14</p>	
<p align="center">91-169 879-05</p>  <p>-814/01-6/01 -814/01-61/03 -814/01-82/12 -814/01-748/56-6/01</p>	<p align="center">91-169 880-05</p>  <p>-814/01-6/01 -814/01-61/03 -814/01-82/12 -814/01-309/02-905/.. -814/01-748/56-6/01</p>	<p align="center">91-176 982-05</p>  <p>-818/56-65/01 (-960/11) H-814/01-704/02-748/56-6/01-960/14</p>
<p align="center"><u>91-170 793-11</u></p>  <p>R-814/01-6/02 (-960/81) H-814/01-6/01 (-900/..)-911/.. H-814/01-6/02 (-900/51; /71) -911/03; /05 H-814/01-6/10-911/03; /05 H-814/01-6/10-900/51; /71-911/03; /05 H-814/01-6/12-900/51; /71-911/03; /05 -814/06-61/05 -814/06-94/01</p>		<p align="center">91-172 124-05</p>  <p>-818/55-6/01 -818/55-32/01 -818/55-65/01-960/11</p>
<p align="center">91-172 198-05</p>  <p>-814/01-6/01 (-960/81) -814/01-57/01 -814/01-58/11 -814/01-69/01</p> <p>-814/01-733/11; /12-17/31 -814/01-733/11; /12-39/31 -814/01-748/56-6/01 H-814/01-704/02-748/56-6/01-960/14</p>	<p align="center">91-172 200-05</p>  <p>HD-814/02-45/02 (-900/71) -814/06-61/05 -814/06-94/01</p>	<p align="center">91-172 201-05</p>  <p>-814/01-6/01 -814/01-61/03 -814/01-82/12 -814/01-309/02-905/.. -814/01-748/56-6/01</p>

Unterklassen-Übersicht/Table of subclasses/Table des sous-classes/Tabla de subclasses

91-172 202-05

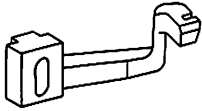

-814/01-6/10

91-172 253-05

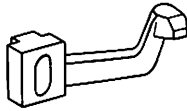

- 814/01-6/01 (-900/51; /71)
- 814/01-6/02 (-900/..)
- 814/01-6/10 (-900/51; /71)
- 814/01-17/31
- 814/01-19/01 (-900/51; /71)
- 814/01-19/05 (-900/51; /71)
- 814/01-19/05-920/11
- 814/01-39/31
- 814/01-193/01
- 814/01-944/01
- H0-814/01-749/01-6/01
- 814/01-703/01-733/11; /12-39/21 (-960/81)
- 814/01-731/11; /12-6/01 (-900/51; /71)
- 814/01-748/56-6/01 (-900/51; /71)

91-172 575-05

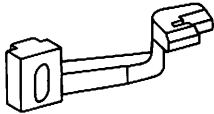

- 814/01-6/01 (-960/81)
- 814/01-57/01
- 814/01-58/11
- 814/01-61/03
- 814/01-69/01
- 814/01-82/12
- 814/01-748/56-6/01

91-176 985-05

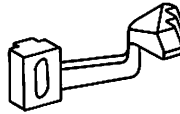

- H-814/01-704/02
- 748/56-6/01-960/14

91-178 022-05

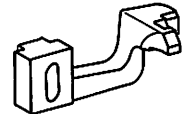

-818/56-65/01 (-960/11)

91-158 847-91

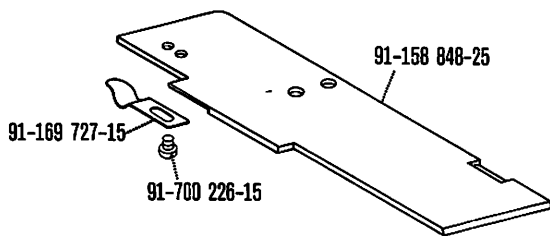

-818/55-65/01-960/11

91-169 821-91

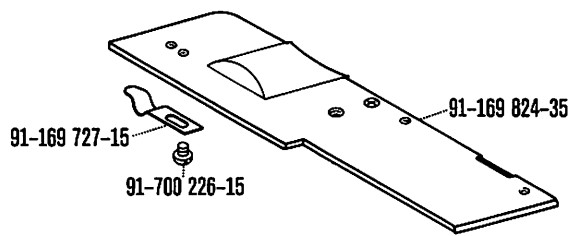

-814/06-61/05
-814/06-94/01

91-169 922-91

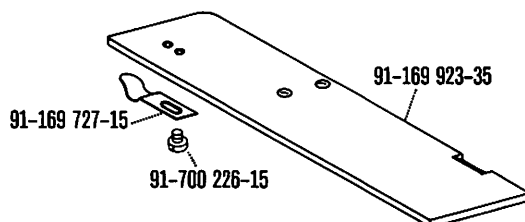

-814/01-6/01
-814/01-61/03
-814/01-82/12
-814/01-309/02-905/..
-814/01-748/56-6/01

Unterklassen-Übersicht/ Table of subclasses/ Table des sous-classes/ Tabla de subclasses

91-170 270-93 9/2

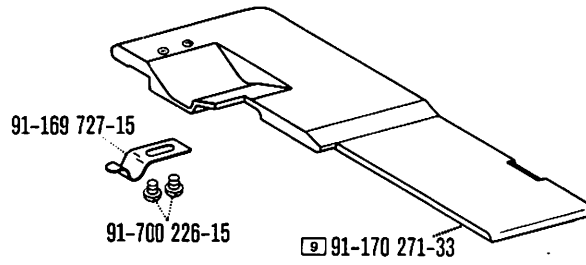

-814/01-731/11; /12-8/01

91-170 365-91

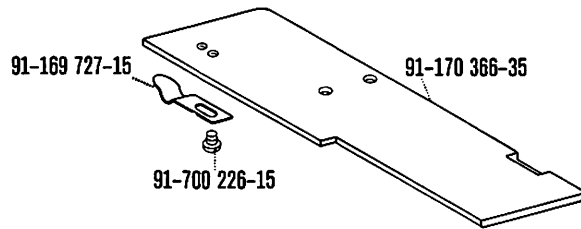

- | | |
|---------------------------|------------------------------------|
| -814/01-6/01 | |
| -814/01-6/02 | |
| -814/01-6/10 | |
| -814/01-193/01 | |
| -814/01-944/01 | |
| R-814/01-6/02 (-960/81) | HO-814/02-45/02 |
| H-814/01-6/01-911/.. | -818/55-6/01 |
| H-814/01-6/02-911/03; /05 | -818/55-32/01 |
| H-814/01-6/10-911/03; /05 | -818/55-65/01 |
| -814/01-748/56-6/01 | H-814/01-704/02-748/56-6/01-960/14 |
| | -814/01-6/01 (-860/11) |
| | -814/01-6/10 |
| | -814/01-69/01 |
| | -814/01-748/56-6/01 |

91-170 410-93 9/2

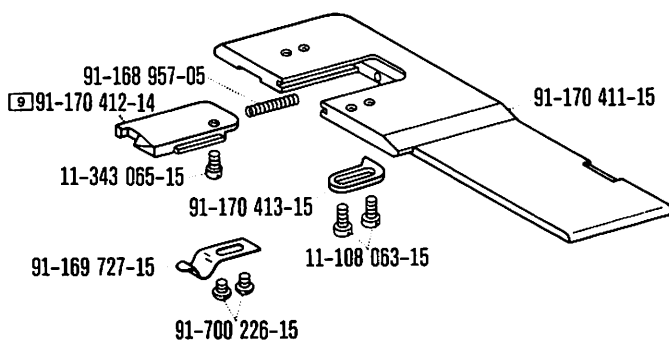

-814/01-731/11; /12

91-170 438-91

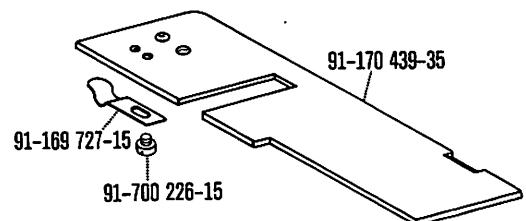

-814/01-17/31
-814/01-39/31

91-172 069-91

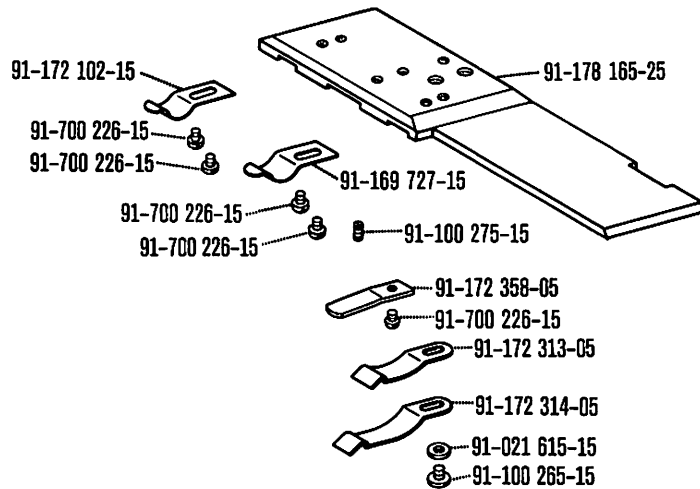

-814/01-6/01-900/51; /71
 -814/01-6/02-900/..
 -814/01-6/10-900/51; /71
 H-814/01-6/01-900/..-911/..
 -814/01-748/56-6/01-900/51; /71
 HO-814/02-45/02-900/71

91-172 160-91

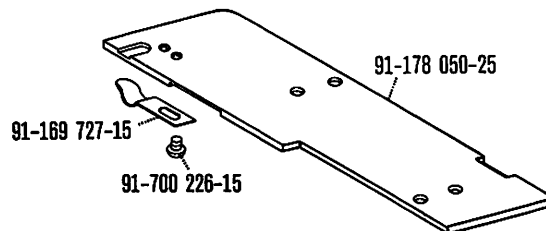

-814/01-6/01 (-860/81)
 -814/01-57/01
 -814/01-69/01
 -814/01-748/56-6/01
 -818/55-6/01
 -818/55-32/01
 -818/55-65/01

91-172 218-91

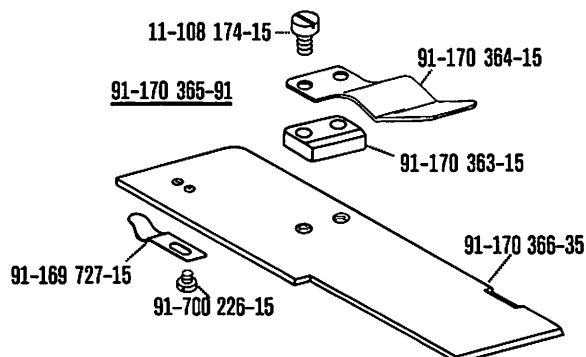

-814/01-19/01
 -814/01-19/05 (-920/11)

91-172 599-91

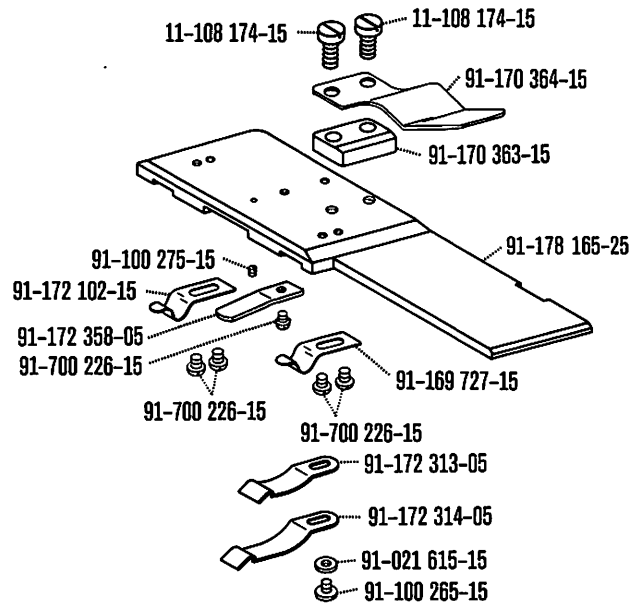

-814/01-19/01-900/51; /71
-814/01-19/05-900/51; /71

91-172 765-91

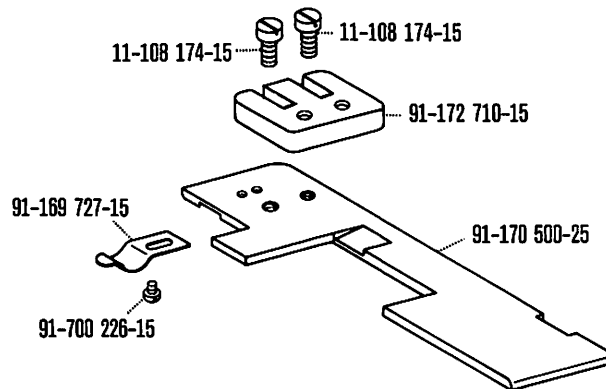

-814/01-733/11; /12-17/31
-814/01-733/11; /12-39/31

91-176 536-91

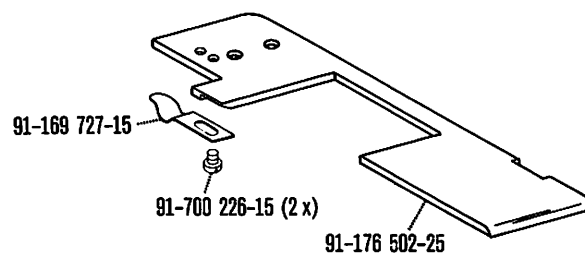

-814/01-703/01-733/11; /12-39/21 (-880/81)

Unterklassen-Übersicht/Table of subclasses/Table des sous-classes/Tabla de subclasses

91-178 046-91

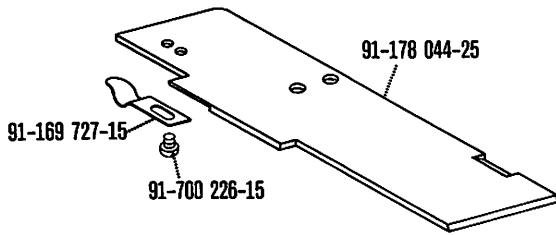

-818/56-65/01 (-960/11)

91-178 051-91

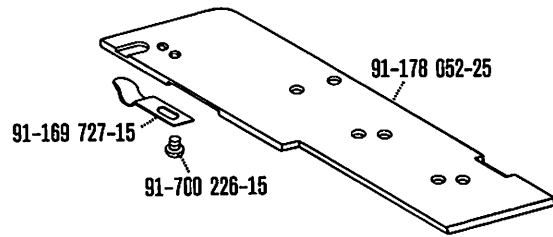

-814/01-58/11

91-178 096-93

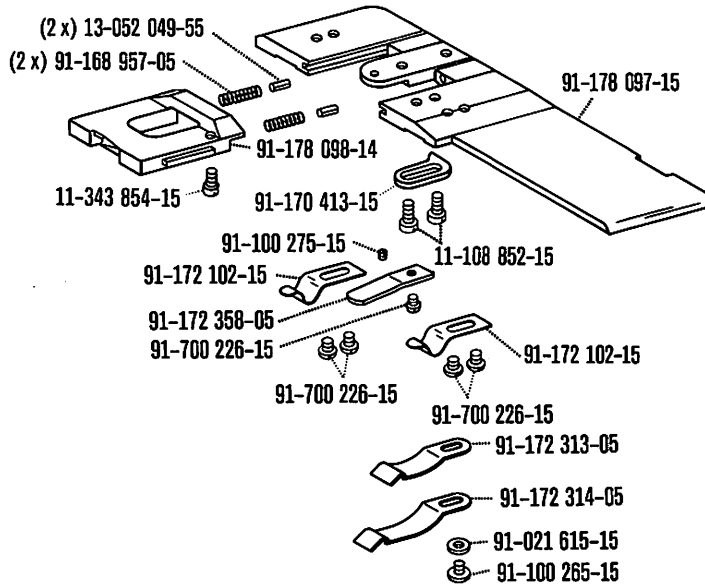

-814/01-731/11; /12-6/01-900/51; /71

91-178 185-91

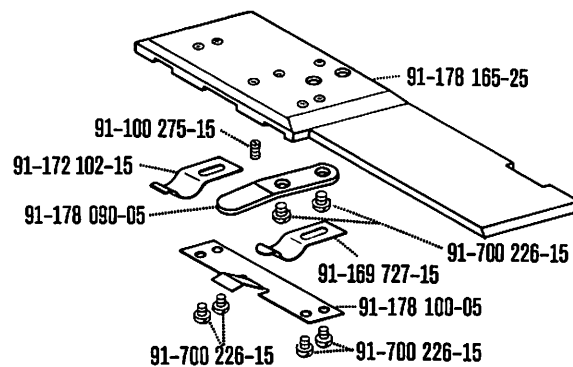

H-814/01-6/02-900/51; /71-911/03; /05
 H-814/01-6/10-900/51; /71-911/03; /05
 H-814/01-6/12-900/51; /71-911/03; /05

Unterklassen-Übersicht/ Table of subclasses/ Table des sous-classes/ Tabla de subclasses

91-169 395-04



-814/01-731/11; /12-6/01 (-900/51; /71)

91-170 416-05



-814/01-733/11; /12-17/31

-814/01-733/11; /12-39/31

91-170 440-05

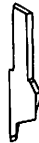

-814/01-703/01-733/11; /12-39/21 (-960/81)

-814/01-733/11; /12-17/31

-814/01-733/11; /12-39/31

91-170 560-04



-814/01-731/11; /12-6/01 (-960/51; /71)

91-171 687-05



HO-814/01-749/01-6/01

91-171 688-05

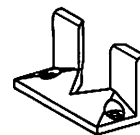

HO-814/01-749/01-6/01

91-176 537-05



-814/01-703/01-733/11; /12-39/21 (-960/81)

Pfaff, D 6750 Kaiserslautern, Postfach 3020/3040, Telex: 045 753, Telefax (0631) 1 7202