AT, TK DEVICE

First edition, issued on June, 1980.

初 版 (1980年 6月 発行)

Second edition, issued on June, 1984.

第 2 版 (1984年 6月 発行)

FOR MACHINE MODELS:

E32, E52.

ETS32, ETS52.

L32, L52, L22.

L132, L152.

R53.

W61, W41.

WS62, WS42.



PEGASUS®

第二版発行に際して

このたび、AT・TK装置のパーツカタログを全面改訂し、第二版として発行致しました。

主な改訂内容は下記の通りです。

- MP(透過式)センサ新規使用によるE32・52、ETS32・52用ATコントローラー及び専用部品の設定。
- ETS32・52用テープカッター、ソレノイド、エアシリンダーの設定。
- ブロワ装置の取付方法の変更。
- ゲージパーツ表の追加。

1984年6月

Preface to the second edition

Since various new components/modifications are now available, this edition has been issued.

The key notes on this booklet are:

- The new AT controllers fitted with the MP sensor for E32, E52, ETS32 and ETS52 machines.
- Tape cutters, solenoids and air cylinders for ETS32 and ETS52 machines.
- Change of the installation manner for the blower device.
- Several new gauge parts lists.

June, 1984

パーツカタログの見方

- このパーツカタログは、1984年4月製造中のAT・TK装置を次の要領で編集しています。
- 2～11頁にはAT・TK装置形式の一覧表を記載し、各形式ごとの適用ミシン及びその構成部品が一覧できます。
- 22～63頁には部品を機構別に収録し、左頁が部品の分解図、右頁がパーツリストになっています。
また、部品分解図に付されている番号は、パーツリストのREF. NO.(参照番号)を示しています。
- ゲージパーツは、装置付ミシンの機種別に64～77頁に一括して記載しています。
- 78～82頁には部品番号インデックスを記載し、部品番号だけで、その図解、名称などが容易に引き出せます。
- 部品をご注文いただくときは、必ず部品番号だけを明示してください。
なお、このパーツカタログの記載事項は改良により、予告なく変更されることがありますので、あらかじめご了承ください。

INTRODUCTION

- This parts catalog covers the AT・TK devices manufactured from April, 1984.
- The functions and specifications of each device are outlined briefly by chart on pages 12-21.
- On pages 22-63, each mechanism is arranged on facing pages, the first page containing the illustrations and the second page containing the data of the individual parts.
The number given to each illustration is the REF. NO. on the parts list.
- Gauge parts are used in some machine types and sewing gauges only. They are listed on pages 64-77 to show the parts data at a glance.
- A part number index is attached to the back of this catalog for convenience.
- When placing orders for parts from this catalog, use ONLY THE PART NUMBER.
- This parts catalog is applicable to your machine and is subject to change without notification.

目次

頁

装置のまとめ	2～11
テープカッター(E32、E52、ETS32、ETS52用)	22～23
" (Lシリーズ用)	24～25
" (R53用)	26～27
" (1)(W、WSシリーズ用)	28～29
" (2)(W、WSシリーズ用)	30～31
ノレノイド/エアシリンダー	32～33
TKコントローラー	34～35
スイッチ(電気式TK装置用)	36～37
制御ユニット(空気圧制御式TK装置用)	38～39
ATコントローラー(CPセンサ)(1)、(2)	40～43
" (MPセンサ)	44～45
センサセット(1)	46～47
" (2)	48～49
ブロワ装置	50～51
ダストドラム(1)、(2)	52～55
ブロワ用リントコレクター	56～57
ベンチュリー装置	58～59
TK装置専用のミシン部品	60～61
AT装置専用のミシン部品	62～63
E32AT/E52ATゲージパーツ	64～65
L132AT/L32ATゲージパーツ	66
L152AT/L52ATゲージパーツ	67
R53TKゲージパーツ	68
E52TKゲージパーツ	69～70
L52TKゲージパーツ	71～73
ETS32AT/ETS52ATゲージパーツ	74～77
部品番号インデックス	78～82

TABLE OF CONTENTS

page

SUMMARY OF EACH DEVICE	12～21
Tape Cutter (for E32, E52, ETS32, ETS52)	22～23
" " (for L series)	24～25
" " (for R53)	26～27
" " (1) (for W, WS series)	28～29
" " (2) (for W, WS series)	30～31
Solenoid/Air Cylinder	32～33
TK Controller	34～35
Switches (for Solenoid operated TK Device)	36～37
Control Unit (for pneumatically operated TK Device)	38～39
AT Controller (CP Sensor) (1), (2)	40～43
" " (MP Sensor)	44～45
Sensor set (1)	46～47
Sensor set (2)	48～49
Blower Device	50～51
Dust Drum (1), (2)	52～55
Waste Receptacle (for Blower Device)	56～57
Venturi Device	58～59
Specific machine parts (for TK Device only)	60～61
Specific machine parts (for AT Device only)	62～63
E32AT/E52AT gauge parts	64～65
L132AT/L32AT gauge parts	66
L152AT/L52AT gauge parts	67
R53TK gauge parts	68
E52TK gauge parts	69～70
L52TK gauge parts	71～73
ETS32AT/ETS52AT gauge parts	74～77
Part number index	78～82

装置・形式及び部品の選びかた(表1~9参照)

ミシンの機種・形式は知っているが、どの装置形式が適しているかを知りたい。	➡	適用マシン欄よりミシンの機種・形式を求め、ミシンの用途に応じた装置・形式を選んでください。表1~9参照。
装置形式の主な構成部品を知りたい。	➡	装置形式欄より正しい装置形式を求め、適用マシン欄の専用部品と装置形式欄の部品を選んでください。表1~9参照。
装置形式にどの付帯装置が適しているかを知りたい。	➡	表18を参照して、電源、電圧及び周波数に合った付帯装置を選んでください。
装置形式及び主な構成部品は知っているが、個々の素子部品を知りたい。	➡	表1~9を参照して、装置形式の構成部品名称を参考に、目次(1頁)→本文の順に、素子部品を求め、主な構成部品の部品番号を参考に、インデックス→本文の順に素子部品を求めてください。

表1



適用マシン		AT装置形式	
機種・形式・ゲージ	専用部品	連続式	自動切替式
E 32-410-2×4 420-3×4	クロスプレート 301243 ファン(組) 301274 センサ・セット ※301599	AT001	AT051
E 32-411-3×4, 430-3×4,-5×5 450-5×6 E 52-132-W2×3,140-W2×4 250C、252	クロスプレート 301241 ファン(組) 301274 センサ・セット ※301599	AT002	AT052
E 52-121/504-243 130 133-N2×3 250	クロスプレート 301181 ファン(組) 301274 センサ・セット ※301599	AT004	AT054
 AT装置構成部品 ➡		テープカッター 301161 ソレノイド(組) 811032 ATコントローラー 100V 760081 200V 760082 220V/240V 760083 380V/415V 760084	テープカッター 301161 ソレノイド(組) 811032 吸込切替弁(組) 303713 グストドラム 303747 ATコントローラー 100V 760081 200V 760082 220V/240V 760083 380V/415V 760084
<ul style="list-style-type: none"> ● ミシンのゲージパーツは、ゲージパーツ表(64頁)を参照してください。 ● ATコントローラーは、電源の電圧及び相数に合ったものをご使用ください。 			

表2

適用マシン		AT装置形式	
機種・形式・ゲージ	専用部品	連続式	自動切替式
L 132-36-3×4 38-3×4	クロスプレート 303764 アーム(左) 303424-HD ファン(組) 303729 足掲レバー 303854 針糸カバー 303812 センサ・セット ※303783	AT005	AT055
L 132-70-5×5 86-5×6	クロスプレート 303777 アーム(左) 303424-HD ファン(組) 303729 足掲レバー 303854 針糸カバー 303812 センサ・セット ※303783	AT006	AT056
L 32-36-3×4 38-3×4 70-5×5 86-5×6	クロスプレート 303758 アーム(左) 303424-FD フーリー蓋(組) 303973 足掲レバー 303854 針糸カバー 303812 シリコンハイフ(上) 303714 " 当金 303708 当金止ネジ 5077 センサ・セット ※303823	AT007	AT057
 AT装置構成部品 ➡		テープカッター 303772 ソレノイド(組) 811032 ATコントローラー 100V 760081 200V 760082 220V/240V 760083 380V/415V 760084	テープカッター 303772 ソレノイド(組) 811032 吸込切替弁(組) 303713 グストドラム 303747 ATコントローラー 100V 760081 200V 760082 220V/240V 760083 380V/415V 760084
<ul style="list-style-type: none"> ● ミシンのゲージパーツは、ゲージパーツ表(66頁)を参照してください。 ● ATコントローラーは、電源の電圧及び相数に合ったものをご使用ください。 			

※(CPセンサ)





適用 ミ シ ン		A T 装 置 形 式	
機種・形式・ゲージ	専用部品	連続式	自動切替式
L152-11,12,23-2×3 2×4 26,27,28×4	クロスプレート 303808 アーム(左) 303424-HD ファン(組) 303729 足掲レバー 303854 針糸カバー 303812 センサーセット※303782	AT008	AT058
L152-13-2×3 2×4 17×4	クロスプレート 303810 アーム(左) 303424-HD ファン(組) 303729 足掲レバー 303854 針糸カバー 303812 センサーセット※303782	AT009	AT059
L52-11,12,23-2×3 2×4 26,27,28×4	クロスプレート 303808 アーム(左) 303424-FD ブリーチ蓋(組) 303973 足掲レバー 303854 針糸カバー 303812 シリコンパイプ(上) 303714 " 当金 303708 当金止ネジ 5077 センサーセット※303822	AT010	AT060
L52-13-2×3 2×4 17×4	クロスプレート 303810 アーム(左) 303424-FD ブリーチ蓋(組) 303973 足掲レバー 303854 針糸カバー 303812 シリコンパイプ(上) 303714 " 当金 303708 当金止ネジ 5077 センサーセット※303822	AT011	AT061
 A T 装置構成部品 		テープカッター 303774 ソレノイド(組) 811032 A T コントローラー 100V 760081 200V 760082 220V/240V 760083 380V/415V 760084	テープカッター 303774 ソレノイド(組) 811032 吸込切替弁(組) 303713 ダストドラム 303747 A T コントローラー 100V 760081 200V 760082 220V/240V 760083 380V/415V 760084
<ul style="list-style-type: none"> ● ミシンのゲージパーツは、ゲージパーツ表(67頁)を参照してください。 ● A T コントローラーは、電源の電圧及び相数に合ったものをご使用ください。 			

表4

適用 ミ シ ン		A T 装 置 形 式	
機種・形式	専用部品	カラ環、切屑の吸込なし	
W61-01,02,06,07 W41-01,02,04,06,07	後カバー 306024 平カバー 306969 ハンドホイール 306260	AT041	
WS62-01, 02 WS42-01, 02	クロスプレート 306617 平カバー 306588 ハンドホイール 307072-FD 面板 306618 切屑カバー 306589 止ネジ 1227	AT042	
 A T 装置構成部品 		テープカッター 306263 センサ・セット ※306612	
<ul style="list-style-type: none"> ● A T コントローラーは、電源の電圧及び相数に合ったものをご使用ください。 		A T コントローラー 100V 760081 200V 760082 220V/240V 760083 380V/415V 760084	

※(CPセンサー)

表5









適用 ミ シ ン		A T 装 置 形 式	
機種・形式・ゲージ	専用部品	連 続 式	自 動 切 替 式
ETS32-430BA2, 432BA2, 452BA2, 453BA2 ETS32-420FA2, 432FA2, 432FC2/P1, 432FC2/P2, 542FD2 ETS52-141BA2-W, 142BA2/514-W, 350BC-W, 351BC-W ETS52-142FA2/514-W, 142FB2/514-W, 351FC2/P1-W, 351FC2/P2-W	ファン(組) 301274 センサ・セット 301916 (MPセンサ)	ATO12	AT062
 A T 装置構成部品 		テープカッター 301751 ソレノイド(組) 811025 A T コントローラー 200V 760132	テープカッター 301751 ソレノイド(組) 811025 吸込切替弁(組) 303713 グストドラム 303747 A T コントローラー 200V 760132
<ul style="list-style-type: none"> ● ミシンのゲージパーツは、ゲージパーツ表(74~77頁)を参照してください。 ● クロスプレートは、構成部品に含まれません。(60~61頁参照) 			



表6

適用 ミ シ ン		A T 装 置 形 式	
機種・形式・ゲージ	専用部品	連 続 式	自 動 切 替 式
E32-410-2×4, 411-3×4, 420-3×4, 430-3×4, -5×5, 450-5×6 E52-130/504-263-N4, 5, 6, 132-W2×3, 133-N2×3, 140-W2×4, 250-N2×3, 250C-W2×3	ファン(組) 301274 センサ・セット 301916 (MPセンサ)	ATO21	AT071
 A T 装置構成部品 		テープカッター 301161 ソレノイド(組) 811032 A T コントローラー 200V 760132	テープカッター 301161 ソレノイド(組) 811032 吸込切替弁(組) 303713 グストドラム 303747 A T コントローラー 200V 760132
<ul style="list-style-type: none"> ● ミシンのゲージパーツは、ゲージパーツ表(65頁)を参照してください。 ● クロスプレートは、構成部品に含まれません。(62~63頁参照) 			

適用 ミ シ ン		A T 装 置 形 式
機種・形式・ゲージ	専 用 部 品	カラ環、切屑の吸込なし
E 32-410-2×4 420-3×4	クロスプレート 301157 ファン(組) 301274 センサ・セット ※301599	AT081
E 32-411-3×4, 430-3×4,-5×5 450-5×6 E 52-132-W2×3,140-W2×4 250C, 252	クロスプレート 301143 ファン(組) 301274 センサ・セット ※301599	AT082
E 52-130 133-N2×3 250	クロスプレート 301145 ファン(組) 301274 センサ・セット ※301599	AT084
 AT装置構成部品 		テープカッター 301168 ソレノイド(組) 811032 ATコントローラー 100V 760081 200V 760082 220V/240V 760083 380V/415V 760084
<ul style="list-style-type: none"> ● ミシンのゲージパーツは、ゲージパーツ表(64頁)を参照してください。 ● ATコントローラーは、電源の電圧及び相数に合ったものをご使用ください。 		

適用 ミ シ ン		A T 装 置 形 式
機種・形式・ゲージ	専 用 部 品	カラ環、切屑の吸込なし
L 132-36-3×4 38-3×4	クロスプレート 303802 アーム(左) 303424-HD ファン(組) 303729 足揚レバー 303854 針糸カバー 303812 センサ・セット ※303783	AT085
L 132-70-5×5 86-5×6	クロスプレート 303800 アーム(左) 303424-HD ファン(組) 303729 足揚レバー 303854 針糸カバー 303812 センサ・セット ※303783	AT086
L 32-36-3×4 38-3×4 70-5×5 86-5×6	クロスプレート 303432 アーム(左) 303424-FD ブリーチ蓋(組) 303973 足揚レバー 303854 針糸カバー 303812 シリコンパイプ(上) 303714 ・ 当金 303708 当金止ネジ 5077 センサ・セット ※303823	AT087
 AT装置構成部品 		テープカッター 303781 ソレノイド(組) 811032 ATコントローラー 100V 760081 200V 760082 220V/240V 760083 380V/415V 760084
<ul style="list-style-type: none"> ● ミシンのゲージパーツは、ゲージパーツ表(66頁)を参照してください。 ● ATコントローラーは、電源の電圧及び相数に合ったものをご使用ください。 		

*(CPセンサ)

適用ミシン		AT装置形式
機種・形式・ゲージ	専用部品	カラ環、切屑の吸込なし
L152-11,12,23-2×3 2×4 26,27,28×4	クロスプレート 303431 アーム(左) 303424-HD ファン(組) 303729 足揚レバー 303854 針糸カバー 303812 センサ・セット※303782	AT088
L152-13-2×3 2×4 17×4,×5,×6	クロスプレート 303433 アーム(左) 303424-HD ファン(組) 303729 足揚レバー 303854 針糸カバー 303812 センサ・セット※303782	AT089
L52-11,12,23-2×3 2×4 26,27,28×4,×5,×6	クロスプレート 303431 アーム(左) 303424-FD プーリー蓋(組) 303973 足揚レバー 303854 針糸カバー 303812 シリコンパイプ(上) 303714 * 当金 303708 当金止ネジ 5077 センサ・セット※303822	AT090
L52-13-2×3 2×4 17×4,×5,×6	クロスプレート 303433 アーム(左) 303424-FD プーリー蓋(組) 303973 足揚レバー 303854 針糸カバー 303812 シリコンパイプ(上) 303714 * 当金 303708 当金止ネジ 5077 センサ・セット※303822	AT091
 AT装置構成部品 		テープカッター 303780 ソレノイド(組) 811032 ATコントローラー 100V 760081 200V 760082 220V/240V 760083 380V/415V 760084
<ul style="list-style-type: none"> ● ミシンのゲージパーツは、ゲージパーツ表(67頁)を参照してください。 ● ATコントローラーは、電源の電圧及び相数に合ったものをご使用ください。 		

※(CPセンサ)

装置・形式及び部品の選びかた(表10~16参照)

ミシンの機種・形式は知っているが、どの装置形式が適しているかを知りたい。	➡	適用マシン欄よりミシンの機種・形式を求め、ミシンの用途に応じた装置・形式を選んでください。表10~16参照。
装置形式の主な構成部品を知りたい。	➡	装置形式欄より正しい装置形式を求め、適用マシン欄の専用部品と装置形式欄の部品を選んでください。表10~16参照。
装置形式及び主な構成部品は知っているが、個々の素子部品を知りたい。	➡	表10~16を参照して、装置形式の構成部品名称を参考に、目次(1頁)→本文の順に、素子部品を求め、主な構成部品の部品番号を参考に、インデックス→本文の順に素子部品を求めてください。

表10

適用マシン		TK装置形式		
機種・形式	専用部品	電気式 手動スイッチ	電気式 ヒザスイッチ	空気制御式 ヒザ操作
E 32-410, 420	クロスプレート 301157	TK001 ※(TKE-320)	TK031 ※(TKE-320)	TK061 ※(TKE-320)
E 32-411, 430, 440 450, 540, 541 542, 543 E 52-121, 136 130, 131, 132 134, 135, 140 220, 221, 240 241, 242, 243 250C, 261	クロスプレート 301143	TK002 ※(TKE-320)	TK032 ※(TKE-320)	TK062 ※(TKE-320)
E 52-120, 130, 133 210, 210C, 211 250	クロスプレート 301145	TK003 ※(TKE-320)	TK033 ※(TKE-320)	TK063 ※(TKE-320)
↑ TK装置構成部品 ➡		テープカッター 301168 ソレノイド(組) 811032 手動スイッチ(組) 303510 TKコントローラー 100V 760041 200~250V 760040 380V 760044	テープカッター 301168 ソレノイド(組) 811032 ヒザスイッチ(組) 708004 ブラケット(組) 303010 TKコントローラー 100V 760041 200~250V 760040 380V 760044	テープカッター 301168 エアシリンダー(組) 513016 制御ユニット 605003
備 考		●TKコントローラーは電源電圧及び相数に合ったものをご使用ください。		



*印は旧機種名です。

適用 ミ シ ン		T K 装 置 形 式		
機種・形式	専用部品	電 気 式 手動スイッチ	電 気 式 ヒザスイッチ	空 気 制 御 式 ヒザ 操 作
L132-05,06,07,08 36,37,38,39 40,41	クロスプレート 303802	TK004 ※(TKL-320)	TK034 ※(TKL-320)	TK064 ※(TKL-320)
L132-30,31,32,33, 48,49,70,71, 78,79,86,87	クロスプレート 303800	TK005 ※(TKL-320)	TK035 ※(TKL-320)	TK065 ※(TKL-320)
L32全機種 L22-02, 04 L122-02, 04	クロスプレート 303432	TK009 ※(TKL-320)	TK039 ※(TKL-320)	TK069 ※(TKL-320)
↑ TK装置構成部品 →		テープカッター 303781 ソレノイド(組) 811032 手動スイッチ(組) 303510 足揚レバー 303854 TKコントローラー 100V 760041 200~250V 760040 380V 760044	テープカッター 303781 ソレノイド(組) 811032 ヒザスイッチ(組) 708004 ブラケット(組) 303010 足揚レバー 303854 TKコントローラー 100V 760041 200~250V 760040 380V 760044	テープカッター 303781 エアシリンダー(組) 513016 制御ユニット 605003 足揚レバー 303130
備 考		●TKコントローラーは電源電圧及び相数に合ったものをご使用ください。		



*印は旧機種名です。

適用 ミ シ ン		T K 装 置 形 式		
機種・形式	専用部品	電 気 式 手動スイッチ	電 気 式 ヒザスイッチ	空 気 制 御 式 ヒザ 操 作
L152-03,09,11,12 L52 23,24,26,27 28,29,31,34 37,51,52,53 54,55,56,57 59,18s4,18s5	クロスプレート 303431	TK006 ※(TKL-520)	TK036 ※(TKL-520)	TK066 ※(TKL-520)
L152-01,01S,02,05 L52 13,15,17,25	クロスプレート 303433	TK007 ※(TKL-520)	TK037 ※(TKL-520)	TK067 ※(TKL-520)
↑ TK装置構成部品 →		テープカッター 303780 ソレノイド(組) 811032 手動スイッチ(組) 303510 足揚レバー 303854 TKコントローラー 100V 760041 200~250V 760040 380V 760044	テープカッター 303780 ソレノイド(組) 811032 ヒザスイッチ(組) 708004 ブラケット(組) 303010 足揚レバー 303854 TKコントローラー 100V 760041 200~250V 760040 380V 760044	テープカッター 303780 エアシリンダー(組) 513016 制御ユニット 605003 足揚レバー 303130
●ミシンのゲージパーツは、ゲージパーツ表(71~73頁)を参照してください。		●TKコントローラーは電源電圧及び相数に合ったものをご使用ください。		
備 考				

*印は旧機種名です。

適用マシン		TK装置形式		
機種・形式	専用部品	電気式 手動スイッチ	電気式 ヒザスイッチ	空気制御式 ヒザ操作
R53 (-41, 49以外の) 全機種	クロスプレート 300066 アーム(B) 300296-FD 送り台カバー 300297 ベッド 300301	TK008 ※(TKR-530)	TK038 ※(TKR-530)	TK068 ※(TKR-530)
 TK装置構成部品 		テープカッター 300303 ソレノイド(組) 811032 手動スイッチ(組) 303510 TKコントローラー 100V 760041 200~250V 760040 380V 760044	テープカッター 300303 ソレノイド(組) 811032 ヒザスイッチ(組) 708004 ブラケット(組) 303010 TKコントローラー 100V 760041 200~250V 760040 380V 760044	テープカッター 300303 エアシリンター(組) 513016 制御ユニット 605003
備考		●TKコントローラーは電源電圧及び相数に合ったものをご使用ください。		

*印は旧機種名です。

適用マシン		TK装置形式		
機種・形式	専用部品	電気式 ヒザスイッチ	空気制御式 ヒザ操作	足踏式
W61-01, 02, 05 W41-01, 02, 04	後カバー 306024	TK041 ※(TKW-630)	TK070 ※(TKW-623)	
WS 62-01, 02 WS 42-01, 02	平カバー 306588-FD 切屑カバー 306589 止ネジ 1227	TK042 ※(TKW-630)	TK071 ※(TKW-623)	
WS 62-05 WS 42-05	平カバー 306613-FD 切屑カバー 306589 止ネジ 1227	TK043 ※(TKW-630)	TK072 ※(TKW-623)	
W61-01, 02, 05 W41-01, 02, 04	後カバー 306724-FD			TK090 ※(TK4)
WS 62-01, 02 WS 42-01, 02	平カバー 306725-FD			TK091 ※(TK4)
W41-01/UT, 02/UT	後カバー 306726-FD			TK092 ※(TK4)
WS 42-01/UT, 02/UT	平カバー 306727-FD			TK093 ※(TK4)
 TK装置構成部品 		テープカッター 306263 ヒザスイッチ(組) 708004 ブラケット(組) 303010 TKコントローラー 100V 760041 200~250V 760040 380V 760044	テープカッター 306590 制御ユニット 605003	テープカッター 306712 ペダル 478
備考		●TKコントローラーは電源電圧及び相数に合ったものをご使用ください。		

*印は旧機種名です。

表15

適用マシン	TK装置形式		
	電気式 手動スイッチ	電気式 ヒザスイッチ	空気制御式 ヒザ操作
ETS32 ETS52	TKO10	TKO11	TKO12
<p style="text-align: center;">↑</p> <p style="text-align: center;">TK装置構成部品 →</p> <p>●クロスプレートは、構成部品に含まれません。(60・61頁参照)</p>	テープカッター 301749 ソレノイド(組) 811025 手動スイッチ(組) 303510 TKコントローラー 100V 760041 200~250V 760040 380V 760044	テープカッター 301749 ソレノイド(組) 811025 ヒザスイッチ(組) 708004 ブラケット(組) 303010 TKコントローラー 100V 760041 200~250V 760040 380V 760044	テープカッター 301749 エアシリンダー(組) 513044 制御ユニット 605003
備考	●TKコントローラーは電源電圧及び相数に合ったものをご使用ください。		

表16

適用マシン	TK装置形式		
	電気式 手動スイッチ	電気式 ヒザスイッチ	空気制御式 ヒザ操作
L152-18s4,18s5 L52-18s4,18s5	TKO17	TKO18	TKO19
<p style="text-align: center;">↑</p> <p style="text-align: center;">TK装置構成部品 →</p> <p>●マシンのゲージパーツは、ゲージパーツ表(72頁)を参照してください。 ●クロスプレートは、構成部品に含まれません。(60・61頁参照)</p>	テープカッター 304071 ソレノイド(組) 811032 手動スイッチ(組) 303510 足揚レバー 303854 TKコントローラー 100V 760041 200~250V 760040 380V 760044	テープカッター 304071 ソレノイド(組) 811032 ヒザスイッチ(組) 708004 ブラケット(組) 303010 足揚レバー 303854 TKコントローラー 100V 760041 200~250V 760040 380V 760044	テープカッター 304071 エアシリンダー(組) 513016 制御ユニット 605003 足揚レバー 303130
備考	●TKコントローラーは電源電圧及び相数に合ったものをご使用ください。		

装置の表わしかた (例: AT装置)

装置 (AT、TK装置) とその付帯装置は、次のように表わします。

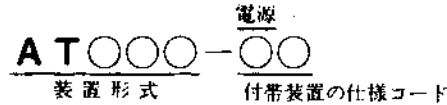

装置形式について

装置形式は、適用ミシンに装置をセットするために必要なパーツと、装置を機能させるために必要なパーツとの組合せによって決められています。これらのパーツは、表1~16で、○○装置構成部品として表わされています。

付帯装置の仕様コードについて

付帯装置の仕様コードは、電源と構成部品との組合せによって決められています。表18参照。

電源について

電源は、電圧と相数との組合せでコード化されています。表17参照。

表示例

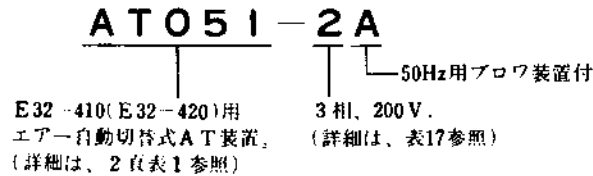

電圧/相数コード表 表17

コード	電圧	相数
0	—	—
1	100V	1
2	200V	3
3	220V	3
4	240V	3
5	380V	3
6	415V	3
7	220V	1
8	240V	1

AT装置とその付帯装置適用表

コントローラーの電圧を指定してください。表18

付帯装置の仕様コード		1A	1B	2A	2B	1C	1D	2C	2D	1E	1F	2E	2F	OG (旧名: VSA-200)
機種別	相数 電圧 周波数	単相 100V 50Hz	単相 100V 60Hz	三相 200V 50Hz	三相 200V 60Hz	単相 100V 50Hz	単相 100V 60Hz	三相 200V 50Hz	三相 200V 60Hz	単相 100V 50Hz	単相 100V 60Hz	三相 200V 50Hz	三相 200V 60Hz	エアーコンプレッサーを使用。
	*プロワ装置	500007	500005	500008	500006	500007	500005	500008	500006	500007	500005	500008	500006	300207 ベンチュリー装置
	リントコレクター(組)	—	—	—	—	300305	300305	300305	300305	—	—	—	—	
ダストドラム	—	—	—	—	—	—	—	—	303747	303747	303747	303747		
適用装置形式		AT051~AT071				AT001~AT021				AT001~AT021				AT001 AT021
備考		カラ環・テープ吸込と メス切屑吸込は、自動切替。 ダストドラムは、標準装備。				カラ環切り。 エアーは、連続吸込。				カラ環及びテープ切り。 エアーは、連続吸込。				カラ環切り。

*50・51頁参照。

HOW TO SELECT CORRECT DEVICE TYPE AND PARTS (Tables 1-9)

You want to select the correct Device Type and you know the machine type that requires the Device.



Choose the machine type in the column "MACHINE TYPE", and select the correct Device Type depending on your requirements.

You want to know the component parts of your Device Type.



Check your Device Type in the column "DEVICE TYPE", and look for the COMPONENT PARTS. Please note that the contents of each component part are clarified in further detail on pages 22-63.

You want to know the correct Auxiliary Device for your Device Type.



Select the correct Auxiliary Devices from Table 18 on page 21.

Tab.1

MACHINE TYPE · GAUGE	SPECIFIC PARTS	AT DEVICE TYPE	
		CONTINUOUS VACUUM TYPE	VACUUM SWITCHING TYPE
E 32-410-2×4 420-3×4	Cloth plate 301243 Fan assembly 301274 Sensor set *301599	AT001	AT051
E 32-411-3×4, 430-3×4, -5×5 450-5×6 E 52-132-W2×3, 140-W2×4 250 C, 252	Cloth plate 301241 Fan assembly 301274 Sensor set *301599	AT002	AT052
E 52-121/504-243 130 133-N2×3 250	Cloth plate 301181 Fan assembly 301274 Sensor set *301599	AT004	AT054
<p>AT DEVICE COMPONENT PARTS →</p> <p>See page 64 for the gauge parts. Use the AT controller suitable to the power source.</p>		Tape cutter 301161 Solenoid assembly 811032 AT controller 100 V 760081 200 V 760082 220 V /240 V 760083 380 V /415 V 760084	Tape cutter 301161 Solenoid assembly 811032 Vacuum switching valve 303713 Dust drum 303747 AT controller 100 V 760081 200 V 760082 220 V /240 V 760083 380 V /415 V 760084

Tab.2

MACHINE TYPE · GAUGE	SPECIFIC PARTS	AT DEVICE TYPE	
		CONTINUOUS VACUUM TYPE	VACUUM SWITCHING TYPE
L 132-36-3×4 38-3×4	Cloth plate 303764 Arm (left) 303424-HD Fan assembly 303729 Foot lift lever 303854 Needle thread cover 303812 Sensor set *303783	AT005	AT055
L 132-70-5×5 86-5×6	Cloth plate 303777 Arm (left) 303424-HD Fan assembly 303729 Foot lift lever 303854 Needle thread cover 303812 Sensor set *303783	AT006	AT056
L 32-36-3×4 38-3×4 70-5×5 86-5×6	Cloth plate 303758 Arm (left) 303424-FD Pulley cap assembly 303973 Foot lift lever 303854 Needle thread cover 303812 Pipe (upper) 303714 " " clamp 303708 Screw 5077 Sensor set *303823	AT007	AT057
<p>AT DEVICE COMPONENT PARTS →</p> <p>See page 66 for the gauge parts. Use the AT controller suitable to the power source.</p>		Tape cutter 303772 Solenoid assembly 811032 AT controller 100 V 760081 200 V 760082 220 V /240 V 760083 380 V /415 V 760084	Tape cutter 303772 Solenoid assembly 811032 Vacuum switching valve 303713 Dust drum 303747 AT controller 100 V 760081 200 V 760082 220 V /240 V 760083 380 V /415 V 760084

* = CP sensor



MACHINE TYPE · GAUGE	SPECIFIC PARTS	AT DEVICE TYPE	
		CONTINUOUS VACUUM TYPE	VACUUM SWITCHING TYPE
L 152-11, 12, 23-2×3 2×4 26, 27, 28×4	Cloth plate 303808 Arm (left) 303424-HD Fan assembly 303729 Foot lift lever 303854 Needle thread cover 303812 Sensor set *303782	AT008	AT058
L 152-13-2×3 2×4 17×4	Cloth plate 303810 Arm (left) 303424-HD Fan assembly 303729 Foot lift lever 303854 Needle thread cover 303812 Sensor set *303782	AT009	AT059
L 52-11, 12, 23-2×3 2×4 26, 27, 28×4	Cloth plate 303808 Arm (left) 303424-FD Pulley cap assembly 303973 Foot lift lever 303854 Needle thread cover 303812 Pipe (upper) 303714 " " clamp 303708 Screw 5077 Sensor set *303822	AT010	AT060
L 52-13-2×3 2×4 17×4	Cloth plate 303810 Arm (left) 303424-FD Pulley cap assembly 303973 Foot lift lever 303854 Needle thread cover 303812 Pipe (upper) 303714 " " clamp 303708 Screw 5077 Sensor set *303822	AT011	AT061
<p>↑</p> <p>AT DEVICE COMPONENT PARTS →</p> <p>See page 67 for the gauge parts. Use the AT controller suitable to the power source.</p>		Tape cutter 303774 Solenoid assembly 811032 AT controller 100 V 760081 200 V 760082 220 V /240 V 760083 380 V /415 V 760084	Tape cutter 303774 Solenoid assembly 811032 Vacuum switching valve 303713 Dust drum 303747 AT controller 100 V 760081 200 V 760082 220 V /240 V 760083 380 V /415 V 760084



MACHINE TYPE · GAUGE	SPECIFIC PARTS	AT DEVICE TYPE	
		WITHOUT VACUUM	
W61-01, 02, 06, 07 W41-01, 02, 04, 06, 07	Rear cover 306024 Cover (left) 306024 Rear cover 306969 Bed cover (left) 306969 Handwheel 306260	AT041	
W S 62-01, 02 W S 42-01, 02	Cloth plate 306617 Bed cover (left) 306588 Handwheel 307072-FD Face plate 306618 Chip cover 306589 Screw 1227	AT042	
<p>↑</p> <p>AT DEVICE COMPONENT PARTS →</p> <p>Use the AT controller suitable to the power source.</p>		Tape cutter 306263 Sensor set *306612 AT controller 100 V 760081 200 V 760082 220 V /240 V 760083 380 V /415 V 760084	

* = CP sensor



MACHINE TYPE · GAUGE	SPECIFIC PARTS	AT DEVICE TYPE	
		CONTINUOUS VACUUM TYPE	VACUUM SWITCHING TYPE
ETS32-430BA2, 432BA2, 452BA2, 453BA2 ETS32-420FA2, 432FA2, 432FC2/P1, 432FC2/P2, 542FD2 ETS52-141BA2-W, 142BA2/514-W, 350BC-W, 351BC-W ETS52-142FA2/514-W, 142FB2/514-W, 351FC2/P1-W, 351FC2/P2-W	Fan assembly 301274 Sensor set 301916 (MP sensor)	AT012	AT062
↑ AT DEVICE COMPONENT PARTS → See page 74~77 for the gauge parts. The cloth plate is not included in the component parts of the AT device.		Tape cutter 301751 Solenoid assembly 811025 AT controller 200V 760132	Tape cutter 301751 Solenoid assembly 811025 Vacuum switching valve 303713 Dust drum 303747 AT controller 200V 760132

MACHINE TYPE · GAUGE	SPECIFIC PARTS	AT DEVICE TYPE	
		CONTINUOUS VACUUM TYPE	VACUUM SWITCHING TYPE
E32-410-2×4, 411-3×4, 420-3×4, 430-3×4, -5×5, 450-5×6 E52-130/504-263-N4, 5, 6, 132-W2×3, 133-N2×3, 140-W2×4, 250-N2×3, 250C-W2×3	Fan assembly 301274 Sensor set 301916 (MP sensor)	AT021	AT071
↑ AT DEVICE COMPONENT PARTS → See page 65 for the gauge parts. The cloth plate is not included in the component parts of the AT device.		Tape cutter 301161 Solenoid assembly 811032 AT controller 200V 760132	Tape cutter 301161 Solenoid assembly 811032 Vacuum switching valve 303713 Dust drum 303747 AT controller 200V 760132

		AT DEVICE TYPE	
		WITHOUT VACUUM	
MACHINE TYPE · GAUGE	SPECIFIC PARTS		
E 32-410-2×4 420-3×4	Cloth plate 301157 Fan assembly 301274 Sensor set *301599	A T O 8 1	
E 32-411-3×4, 430-3×4, -5×5 450-5×6 E 52-132-W2×3, 140-W2×4 250 C, 252	Cloth plate 301143 Fan assembly 301274 Sensor set *301599	A T O 8 2	
E 52-130 133-N2×3 250	Cloth plate 301145 Fan assembly 301274 Sensor set *301599	A T O 8 4	
 AT DEVICE COMPONENT PARTS  See page 64 for the gauge parts. Use the AT controller suitable to the power source.		Tape cutter 301168 Solenoid assembly 811032	
		AT controller	
		100 V	760081
		200 V	760082
		220 V / 240 V	760083
		380 V / 415 V	760084

		AT DEVICE TYPE	
		WITHOUT VACUUM	
MACHINE TYPE · GAUGE	SPECIFIC PARTS		
L 132-36-3×4 38-3×4	Cloth plate 303802 Arm (left) 303424-HD Fan assembly 303729 Foot lift lever 303854 Needle thread cover 303812 Sensor set *303783	A T O 8 5	
L 132-70-5×5 86-5×6	Cloth plate 303800 Arm (left) 303424-HD Fan assembly 303729 Foot lift lever 303854 Needle thread cover 303812 Sensor set *303783	A T O 8 6	
L 32-36-3×4 38-3×4 70-5×5 86-5×6	Cloth plate 303432 Arm (left) 303424-FD Pulley cap assembly 303973 Foot lift lever 303854 Needle thread cover 303812 Pipe (upper) 303714 " " clamp 303708 Screw 5077 Sensor set *303823	A T O 8 7	
 AT DEVICE COMPONENT PARTS  See page 66 for the gauge parts. Use the AT controller suitable to the power source.		Tape cutter 303781 Solenoid assembly 811032	
		AT controller	
		100 V	760081
		200 V	760082
		220 V / 240 V	760083
		380 V / 415 V	760084

* = CP sensor

		AT DEVICE TYPE	
MACHINE TYPE · GAUGE		SPECIFIC PARTS	
		WITHOUT VACUUM	
L152-11, 12, 23-2×3 2×4 26, 27, 28×4	Cloth plate 303431 Arm (left) 303424-HD Fan assembly 303729 Foot lift lever 303854 Needle thread cover 303812 Sensor set *303782	A T 0 8 8	
L 152-13-2×3 2×4 17×4, ×5, ×6	Cloth plate 303433 Arm (left) 303424-HD Fan assembly 303729 Foot lift lever 303854 Needle thread cover 303812 Sensor set *303782	A T 0 8 9	
L 52-11, 12, 23-2×3 2×4 26, 27, 28×4, ×5, ×6	Cloth plate 303431 Arm (left) 303424-FD Pulley cap assembly 303973 Foot lift lever 303854 Needle thread cover 303812 Pipe (upper) 303714 " " clamp 303708 Screw 5077 Sensor set *303822	A T 0 9 0	
L 52-13-2×3 2×4 17×4, ×5, ×6	Cloth plate 303433 Arm (left) 303424-FD Pulley cap assembly 303973 Foot lift lever 303854 Needle thread cover 303812 Pipe (upper) 303714 " " clamp 303708 Screw 5077 Sensor set *303822	A T 0 9 1	
 AT DEVICE COMPONENT PARTS  See page 67 for the gauge parts. Use the AT controller suitable to the power source.		Tape cutter 303780 Solenoid assembly 811032	
		AT controller	
		100 V	760081
		200 V	760082
		220 V / 240 V	760083
		380 V / 415 V	760084

* = CP sensor



HOW TO SELECT CORRECT DEVICE TYPE AND PARTS (Tables 10-16)

You want to select the correct Device Type and you know the machine type that requires the Device.	➔	Choose the machine type in the column "MACHINE TYPE", and select the correct Device Type depending on your requirements.
You want to know the component parts of your Device Type.	➔	Check your Device Type in the column "DEVICE TYPE", and look for the COMPONENT PARTS.
You want to know the component parts in further detail.	➔	See pages 22-63.



Tab.10

		TK DEVICE TYPE		
MACHINE TYPE	SPECIFIC PARTS	ELECTRIC/PUSH BUTTON SWITCH	ELECTRIC/ KNEE SWITCH	PNEUMATIC/ KNEE SWITCH
E 32-410, 420	Cloth plate 301157	TK001 *(TKE-320)	TK031 *(TKE-320)	TK061 *(TKE-320)
E 32-411, 430, 440 450, 540, 541 542, 543 E 52-121, 136 130, 131, 132 134, 135, 140 220, 221, 240 241, 242, 243 250C, 261	Cloth plate 301143	TK002 *(TKE-320)	TK032 *(TKE-320)	TK062 *(TKE-320)
E 52-120, 130, 133 210, 210C, 211 250	Cloth plate 301145	TK003 *(TKE-320)	TK033 *(TKE-320)	TK063 *(TKE-320)
TK DEVICE COMPONENT PARTS ➔ See pages 69-70 for the gauge parts. Use the TK controller suitable to the power source.		Tape cutter 301168 Solenoid assembly 811032 Push button switch 303510 TK controller 100 V 760041 200-250 V 760040 380 V 760044	Tape cutter 301168 Solenoid assembly 811032 Knee switch 708004 Bracket assembly 303010 TK controller 100 V 760041 200-250 V 760040 380 V 760044	Tape cutter 301168 Air cylinder 513016 Control unit 605003



* = old name

		TK DEVICE TYPE		
MACHINE TYPE	SPECIFIC PARTS	ELECTRIC/PUSH BUTTON SWITCH	ELECTRIC/ KNEE SWITCH	PNEUMATIC/ KNEE SWITCH
L 132-05, 06, 07, 08 36, 37, 38, 39 40, 41	Cloth plate 303802	TK004 *(TKL-320)	TK034 *(TKL-320)	TK064 *(TKL-320)
L 132-30, 31, 32, 33, 48, 49, 70, 71, 78, 79, 86, 87	Cloth plate 303800	TK005 *(TKL-320)	TK035 *(TKL-320)	TK065 *(TKL-320)
L 32 L 22-02, 04 L 122-02, 04	Cloth plate 303432	TK009 *(TKL-320)	TK039 *(TKL-320)	TK069 *(TKL-320)
 TK DEVICE COMPONENT PARTS 		Tape cutter 303781 Solenoid assembly 811032 Push button switch 303510 Foot lift lever 303854 TK controller 100 V 760041 200~250 V 760040 380 V 760044	Tape cutter 303781 Solenoid assembly 811032 Knee switch 708004 Bracket assembly 303010 Foot lift lever 303854 TK controller 100 V 760041 200~250 V 760040 380 V 760044	Tape cutter 303781 Air cylinder 513016 Control unit 605003 Foot lift lever 303130



* = old name

		TK DEVICE TYPE		
MACHINE TYPE	SPECIFIC PARTS	ELECTRIC/PUSH BUTTON SWITCH	ELECTRIC/ KNEE SWITCH	PNEUMATIC/ KNEE SWITCH
L 152-03, 09, 11, 12 L 52 23, 24, 26, 27 28, 29, 31, 34 37, 51, 52, 53 54, 55, 56, 57 59, 18s4, 18ss	Cloth plate 303431	TK006 *(TKL-520)	TK036 *(TKL-520)	TK066 *(TKL-520)
L 152-01, 01S, 02, 05 L 52 13, 15, 17, 25	Cloth plate 303433	TK007 *(TKL-520)	TK037 *(TKL-520)	TK067 *(TKL-520)
 TK DEVICE COMPONENT PARTS  See pages 71-73 for the gauge parts. Use the TK controller suitable to the power source.		Tape cutter 303780 Solenoid assembly 811032 Push button switch 303510 Foot lift lever 303854 TK controller 100 V 760041 200~250 V 760040 380 V 760044	Tape cutter 303780 Solenoid assembly 811032 Knee switch 708004 Bracket assembly 303010 Foot lift lever 303854 TK controller 100 V 760041 200~250 V 760040 380 V 760044	Tape cutter 303780 Air cylinder 513016 Control unit 605003 Foot lift lever 303130

* = old name

MACHINE TYPE	SPECIFIC PARTS	TK DEVICE TYPE		
		ELECTRIC/PUSH BUTTON SWITCH	ELECTRIC/ KNEE SWITCH	PNEUMATIC/ KNEE SWITCH
R 53 (excludes) (R53-41, 49)	Cloth plate 300066 Arm (left) 300296-FD Feed bar cover 300297 Bed 300301	TK008 ※(TKR-530)	TK038 ※(TKR-530)	TK068 ※(TKR-530)
 TK DEVICE COMPONENT PARTS  See page 68 for the gauge parts. Use the TK controller suitable to the power source.		Tape cutter 300303 Solenoid assembly 811032 Push button switch 303510 TK controller 100V 760041 200~250V 760040 380V 760044	Tape cutter 300303 Solenoid assembly 811032 Knee switch 708004 Bracket assembly 303010 TK controller 100V 760041 200~250V 760040 380V 760044	Tape cutter 300303 Air cylinder 513016 Control unit 605003

※ = old name

MACHINE TYPE	SPECIFIC PARTS	TK DEVICE TYPE		
		ELECTRIC/ KNEE SWITCH	PNEUMATIC/ KNEE SWITCH	MANUAL TYPE
W61-01, 02, 05 W41-01, 02, 04	Rear cover 306024	TK041 ※(TKW-630)	TK070 ※(TKW-623)	/
WS 62-01, 02 WS 42-01, 02	Bed cover 306588-FD Chip cover 306589 Screw 1227	TK042 ※(TKW-630)	TK071 ※(TKW-623)	/
WS 62-05 WS 42-05	Bed cover 306613-FD Chip cover 306589 Screw 1227	TK043 ※(TKW-630)	TK072 ※(TKW-623)	/
W61-01, 02, 05 W41-01, 02, 04	Rear cover 306724-FD	/	/	TK090 ※(TK4)
WS 62-01, 02 WS 42-01, 02	Bed cover 306725-FD	/	/	TK091 ※(TK4)
W41-01/UT, 02/UT	Rear cover 306726-FD	/	/	TK092 ※(TK4)
WS 42-01/UT, 02/UT	Bed cover 306727-FD	/	/	TK093 ※(TK4)
 TK DEVICE COMPONENT PARTS 		Tape cutter 306263 Knee switch 708004 Bracket assembly 303010 TK controller 100V 760041 200~250V 760040 380V 760044	Tape cutter 306590 Control unit 605003	Tape cutter 306712 Pedal 478

※ = old name

MACHINE TYPE	TK DEVICE TYPE		
	ELECTRIC/PUSH BUTTON SWITCH	ELECTRIC/ KNEE SWITCH	PNEUMATIC/ KNEE SWITCH
ETS 32 ETS 52	TKO10	TKO11	TKO12
<p style="text-align: center;">↑</p> <p>TK DEVICE COMPONENT PARTS →</p> <p>The cloth plate is not included in the component parts of the TK device.</p>	Tape cutter 301749 Solenoid assembly 811025 Push button switch 303510 TK controller 100V 760041 200~250V 760040 380V 760044	Tape cutter 301749 Solenoid assembly 811025 Knee switch 708004 Bracket assembly 303010 TK controller 100V 760041 200~250V 760040 380V 760044	Tape cutter 301749 Air cylinder 513044 Control unit 605003

MACHINE TYPE	TK DEVICE TYPE		
	ELECTRIC/PUSH BUTTON SWITCH	ELECTRIC/ KNEE SWITCH	PNEUMATIC/ KNEE SWITCH
L152-18s4,18s5 L52-18s4,18s5	TKO17	TKO18	TKO19
<p style="text-align: center;">↑</p> <p>TK DEVICE COMPONENT PARTS →</p> <p>See page 72 for the gauge parts. Use the TK controller suitable to the power source.</p>	Tape cutter 304071 Solenoid assembly 811032 Push button switch 303510 Foot lift lever 303854 TK controller 100V 760041 200~250V 760040 380V 760044	Tape cutter 304071 Solenoid assembly 811032 Knee switch 708004 Bracket assembly 303010 Foot lift lever 303854 TK controller 100V 760041 200~250V 760040 380V 760044	Tape cutter 304071 Air cylinder 513016 Control unit 605003 Foot lift lever 303130

DEVICE IDENTIFICATION (Example : AT Device)

Each Device and its Auxiliary Device is identified as follows.

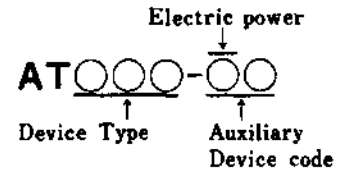

DEVICE TYPE

The Device Type is identified by the DEVICE COMPONENT PARTS. See Tables 1-16. These parts consist of the parts which are necessary to set the Device on the machine, and the parts which control or activate the Device.

AUXILIARY DEVICE CODE

The Auxiliary Device code is classified according to the electric power and the component parts. See Table 18.

ELECTRIC POWER CODE

Electric Power code is identified by the voltage and the phase. See Table 17.

ELECTRIC POWER CODE Tab.17

CODE	VOLTAGE	PHASE
0	---	-
1	100V	1
2	200V	3
3	220V	3
4	240V	3
5	380V	3
6	415V	3
7	220V	1
8	240V	1

EXAMPLE

AT051-2A

Automatic vacuum switching AT Device
for E32-410 (E32-420).
(See Table 1 on page 12 in detail)

Equipped with 50Hz Blower Device.
3 phase, 200V.
(See Table 17 in detail)

REFERENCE TABLE FOR AT DEVICES AND AUXILIARY DEVICES

Specify the voltage of the Controller. Tab.18

CODE OF AUXILIARY DEVICE		1A	1B	2A	2B	1C	1D	2C	2D	1E	1F	2E	2F	OG Old: VSA-200
ELECTRICITY	Phase	1P	1P	3P	3P	1P	1P	3P	3P	1P	1P	3P	3P	Compressed air is required.
	Voltage	100V	100V	200V	200V	100V	100V	200V	200V	100V	100V	200V	200V	
COMPONENT PARTS	Current	50Hz	60Hz	50Hz	60Hz	50Hz	60Hz	50Hz	60Hz	50Hz	60Hz	50Hz	60Hz	
	* Blower Device	500007	500005	500008	500006	500007	500005	500008	500006	500007	500005	500008	500006	300207 Venturi Device
	Waste Receptacle	---	---	---	---	300305	300305	300305	300305	---	---	---	---	
Dust Drum	---	---	---	---	---	---	---	---	303747	303747	303747	303747		
AT DEVICE TYPE		AT051~AT071				AT001~AT021				AT001~AT021				AT001~AT021
REMARKS		Air is automatically switched from sucking thread chain/tape to sucking the trimmings of the fabric or vice-versa. Dust Drum is included in the AT Device.				For cutting thread chain. Air is continuously sucked.				For cutting thread chain/tape. Air is continuously sucked.				For cutting thread chain.

*See pages 50, 51.

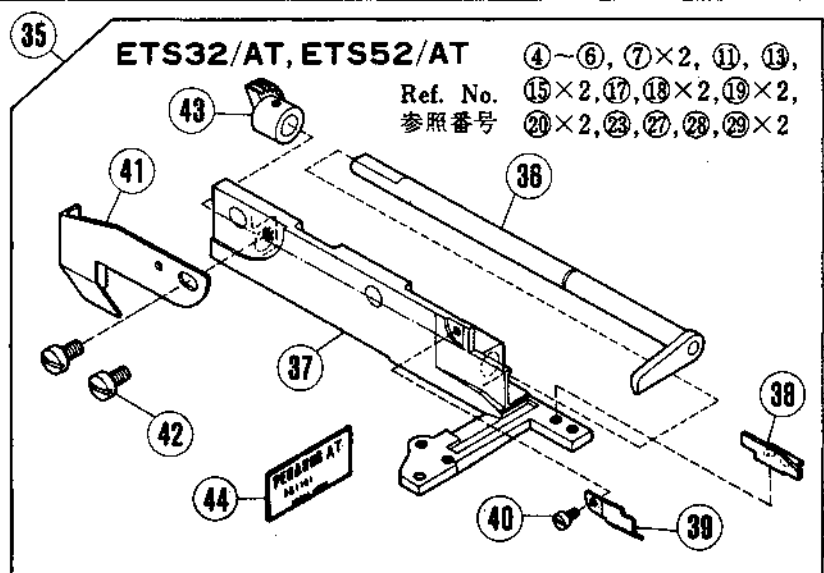
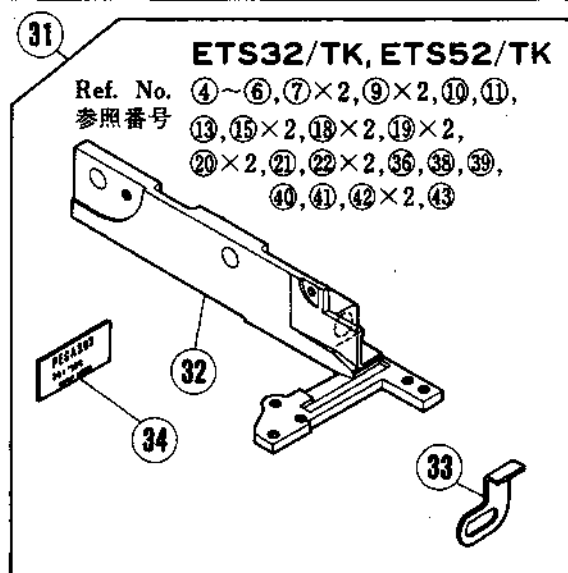
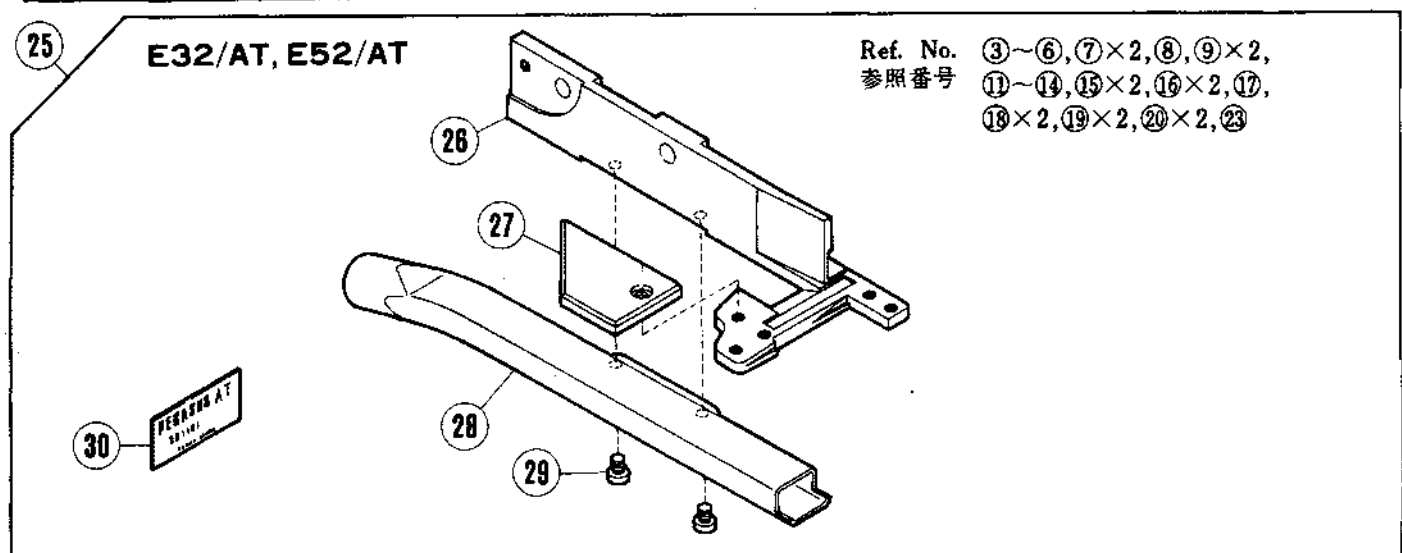
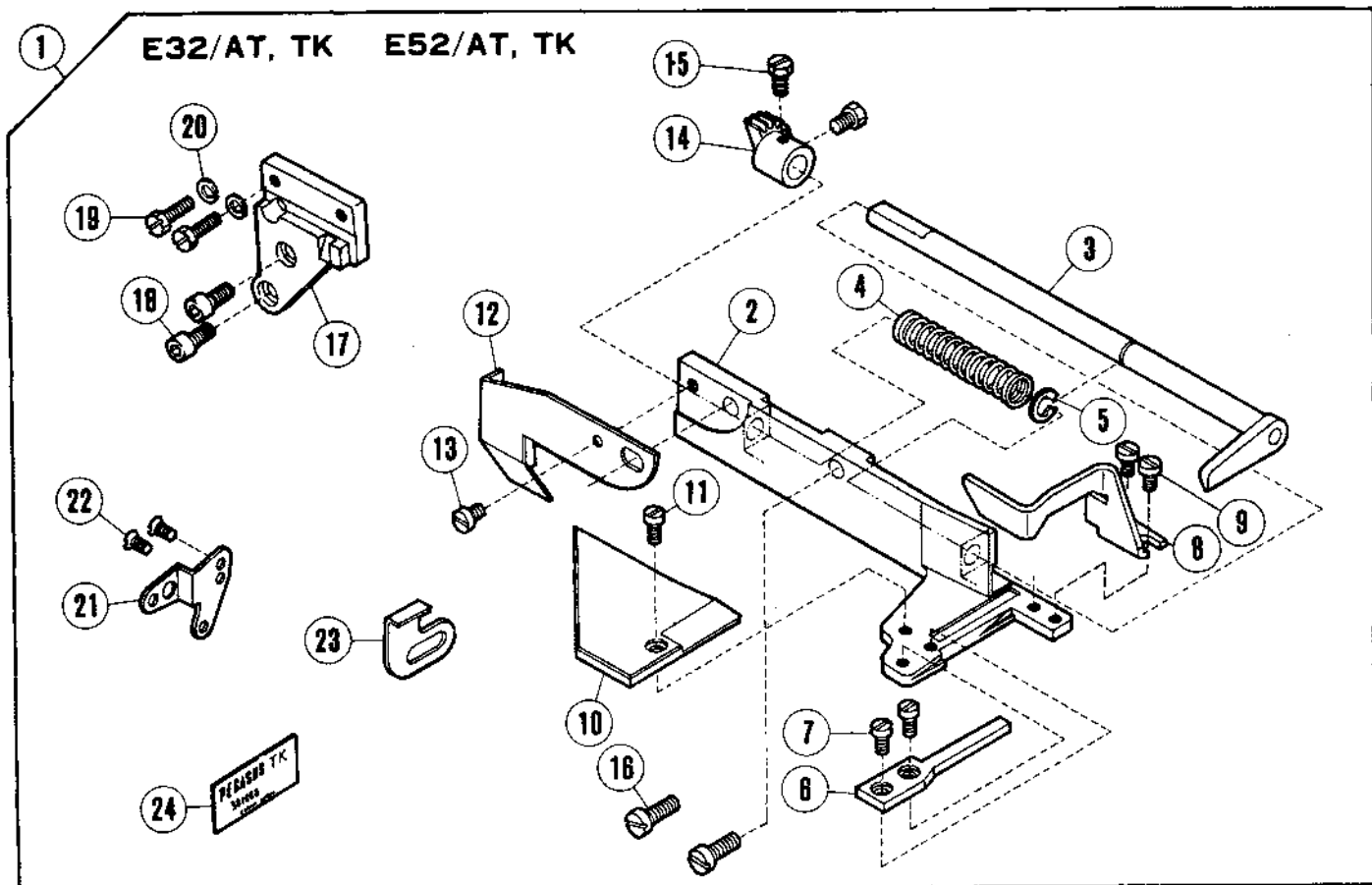

テープカッター
(E32, E52, ETS32, ETS52用)

TAPE CUTTER
(FOR E32, E52, ETS32, ETS52)

REF. NO.	PART NO.	NAME	QT.
	7*ハ*ン	メイヨウ	
1	301168	テーブカッター(クミ)	1
2	303020	フレーム	1
3	303131	ウツハ(クミ)	1
4	303096	アツユクハネ	1
5	303097	トメワ	1
6	301138	シタハ	1
7	1186-HC	ヒラネシ/C3	2
8	302098	コロモヨク	1
9	1186-HC	ヒラネシ/C3	2
10	302197	スハ*リイタ	1
11	1186	ヒラネシ/C3	1
12	303063	ギ*アカバー	1
13	1186	ヒラネシ/C3	1
14	301165	ピ*ニオン	1
15	5084	ロツカクネシ/C5	2
16	5345	ヒラネシ/C5	2
17	301167	ブ*ラケツト	1
18	5381	ヒラネシ/C10	2
19	5276	ロツカクネシ/C7	2
20	303067	ハ*ネサ*カ*ネ	2
21	301139	ブ*ラケツト	1
22	3001	サラネシ/C5	2
23	301048	ホシ*ヨイタ	1
24	301332	メイハシ	1
25	301161	テーブカッター(クミ)	1
26	301163	フレーム	1
27	301164	スハ*リイタ	1
28	301160	ハ*イブ(クミ)	1
29	1186	ヒラネシ/C3	2
30	301329	メイハシ	1
31	301749	テーブカッター(クミ)	1
32	301643	フレーム	1
33	301118	クロソフ*レート ホシ*ヨイタ	1
34	301753	メイハシ	1
35	301751	テーブカッター(クミ)	1
36	301637	ウツハ(クミ)	1
37	301643	フレーム	1
38	301638	コロモヨク(フイ)	1
39	301639	コロモヨク(ウシロ)	1
40	5077	ヒラネシ	1
41	301641	ギ*アカバー	1
42	5117	ヒラネシ/C5	2
43	301642	ピ*ニオン	1
44	301754	メイハシ	1

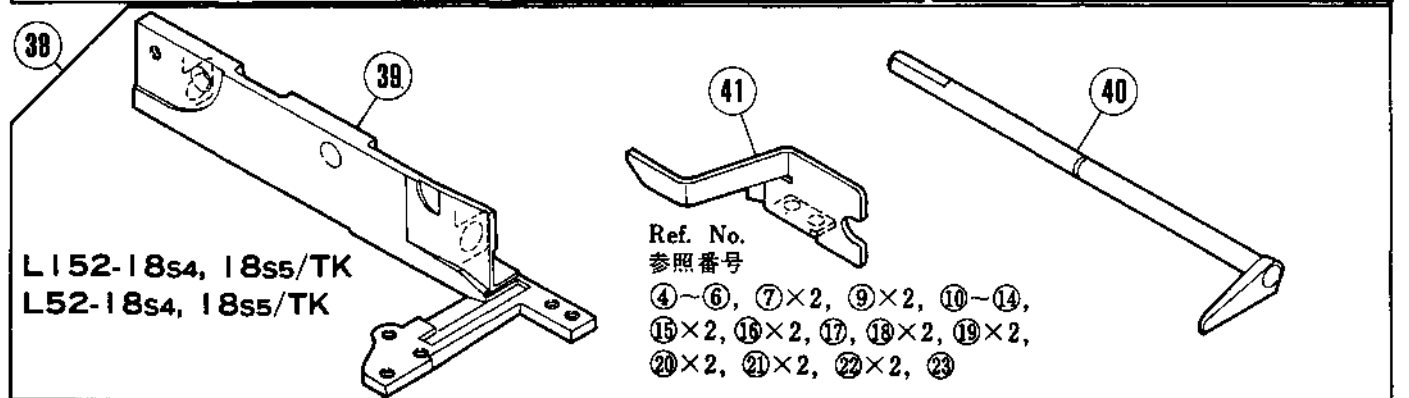
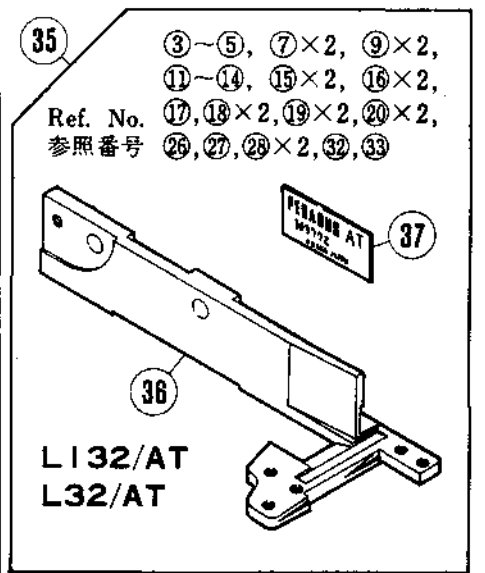
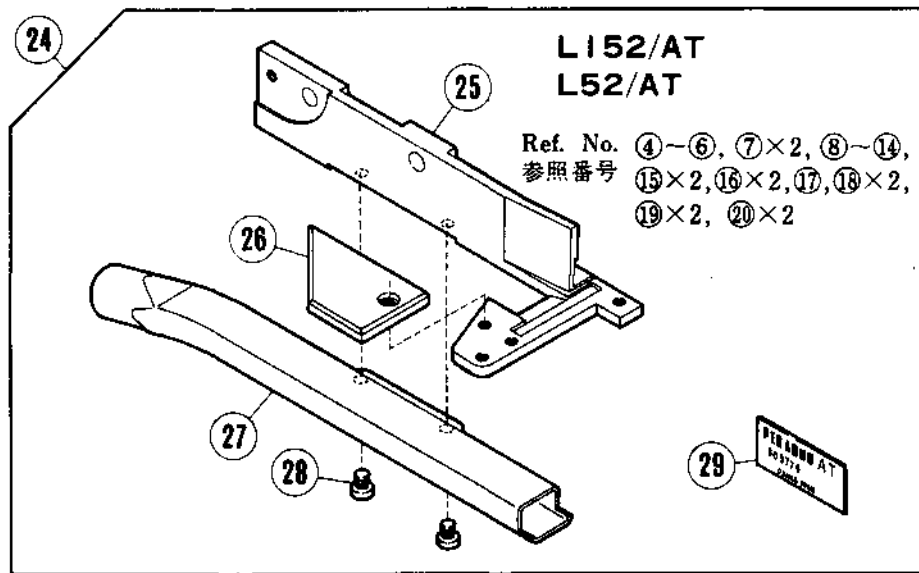
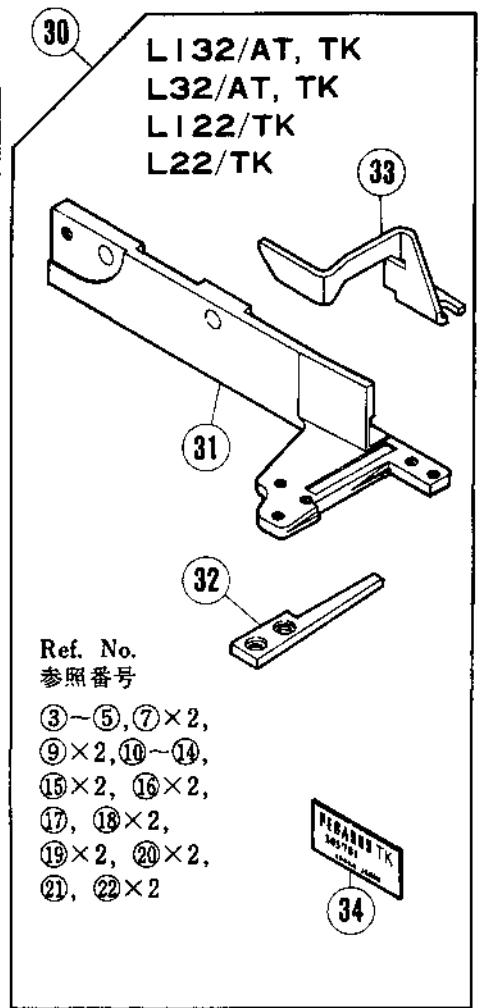
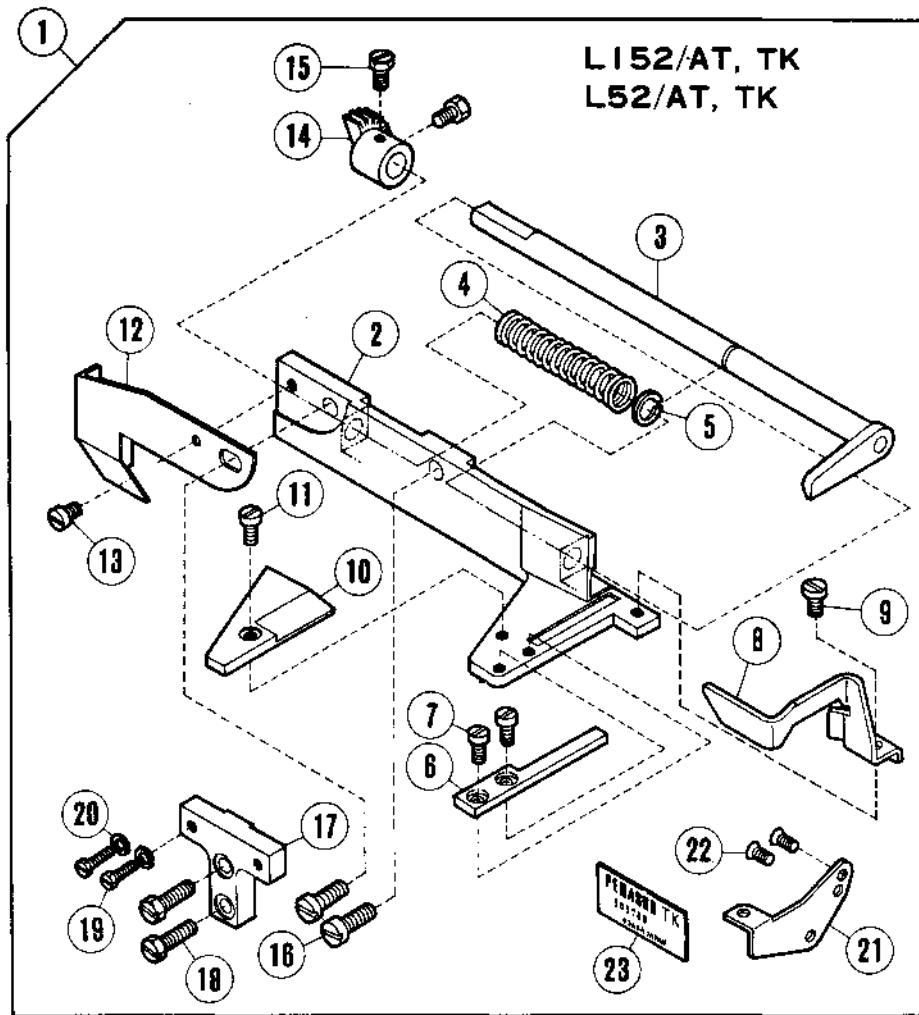

テープカッター(Lシリーズ用)

TAPE CUTTER (FOR L SERIES)

REF. NO.	PART NO.	メイショウ	NAME	QT.
1	303780	テーブカッター(クミ)	TAPE CUTTER ASSEMBLY	1
2	303141	フレーム	FRAME	1
3	303131	ウツハ(クミ)	MOVABLE BLADE	1
4	303096	アツシユクハネ	SPRING	1
5	303097	トメワ	RING	1
6	300006	シタハ	STATIONARY BLADE	1
7	1186-HC	ヒラネシ/C3	SCREW	2
8	304064	コロモヨク	FABRIC GUARD	1
9	1186	ヒラネシ/C3	SCREW	1
10	304044	スハリイタ	SLIDING PLATE	1
11	1136-HC	ヒラネシ	SCREW	1
12	303063	キヤカハ	FABRIC GUARD	1
13	1186	ヒラネシ/C3	SCREW	1
14	301165	ヒニオン	PINION	1
15	5084	ロツカクネシ/C5	SCREW	2
16	5345	ヒラネシ/C5	SCREW	2
17	303013	ブラケット	BRACKET	1
18	5266	ロツカクネシ/C8	SCREW	2
19	5276	ロツカクネシ/C7	SCREW	2
20	303067	ハネサカネ	WASHER	2
21	303426	ブラケット	BRACKET	1
22	3001	サラネシ/C5	SCREW	2
23	303853	メイハク	NAME PLATE	1
24	303774	テーブカッター(クミ)	TAPE CUTTER ASSEMBLY	1
25	303776	フレーム	FRAME	1
26	301164	スハリイタ	PLATE	1
27	301160	パイプ(クミ)	PIPE	1
28	1186	ヒラネシ/C3	SCREW	2
29	303849	メイハク	NAME PLATE	1
30	303781	テーブカッター(クミ)	TAPE CUTTER ASSEMBLY	1
31	303020	フレーム	TAPE CUTTER	1
32	303021	シタハ	STATIONARY BLADE	1
33	302098	コロモヨク	FABRIC GUARD	1
34	303852	メイハク	NAME PLATE	1
35	303772	テーブカッター(クミ)	TAPE CUTTER ASSEMBLY	1
36	301163	フレーム	FRAME	1
37	303848	メイハク	NAME PLATE	1
38	304071	テーブカッター(クミ)	TAPE CUTTER ASSEMBLY	1
39	304072	フレーム	FRAME	1
40	304073	ウツハ	MOVABLE BLADE	1
41	304076	コロモヨク	FABRIC GUARD	1

1

R53/TK

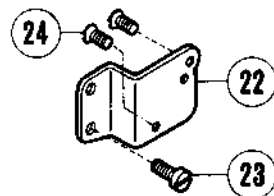
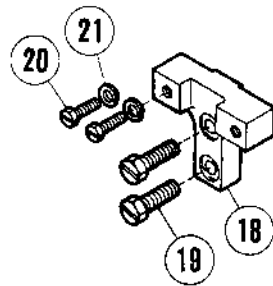
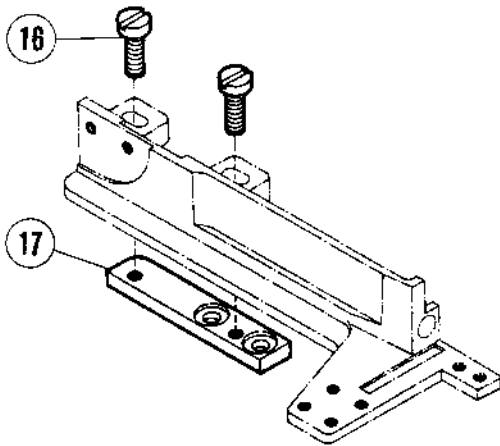
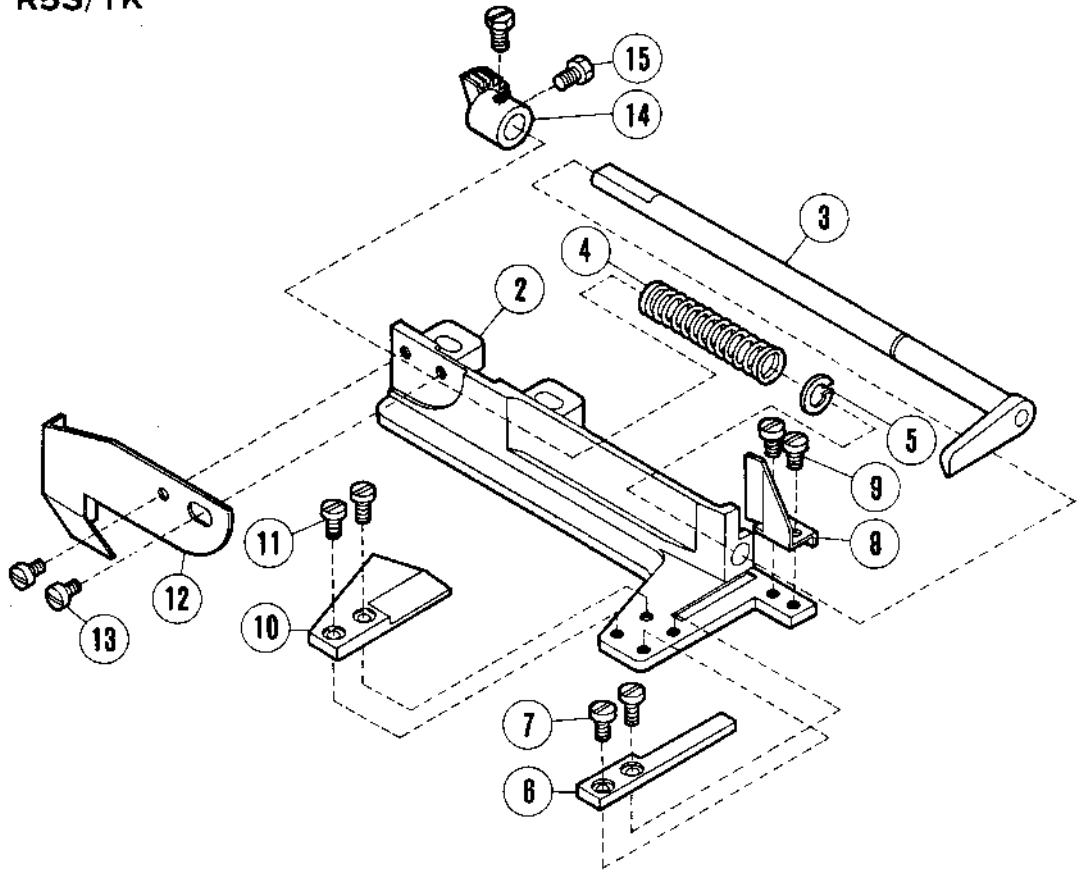

テープカッター(R53用)

TAPE CUTTER (FOR R53)

REF. NO.	PART NO.	メイショウ	NAME	QT.
1	300303	テーブカッター(クミ)	TAPE CUTTER SET	1
2	300001	フレーム	FRAME	1
3	300003	ウツハ(クミ)	MOVABLE BLADE	1
4	303096	アツシユクハネ	SPRING	1
5	303097	トメワ	RING	1
6	300006	シタハ	STATIONARY BLADE	1
7	1186-HC	ヒラネシ/C3	SCREW	2
8	300008	コモヨク	FABRIC GUARD	1
9	1186	ヒラネシ/C3	SCREW	1
10	300011	スヘリイタ	PLATE	1
11	1186-HC	ヒラネシ/C3	SCREW	2
12	303063	キヤカハ	FABRIC GUARD	1
13	2921	ヒラネシ/C3	SCREW	2
14	301165	ヒニオン	PINION	1
15	5084	ロツカクネシ/C5	SCREW	2
16	2902	ヒラネシ/C5	SCREW	2
17	300002	ブラケット	BRACKET	1
18	300299	ブラケット	BRACKET	1
19	5266	ロツカクネシ/C8	SCREW	2
20	5276	ロツカクネシ/C7	SCREW	2
21	303067	ハネサカネ	WASHER	2
22	300140	ブラケット	BRACKET	1
23	5113	ヒラネシ/C5	SCREW	1
24	3001	サラネシ/C5	SCREW	2
25	300306	メイハシ (TK)	NAME PLATE (TK)	1

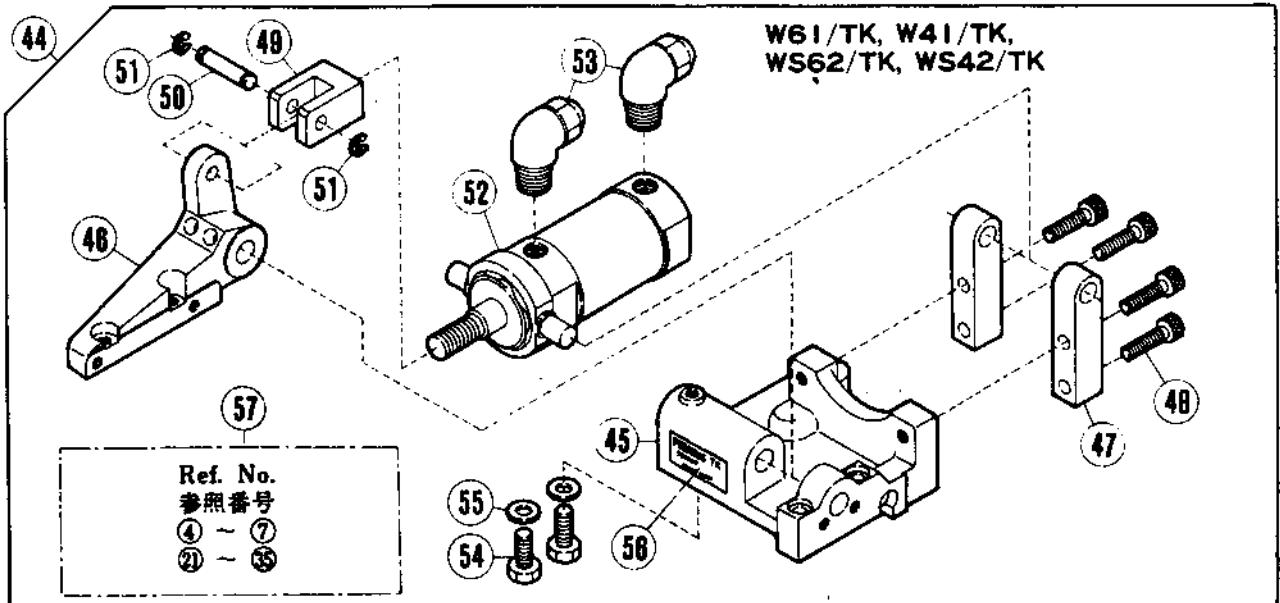
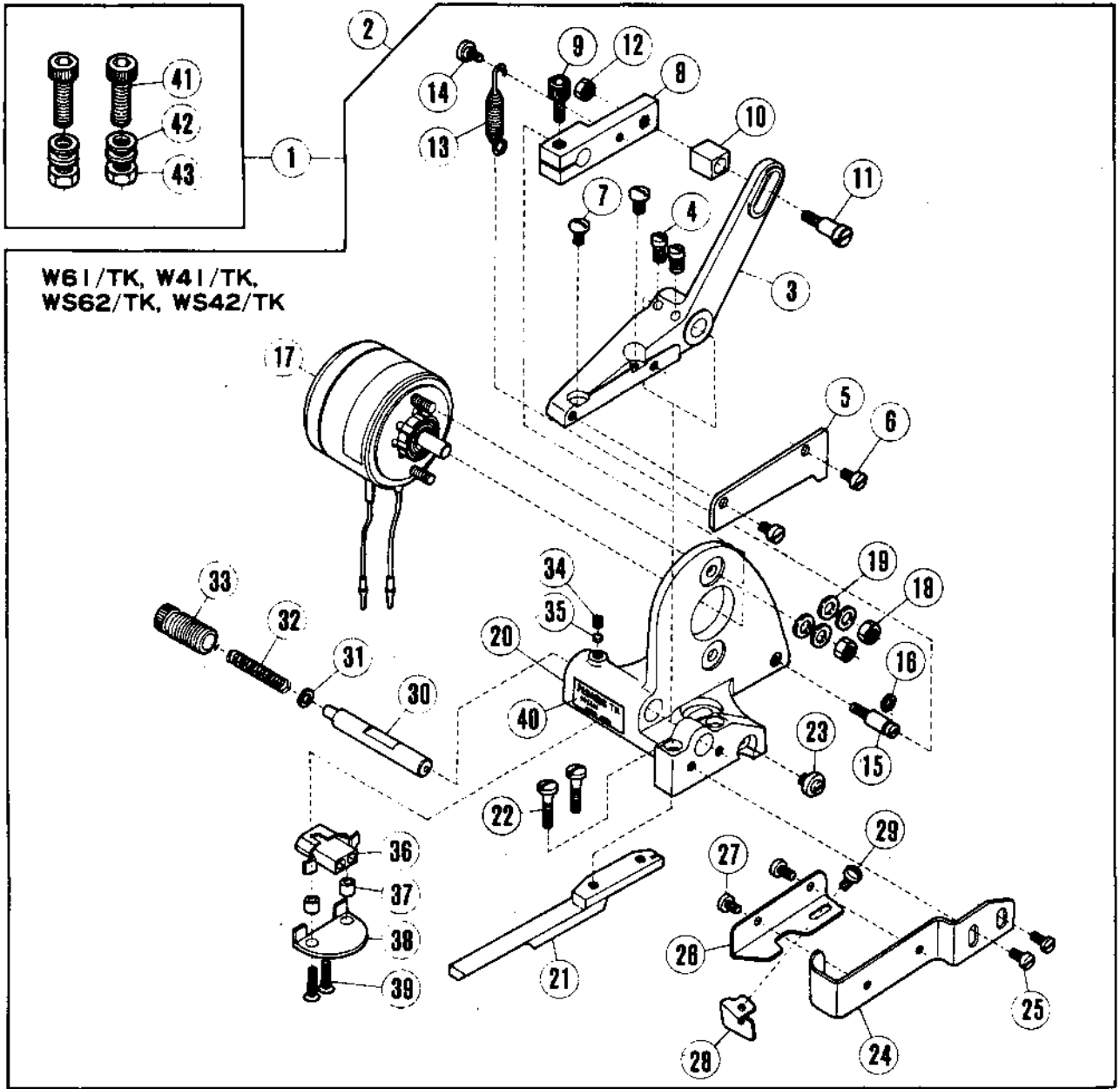

テープカッター(1)
(W, WSシリーズ用)

TAPE CUTTER(1)
(FOR W, WS SERIES)

REF. NO.	PART NO.	メイヨウ	NAME	QT.
1	306263	テープカッター(クミ)	TAPE CUTTER ASSEMBLY	1
2	306026	ワレム(クミ)	WASHER	1
3	306006	サトウウテ	DRIVE LEVER	1
4	5059	ヒラネシ/C8	SCREW	2
5	306002	ウツハ	MOVABLE BLADE	1
6	5116	ヒラネシ/C7	SCREW	2
7	5214	ヒラネシ/C7	SCREW	2
8	306008A	レバ	LEVER	1
9	5381	ヒラネシ/C10	SCREW	1
10	306012	カクコブ	BLOCK	1
11	5403	タコツキネシ/C9	SCREW	1
12	3018	ワカクナツト/C9	NUT	1
13	306025	ヒツパリハネ	SPRING	1
14	5422	タコツキネシ/C5	SCREW	1
15	306010	ヒコツキネシ	PIN-SCREW	1
16	306011	トメワ	RING	1
17	811006	ソレノイド(クミ)	SOLENOID UNIT	1
18	4806	ワカクナツト/M6	NUT	2
19	202433	サカネ	WASHER	4
20	306001	ワレム	FRAME	1
21	306021	シタハ	STATIONARY BLADE	1
22	5189	ヒラネシ/C7	SCREW	2
23	5324	タコツキネシ/C4	SCREW	1
24	306016	アセツカハ	SAFETY COVER	1
25	4009-1	ヒラネシ/C5	SCREW	2
26	306022	クロモアツナイ(タコ)	CLOTH GUIDE (LARGE)	1
27	5077	ヒラネシ	SCREW	2
28	306023	クロモアツナイ(シヨウ)	CLOTH GUIDE (SMALL)	1
29	2921	ヒラネシ/C3	SCREW	1
30	306003	シク	SHAFT	1
31	204115	サカネ	THRUST WASHER	1
32	306004	アツシユツカハネ	SPRING	1
33	306005	チヨウセツネシ	THUMB SCREW	1
34	1457	トメネシ/C5	SCREW	1
35	306013	ワツク	LOCK	1
36	752005	コネクター(オス)	CONNECTOR (MALE)	1
37	306015	スヘーサー	SPACER	2
38	306014	ワラケツト	BRACKET	1
39	5230	サラネシ/C5	SCREW	2
40	306685	メイハシ	NAME PLATE	1
41	4503	ヒラネシ	SCREW	2
42	202433	サカネ	WASHER	4
43	4806	ワカクナツト/M6	NUT	2
44	306590	テープカッター(クミ)	TAPE CUTTER ASSEMBLY	1
45	306583-FD	ワレム	FRAME	1
46	306584-FD	ワラケツト	BRACKET	1
47	306585	トラニオン シクツク	TRUNNION BEARING	2
48	4516	ヒラネシ	SCREW	4
49	306586	ナツク	KNUCKLE	1
50	306587	エイコウピン	PIN	1
51	303097	トメワ	RING	2
52	513015	エアシリンダ	AIR CYLINDER	1
53	601033	ツキテ	CONNECTOR	2
54	4304	ワカクネシ/M6	SCREW	2
55	202433	サカネ	WASHER	2
56	306620	メイハシ	NAME PLATE	1

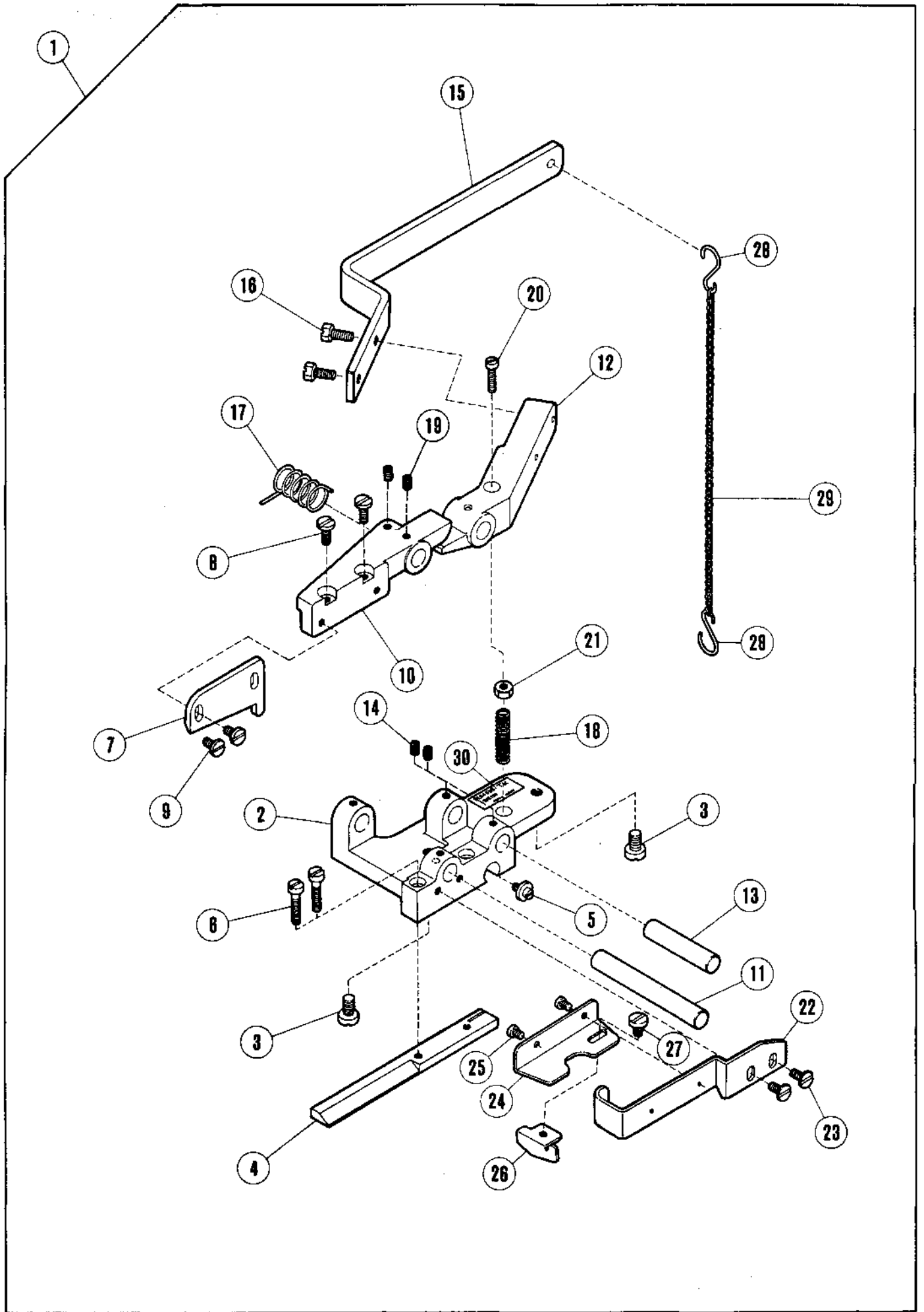

テープカッター(2)
(W, WSシリーズ用)

TAPE CUTTER(2)
(FOR W, WS SERIES)

REF. NO.	PART NO.	名称	NAME	QT.
1	306712	テープカッター(クミ)	TAPE CUTTER ASSEMBLY	1
2	306713-FD	フレーム	FRAME	1
3	5357	ヒラネジ/C9	SCREW	2
4	306714	固定刀	STATIONARY BLADE	1
5	5324	タツキネジ/C4	SCREW	1
6	5095	ヒラネジ/C5	SCREW	2
7	306715	可動刀	MOVABLE BLADE	1
8	5345	ヒラネジ/C5	SCREW	2
9	4009-1	ヒラネジ/C5	SCREW	2
10	306716-FD	ブラケット	BRACKET	1
11	306717	シャフト	SHAFT	1
12	306718-FD	レバー	LEVER	1
13	306719	シャフト	SHAFT	1
14	5461	トメネジ/C5	SCREW	2
15	306720	レバー	LEVER	1
16	5275	ロツカクネジ/C7	SCREW	2
17	306721	ネジリハネ	SPRING	1
18	306004	アツシユクハネ	SPRING	1
19	5461	トメネジ/C5	SCREW	2
20	5183	ヒラネジ/C5	SCREW	1
21	3044	ロツカクナツ/C5	NUT	1
22	306016	アセツカハネ	SAFETY COVER	1
23	4009-1	ヒラネジ/C5	SCREW	2
24	306722	コモアツナイ(大)	CLOTH GUIDE (LARGE)	1
25	5077	ヒラネジ	SCREW	2
26	306723	コモアツナイ(小)	CLOTH GUIDE (SMALL)	1
27	2921	ヒラネジ/C3	SCREW	1
28	306735	フック	HOOK	2
29	125	チェーン(ヒラ)	CHAIN	1
30	306619	メイト	NAME PLATE	1

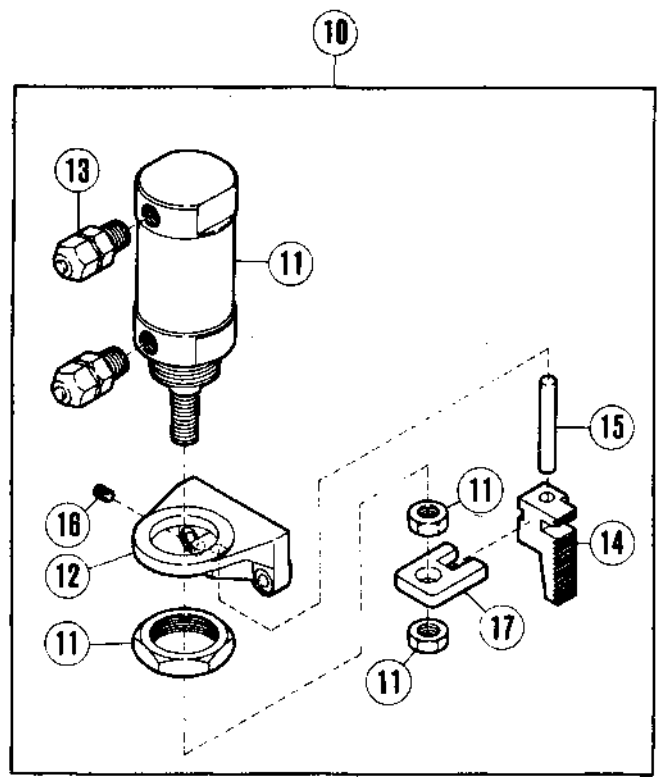
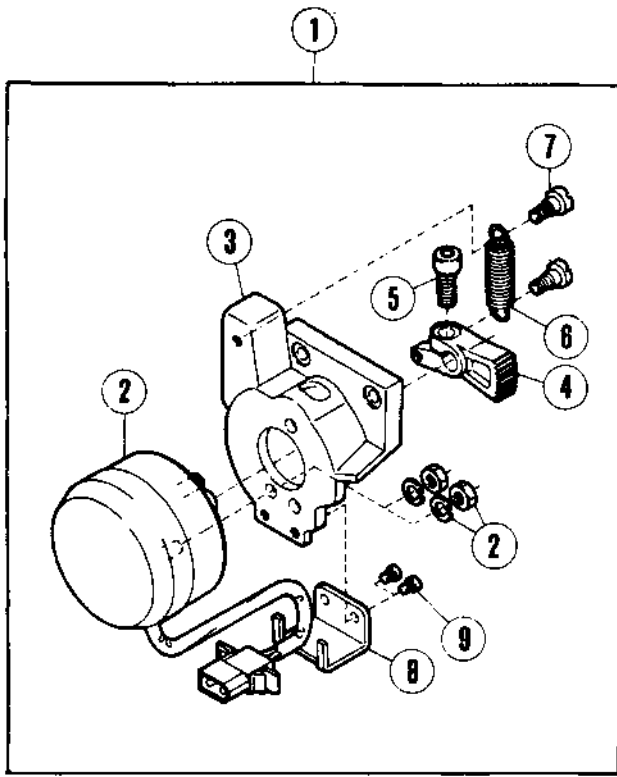

18

ETS32•ETS52

20

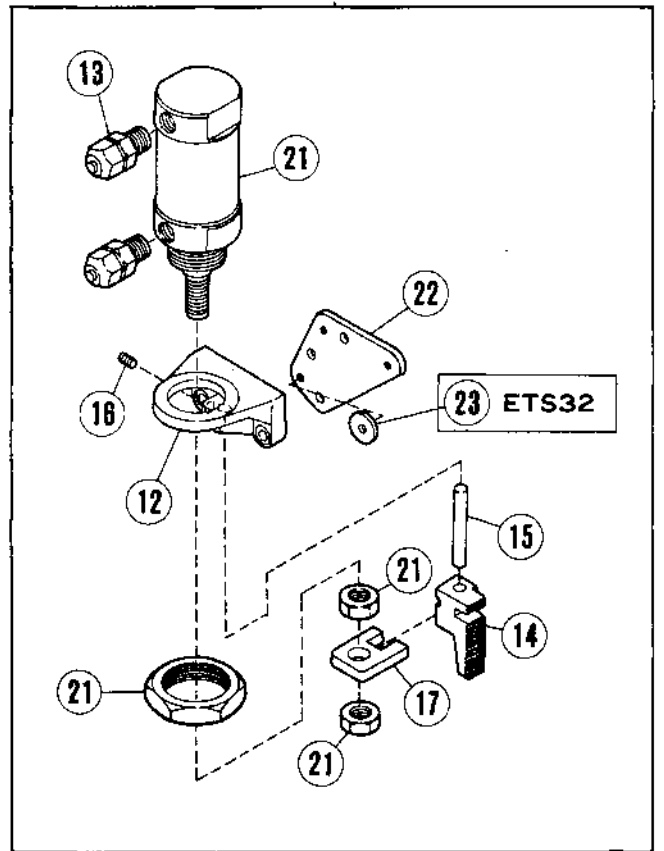
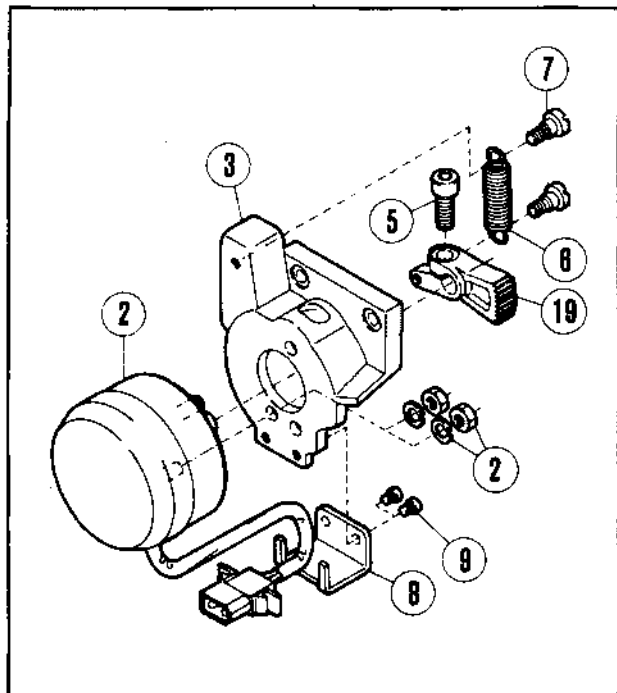

ソレノイド/エアシリンダー

SOLENOID/AIR CYLINDER

REF. NO.	PART NO.	メイヨウ	NAME	QT.
1	811032	ソレノイド*(クミ)	SOLENOID ASSEMBLY	1
2	811033	ソレノイド*	SOLENOID	1
3	301170-HD	ブラケット	BRACKET	1
4	301171	ギア-	GEAR	1
5	5457	ビスネジ/C9	SCREW	1
6	301172	ヒツパ リバネ	SPRING	1
7	5422	タツキネジ/C5	SCREW	2
8	301173	ブラケット	BRACKET	1
9	5053	ビスネジ/C4	SCREW	2
10	513016	エアシリンダ*(クミ)	AIR CYLINDER ASSEMBLY	1
11	513017	エアシリンダ*	AIR CYLINDER	1
12	301245	ブラケット	BRACKET	1
13	601042	ツキテ	CONNECTOR	2
14	301246	ラック	RACK	1
15	301247	シャフト	SHAFT	1
16	5185	ビスネジ/C8	SCREW	1
17	301248	ドライブレバー	DRIVE LEVER	1
18	811025	ソレノイド*(クミ)	SOLENOID ASSEMBLY	1
19	301640	ギア	GEAR	1
20	513044	エアシリンダ*(クミ)	AIR CYLINDER ASSEMBLY	1
21	513045	エアシリンダ*	AIR CYLINDER	1
22	302199	ブラケット	BRACKET	1
23	200098	ワッシャ	WASHER	1

1	2	18	41	52	55
4	5	10	18	33	51
47	28	48	49	50	53

共通パーツ
COMMON PARTS
6 ~ 46

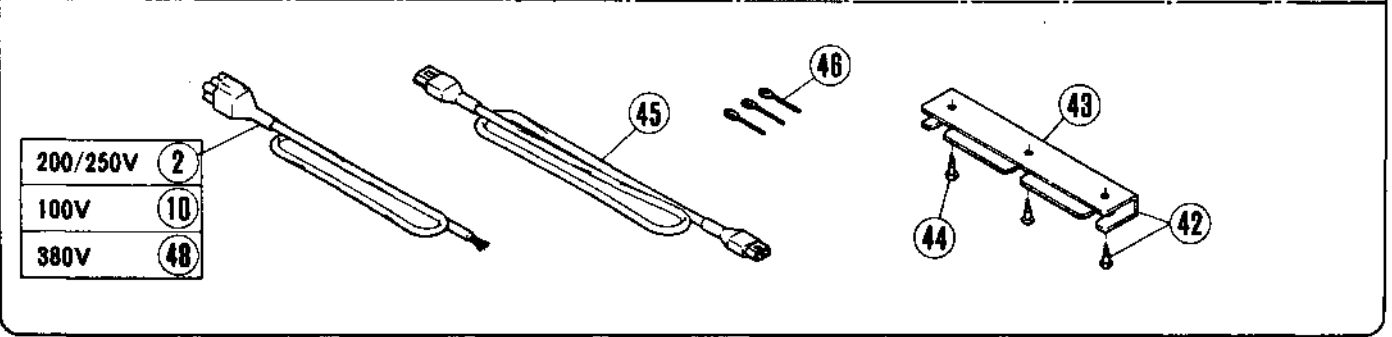
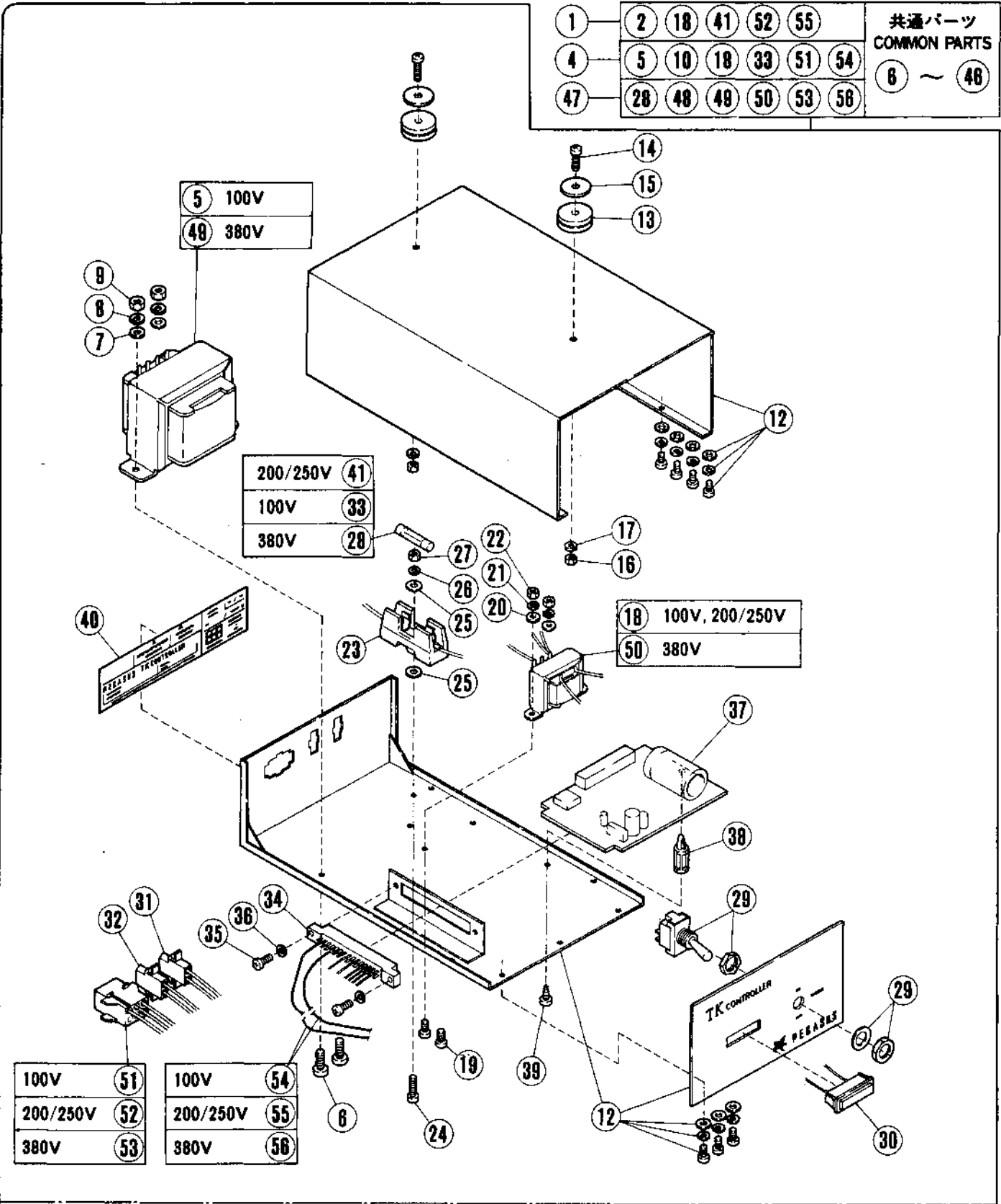

TKコントローラー

TK CONTROLLER

REF. NO.	PART NO.	メキシコ	NAME	QT.
1	760040	TKコントローラー(200/250V)	TK CONTROLLER (200/220V)	1
2	742075	テックジャンクション	JUNCTION CORD/PUSH BUTTON	1
4	760041	TKコントローラー(100V)	TK CONTROLLER (100V)	1
5	790001	オートトランスAT01	AUTO TRANSFORMER	1
6	4122	ヒラネジ	SCREW	2
7	303448	ワッシャー	WASHER	2
8	300291	ハネサワッシャー	SPRING WASHER	2
9	4804	ロツカクナツト	NUT	2
10	742076	テックジャンクション100V	POWER SOURCE CORD/100V	1
12	760042	ケース	CASE	1
13	202013	ヌノオガイゴム	FABRIC GUIDE RUBBER	2
14	4107	ヒラネジ/M4	SCREW	2
15	303026	ワッシャー	WASHER	2
16	4802	ナツト(M4)	NUT	2
17	201252	ハネサワッシャー	SPRING WASHER	2
18	791008	トランスTK01	TRANSFORMER	1
19	4119	ヒラネジ	SCREW	2
20	303550	ワッシャー	WASHER	2
21	204586	ハネサワッシャー	SPRING WASHER	2
22	4800	ロツカクナツト/M3	NUT	2
23	772002	ヒューズホルダー	FUSE HOLDER	1
24	4105	ヒラネジ	SCREW	1
25	303550	ワッシャー	WASHER	2
26	204586	ハネサワッシャー	SPRING WASHER	1
27	4800	ロツカクナツト/M3	NUT	1
28	771003	ヒューズ(1A)	FUSE/1A	2
29	701008	テックコンスイッチ	MAIN SWITCH	1
30	783001	ネオンランプ	NEON LAMP	1
31	742136	スイッチユウリョクケーブル	SWITCH CABLE	1
32	742137	ソレノイドユウリョクケーブル	CABLE/SOLENOID	1
33	771004	ヒューズ(3A)	FUSE/3A	2
34	752024	コネクタ/コントロールボード-15P	CONNECTOR/CONTROL BOARD	1
35	4104	ヒラネジ	SCREW	2
36	204586	ハネサワッシャー	SPRING WASHER	2
37	745022	プリント基板(クミ)	PRINT CIRCUIT BOARD ASSEMBLY	1
38	748011	タッピングサポート	TAPPING SUPPORT	1
39	4118	ヒラネジ/M4	SCREW	1
40	301498	ヒョウシプレート	INDICATION PLATE	1
41	771001	ヒューズ(2A, 250V)	FUSE	2
42	303500	ブラケット(クミ)	BRACKET ASSEMBLY	1
43	303499	ブラケット	BRACKET	1
44	4911	モクネジ	SCREW	3
45	742044	テックジャンクション/TK	EXTENSION CORD/TK	1
46	748004	ヒューズバンド	BAND	3
47	760044	TKコントローラー(380V)	TK CONTROLLER (380V)	1
48	742087	テックジャンクション(380V)	POWER SOURCE CORD (380V)	1
49	790003	オートトランスAT03	AUTO TRANSFORMER	1
50	791022	トランスTK12	TRANSFORMER/TK12	1
51	742085	テックジャンクションユウリョクケーブル	POWER INPUT CABLE	1
52	742143	テックジャンクションユウリョクケーブル	POWER SOURCE CABLE	1
53	742107	テックジャンクションユウリョクケーブル	POWER INPUT CABLE (380V)	1
54	742139	ACワイヤリード	AC WIRING LEAD	1
55	742138	ACワイヤリード	AC WIRING LEAD	1
56	742144	ACワイヤリード	AC WIRING LEAD	1

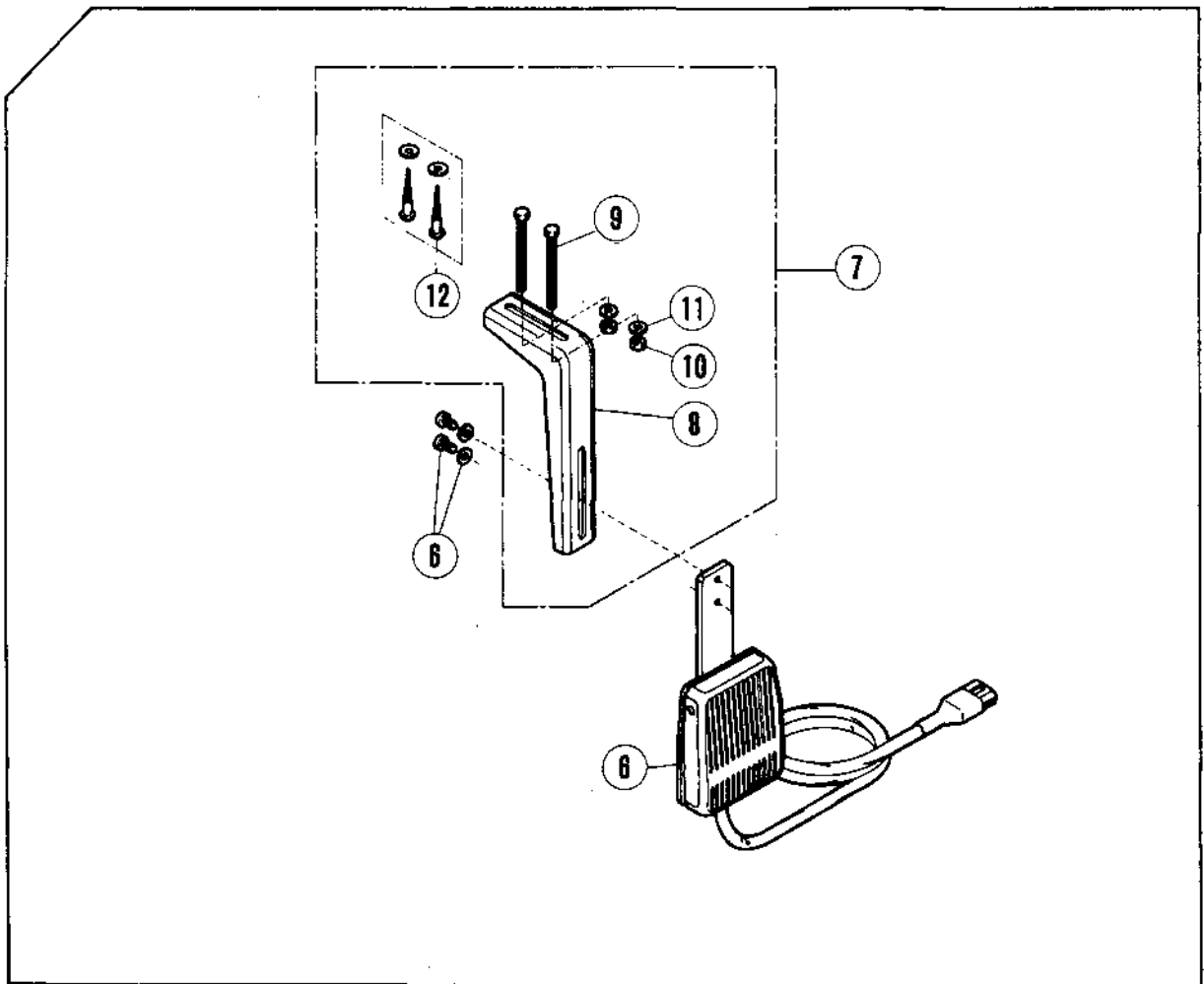
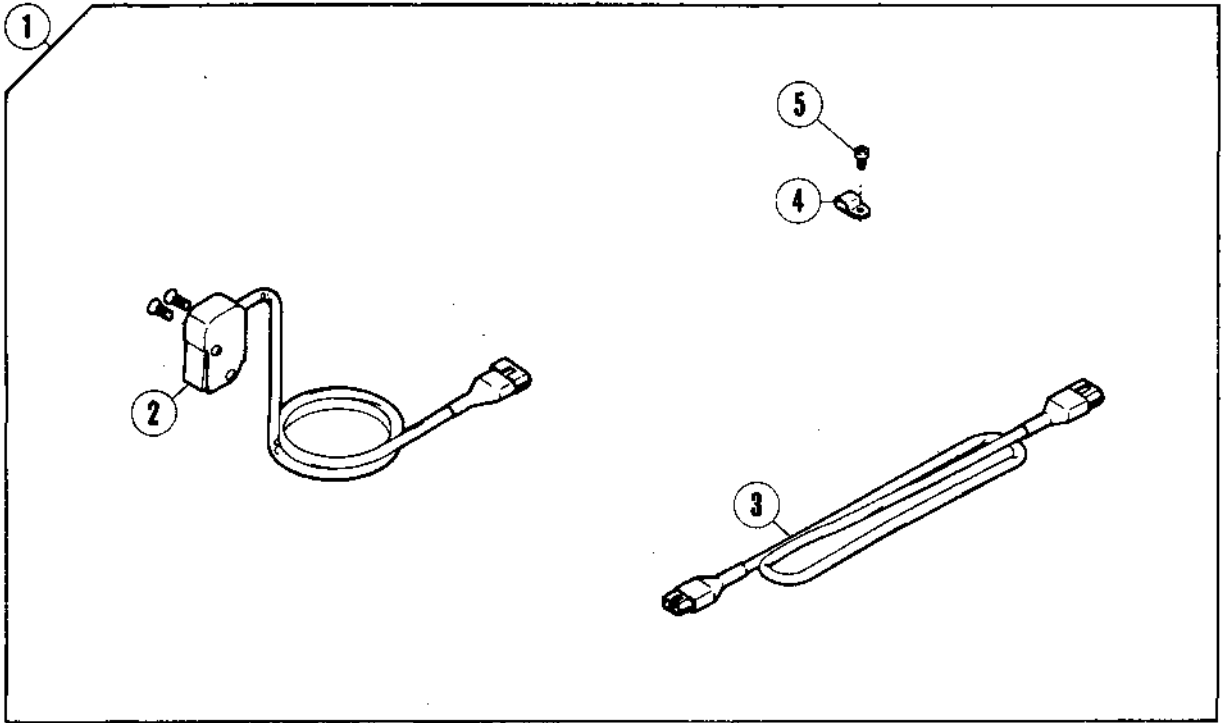

スイッチ(電気式TK装置用)

SWITCHES
(FOR SOLENOID OPERATED TK DEVICE)

REF. NO.	PART NO.	メイヨウ	NAME	QT.
1	303510	シユト*ウスイッチ(クミ)	PUSH BUTTON SWITCH ASSEMBLY	1
2	303511	シユト*ウスイッチ	PUSH SWITCH	1
3	742067	チユウケイコト*	EXTENSION CORD	1
4	748003	ナイロソクリツフ°	CLAMP	1
5	2905	ヒラネシ*/C5	SCREW	1
6	708004	ヒサ*スイッチ(クミ)	KNEE SWITCH ASSEMBLY	1
7	303010	フ*ラケツト(クミ)	BRACKET ASSEMBLY	1
8	197	フ*ラケツト	BRACKET	1
9	4300	口ツカクネシ*/M5	SCREW	2
10	4805	ナツト (M5)	NUT	2
11	204585	サ*カ*ネ	WASHER	2
12	4910	モクネシ*	SCREW	2

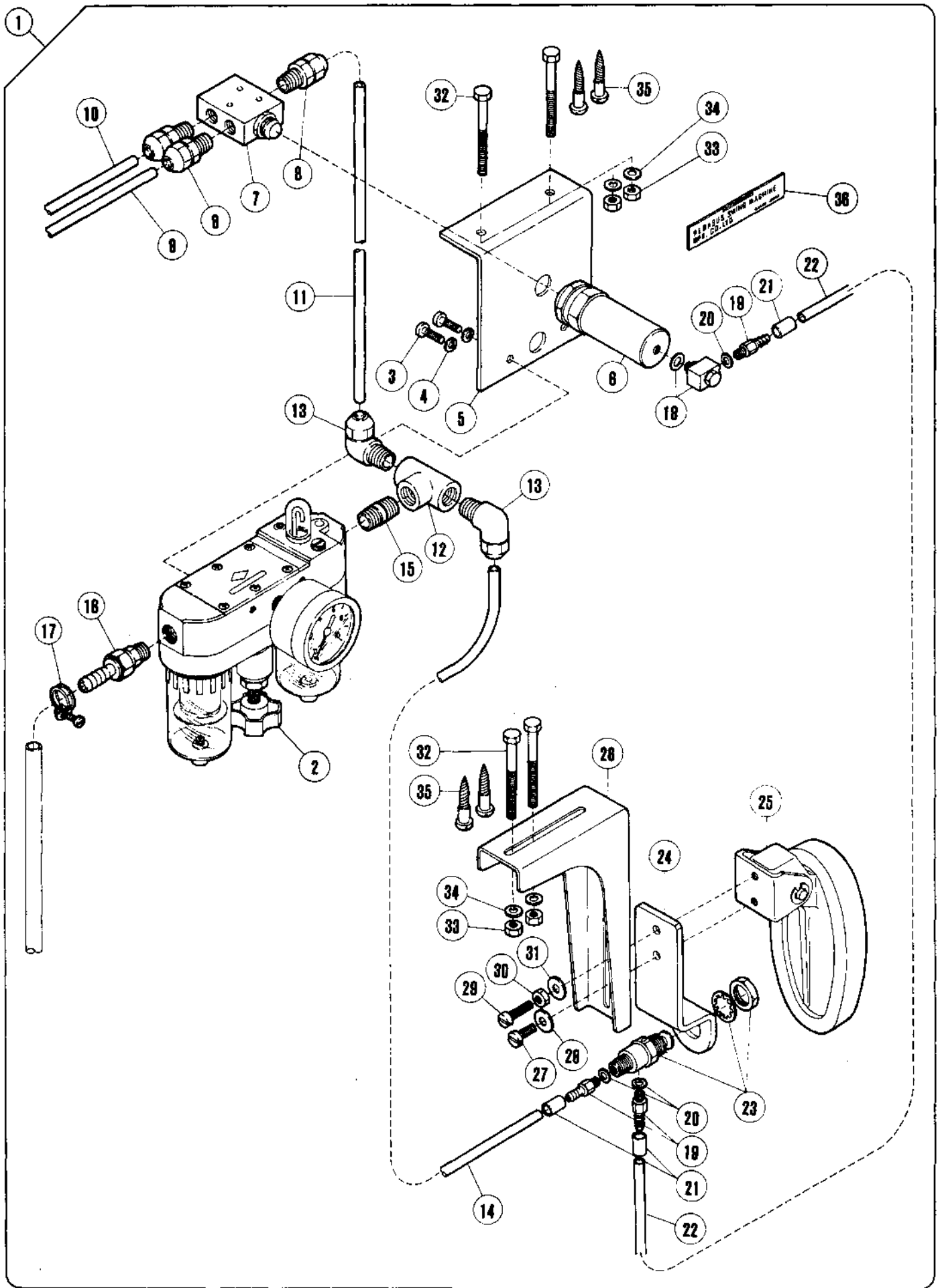

制御ユニット
(空気圧制御式TK装置用)

CONTROL UNIT
(FOR PNEUMATICALLY OPERATED TK DEVICE)

REF. PART NO.	NO.	メキシコ	NAME	QT.	
	1	605003	セイキョユニット	CONTROL UNIT	1
	2	595001	ルフトユニット	LUB-UNIT ASSEMBLY	1
	3	4012	トメネジ	SCREW	2
	4	300291	ハネサカネ	SPRING WASHER	2
	5	300215	ブラケット	BRACKET	1
	6	555001	アクチエータ	AIR ACTUATOR	1
	7	532004	エアバルブ	AIR VALVE	1
	8	601042	ツキテ	CONNECTOR	3
	9	600013	チューブ(4X6X130)	TUBE (4X6X130)	1
	10	600014	チューブ(4X6X120)	TUBE (4X6X120)	1
	11	600012	チューブ(4X6X80)	TUBE (4X6X80)	1
	12	601040	Tツキテ(1/4)	T JOINT	1
	13	601030	DMツキテ(6L-1/4)	DM CONNECTOR (6L-1/4)	2
	14	600016	チューブ(4X6X750)	TUBE (4X6X750)	1
	15	601038	ニツフル	BARREL NIPPLE	1
	16	601049	エアホースジョイント	JOINT	1
	17	608002	ワイヤーバンド	WIRE BAND	1
	18	601020	ユニオンサルエルボ	ELBOW	1
	19	601002	I ツキテ	JOINT	3
	20	201759	カスケツト	WASHER	3
	21	601043	スリーブ	SLEEVE	3
	22	600015	チューブ(4X6X830)	TUBE (4X6X830)	1
	23	531001	エアバルブ 3P	AIR VALVE	1
	24	300216	ブラケット	BRACKET	1
	25	300220	バルブ アクチエータ(クミ)	VALVE ACTUATOR ASSEMBLY	1
	26	197	ブラケット	BRACKET	1
	27	5118	ヒラネジ/C5	SCREW	1
	28	137142	サカネ	WASHER	1
	29	5183	ヒラネジ/C5	SCREW	1
	30	3044	ロツカクナツト/C5	NUT	1
	31	137142	サカネ	WASHER	1
	32	4300	ロツカクネジ/M5	SCREW	4
	33	4805	ナツト(M5)	NUT	4
	34	204585	サカネ	WASHER	4
	35	4910	モクネジ	SCREW	4
	36	202526	ネメイハン	NAME PLATE	1

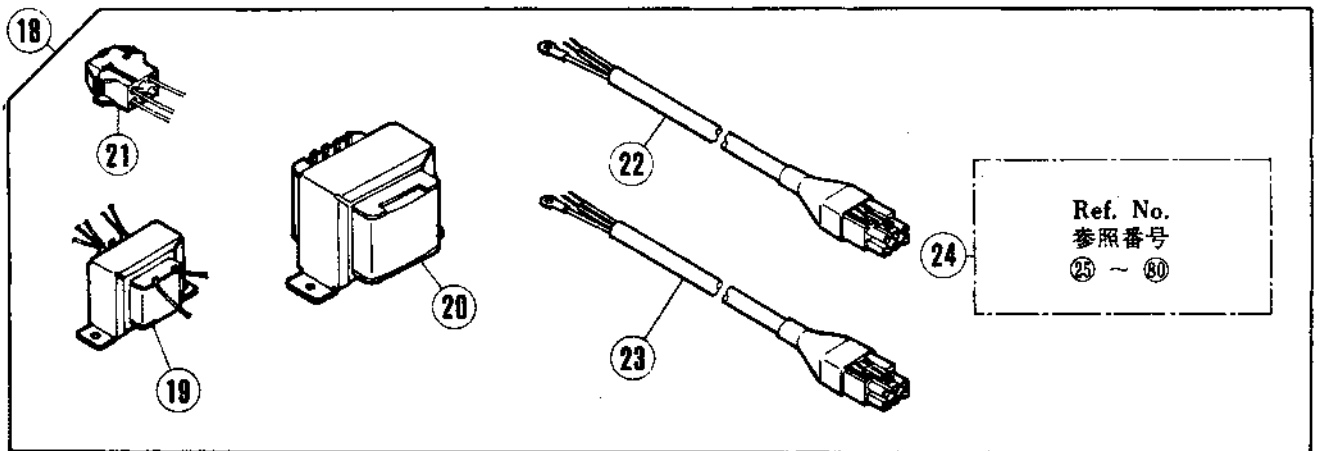
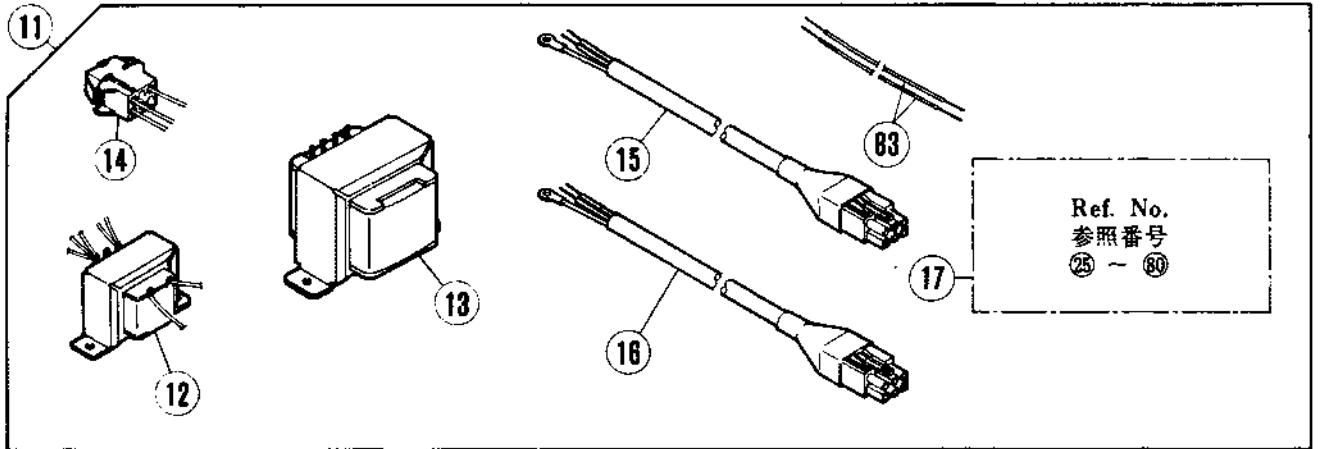
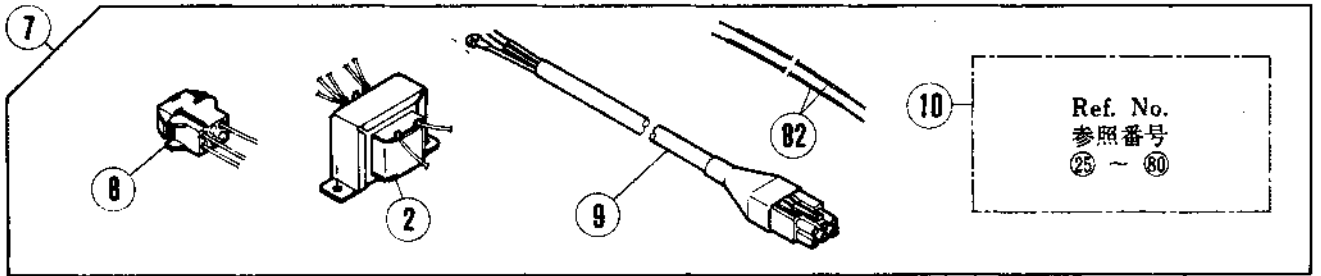
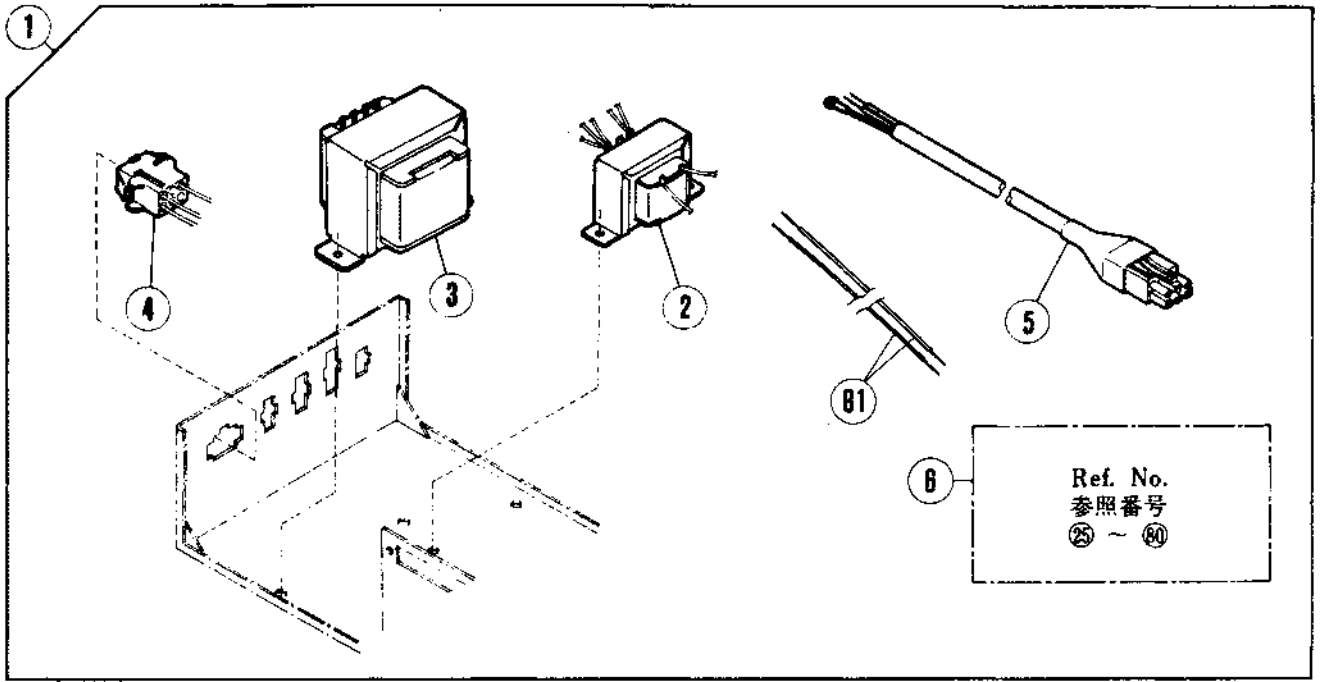

共通パーツ
COMMON PARTS

6 • 10 • 17 • 24

ATコントローラー(CPセンサ)(1)

AT CONTROLLER (CP SENSOR)(1)

REF. NO.	PART NO.	メイショウ	NAME	QT.
1	760081	ATコントローラー(100V)	AT CONTROLLER (100V)	1
2	791005	トランスGLT501	TRANSFORMER	1
3	790001	オートトランスAT01	AUTO TRANSFORMER	1
4	742085	テック*コンピュータケーブル	POWER INPUT CABLE	1
5	742076	テック*電源コード100V	POWER SOURCE CORD/100V	1
7	760082	ATコントローラー(200V)	AT CONTROLLER (200V)	1
8	742106	テック*コンピュータケーブル	POWER INPUT CABLE	1
9	742075	テック*ジャンクション	JUNCTION CORD/PUSH BUTTON	1
11	760083	ATコントローラー(220/240V)	AT CONTROLLER (220/240V)	1
12	791006	トランスGLT502	TRANSFORMER	1
13	790002	オートトランスAT02	AUTO TRANSFORMER	1
14	742086	テック*コンピュータケーブル	POWER INPUT CABLE	1
15	742077	テック*電源コード220V	POWER SOURCE CORD/220V	1
16	742078	テック*電源コード240V	POWER SOURCE CORD/240V	1
18	760084	ATコントローラー(380/415V)	AT CONTROLLER (380/415V)	1
19	791013	トランスGLT503	TRANSFORMER	1
20	790003	オートトランスAT03	AUTO TRANSFORMER	1
21	742107	テック*コンピュータケーブル	POWER INPUT CABLE (380V)	1
22	742087	テック*電源コード(380V)	POWER SOURCE CORD (380V)	1
23	742088	テック*電源コード(415V)	POWER SOURCE CORD (415V)	1
81	742117	ACワイヤリード	AC WIRING LEAD	1
82	742118	ACワイヤリード	AC WIRING LEAD	1
83	742119	ACワイヤリード	AC WIRING LEAD	1

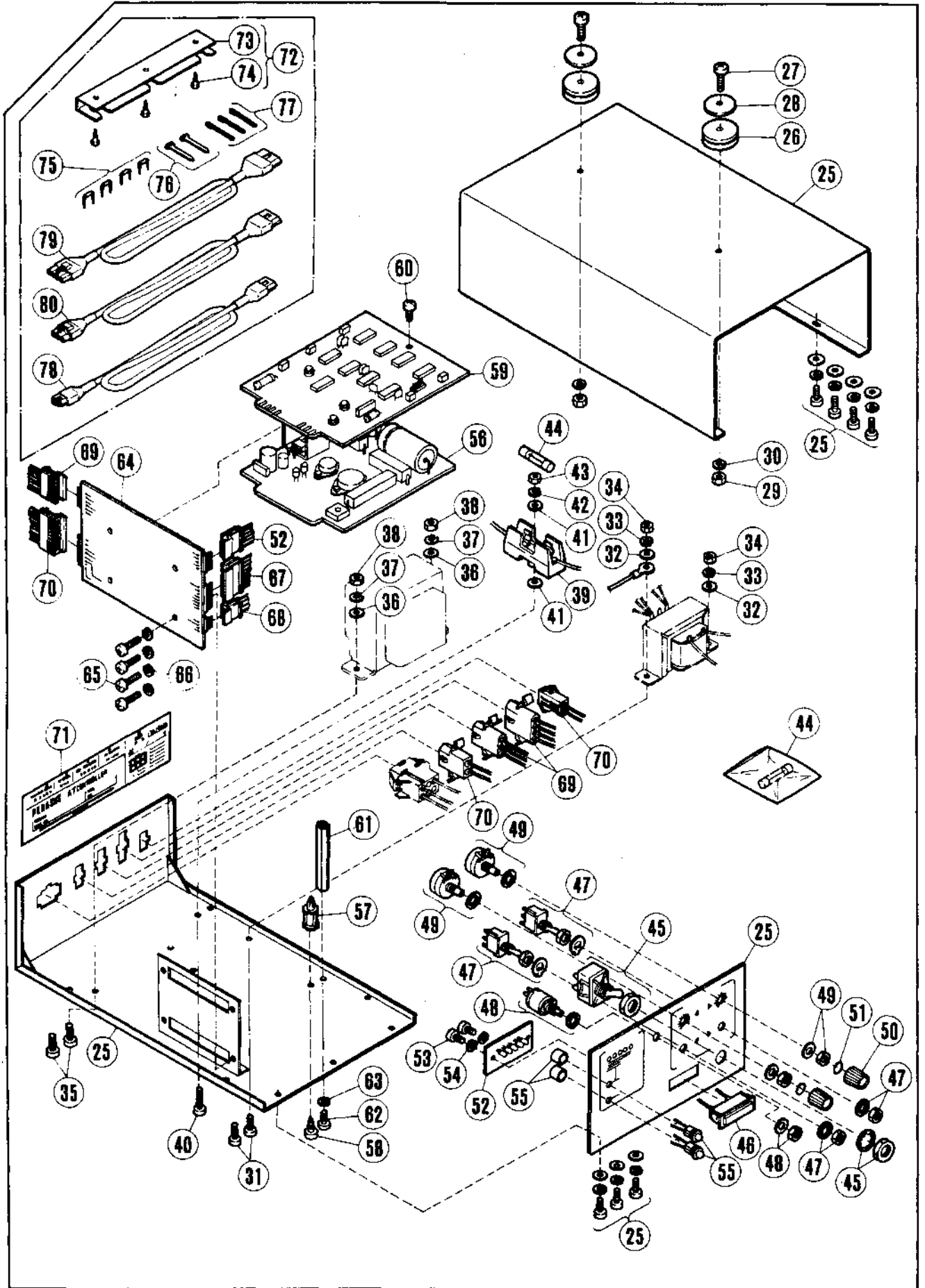

ATコントローラー(CPセンサ)(2)

AT CONTROLLER (CP SENSOR) (2)

REF. NO.	PART NO.	メイヨク	NAME	QT.
25	760077	ケース	CASE	1
26	202013	ヌノオサエゴム	FABRIC GUIDE RUBBER	2
27	4107	ヒラネシ/M4	SCREW	2
28	303026	ワッシャー	WASHER	2
29	4802	ナット (M4)	NUT	2
30	201252	ハネサワカネ	SPRING WASHER	2
31	4119	ヒラネシ	SCREW	2
32	303550	ワッシャー	WASHER	2
33	204586	ハネサワカネ	SPRING WASHER	2
34	4800	ロツカクナット/M3	NUT	2
35	4122	ヒラネシ	SCREW	2
36	303448	ワッシャー	WASHER	2
37	201252	ハネサワカネ	SPRING WASHER	2
38	4803	ナット (M4)	NUT	2
39	772002	ヒューズホルダー	FUSE HOLDER	1
40	4105	ヒラネシ	SCREW	1
41	303550	ワッシャー	WASHER	2
42	204586	ハネサワカネ	SPRING WASHER	1
43	4800	ロツカクナット/M3	NUT	1
44	771003	ヒューズ (1A)	FUSE/1A	2
45	701008	メインスイッチ	MAIN SWITCH	1
46	783001	ネオンランプ	NEON LAMP	1
47	701004	トグルスイッチ	TOGGLE SWITCH	2
48	850004	可変抵抗器	VARIABLE RESISTOR	1
49	850007	可変抵抗器	VARIABLE RESISTOR	2
50	750008	レギュレーター	REGULATOR	2
51	303865	Oリング (P5)	O RING	2
52	745039	インディケータ(クミ)	INDICATOR ASSEMBLY	1
53	4106	ヒラネシ/M3	SCREW	2
54	204586	ハネサワカネ	SPRING WASHER	2
55	785001	発光ダイオード	LIGHT EMITTING DIODE	2
56	745030	電源制御基板(クミ)	POWER CONTROL BOARD ASSEMBLY	1
57	748011	タップ支持	TAPPING SUPPORT	1
58	4118	ヒラネシ/M4	SCREW	1
59	745031	制御基板(クミ)	CONTROL BOARD ASSEMBLY	1
60	4100	ヒラネシ/M3	SCREW	1
61	303721	スペーサー	SPACER	1
62	4119	ヒラネシ	SCREW	1
63	204586	ハネサワカネ	SPRING WASHER	1
64	745032	マザーボード(クミ)	MOTHER BOARD	1
65	4104	ヒラネシ	SCREW	4
66	204586	ハネサワカネ	SPRING WASHER	4
67	742102	LEDボリュームケーブル	LED VOLUME CABLE	1
68	742103	スイッチケーブル/TK	SWITCH CABLE/TK	1
69	742104	ケーブル回転検出	CABLE/CP REVOLUTION DETECT	1
70	742105	ソレノイドケーブル(クミ)	SOLENOID CABLE ASSEMBLY	1
71	301327	表示板	INDICATION PLATE	1
72	303500	ブラケット(クミ)	BRACKET ASSEMBLY	1
73	303499	ブラケット	BRACKET	1
74	4911	ネジ	SCREW	3
75	748007	ステープル	STAPLE	4
76	748002	バンド	BAND	2
77	748004	バンド	BAND	3
78	742044	延長ケーブル/TK	EXTENSION CORD/TK	1
79	742094	延長ケーブル/CP	EXTENSION CORD/CP	1
80	742095	延長ケーブル/回転	EXTENSION CORD/REVOLUTION	1

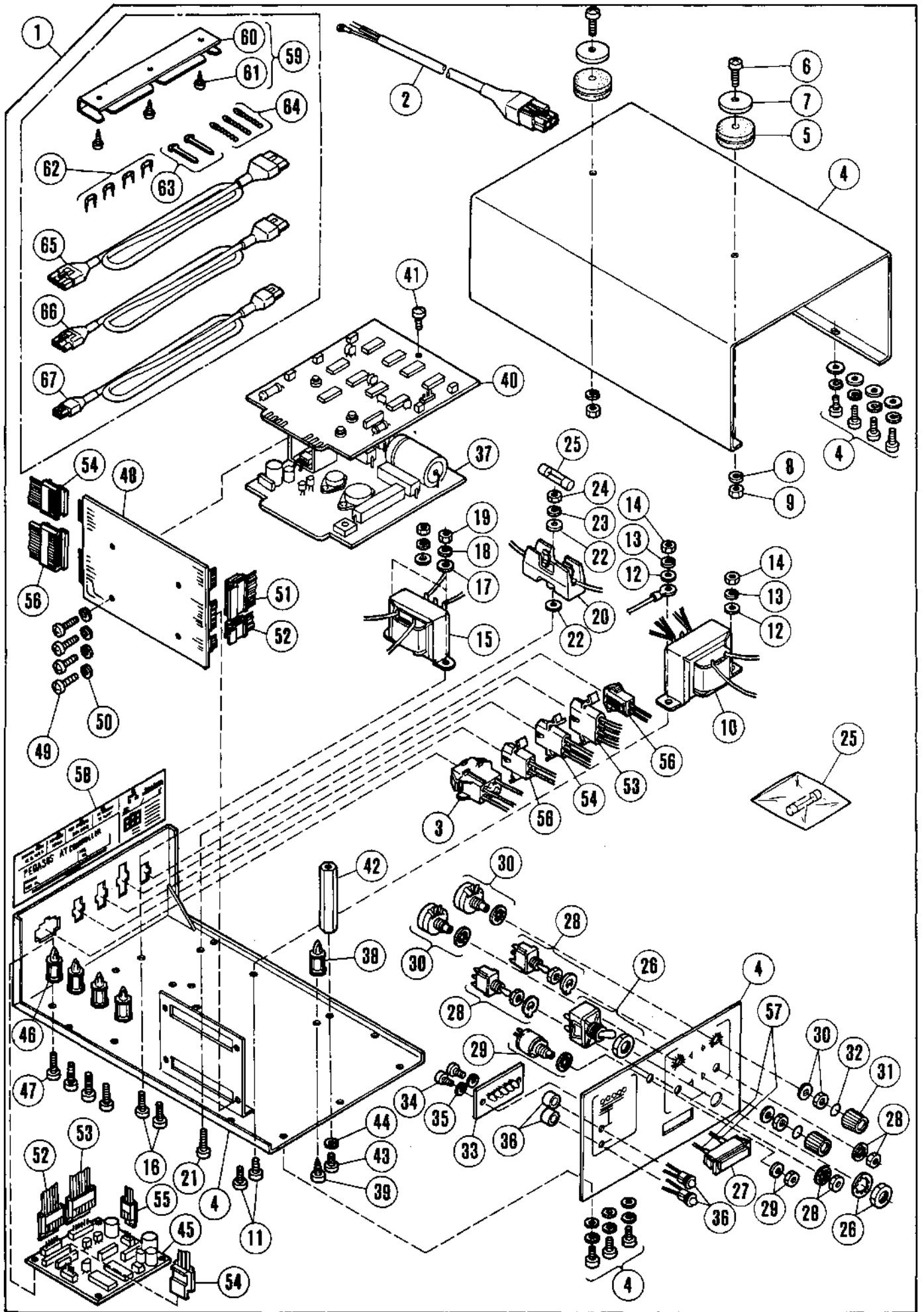

ATコントローラー(MPセンサ)

AT CONTROLLER (MP SENSOR)

REF. NO.	PART NO.	メイヨク	NAME	QT.
1	760132	ATコントローラー(200V)	AT CONTROLLER (200V)	1
2	742075	テングァンコート*(200V)	JUNCTION CORD/PUSH BUTTON	1
3	742106	テングァンコウリヨクゲーフ	POWER INPUT CABLE	1
4	760129	ケース	CASE	1
5	202013	ヌノオサエゴム	FABRIC GUIDE RUBBER	2
6	4107	ヒラネシ/M4	SCREW	2
7	303026	ワカネ	WASHER	2
8	201252	ハネサカネ	SPRING WASHER	2
9	4802	ナツト (M4)	NUT	2
10	791005	トランスGLT501	TRANSFORMER	1
11	4119	ヒラネシ	SCREW	2
12	303550	ワカネ	WASHER	2
13	204586	ハネサカネ	SPRING WASHER	2
14	4800	ロツカクナツト/M3	NUT	2
15	791008	トランスTK01	TRANSFORMER	1
16	4119	ヒラネシ	SCREW	2
17	303550	ワカネ	WASHER	2
18	204586	ハネサカネ	SPRING WASHER	2
19	4800	ロツカクナツト/M3	NUT	2
20	772002	ヒューズホルダー	FUSE HOLDER	1
21	4105	ヒラネシ	SCREW	1
22	303550	ワカネ	WASHER	2
23	204586	ハネサカネ	SPRING WASHER	1
24	4800	ロツカクナツト/M3	NUT	1
25	771003	ヒューズ(1A)	FUSE/1A	2
26	701008	テングァンスイッチ	MAIN SWITCH	1
27	783001	ネオンランプ	NEON LAMP	1
28	701004	トグルスイッチ	TOGGLE SWITCH	2
29	850004	カヘンテイコウキ	VARIABLE RESISTOR	1
30	850007	カヘンテイコウキ	VARIABLE RESISTOR	2
31	750008	ツマミ	REGULATOR	2
32	303865	オリンク(P5)	O RING	2
33	745056	インテイクター(クミ)	INDICATOR ASSEMBLY	1
34	4106	ヒラネシ/M3	SCREW	2
35	204586	ハネサカネ	SPRING WASHER	2
36	785001	ハツコウダイオード	LIGHT EMITTING DIODE	2
37	745030	テングァンキハシ(クミ)	POWER CONTROL BOARD ASSEMBLY	1
38	748011	タツヒンクサホート	TAPPING SUPPORT	1
39	4118	ヒラネシ/M4	SCREW	1
40	745031	セイキョキハシ(クミ)	CONTROL BOARD ASSEMBLY	1
41	4100	ヒラネシ/M3	SCREW	1
42	303721	キハシスパー	SPACER	1
43	4119	ヒラネシ	SCREW	1
44	204586	ハネサカネ	SPRING WASHER	1
45	745050	MPセンサキハシ(クミ)	MP SENSOR BOARD ASSEMBLY	1
46	748014	タツヒンクサホート	TAPPING SUPPORT	4
47	4118	ヒラネシ/M4	SCREW	4
48	745032A	マザーボード(クミ)	MOTHER BOARD ASSEMBLY	1
49	4104	ヒラネシ	SCREW	4
50	204586	ハネサカネ	SPRING WASHER	4
51	742187	コネクタコート(クミ)	CONNECTOR CORD ASSEMBLY	1
52	742103	スイッチケーブル/TK	SWITCH CABLE/TK	1
53	742183	コネクタコート(クミ)/MP	CONNECTOR CORD ASSEMBLY/MP	1
54	742184	コネクタコート(クミ)/カイテン	CONNECTOR CORD ASSEMBLY/REV.	1
55	742185	コネクタコート(クミ)	CONNECTOR CORD ASSEMBLY	1
56	742105	ソレノイドケーブル(クミ)	SOLENOID CABLE ASSEMBLY	1
57	742186	ACワイヤリード	AC WIRING LEAD	1
58	301886	コネクタヒョウシキハシ	CONNECTOR INDICATION PLATE	1
59	303500	ブラケット(クミ)	BRACKET ASSEMBLY	1
60	303499	ブラケット	BRACKET	1
61	4911	モクネシ	SCREW	3
62	748007	ステイプル	STAPLE	4
63	748002	ソクセンバンド	BAND	2
64	748004	ヒューズバンド	BAND	3
65	742044	テングァンコート/TK	EXTENSION CORD/TK	1
66	742188	テングァンコート/MP	JUNCTION CORD/MP	1
67	742095	テングァンコート/カイテン	EXTENSION CORD/REVOLUTION	1

1

E32・E52

CP センサー
CP SENSOR

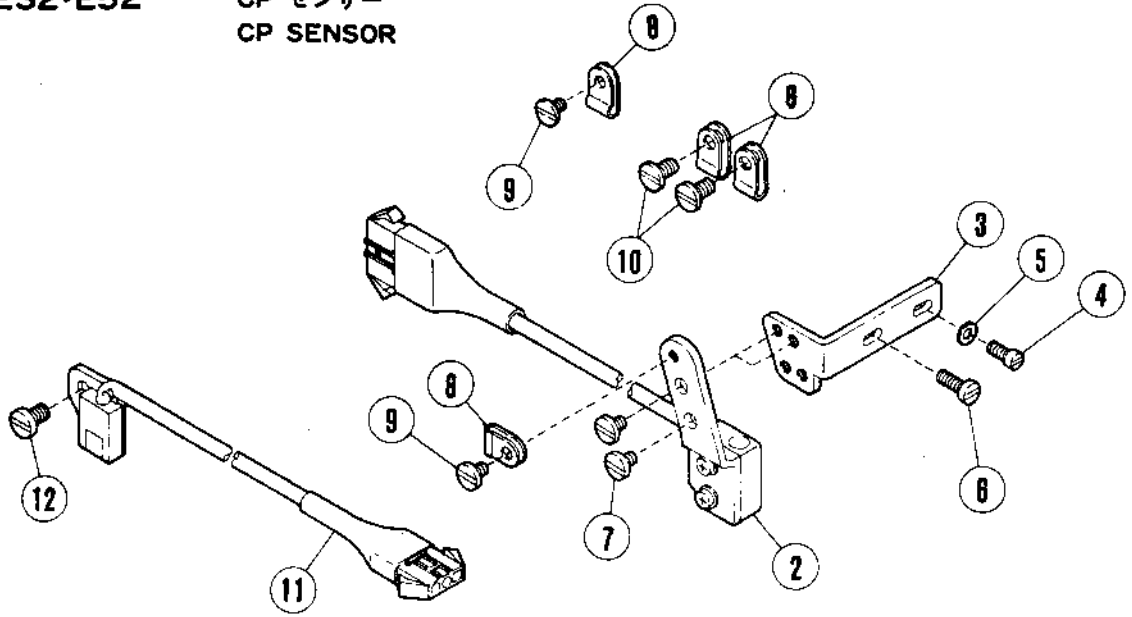

13

E32・E52
ETS32・ETS52

MP センサー
MP SENSOR

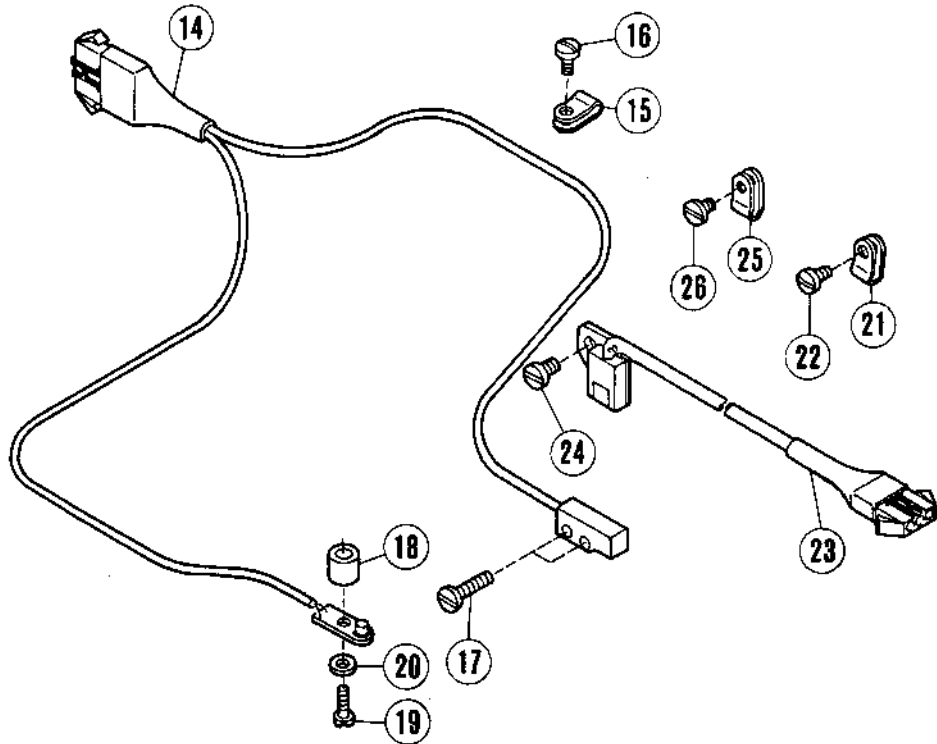

センサセット(1)

SENSOR SET(1)

REF. NO.	PART NO.	メキシコ	NAME	QT.
1	301599	センサセット	SENSOR SET	1
2	712006	CPセンサ	CP SENSOR	1
3	301597	ブラケット	BRACKET	1
4	2924	ヒラネシ/C4	SCREW	1
5	200821	ワッシャ	WASHER	1
6	1175-3	ヒラネシ/C4	SCREW	1
7	2905-HC	ヒラネシ/C5	SCREW	2
8	748005	ナイロンクリップ(2A)	CLAMP	4
9	2905-HC	ヒラネシ/C5	SCREW	2
10	4009-1	ヒラネシ/C5	SCREW	2
11	716007	カイトンゲンユツキ	REVOLUTION DETECTOR	1
12	4009-1	ヒラネシ/C5	SCREW	1
13	301916	センサセット	SENSOR SET	1
14	712008	MPセンサ	MP SENSOR	1
15	748005	ナイロンクリップ(2A)	CLAMP	1
16	4009-1	ヒラネシ/C5	SCREW	1
17	5010	ヒラネシ/C4	SCREW	2
18	301272	スリーブ	SLEEVE	1
19	2918	ヒラネシ/C3	SCREW	1
20	301895	ワッシャ	WASHER	1
21	748005	ナイロンクリップ(2A)	CLAMP	1
22	4009-1	ヒラネシ/C5	SCREW	1
23	716007	カイトンゲンユツキ	REVOLUTION DETECTOR	1
24	4009-1	ヒラネシ/C5	SCREW	1
25	748006	ナイロンクリップ(3A)	CLAMP	1
26	5113	ヒラネシ/C5	SCREW	1

CPセンサー

CP SENSOR

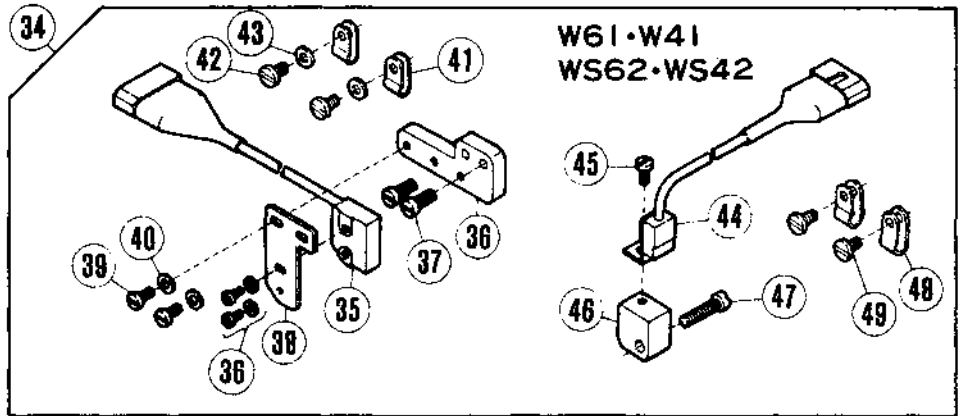
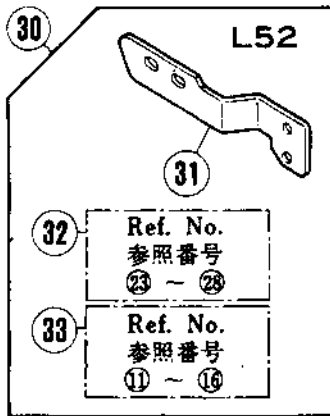
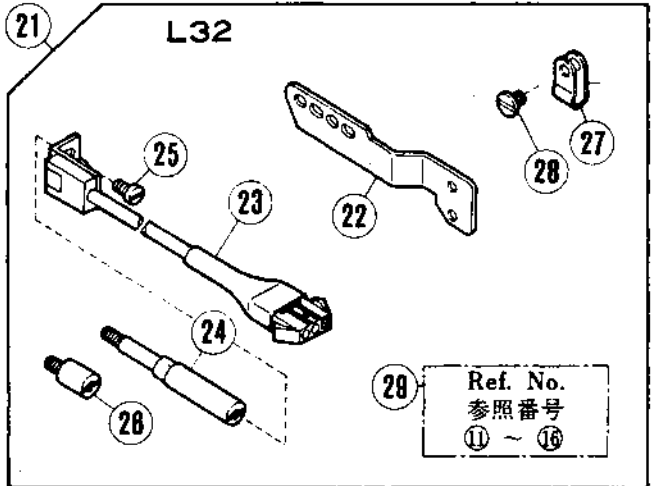
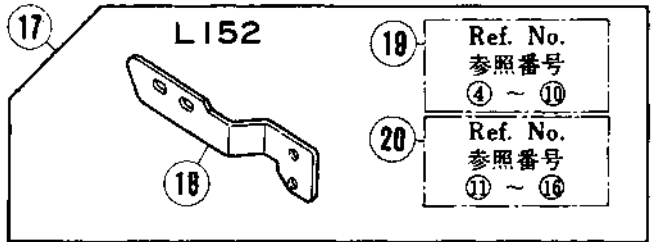
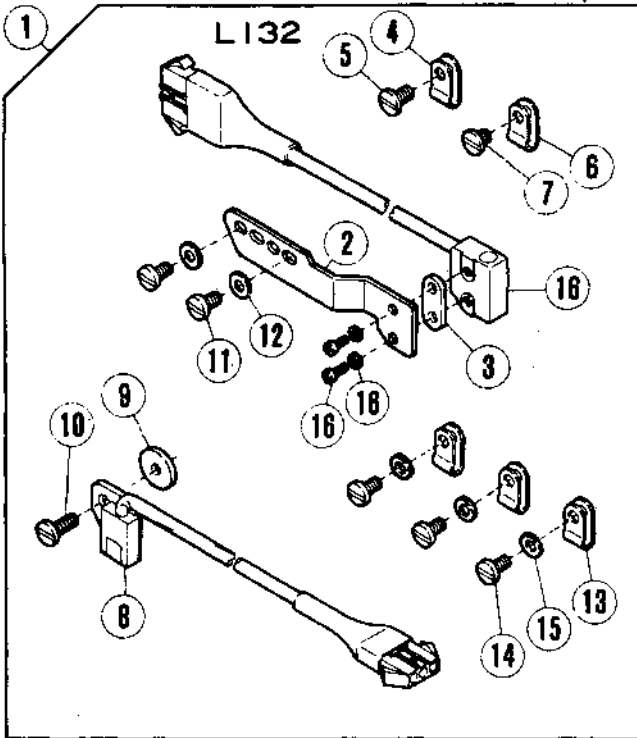

共通パーツ

COMMON PARTS

⑱・⑳・㉑・㉒・㉓

センサセット (2)

SENSOR SET (2)

REF. NO.	PART NO.	メイショウ	NAME	QT.
1	303783	センサ (セツト)	SENSOR SET	1
2	303677	ブラケット	BRACKET	1
3	301183	スペーサー	SPACER	1
4	748005	ナイロン クリツワ° (2A)	CLAMP	1
5	4009-1	ヒラネシ°/C5	SCREW	1
6	748005	ナイロン クリツワ° (2A)	CLAMP	1
7	2905	ヒラネシ°/C5	SCREW	1
8	716007	カイテンケツシユツキ	REVOLUTION DETECTOR	1
9	208245	サ°カ°ネ	WASHER	1
10	5345	ヒラネシ°/C5	SCREW	1
11	1216	ヒラネシ°	SCREW	2
12	303448	サ°カ°ネ	WASHER	2
13	748005	ナイロン クリツワ° (2A)	CLAMP	3
14	1202	ヒラネシ°	SCREW	3
15	303448	サ°カ°ネ	WASHER	3
16	712003	CPセンサ	CP SENSOR	1
17	303782	センサ (セツト)	SENSOR SET	1
18	303678	ブラケット	BRACKET	1
21	303823	センサ (セツト)	SENSOR SET	1
22	303677	ブラケット	BRACKET	1
23	716008	カイテンケツシユツキ	REVOLUTION DETECTOR	1
24	303337	トリツケシ°ク (チヨウ)	STUD (LONG)	1
25	5328	ヒラネシ°/C4	SCREW	1
26	303353	トリツケシ°ク (タツ)	STUD (SHORT)	1
27	748006	ナイロン クリツワ° (3A)	CLAMP	1
28	2905	ヒラネシ°/C5	SCREW	1
30	303822	センサ (セツト)	SENSOR SET	1
31	303678	ブラケット	BRACKET	1
34	306612	センサセット	SENSOR SET	1
35	712001	CP センサ	CP SENSOR	1
36	306257	ブラケット (ウエ)	BRACKET (UPPER)	1
37	2902	ヒラネシ°/C5	SCREW	2
38	306258	ブラケット (シタ)	BRACKET (LOWER)	1
39	1202	ヒラネシ°	SCREW	2
40	303448	サ°カ°ネ	WASHER	2
41	748005	ナイロン クリツワ° (2A)	CLAMP	2
42	1202	ヒラネシ°	SCREW	2
43	303448	サ°カ°ネ	WASHER	2
44	716002	カイテン ケツシユツキ	REVOLUTION DETECTOR	1
45	5328	ヒラネシ°/C4	SCREW	1
46	306262	ブラケット	BRACKET	1
47	5095	ヒラネシ°/C5	SCREW	1
48	748006	ナイロン クリツワ° (3A)	CLAMP	2
49	4009-1	ヒラネシ°/C5	SCREW	2

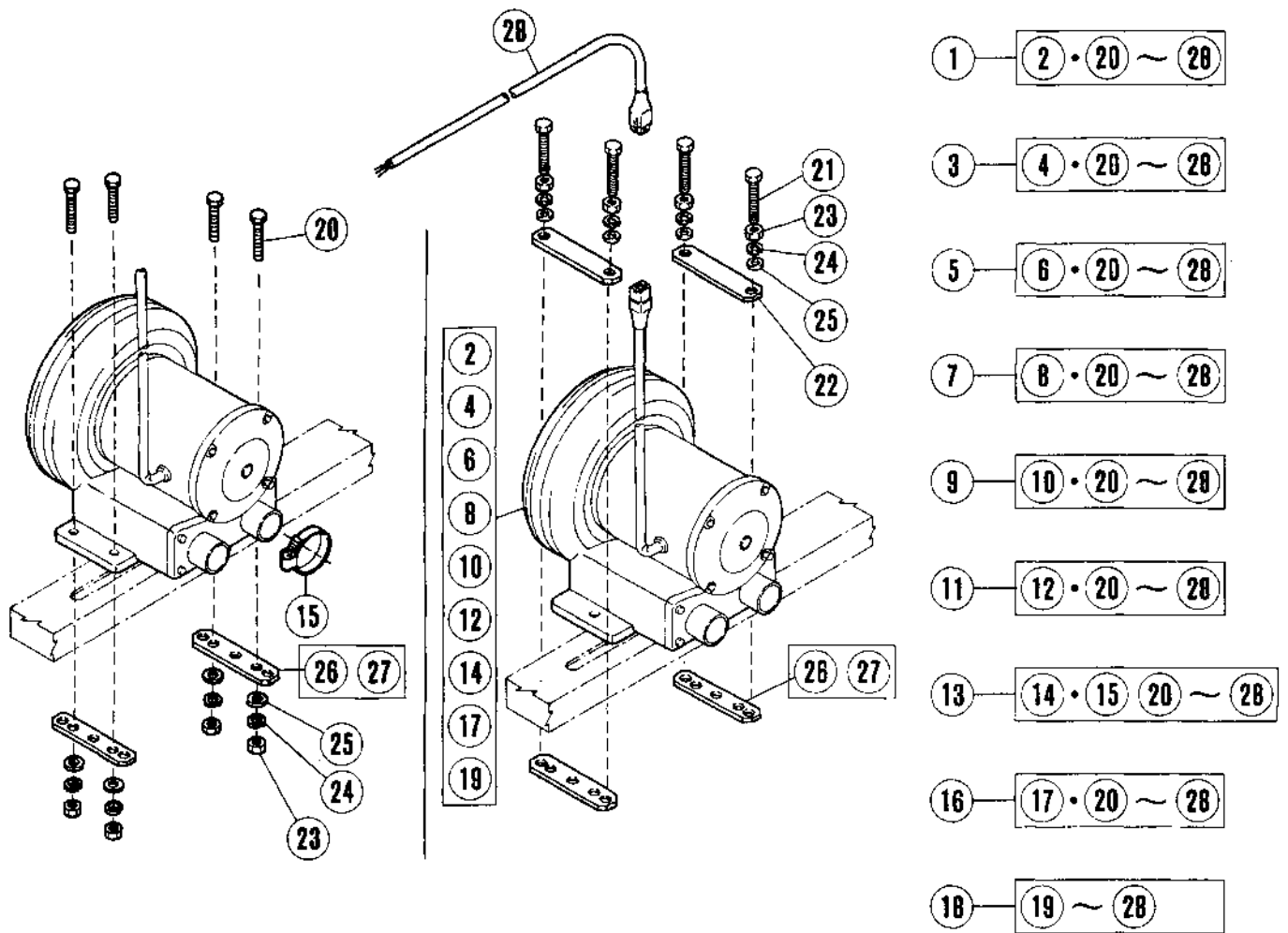

金脚の形式 STAND TYPE	ブロワ装置の部番 PART NUMBER OF BLOWER	仕様 SPECIFICATIONS			使用数 QT.							
		相数 PHASE	電圧 VOLTS	周波数 Hz	20	21	22	23	24	25	26	27
H 形 H TYPE	500005	1	100V	60Hz	2	—	—	2	2	2	2	—
	500006	3	200V	60Hz	2	—	—	2	2	2	2	—
	500011	3	220V	60Hz	2	—	—	2	2	2	2	—
	500007	1	100V	50Hz	4	—	—	4	4	4	2	—
	500008	3	200V	50Hz	4	—	—	4	4	4	2	—
	500009	1	220V	50Hz	4	—	—	4	4	4	2	—
	500013	3	200V	50Hz	4	—	—	4	4	4	—	2
	500015	3	380V	50Hz	4	—	—	4	4	4	2	—
	500017	1	240V	50Hz	4	—	—	4	4	4	2	—
Z 形 Z TYPE	500005	1	100V	60Hz	—	4	2	4	4	4	2	—
	500006	3	200V	60Hz	—	4	2	4	4	4	2	—
	500011	3	220V	60Hz	—	4	2	4	4	4	2	—
	500007	1	100V	50Hz	—	4	—	4	4	4	2	—
	500008	3	200V	50Hz	—	4	—	4	4	4	2	—
	500009	1	220V	50Hz	—	4	—	4	4	4	2	—
	500013	3	200V	50Hz	—	4	—	4	4	4	2	2
	500015	3	380V	50Hz	—	4	—	4	4	4	2	—
	500017	1	240V	50Hz	—	4	—	4	4	4	2	—

ブロワ装置

BLOWER DEVICE

REF. NO.	PART NO.	メイヨウ	NAME	QT.
1	500005	ブロワソウチ/1B	BLOWER ASSEMBLY/1B	1
2	500001	ブロワ/1B	BLOWER/1B	1
3	500006	ブロワソウチ/2B	BLOWER ASSEMBLY/2B	1
4	500002	ブロワ	BLOWER	1
5	500011	ブロワソウチ/3B	BLOWER ASSEMBLY/3B	1
6	500012	ブロワ	BLOWER	1
7	500007	ブロワソウチ/1A	BLOWER ASSEMBLY/1A	1
8	500003	ブロワ	BLOWER	1
9	500008	ブロワソウチ/2A	BLOWER ASSEMBLY/2A	1
10	500004	ブロワ	BLOWER	1
11	500009	ブロワソウチ/7A	BLOWER ASSEMBLY/7A	1
12	500010	ブロワ	BLOWER	1
13	500013	ブロワソウチ	BLOWER ASSEMBLY	1
14	500014	ブロワ	BLOWER	1
15	608001	ホースバンド	HOSE BAND	1
16	500015	ブロワソウチ/5A	BLOWER ASSEMBLY/5A	1
17	500016	ブロワ	BLOWER	1
18	500017	ブロワソウチ/8A	BLOWER ASSEMBLY/8A	1
19	500018	ブロワ	BLOWER	1
20	4328	6カクボルト	BOLT	※
21	4312	6カクボルト	BOLT	※
22	303846	スペーサー	SPACER	※
23	4808	ワザカクナツト	NUT	※
24	300294	ハネサカネ	SPRING WASHER	※
25	300172	サカネ	WASHER	※
26	302198	ブラケット	BRACKET	※
27	303997	ブラケット	BRACKET	※
28	742099	チユウガイコード	EXTENSION CORD	1

50頁参照
See page 50

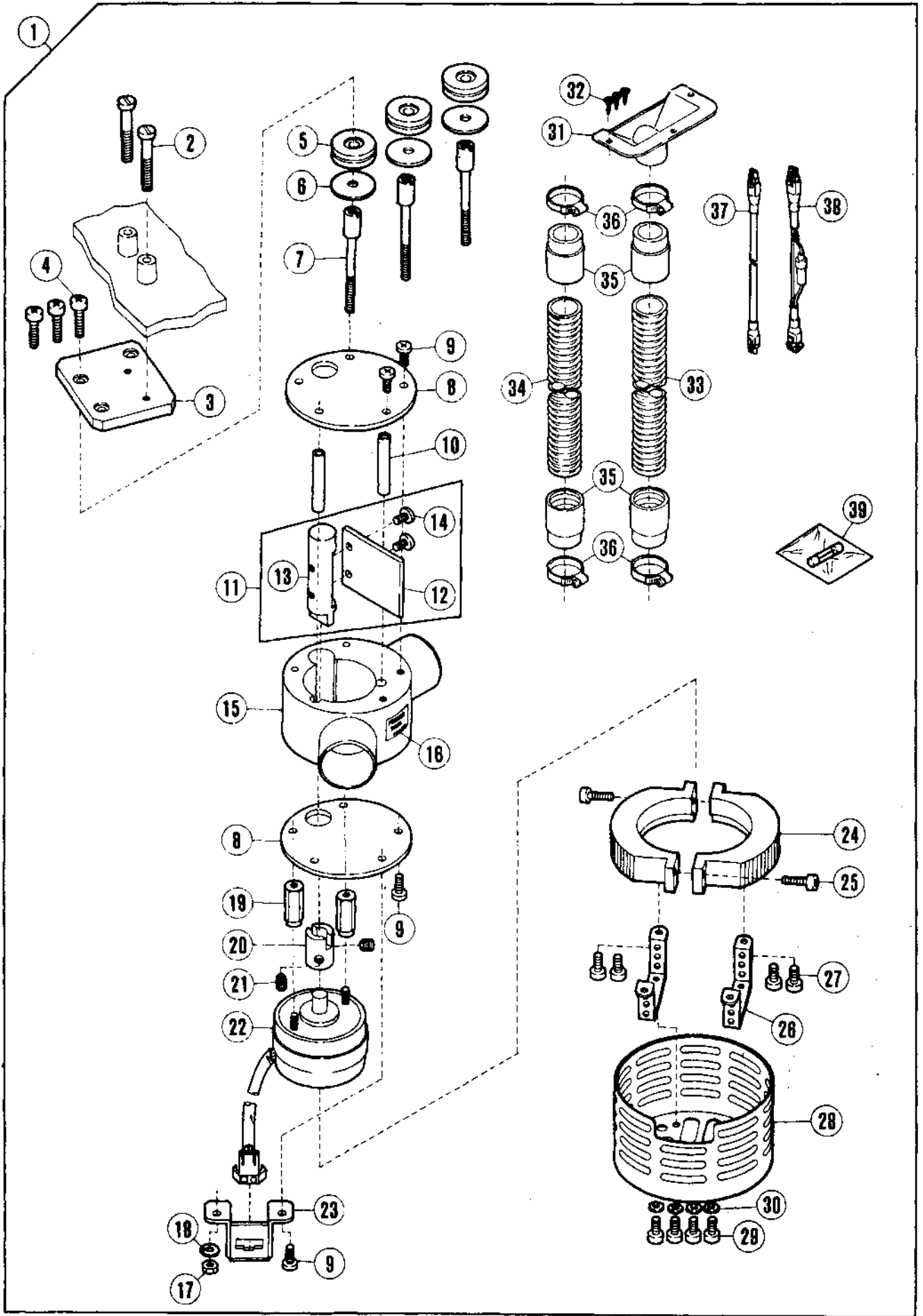

ダストドラム(1)

DUST DRUM(1)

REF. NO.	PART NO.	メイヨウ	NAME	QT.
1	303713	キリカエハツ(クミ)	SWITCHING VALVE ASSEMBLY	1
2	4016	ヒラネシ	SCREW	2
3	304031	ハース	BASE	1
4	4123	ヒラネシ	SCREW	3
5	202013	ヌノオサイゴム	FABRIC GUIDE RUBBER	3
6	192087	サカネ	WASHER	3
7	5528	スリーフ ホルト	BOLT	3
8	303744	ケーシツク ㊦	CASING CAP	2
9	4109	ヒラネシ	SCREW	4
10	303743	ハツサ	POST	2
11	303824	ハツ (クミ)	VALVE ASSEMBLY	1
12	303741	ハツ	VALVE	1
13	303742	シツク	SHAFT	1
14	4009-1	ヒラネシ / C5	SCREW	2
15	303738	ケーシツク	CASING	1
16	303858	メイバン	NAME PLATE	1
17	4803	ナツト (M4)	NUT	1
18	201252	ハネサカネ	CLOTH GUIDE	1
19	5529	6カク ナツト	NUT	2
20	303745	シヨイント	JOINT	1
21	4514	トメネシ	SCREW	2
22	811024	ソレノイド	SOLENOID	1
23	303746	ブラケット	BRACKET	1
24	304028	ホウネツリツク	HEAT RADIATING RING	2
25	4114	ヒラネシ / M4	SCREW	2
26	304029	ブラケット	BRACKET	2
27	4110	ヒラネシ / M4	SCREW	4
28	304030	アセツカシ	SAFETY COVER	1
29	4100	ヒラネシ / M3	SCREW	4
30	200183	サカネ	THRUST WASHER	4
31	303821	キリクスウケ	WASTE CHUTE TOP	1
32	4904	サラネシ	SCREW	3
33	600051	ホース (短)	TUBE (SHORT)	1
34	600050	ホース (長)	TUBE (LONG)	1
35	601046	ゴムカウス	RUBBER CUFF	4
36	608000	ホース ハツト	BAND	4
37	742100	チユウケイコト	EXTENSION CORD	1
38	742148	ヒユースコト	FUSE CORD	1
39	771005	ヒユース	FUSE	1

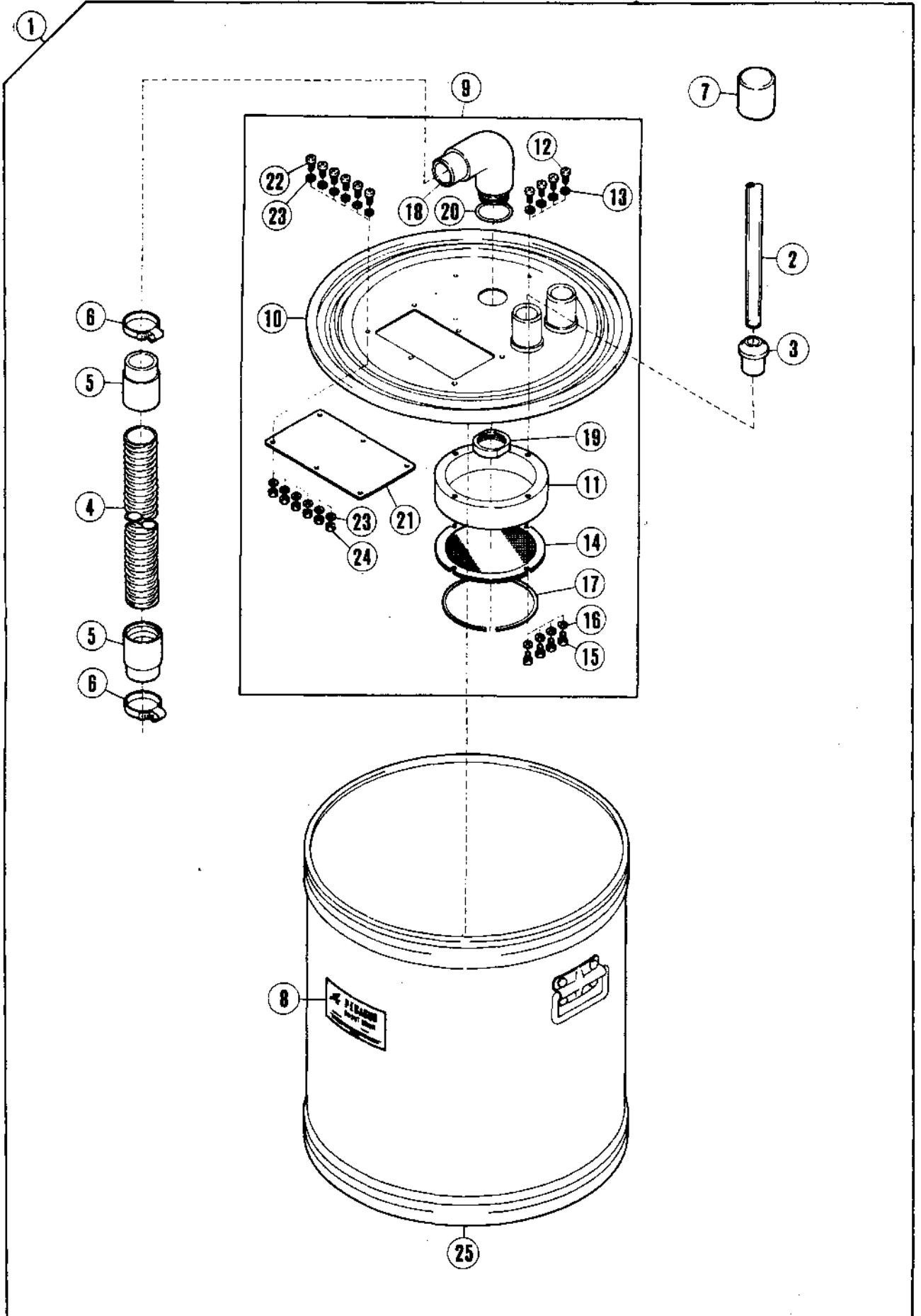

ダストドラム(2)

DUST DRUM(2)

REF. NO.	PART NO.	メイヨウ	NAME	QT.
1	303747	ダストドラム(クミ)	DUST DRUM ASSEMBLY	1
2	600006A	スイコムホース	SUCTION TUBE	1
3	601003	ツキテ(シヨウ)	CONNECTOR (SMALL)	1
4	600050	ホース(チヨウ)	TUBE (LONG)	1
5	601046	ゴムカウス	RUBBER CUFF	2
6	608000	ホースバンド	BAND	2
7	303847	キャップ	CAP	1
8	303750	メイプレート	NAME PLATE	1
9	303751	フタ(クミ)	COVER ASSEMBLY	1
10	303752	フタ	COVER	1
11	303813	ブラケット	BRACKET	1
12	4109	ヒラネシ	SCREW	4
13	303448	ワッシャー	WASHER	4
14	303814	フィルター	FILTER	1
15	4109	ヒラネシ	SCREW	4
16	200098	ワッシャー	WASHER	4
17	303815	リング	RING	1
18	303816	エルボ(クミ)	ELBOW ASSEMBLY	1
19	5527	ナット	NUT	1
20	206079	Oリング	O RING	1
21	303825	窓	WINDOW	1
22	4109	ヒラネシ	SCREW	6
23	303448	ワッシャー	WASHER	12
24	4802	ナット(M4)	NUT	6
25	303748	ファイバードラム	FIBER DRUM	1

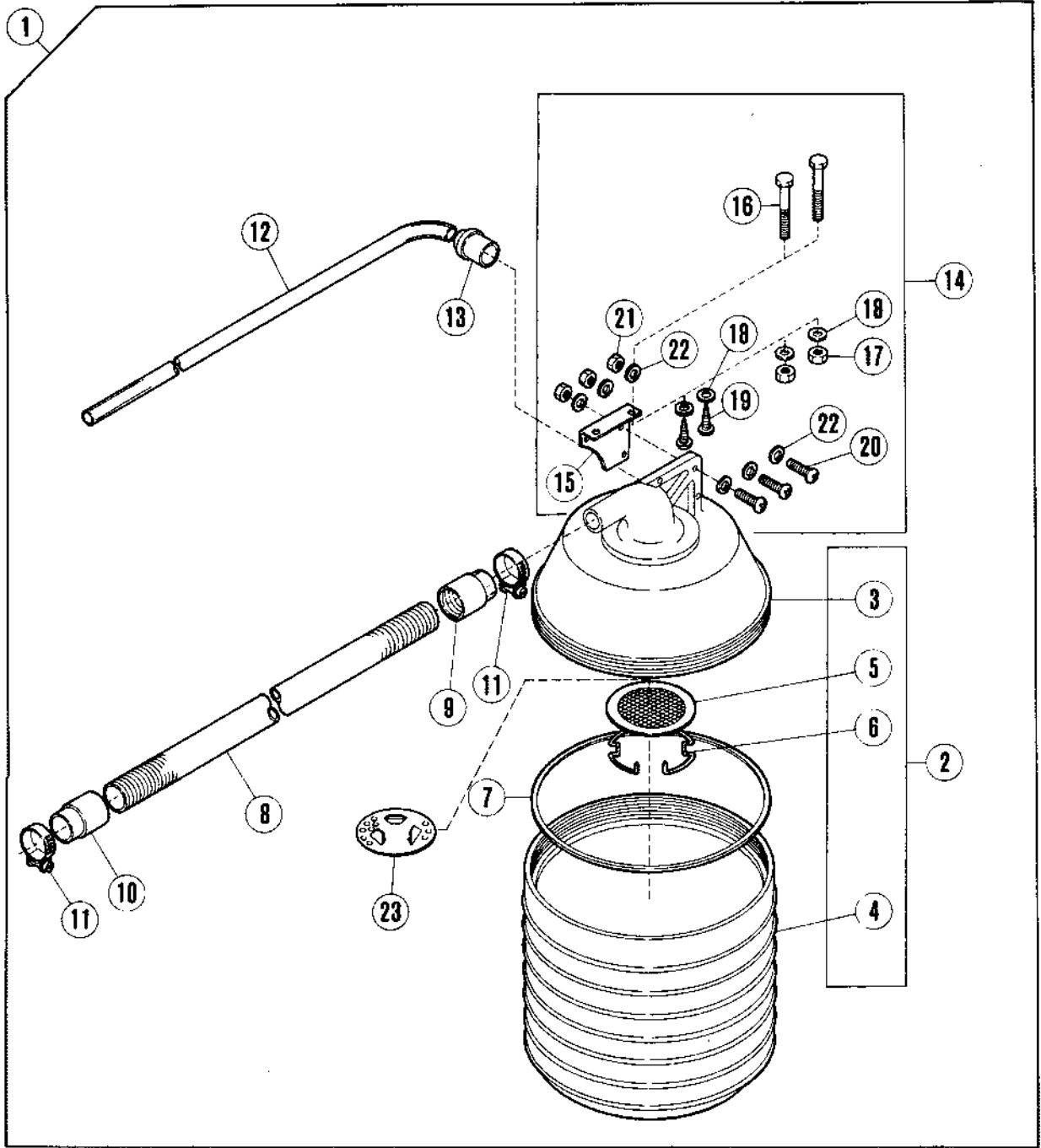

ブロウ用リントコレクター

WASTE RECEPTACLE
(FOR BLOWER DEVICE)

REF. NO.	PART NO.	メイヨウ	NAME	QT.
1	300305	リントコレクター	WASTE RECEPTACLE	1
2	300104A	リントコレクター(クミ)	WASTE RECEPTACLE COMPLETE	1
3	300105	リントコレクター(ウエ)	WASTE RECEPTACLE CAP	1
4	300106	リントコレクター(シタ)	WASTE RECEPTACLE	1
5	300107A	フィルター	AIR FILTER	1
6	300108	トメワ	RING	1
7	300257	ハ°ツキフ	GASKET	1
8	600050	ホース (チヨウ)	TUBE (LONG)	1
9	601047	ゴ°ムカウス	RUBBER CUFF	1
10	601046	ゴ°ムカウス	RUBBER CUFF	1
11	608000	ホース ハ°ット°	BAND	2
12	600006A	スイコミホース	SUCTION TUBE	1
13	601003	ツキ°テ(シヨウ)	CONNECTOR (SMALL)	1
14	300110	フ°ラケツト(B)クミ	BRACKET COMPLETE	1
15	300109	フ°ラケツト(B)	BRACKET	1
16	4300	ロツカクネシ°/M5	SCREW	2
17	4805	ナツト (M5)	NUT	2
18	204585	サ°カ°ネ	WASHER	2
19	4910	モクネシ°	SCREW	2
20	4113	ヒラネシ°	SCREW	3
21	4803	ナツト (M4)	NUT	3
22	303448	サ°カ°ネ	WASHER	6
23	300365	フィルターウケ	FILTER SUPPORT	1

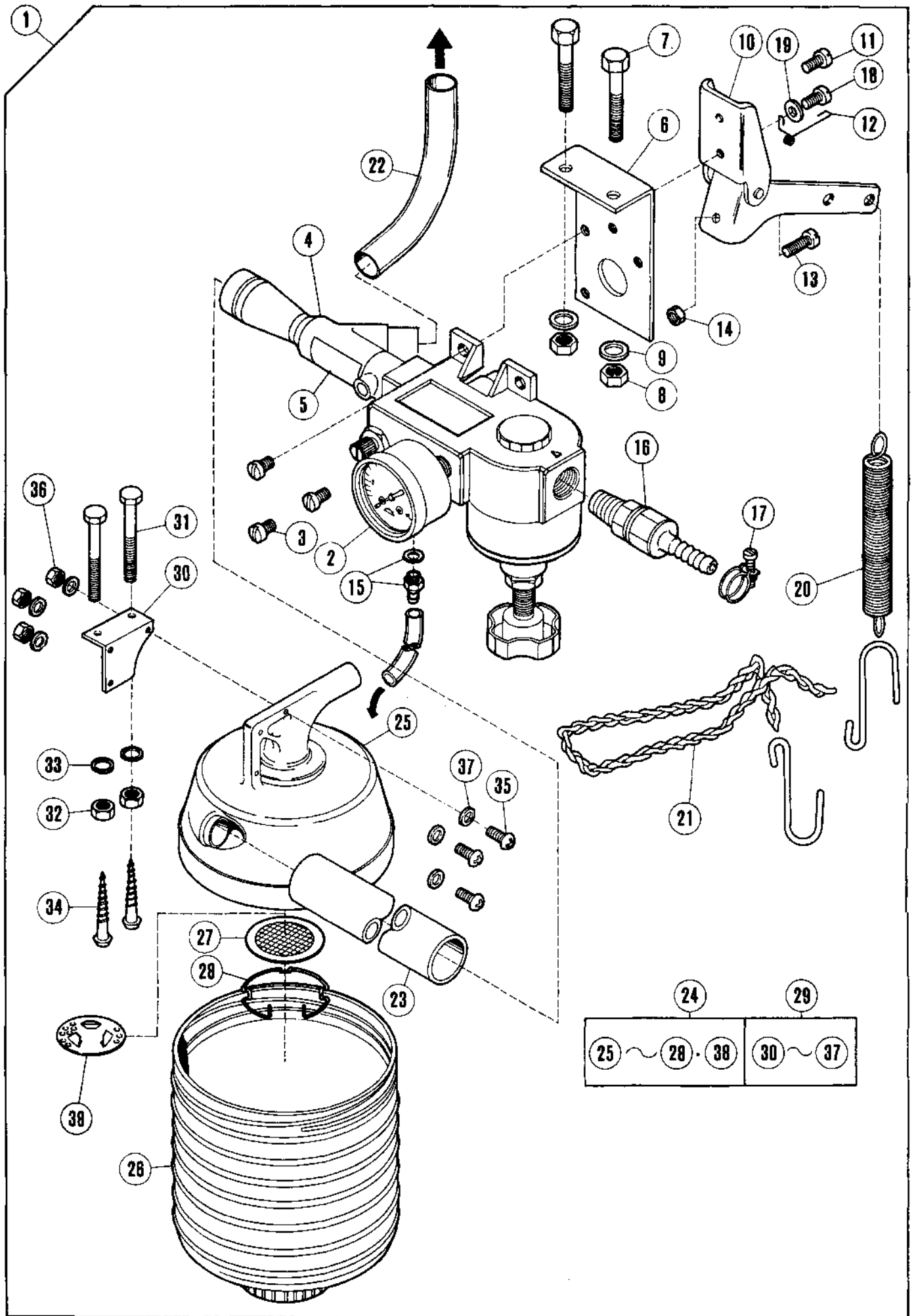

ベンチュリー装置

VENTURI DEVICE

REF. NO.	PART NO.	メイショウ	NAME	QT.
1	300207	VSA-200 ベンチュリーソウチ	VSA-200 VENTURI PARTS COM	1
2	300208	トクシユケ*ンアツヘ*ン(クミ)	AIR REGULATOR UNIT	1
3	4009-1	ヒラネシ*/C5	SCREW	3
4	300033	ベンチュリー	VENTURI COMPLETE	1
5	300318	メイハシ	NAME PLATE	1
6	300037	フ*ラケツト(A)	AIR VALVE BRACKET	1
7	4301	ロツカクネシ*/M5	SCREW	2
8	4805	ナツト (M5)	NUT	2
9	204585	サ*カ*ネ	WASHER	2
10	300038	アクチエ-ター(クミ)	ACTUATOR COMPLETE	1
11	4009-1	ヒラネシ*/C5	SCREW	1
12	300042	アクチエ-ターヒンジ*ハ*ネ	ACTUATOR HINGE SPRING	1
13	1170	ヒラネシ*/C4	SCREW	1
14	3091	ロツカクナツト/C4	NUT	1
15	601001	ハ*フ*ツキ*テ(BF5)	AIR VALVE JOINT	1
16	601049	エアホ-スシ*ヨイント	JOINT	1
17	608002	ワイヤ-ハ*ント*	WIRE BAND	1
18	5117	ヒラネシ*/C5	SCREW	1
19	201185	サ*カ*ネ	WASHER	1
20	300043	アクチエ-ター ヒキ*ハ*ネ	ACTUATOR SPRING	1
21	126	クサリ/マル	CHAIN	1
22	600006A	スイヨミホ-ス	SUCTION TUBE	1
23	600007A	トシユツホ-ス	EXHAUST TUBE	1
24	300104A	リントコレクター(クミ)	WASTE RECEPTACLE COMPLETE	1
25	300105	リントコレクター(ウエ)	WASTE RECEPTACLE CAP	1
26	300106	リントコレクター(シタ)	WASTE RECEPTACLE	1
27	300107A	フィルタ-	AIR FILTER	1
28	300108	トメワ	RING	1
29	300110	フ*ラケツト(B)クミ	BRACKET COMPLETE	1
30	300109	フ*ラケツト(B)	BRACKET	1
31	4300	ロツカクネシ*/M5	SCREW	2
32	4805	ナツト (M5)	NUT	2
33	204585	サ*カ*ネ	WASHER	2
34	4910	モクネシ*	SCREW	2
35	4113	ヒラネシ*	SCREW	3
36	4803	ナツト (M4)	NUT	3
37	303448	サ*カ*ネ	WASHER	6
38	300365	フィルタ-ウケ	FILTER SUPPORT	1

R53-/TK

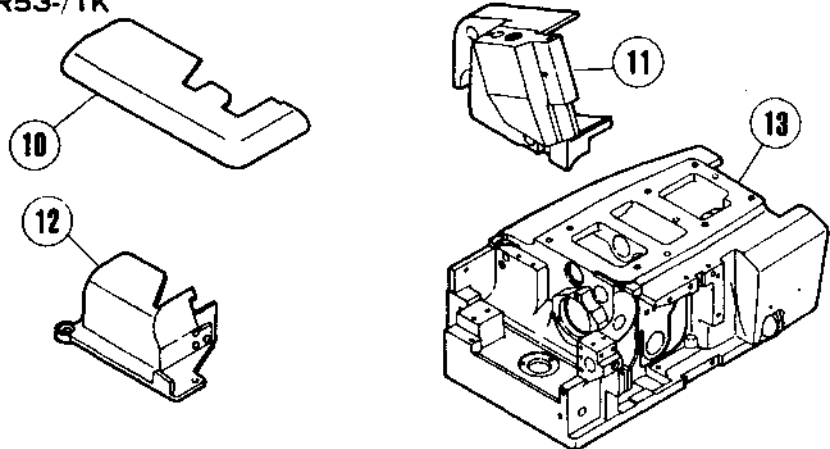

E32-52-/TK

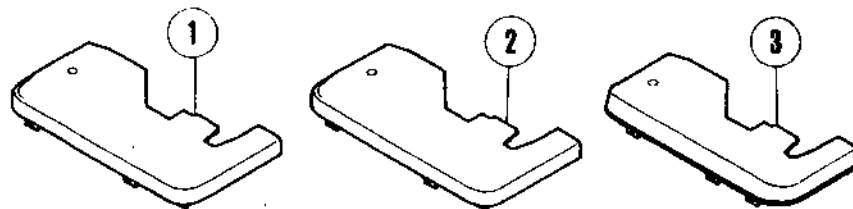

L132-/TK

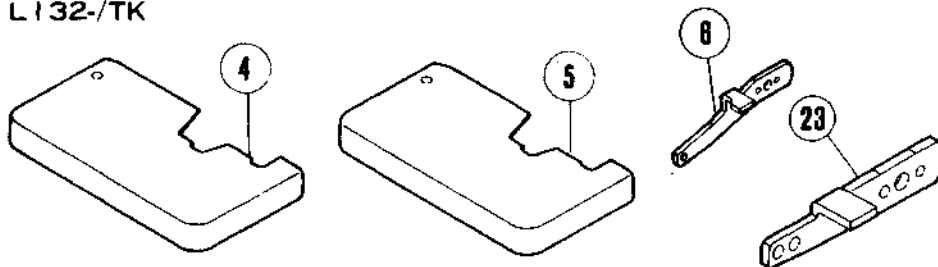

W61-41-02/TK

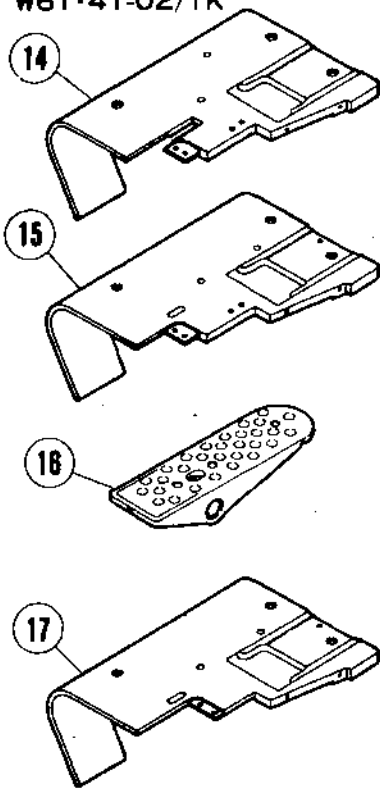

WS62-42/TK

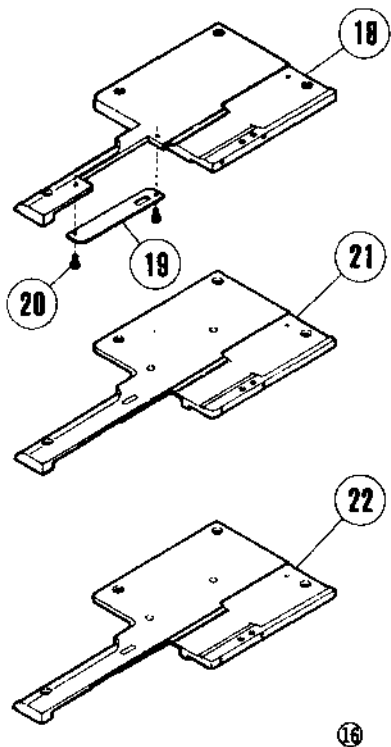

L32-/TK

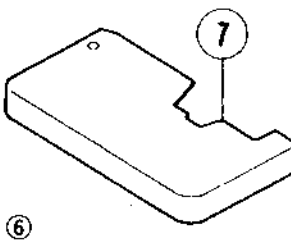

L152-L52-/TK

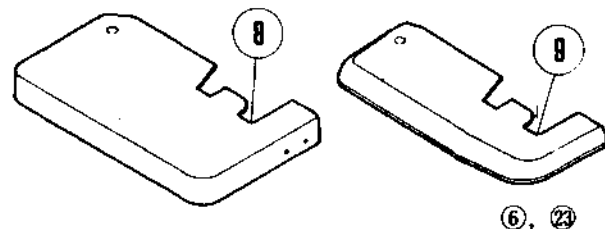

WS62-42-05/TK

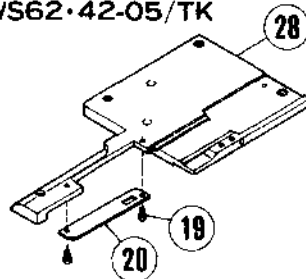

E32-52
ETS32-52
MP センサー
MP SENSOR

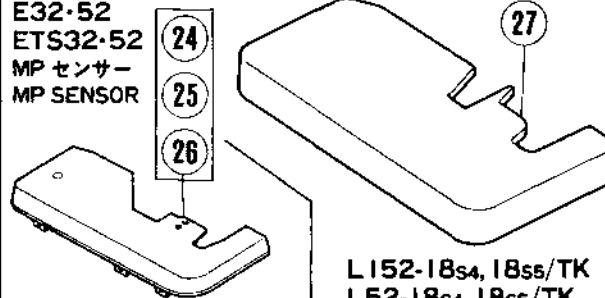

L152-18s4, 18s5/TK
L52-18s4, 18s5/TK

TK装置専用のミシン部品

SPECIFIC MACHINE PARTS
(FOR TK DEVICE ONLY)

REF. NO.	PART NO.	メキシコ	NAME	QT.
1	301157	クロスプレート(2Nヨウ)	CLOTH PLATE (2N)	1
2	301143	クロスプレート(2Nイカイ)	CLOTH PLATE (EXCEPT 2N)	1
3	301145	クロスプレート(ハナセツ)	CLOTH PLATE (NARROW)	1
4	303802	クロスプレート(2Nヨウ)	CLOTH PLATE (2N)	1
5	303800	クロスプレート(2Nイカイ)	CLOTH PLATE (EXCEPT 2N)	1
6	303854	レハ-ノアシアケ	FOOT LIFTING LEVER	1
7	303432	クロスプレート	CLOTH PLATE	1
8	303431	クロスプレート(ハナヒロ)	CLOTH PLATE (WIDE)	1
9	303433	クロスプレート(ハナセツ)	CLOTH PLATE (NARROW)	1
10	300066	クロスプレート	CLOTH PLATE	1
11	300296-FD	ア-ム(B)	MACHINE ARM (LEFT)	1
12	300297	オクリタ-イカハ-	FEED BAR COVER	1
13	300301	ハツト	BED	1
14	306024	ウシロカハ-	REAR COVER	1
15	306724-FD	ウシロカハ-	REAR COVER	1
16	478	ペダル	PEDAL	1
17	306726-FD	ウシロカハ-	REAR COVER	1
18	306588-FD	ヒラカハ-	BED COVER	1
19	306589	キリクスウケカハ-	CHIP COVER	1
20	1227	ヒラネシ/C3	SCREW	2
21	306725-FD	ヒラカハ-	BED COVER	1
22	306727-FD	ヒラカハ-	BED COVER	1
23	303130	レハ-ノアシアケ	FOOT LIFTING LEVER	1
24	301887	クロスプレート(ハナセツ)	CLOTH PLATE (NARROW)	1
25	301889	クロスプレート(ハナヒロ)	CLOTH PLATE (WIDE)	1
26	301891	クロスプレート(2Nヨウ)	CLOTH PLATE (2N)	1
27	304077	クロスプレート	CLOTH PLATE	1
28	306613	ヒラカハ-	BED COVER	1

W61-41-02/AT

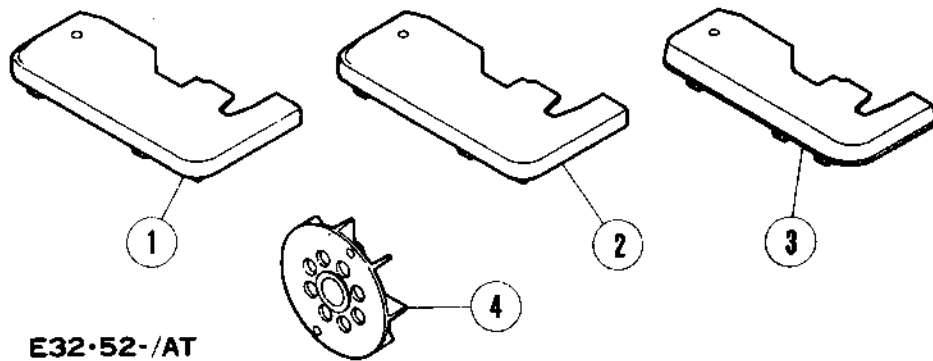
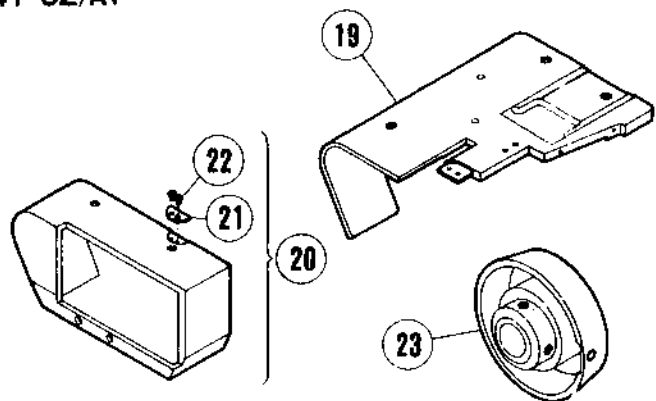

E32-52-/AT

WS62-42-02/AT

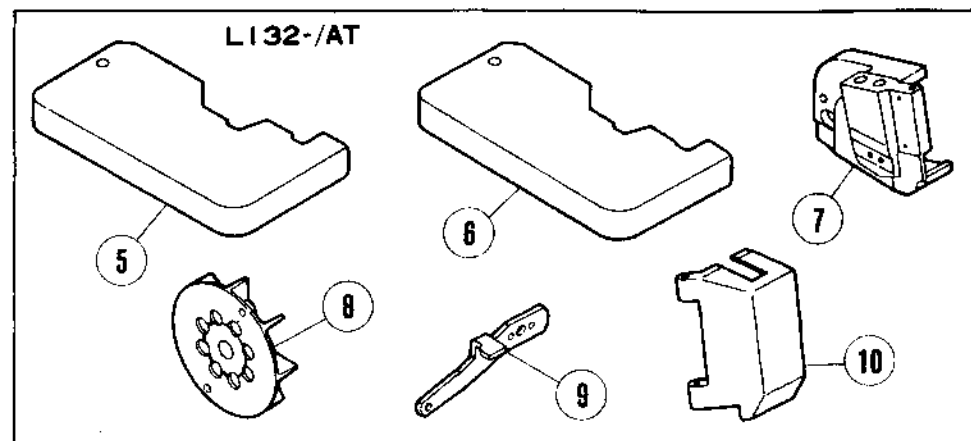
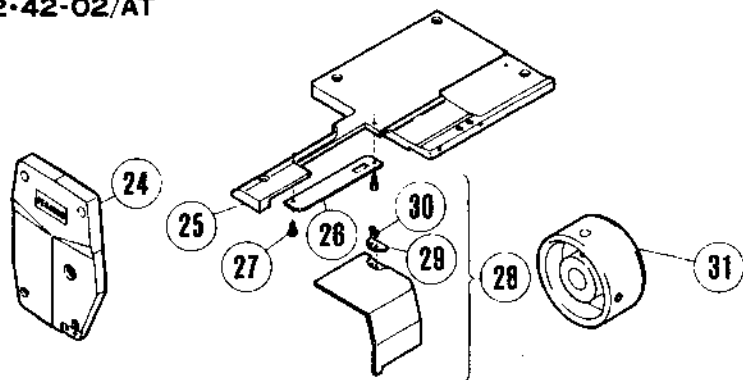

L132-/AT

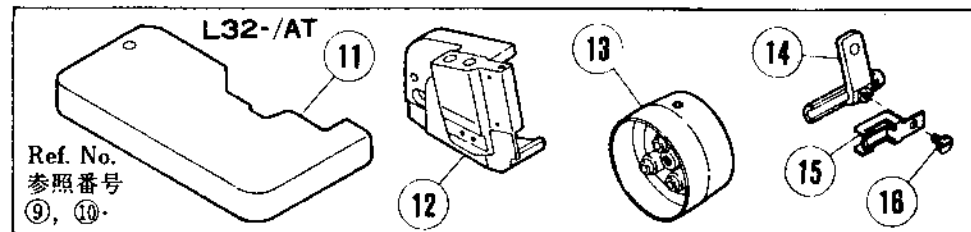

L32-/AT

Ref. No.
参照番号
⑨, ⑩

L52

Ref. No.
参照番号

⑨, ⑩, ⑫, ⑬, ⑭, ⑮, ⑯, ⑰, ⑱

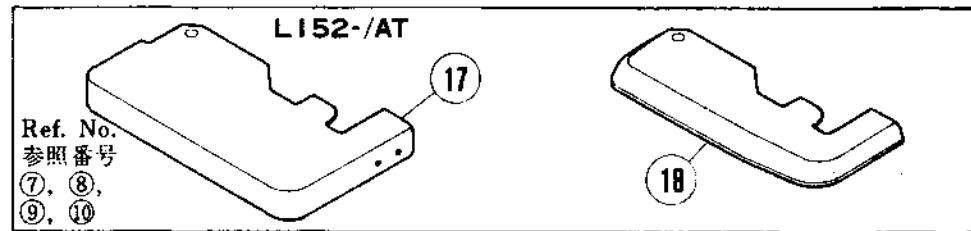

L152-/AT

Ref. No.
参照番号
⑦, ⑧,
⑨, ⑩

AT装置専用のミシン部品

SPECIFIC MACHINE PARTS
(FOR AT DEVICE ONLY)

REF. NO.	PART NO.	メイショウ	NAME	QT.
1	301243	クロスプレート/ハリイタ2Nヨウ	CLOTH PLATE/FEED TYPE 2N	1
2	301241	クロスプレート/ハリイタ2Nイカ ^イ	CLOTH PLATE	1
3	301181	クロスプレート/ハリイタ ^{セマ}	CLOTH PLATE (NARROW)	1
4	301274	ファン	FAN	1
5	303764	クロスプレート/ハリイタ2Nヨウ	CLOTH PLATE/FEED TYPE 2N	1
6	303777	クロスプレート/ハリイタ2Nイカ ^イ	CLOTH PLATE	1
7	303424-HD	アーム/ヒタ ^リ	MACHINE ARM (LEFT)	1
8	303729	ファン	FAN	1
9	303854	レハ ^キ / アシアゲ ^キ	FOOT LIFTING LEVER	1
10	303812	ハリイタカバー	COVER/NEEDLE THREAD	1
11	303758	クロスプレート	CLOTH PLATE	1
12	303424-FD	アーム/ヒタ ^リ	MACHINE ARM (LEFT)	1
13	303421	プーリー/フタ	PULLEY CAP	1
14	303714	シリコンパイプ/ウエ	PIPE (SILICONE OIL)	1
15	303708	アテカ ^ネ	SPACER	1
16	5077	ヒラネジ ^キ	SCREW	1
17	303808	クロスプレート/ハリイタ ^{ヒロ}	CLOTH PLATE (WIDE)	1
18	303810	クロスプレート /ハリイタ ^{セマ}	CLOTH PLATE (NARROW)	1
19	306024	ウシロカバー	REAR COVER	1
20	306969	ヒラカバー	BED COVER	1
21	306256	ハコシヤカバー	REFLECTION PLATE	1
22	5304	サラネジ ^キ / C1	SCREW	2
23	306260	ハンドホイール	HANDWHEEL	1
24	306618	フェイス	FACE PLATE	1
25	306588	ヒラカバー	BED COVER	1
26	306589	チップカバー	CHIP COVER	1
27	1227	ヒラネジ ^キ / C3	SCREW	2
28	306617	クロスプレート	CLOTH PLATE	1
29	306256	ハコシヤカバー	REFLECTION PLATE	1
30	5304	サラネジ ^キ / C1	SCREW	2
31	307072-FD	ハンドホイール	HANDWHEEL	1

E32AT GAUGE PARTS

CPセンサ用 (For CP sensor)

E32ATゲージパーツ

Machine type	Specification gauge	Needle holder	Needle plate	Main feed dog complete	Diff. feed dog	Presser foot		Upper looper	Upper spreader	Factory set needle
						complete	fabric guard			
形 式	仕 様 ゲージ	針 留	針 板	主送り歯(組)	差動送り歯	押エ(組)	補助押エ	上ルーバー	上スプレッダー	針 番 手
E32-420	516-213-3×4	210273	301318	210579	210492	* 301303	208531	210364	210512	DC×27 #11
E32-430	516-233-3×4	210273	301319	210581	210494	* 301300	"	210365	210513	DC×27 #14
	" 5×5	210274	301320	"	"	301301	"	"	"	"
E32-450	516-335-5×6	210274	301321	210582	210495	301304	204683	"	210512	DC×27 #21
E32-410	516-212-2×4	210272	301317	210892	210889	301302	208531	210364	"	DC×27 #11
E32-411	516-232-3×4	210273	301319	210893	210890	* 301300	"	"	"	DC×27 #11

注) *印にはテープ入押エ301305(送り形式:3W)、301306(送り形式:3N)があります。

Note) The taping feet #301305 (used for the feed type 3W) and #301306 (used for the feed type 3N) are available as option.

E52AT GAUGE PARTS

CPセンサ用 (For CP sensor)

E52ATゲージパーツ

Machine type no.	Specification gauge	Needle plate	Main feed dog complete	Diff. feed dog	Presser foot			Needle holder	Lower knife	Upper looper	Needle guard		Needle
					body	finger	fab. guard				front	rear	
型 式	仕 様 ゲージ	針 板	主送り歯(組)	差動送り歯	押エ	押エ爪	補助押エ	針 留	下メス	上ルーバー	針受前	針受後	針
E52-130	504-263-N 4	301314	210574	210445	* 301298	210371	201265 B	210247	202295	210364 #22	210251	210724	DC×27 #9
E52-132	514-363-W 2×3	301315	"	"	* 301298	210503	"	210248	"	210365 #24	210252	"	DC×27 #11
E52-133	514-363-N 2×3	301315	"	"	* 301298	"	"	"	"	210365 #24	"	"	DC×27 #9
E52-140	514-385-W 2×4	301316	210576	210448	* 301298	210374	"	"	"	210729 #30	"	"	DC×27 #14
E52-250	514-363-N 2×3	301315	210574	210445	301299	---	---	211360	"	210365 #24	"	"	DC×27 #9
E52-250C	514-363-W 2×3	301315	"	"	"	---	---	"	"	210365 #24	"	"	DC×27 #9
E52-252	514-463-W 2×3	301315	211927-BF	211929-BF	301632	210503	211557	"	"	211720 #40	"	"	DC×27 #11

注) *印にはテープ入押エ301299があります。

Note) The taping foot #301299 is available as option.

E32AT GAUGE PARTS

MPセンサ用 (For MP sensor)

E32ATゲージパーツ

Machine type	Specification gauge	Needle holder	Needle plate	Main feed dog complete	Diff. feed dog	Presser foot		Upper looper	Upper spreader	Factory set needle
						complete	fabric guard			
形 式	仕 様 ゲージ	針 留	針 板	主送り歯(組)	差動送り歯	押エ(組)	補助押エ	上ルーバー	上スプレッダー	針 番 手
E32-420	516-213-3×4	210273	301200	210579	210492	208504	208531	210364	210512	DC×27 #11
E32-430	516-233-3×4	210273	301208	210581	210494	208501	"	210365	210513	DC×27 #14
	" 5×5	210274	301213	"	"	208502	"	"	"	
E32-450	516-335-5×6	210274	301216	210582	210495	208955	204683	"	210512	DC×27 #21
E32-410	516-212-2×4	210272	301196	210892	210889	208503	208531	210364	"	DC×27 #11
E32-411	516-232-3×4	210273	301208	210893	210890	208501	"	"	"	DC×27 #11

E52AT GAUGE PARTS

MPセンサ用 (For MP sensor)

E52ATゲージパーツ

Machine type no.	Specification gauge	Needle plate	Main feed dog complete	Diff. feed dog	Presser foot			Needle holder	Lower knife	Upper looper	Needle guard		Needle
					body	finger	fab. guard				front	rear	
型 式	仕 様 ゲージ	針 板	主送り歯(組)	差動送り歯	押エ	押エ爪	補助押エ	針 留	下メス	上ルーバー	針受前	針受後	針
E52-130	504-263-N 4	301064	210574	210445	201230 C	210371	201265 B	210247	202295	210364 #22	210251	210724	DC×27 #9
E52-132	514-363-W 2×3	301072	"	"	"	210503	"	210248	"	210365 #24	210252	"	DC×27 #11
E52-133	514-363-N 2×3	301072	"	"	"	"	"	"	"	210365 #24	"	"	DC×27 #9
E52-140	514-385-W 2×4	301086	210576	210448	"	210374	"	"	"	210729 #30	"	"	DC×27 #14
E52-250	514-363-N 2×3	301072	210574	210445	208730	208731	—	211360	"	210365 #24	"	"	DC×1 #9
E52-250C	514-363-W 2×3	"	"	"	"	"	—	"	"	210365 #24	"	"	DC×1 #9

L132AT GAUGE PARTS

CPセンサ用 (For CP sensor)

L132ATゲージパーツ

Machine model	Gauge(mm) NG×SW	Needle plate	Main feed dog complete	Diff. feed dog	Presser foot complete	Presser foot fabric guard	Upper looper for 5-thread		Double chainstitch			Needle bar complete	Upper knife	Feed dog	
							mark	looper	needle guard		Type			Tooth pitch	
機種	ゲージ(mm) NG×SW	針板	主送り歯 (組)	差動送り歯	押エ(組)	補助押エ	上ルーバー 5本系用	刻印	二重環 ルーバー	針受(C)	針受(D)	針 株	上メス	送り歯 形式 ピッチ	
L132-36 (L132-37)	3×4	303833	208065	208218	301303	208531	204062	2	204314 A	204536	208653	208909	202527 A	2 N	1.0mm
L132-70 (L132-71)	5×5	303834	208063	208215	301301	"	204702	4	204431	204042	208654	208910	201121 A	2 W	1.6mm
L132-86 (L132-87)	5×6	303835	208064	208217	301304	204683	204703	6	"	"	"	"	"	2 W	2.5mm
L132-38 (L132-39)	3×4	303833	208066	208219	301303	208531	204702	4	204314 A	204536	208653	208909	202527 A	2 N	1.6mm

L32AT GAUGE PARTS

CPセンサ用 (For CP sensor)

L32ATゲージパーツ

Machine model	Gauge(mm) NG×SW	Needle plate	Main feed dog complete	Diff. feed dog	Presser foot complete	Presser foot fabric guard	Upper looper for 5-thread		Double chainstitch			Needle bar complete	Upper knife	Feed dog	
							mark	looper	needle guard		Type			Tooth pitch	
機種	ゲージ(mm) NG×SW	針板	主送り歯 (組)	差動送り歯	押エ(組)	補助押エ	上ルーバー 5本系用	刻印	二重環 ルーバー	針受(C)	針受(D)	針 株	上メス	送り歯 形式 ピッチ	
L32-36 (L32-37)	3×4	303839	208065	208218	301303	208531	204062	2	204314 A	204536	—	208909	202527 A	2 N	1.0mm
L32-70 (L32-71)	5×5	303840	208063	208215	301301	"	204702	4	204431	204042	204522	208910	201121 A	2 W	1.6mm
L32-86 (L32-87)	5×6	303841	208064	208217	301304	204683	204703	6	"	"	"	"	"	2 W	2.5mm
L32-38 (L32-39)	3×4	303839	208066	208219	301303	208531	204072	4	204314 A	204536	204521	208909	202527 A	2 N	1.6mm

L152AT・L52AT GAUGE PARTS

CPセンサ用 (For CP sensor)

L152AT・L52AT ゲージパーツ

Machine model	Gauge (seam width)	Needle plate	Main feed dog	Auxiliary feed dog	Differential feed dog	Presser foot				Needle holder	Needle guard		Upper looper		Lower knife	Needle	Feed pattern	tooth pitch	Diff. feed ratio
						body	chaining off figer	fabric guard	uncurler		front	rear	mark						
機種	ゲージ SW (縫巾)	針板	主送り歯	補助送り歯	差動送り歯	押エ	押エ爪	補助押エ	押エ補助板	針株	針受(前)	針受(後)	上ルーバー	刻印	下メス	針	送り形式	送り歯ピッチ	差動比
L152-17 L52-17	4	303828	204675 A	204674	204676	301298	201224 B	201265 B	204668	-----	204634	209009	204062	2	201127	DC×1 #9	3 L	1.6mm	2:1
L152-26 L52-26	4	"	204678 A	"	204691	"	"	"	"	-----	"	"	204702	4	"	DC×1 #14	3 L	2.5mm	3:1
L152-27 L52-27	4	"	"	"	204679	"	"	"	"	-----	"	204635	204703	6	"	DC×1 #18	3 L	2.5mm	2:1
L152-28 L52-28	4	"	204675 A	"	204690	"	"	"	"	-----	"	209009	204062	2	"	DC×1 #11	3 L	1.6mm	3:1
L152-12 L52-12	2×3 2×4	303830 303829	"	"	"	301299	208731 208732	"	"	208905	204659	"	204963	8	202295	DC×1 #11	3 L	1.6mm	3:1
L152-13 L52-13	2×3 2×4	303830 303829	"	"	204676	"	208731 208732	"	"	"	"	"	204949	11	"	DC×1 #9	3 L	1.6mm	2:1
L152-23 L52-23	2×3 2×4	303830 303829	204678 A	"	204691	"	208731 208732	"	"	"	"	"	204964	9	"	DC×1 #14	3 L 3 W	2.5mm	3:1
L152-11 L52-11	2×3 2×4	303830 303829	204675 A	"	204676	301298	201396 B 201310 A	201265 B	"	"	"	"	204702	4	"	DC×1 #11	3 L	1.6mm	2:1

R53TK GAUGE PARTS

R53TKゲージパーツ表

機種	ゲージ		針板	主送り歯	差動送り歯	補助送り歯	押エ	押エ爪	補助板	補助押エ	上ルーバー	下メス	針留	送りエキセン		使用針	
	NG	SM												主	差動	タイプ	サイズ
MACHINE MODEL	GAUGE	NEEDLE PLATE	MAIN FEED DOG	DIFF. FEED DOG	AUX. FEED DOG	PRESSER FOOT		UNCURLER	FAB. GRD	UPPER LOOPER	LOWER KNIFE	NEEDLE HOLDER	FEED ECC.		NEEDLE		
	NG	SM				BODY	FINGER						MAIN	DIFF.	TYPE	SIZE	
R53-01		2	300076	201094B	201097C	202634A	201152E	201155C	210584		202828	202295		12	10	DCX1	#9
		3	300077	"	"	"	"	"	"	"	#4	"					
		4	300078	"	"	"	"	"	"	"	"	"					
R53-02		2	300076	"	"	"	201473B	201224B	"		"	"		12	10	DCX1	#9
		3	300077	"	"	"	"	"	"	"	"	"					
		4	300078	"	"	"	"	"	"	"	"	"					
R53-03		3	303387	205248	202854A		202799	"	"	201265B	202840	"		5.5	5.5	DCX1	#14
		4	303388	"	"		"	"	"	"	#5	"					
		5	303389	"	"		"	"	"	"	"	"					
		6	303390	"	"		"	"	"	"	"	"					
R53-17		3	300071	202543D	202544D	202634A	201230C	"	"	"	202828	201127		12	10	DCX1	#11
		4	300072	"	"	"	"	"	"	"	#4	"					
		5	300074	"	"	"	"	"	"	"	"	202295					
		6	300075	"	"	"	"	"	"	"	"	"					
R53-53		3	300090	205249	202535C		205252	"	301335	"	"	201127		12	10	DCX1	#11
		4	300091	"	"		"	"	"	"	"	"					
		5	300092	"	"		"	"	"	"	"	202295					
		6	300093	"	"		"	"	"	"	"	"					
R53-54		3	303387	202798	202854A		202799	"	210584	"	"	201127		12	10	DCX1	#14
		4	303388	"	"		"	"	"	"	"	"					
		5	303389	"	"		"	"	"	"	"	202295					
		6	303390	"	"		"	"	"	"	"	"					
R53-57		3	303253	205250	202544D		205253	"	301335	"	"	201127		12	10	DCX1	#14
		4	303254	"	"		"	"	"	"	"	"					
		5	303255	"	"		"	"	"	"	"	202295					
		6	303256	"	"		"	"	"	"	"	"					
R53-05	1.5	3	300079	201094B	202854A	202634A	201230C	201396B	210584	"	202719	202295	208904	12	10	DCX3	#9
	2	3	300081	"	"	"	"	"	"	"	#6	"	208905			DCX1	#9
	2	4	300080	"	"	"	"	201310A	"	"	"	"	"				
R53-12	2	3	300101	202543D	202544D	"	"	201396B	"	"	"	"		12	10	DCX1	#11
	2	4	300073	"	"	"	"	201310A	"	"	"	"					
R53-15	2	3	300081	201094B	202854A	"	"	201396B	"	"	"	"		6	10	DCX1	#14
	2	4	300080	"	"	"	"	201310A	"	"	"	"					
R53-25	2	2	300102	"	201097C	"	"	201396B	"	"	"	201127	"	12	10	DCX1	#9
	2	3	300103	"	"	"	"	"	"	"	"	"					
R53-52	2	4	300098	205250	202544D		205253	201310A	301335	"	"	202295	"	12	10	DCX1	#11
R53-55	1.5	3	300082	202798	202854A		202799	201396B	210584	"	"	"	208904	12	10	DCX3	#9
	2	3	300083	"	"		"	"	"	"	"	"	208905			DCX1	#9
	2	4	300084	"	"		"	201310A	"	"	"	"	"				
R53-09	2	3	300081	201094B	"	202634A	201230C	201396B	"	"	202828	"		12	10	DCX1	#11
	2	4	300080	"	"	"	"	201310A	"	"	#4	"					
R53-11	2	3	300101	202543D	202544D	"	"	201396B	"	"	"	"		12	10	DCX1	#14
	2	4	300073	"	"	"	"	201310A	"	"	"	"					
	2	5	300070	"	"	"	"	"	"	"	"	"					
R53-51	2	4	300098	205250	"		205253	"	301335	"	"	"		12	10	DCX1	#14
	2	5	300099	"	"		"	"	"	"	"	"					
R53-59	2	3	300083	202798	202854A		202799	201396B	210584	"	"	"		12	10	DCX1	#11
	2	4	300084	"	"		"	201310A	"	"	"	"					

E52TK GAUGE PARTS

E52TKゲージパーツ表

MACHINE TYPE/SPEC.	GAUGE		NEEDLE PLATE	MAIN FEED DOG COMP.	DIFF. FEED DOG	PRESSER FOOT			LOWER KNIFE	UPPER LOOPER	NEEDLE GUARD		NEEDLE HOLDER	NOL SIZE
	NG	SM				BODY	FINGER	FAB. GRD			(FRONT)	(REAR)		
	7" - 5"			シイツリハ	サトウ					ハリウケ	ハリウケ		ハリ	
	NG	SM	ハリウケ	(クミ)	イツリハ	イサヒ	イサイツメ	ホシヨサヒ	シメス	ウツルハ	(マ)	(ウツロ)	ハリツメ	サイズ
E52-130/504-253-W		3	301067	210575	210445	205253	210370	201265B	201127	210365	210251	210724	211358	#14
		4	301068	"	"	"	210371	"	202295	" #24	"	"	"	
		5	301069	"	"	"	"	"	"	"	"	"	"	
		6	301070	"	"	"	210372	"	"	"	"	"	"	
E52-130/504-263-N		3	301063	210574	"	201230C	210370	"	201127	210364	"	"	"	#9
		4	301064	"	"	"	210371	"	202295	" #22	"	"	"	
		5	301065	"	"	"	"	"	"	"	"	"	"	
		6	301066	"	"	"	210372	"	"	"	"	"	"	
E52-131/512-353-W	2	2	301075	210575	"	205253	210373	"	"	210368	210252	"	"	#14
	2	3	301076	"	"	"	210503	"	"	" #34	"	"	"	
	2	4	301077	"	"	"	210374	"	"	"	"	"	"	
	2	5	301078	"	"	"	"	"	"	"	"	"	"	
E52-131/514-353-W	2	2	301075	"	"	"	210373	"	"	210365	"	"	211360	#11
	2	3	301076	"	"	"	210503	"	"	" #24	"	"	"	
	2	4	301077	"	"	"	210374	"	"	"	"	"	"	
	2	5	301078	"	"	"	"	"	"	"	"	"	"	
E52-132/514-363-W	2	2	301071	210574	"	201230C	210373	"	"	"	"	"	"	#11
	2	3	301072	"	"	"	210503	"	"	"	"	"	"	
	2	4	301073	"	"	"	210374	"	"	"	"	"	"	
	2	5	301074	"	"	"	"	"	"	"	"	"	"	
E52-133/514-363-N	2	2	301071	"	"	"	210373	"	"	"	"	"	"	#9
	2	3	301072	"	"	"	210503	"	"	"	"	"	"	
	2	4	301073	"	"	"	210374	"	"	"	"	"	"	
	2	5	301074	"	"	"	"	"	"	"	"	"	"	
E52-134/504-233-W		3	301054	210697	210443	202799	210370	"	"	"	210251	"	211358	#14
		4	301055	"	"	"	210371	"	"	"	"	"	"	
		5	301056	"	"	"	"	"	"	"	"	"	"	
		6	301057	"	"	"	210372	"	"	"	"	"	"	
E52-135/512-373-W	2	3	301093	210575	210447	"	210503	"	201127	210368	210252	"	211360	#14
	2	4	301094	"	"	"	210374	"	202295	" #34	"	"	"	
	2	5	301095	"	"	"	"	"	"	"	"	"	"	
	2.5	2.5	301096	"	"	"	210375	"	201127	"	210253	"	211361	
	2.5	3.5	301097	"	"	"	"	"	202295	"	"	"	"	
	3	3	301099	"	"	"	"	"	"	"	210254	"	211362	
	3	4	301100	"	"	"	210376	"	"	"	"	"	"	
E52-136/504-253-W		3	301481	211263	210445	205252	210370	"	201127	210364	210251	"	211358	#11
		4	301482	"	"	"	210371	"	202295	" #22	"	"	"	
		5	301483	"	"	"	"	"	"	"	"	"	"	
		6	301484	"	"	"	210372	"	"	"	"	"	"	
E52-137/514-323-N	2	2	301477	210569	210442	201230C	210373	"	"	210365	210252	"	211360	#9
	2	3	301478	"	"	"	210503	"	"	" #24	"	"	"	
	2	4	301479	"	"	"	210374	"	"	"	"	"	"	
E52-140/514-385-W	2	3	301085	210576	210448	"	210503	"	201127	210729	"	"	"	#14
	2	4	301086	"	"	"	210374	"	202295	" #30	"	"	"	
	2	5	301087	"	"	"	"	"	"	"	"	"	"	
	2.5	2.5	301088	"	"	"	210375	"	201127	210730	210253	"	211361	
	2.5	3.5	301089	"	"	"	"	"	202295	"	"	"	"	
E52-121/504-243-N		3	301941	212250-BF	211974-BF	211986	210370	211557	202295	210364	210251	"	211358	#9
		4	301942	"	"	"	210371	"	"	" #22	"	"	"	
		5	301943	"	"	"	"	"	"	"	"	"	"	
		6	301944	"	"	"	210372	"	"	"	"	"	"	

E52TK GAUGE PARTS

E52TKゲージパーツ表

MACHINE TYPE/SPEC.	GAUGE		NEEDLE PLATE	MAIN FEED DOG COMP.	DIFF. FEED DOG	PRESSER FOOT			LOWER KNIFE	UPPER LOOPER	NEEDLE GUARD		NEEDLE HOLDER	NDL SIZE
	NG	SM				BODY	FINGER	FAB. GRD			(FRONT)	(REAR)		
ミシナキイシキ/シヨク	7" - 5"		ハリイダ	シヨクコバ	サトウ	オキ	オキツメ	ホシヨオキ	シヨク	ウツルハ	ハリウケ (マ)	ハリウケ (ウシロ)	ハリツメ	サイス
E52-210/505-223-N	2	3	301050	210569	210442	201152E	201155C	-----	202295	210364 #22	210251	210724	211358	#9
	4		301052	"	"	"	"	-----	"	"	"	"	"	"
	5		301053	"	"	"	"	-----	"	"	"	"	"	"
E52-211/503-223-N	2	3	301050	"	"	"	"	-----	"	210512 #21	"	"	"	#9
	4		301052	"	"	"	"	-----	"	"	"	"	"	"
	5		301053	"	"	"	"	-----	"	"	"	"	"	"
E52-220/503-233-W	3	4	301054	210568	210443	202799	210370	201265B	"	210513 #23	"	"	"	#14
	5		301055	"	"	"	210371	"	"	"	"	"	"	"
	6		301056	"	"	"	"	"	"	"	"	"	"	"
	6		301057	"	"	"	210372	"	"	"	"	"	"	"
E52-221/504-365-W	3	4	301063	210576	210446	201230C	210370	"	201127	210365 #24	"	"	"	#18
	5		301064	"	"	"	210371	"	202295	"	"	"	"	"
	6		301065	"	"	"	"	"	"	"	"	"	"	"
	6		301066	"	"	"	210372	"	"	"	"	"	"	"
E52-231/504-223-N	1.5		301480	211290	210442	"	205525	"	"	210364	"	"	"	#11
E52-242/504-253-W	3	4	301067	210996	210959	205135	-----	-----	201127	" #22	"	"	"	#11
	5		301068	"	"	"	-----	-----	202295	"	"	"	"	"
	6		301069	"	"	205136	-----	-----	"	"	"	"	"	"
	6		301070	"	"	"	-----	-----	"	"	"	"	"	"
E52-242/504-263-W	3	4	301063	210997	"	205135	-----	-----	201127	"	"	"	"	#11
	5		301064	"	"	"	-----	-----	202295	"	"	"	"	"
	6		301065	"	"	205136	-----	-----	"	"	"	"	"	"
	6		301066	"	"	"	-----	-----	"	"	"	"	"	"
E52-243/512-353-W	2	2	301075	210996	"	205135	-----	-----	"	210368 #34	210252	"	211360	#11
	2	3	301076	"	"	205136	-----	-----	"	"	"	"	"	"
	2	4	301077	"	"	"	-----	-----	"	"	"	"	"	"
	2	5	301078	"	"	"	-----	-----	"	"	"	"	"	"
E52-243/512-363-W	2	2	301071	210997	"	205135	-----	-----	"	"	"	"	"	#11
	2	3	301072	"	"	205136	-----	-----	"	"	"	"	"	"
	2	4	301073	"	"	"	-----	-----	"	"	"	"	"	"
	2	5	301074	"	"	"	-----	-----	"	"	"	"	"	"
E52-243/514-353-W	2	2	301075	210996	"	205135	-----	-----	"	210365 #24	"	"	"	#11
	2	3	301076	"	"	205136	-----	-----	"	"	"	"	"	"
	2	4	301077	"	"	"	-----	-----	"	"	"	"	"	"
	2	5	301078	"	"	"	-----	-----	"	"	"	"	"	"
E52-243/514-363-W	2	2	301071	210997	"	205135	-----	-----	"	"	"	"	"	#11
	2	3	301072	"	"	205136	-----	-----	"	"	"	"	"	"
	2	4	301073	"	"	"	-----	-----	"	"	"	"	"	"
	2	5	301074	"	"	"	-----	-----	"	"	"	"	"	"
E52-261/504-403-W	8		301600	211832	211833	211835	-----	-----	211661	211719 #38	210251	"	"	#18
E52-250/514-363-N	2	3	301072	210574	210445	208730	-----	-----	202295	210365 #24	210252	"	211360	#9
E52-250C/514-363-W	2	3	"	"	"	"	-----	-----	"	"	"	"	"	#9
E52-252/514-463-W	2	3	"	211927-BF	211929-BF	211930	210503	211557	"	211720 #40	"	"	"	#11

L52TK・L152TK GAUGE PARTS

L52TK・L152TKゲージパーツ表

機種	ゲージ SM	針板	主送り歯	補助送り歯	差動送り歯	押エ	押エ爪	補助押エ	押エ補助板	ドメス	上ローパー	針受(前)	針受(後)	針留	針
MACHINE MODEL	GAUGE SM	NEEDLE PLATE	MAIN FEED DOG	AUX. FEED DOG	DIFF. FEED DOG	PRESSER FOOT BODY	FINGER	FAB.GRD	UNCURLER	LOWER KNIFE	UPPER LOOPER	NEEDLE GUARD FRONT	NEEDLE GUARD REAR	NEEDLE HOLDER	NEEDLE NEEDLE
L52-01 L152-01	2 3 4 5	300076 300077 300078 303246	204729A " " "	204674 " " "	204730 " " "	201152E " " "	201155C " " "	----- " " "	210584 " " "	202295 " " "	204062 #2 " "	204634 " " "	209009 " " "	----- " " "	DCX1 #9
L52-01S1 L152-01S1	2 3 4 5	300076 300077 300078 303246	" " " "	" " " "	204977 " " "	" " " "	" " " "	----- " " "	" " " "	" " " "	" " " "	" " " "	" " " "	DCX1 #9	
L52-02 L152-02	2 3 4 5	300076 300077 300078 303246	" " " "	" " " "	204730 " " "	201473B " " "	201224B " " "	----- " " "	" " " "	" " " "	" " " "	" " " "	" " " "	DCX1 #9	
L52-03 L152-03	3 4 5 6	303387 303388 303389 303390	208336 " " "	208338 " " "	204907 " " "	202799 " " "	" " " "	201265B " " "	" " " "	" " " "	204704 #3 " "	" " " "	" " " "	----- " " "	DCX1 #14
L52-17 L152-17	3 4 5 6	300071 300072 300074 300075	204675A " " "	204674 " " "	204676 " " "	201230C " " "	" " " "	" " " "	204668 " " "	201127 " 202295 "	204062 #2 " "	" " " "	" " " "	----- " " "	DCX1 #9
L52-24 L152-24	3 4 5 6	303253 303254 303255 303256	208337 " " "	208338 " " "	204690 " " "	202799 " " "	" " " "	" " " "	210584 " " "	201127 " 202295 "	204704 #3 " "	" " " "	" " " "	----- " " "	DCX1 #14
L52-26 L152-26	3 4 5 6	300071 300072 300074 300075	204678A " " "	204674 " " "	204691 " " "	201230C " " "	" " " "	" " " "	204668 " " "	201127 " 202295 "	204702 #4 " "	" " " "	" " " "	----- " " "	DCX1 #14
L52-27 L152-27	3 4 5 6 7 8	300071 300072 300074 300075 303259 300085	" " " " " "	" " " " " "	204679 " " " " "	" " " " " "	" " " " " "	" " " " " "	" " " " " "	201127 " 202295 " " "	204703 #6 " " "	" " " " " "	204635 " " " " "	----- " " " " "	DCX1 #18
L52-28 L152-28	3 4 5 6	300071 300072 300074 300075	204675A " " "	" " " "	204690 " " "	" " " "	" " " "	" " " "	" " " "	201127 " 202295 "	204062 #2 " "	" " " "	209009 " " "	----- " " "	DCX1 #11
L52-31 L152-31	3 4 5 6	300071 300072 300074 300075	204723A " " "	" " " "	204724 " " "	205135 " 205136 "	----- " " "	----- " " "	301335 " " "	201127 " 202295 "	" " " "	" " " "	" " " "	----- " " "	DCX1 #11
L52-53 L152-53	3 4 5 6	300090 300091 300092 300093	204721A " " "	204677 " " "	204722 " " "	205252 " " "	201224B " " "	201265B " " "	" " " "	201127 " 202295 "	" " " "	" " " "	" " " "	----- " " "	DCX1 #11
L52-54 L152-54	3 4 5 6	303387 303388 303389 303390	204692A " " "	" " " "	204693 " " "	202799 " " "	" " " "	" " " "	210584 " " "	201127 " 202295 "	204702 #4 " "	" " " "	" " " "	----- " " "	DCX1 #14
L52-57 L152-57	3 4 5 6	303253 303254 303255 303256	204675A " " "	" " " "	204676 " " "	205253 " " "	" " " "	" " " "	301335 " " "	201127 " 202295 "	" " " "	" " " "	" " " "	----- " " "	DCX1 #14

L52TK・L152TK GAUGE PARTS

L52TK・L152TKゲージパーツ表

機種	ゲージ		針板	主送り歯	補助送り歯	差動送り歯	押工	押工爪	補助押工	押工補助板	下メス	上ローパー	針受(前)	針受(後)	針箱	針
	NG	SM														
MACHINE MODEL	GAUGE		NEEDLE PLAGE	MAIN FEED DOG	AUX. FEED DOG	DIFF. FEED DOG	PRESSER FOOT				LOWER KNIFE	UPPER LOOPER	NEEDLE GUARD		NEEDLE HOLDER	NEEDLE
	NG	SM					BODY	FINGER	FAB. GRD	UNCURLER			FRONT	REAR		
L52-05	1.5	2	303247	204692A	204674	204693	201230C	201396B	201265B	204668		204949	204659	209009	208904	DCX3
L152-05	1.5	3	300079	"	"	"	"	"	"	"	"	" #11	"	"	208905	#9
	2	2	300081	"	"	"	"	"	"	"	"	"	"	"	"	DCX1
	2	3	300081	"	"	"	"	"	"	"	"	"	"	"	"	#9
	2	4	300080	"	"	"	"	201030A	"	"	"	"	"	"	"	"
L52-12	2	2	303972	204675A	"	204690	208730	208731	-----	"		204963	"	"	"	DCX1
L152-12	2	3	300101	"	"	"	"	"	"	"		" #8	"	"	"	#11
	2	4	300073	"	"	"	"	208732	"	"	"	"	"	"	"	"
L52-13	2	2	303972	"	"	204676	"	208731	"	"		204949	"	"	"	DCX1
L152-13	2	3	300101	"	"	"	"	"	"	"		" #11	"	"	"	#9
	2	4	300073	"	"	"	"	208732	"	"	"	"	"	"	"	"
L52-15	2	2	300102	204729A	"	204977	201230C	201396B	201265B	"		204964	"	"	"	DCX1
L152-15	2	3	300103	"	"	"	"	"	"	"		" #9	"	"	"	#14
L52-18S4	2	3	209387-30	209384-BF	208095	209385-BF	209386	201396B	-----	211600		209209	204659	"	208905	DCX1
L152-18S4	2	4	" -40	"	"	"	"	201310A	-----	"		"	"	"	"	#11
L52-18S5	2.5	2.5	209388-25	"	"	"	"	208049	-----	"		204990	208051	"	208906	"
L152-18S5	2.5	3.5	" -35	"	"	"	"	"	-----	"		"	"	"	"	"
	2.5	4.5	" -45	"	"	"	"	208050	-----	"		"	"	"	"	"
L52-23	2	2	303972	204678A	204674	204691	208730	208731	-----	204668		"	"	"	208905	DCX1
L152-23	2	3	300101	"	"	"	"	"	-----	"		202295	"	"	"	#14
	2	4	300073	"	"	"	"	208732	-----	"		"	"	"	"	"
	2.5	2.5	303251	208040	"	208044	"	208733	-----	"		201127	"	208051	"	208906
	2.5	4	303252	"	"	"	"	208734	-----	"		202295	"	"	"	"
L52-25	1.5	2	303257	204729A	"	204730	201230C	201396B	201265B	"		204949	204659	"	208904	DCX3
L152-25	1.5	3	303258	"	"	"	"	"	"	"		" #11	"	"	208905	#9
	2	2	300102	"	"	"	"	"	"	"		"	"	"	208905	DCX1
	2	3	300103	"	"	"	"	"	"	"		"	"	"	"	#9
L52-34	2	2	303972	204723A	"	204724	205136	-----	-----	301335		204963	"	"	"	DCX1
L152-34	2	3	300101	"	"	"	"	-----	-----	"		" #8	"	"	"	#11
	2	4	300073	"	"	"	"	-----	-----	"		"	"	"	"	"
L52-52	2	4	300098	204675A	204677	204676	205253	201310A	201265B	"		"	"	"	"	DCX1
L52-55	1.5	3	300082	204692A	"	204693	202799	201396B	"	210584		204949	"	"	208904	DCX3
L152-55	2	3	300083	"	"	"	"	"	"	"		" #11	"	"	208905	DCX1
	2	4	300084	"	"	"	"	201310A	"	"		"	"	"	"	#9
L52-56	3	3	303263	208039	208095	208041	205253	208049	"	301335		"	208053	"	208907	DCX1
L152-56	3	4	303264	"	"	"	"	208050	"	"		"	"	"	"	#9

TK017
TK019

L52-18s4	209387-30A	
L152-18s4	" -40A	TK006
* L52-18s5	209388-25A	TK036
L152-18s5	" -35A	TK066
	" -45A	

L52TK・L152TK GAUGE PARTS

L52TK・L152TKゲージパーツ表

機 種	ゲージ		針 板	主送り歯	補助送り歯	差動送り歯	押 工	押工爪	補助押工	押工補助板	下 ノ ス	上ルーパー	針受(前)	針受(後)	針 留	針
	NG	SM														
MACHINE MODEL	GAUGE		NEEDLE PLAGE	MAIN FEED DOG	AUX. FEED DOG	DIFF. FEED DOG	PRESSER FOOT				LOWER KNIFE	UPPER LOOPER	NEEDLE GUARD		NEEDLE HOLDER	NEEDLE
	NG	SM					BODY	FINGER	FAB.GRD	UNCURLER			FRONT	REAR		
L52-09 L152-09	2	3	303391	208039	204674	208041	201230C	201396B	201265B	20466B	201127	204702	204659	209009	208905	DCx1
	2	4	303392	"	"	"	"	201310A	"	"	"	" #4	"	"	"	#11
	2	5	303393	"	"	"	"	"	"	"	202295	"	"	"	"	"
	3	3	303246	"	"	"	"	208049	"	"	201127	"	208053	"	208907	"
	3	4	303249	"	"	"	"	208050	"	"	202295	"	"	"	"	"
3	5	303250	"	"	"	"	"	"	"	"	"	"	"	"	"	
L52-11 L152-11	2	2	303972	204675A	"	204676	"	201396B	"	"	201127	"	204659	"	208905	DCx1
	2	3	300101	"	"	"	"	"	"	202295	"	"	"	"	"	#11
	2	4	300073	"	"	"	"	201310A	"	"	"	"	"	"	"	"
	2	5	300070	"	"	"	"	"	"	"	"	"	"	"	"	"
L52-29 L152-29	2.5	2.5	303251	208040	"	208044	"	208049	"	"	201127	204663	208051	"	208906	DCx1
	2.5	4	303252	"	"	"	"	208050	"	"	202295	" #7	"	"	"	#14
	2.5	5	303260	"	"	"	"	"	"	"	"	"	"	"	"	"
	3	3	303248	"	"	"	"	208049	"	"	201127	"	208053	"	208907	"
	3	4	303249	"	"	"	"	208050	"	"	202295	"	"	"	"	"
3	5	303250	"	"	"	"	"	"	"	"	"	"	"	"	"	
L52-37 L152-37	2	2	303972	204723A	"	204724	205136	-----	-----	210584	201127	204702	204659	"	208905	DCx1
	2	3	300101	"	"	"	"	-----	-----	"	202295	" #4	"	"	"	#11
	2	4	300073	"	"	"	"	-----	-----	"	"	"	"	"	"	"
	2	5	300070	"	"	"	"	-----	-----	"	"	"	"	"	"	"
L52-51 L152-51	2	4	300096	204675A	204677	204676	205253	201310A	201265b	301335	"	"	"	"	"	DCx1
	2	5	300099	"	"	"	"	"	"	"	"	"	"	"	"	#11
L52-59 L152-59	2	3	303394	208039	208095	208041	202799	201396B	"	210584	201127	"	"	"	"	DCx1
	2	4	303395	"	"	"	"	201310A	"	"	"	"	"	"	"	#11
	2	5	303396	"	"	"	"	"	"	"	202295	"	"	"	"	"
	3	3	303263	"	"	"	205253	208049	"	301335	201127	"	208053	"	208907	"
	3	4	303264	"	"	"	"	208050	"	"	202295	"	"	"	"	"
3	5	303265	"	"	"	"	"	"	"	"	"	"	"	"	"	

ETS32AT GAUGE PARTS

MPセンサ用 (For MP sensor)

ETS32ATゲージパーツ

MACHINE TYPE	GAUGE		NEEDLE PLATE	MAIN FEED DOG COMP.	DIFF. FEED DOG	TOP FEED DOG	PRES. FOOT COMPLETE	UPPER LOOPER	UPPER SPREADER	LOWER LOOPER
	NG	SW								
ミツウチキ/シヨウ	ケ-シ*		ハリイ	シヨウクリハ* (クミ)	サト*ウオクリハ*	ウオクリハ*	オサエ(クミ)	ウ ル-ハ°-	ウ ス°レツタ*	シヨ ル-ハ°-
ETS32-420FA2	3	3	212545A30	212753-16	212755-13F	212661-10F	212662-30	211719	211845	212215
516-413	3	4	" A40	"	"	"	" -40	" #38	" #29	"
515-413	3	5	" A50	"	"	"	" -50	"	"	"
ETS32-430BA2	3	3	212548A30	212684-16	210494A16	212064-BF	212053	211719	211845	212215
/516-433	3	4	" A40	"	"	"	"	" #38	" #29	"
/515-433	3	5	" A50	"	"	"	"	"	"	"
	5	5	212551A50	"	"	"	212056	"	"	"
	5	6	" A60	"	"	"	"	"	"	"
ETS32-432BA2	3	3	212682A30	212684-16	210497A16	212064-BF	212053	211719	211845	212215
/516-453	3	4	" A40	"	"	"	"	" #38	" #29	"
/515-453	3	5	" A50	"	"	"	"	"	"	"
	5	5	212683A50	"	"	"	212056	"	"	"
	5	6	" A60	"	"	"	"	"	"	"
ETS32-432FA2	3	3	212682A30	212684-16	212686-13F	212661-10F	212662-30	211719	211845	212215
/516-453	3	4	" A40	"	"	"	" -40	" #38	" #29	"
/515-453	3	5	" A50	"	"	"	" -50	"	"	"
	5	5	212683A50	"	212687-13F	"	212665-50	"	"	"
	5	6	" A60	"	"	"	" -60	"	"	"
ETS32-432FC2/P1(P2)	3	4	212682A40	212684-16	212686-13F	212745-10F	212741-40	211719	211845	212215
/516-453	3	5	" A50	"	"	"	"	" #38	" #29	"
/515-453	5	5	212683A50	"	212687-13F	212745A10F	212743-50	"	"	"
	5	6	" A60	"	"	"	"	"	"	"
ETS32-452BA2	3	5	212700A50	212684-16	210494A16	212064-BF	212053	211719	211845	212644
/516-433	3	6	" A60	"	"	"	"	" #38	" #29	"
/515-433	5	5	212701A50	"	"	"	212056	"	"	"
	5	6	" A60	"	"	"	"	"	"	"
	5	7	" A70	"	"	"	"	"	"	"
ETS32-453BA2	5	5	212702A50	212684-16	210500A16	212064-BF	212056	211719	211845	212644
/516-453	5	6	" A60	"	"	"	"	" #38	" #29	"
/515-453	5	7	" A70	"	"	"	"	"	"	"
ETS32-542FD2	3	3	212682A30	212684-16	212686-13F	212661-10F	212662-30	211719	211845	212215
/516-453/KL100	3	4	" A40	"	"	"	" -40	" #38	" #29	"
/515-453/KL100	3	5	" A50	"	"	"	" -50	"	"	"
	5	5	212683A50	"	212687-13F	"	212665-50	"	"	"
	5	6	" A60	"	"	"	" -60	"	"	"

ETS32AT GAUGE PARTS

MPセンサ用 (For MP sensor)

ETS32ATゲージパーツ

MACHINE TYPE	GAUGE		401 LOOPER	NEEDLE HOLDER	UPPER KNIFE	LOWER KNIFE	OVR.NDL GUARD		401 NDL GUARD		NEEDLE
	NG	SW					(FRONT)	(REAR)	(FRONT)	(REAR)	
	ケ [*] -ジ [*]		ニシ [*] ユカカ				オ-ハ [*] -ロツ		ニシ [*] ユカカ		
	NG	SW	ル-ハ [*] -	ハリト [*] メ	ウツメス	シツメス	ハリツカ(ツエ)	ハリツカ(ウツロ)	ハリツカ(ツエ)	ハリツカ(ウツロ)	ハリ
ETS32-420FA2 516-413 515-413	3 3 3	3 4 5	210357 " "	210273 " "	201121A " "	202295 " "	210275A " "	210724 " "	210278 " "	210279 " "	DCX27 #11
ETS32-430BA2 /516-433 /515-433	3 3 3 5 5	3 4 5 5 6	210357 " " " "	210273 " " 210274 "	201121A " " " "	202295 " " " "	210275A " " " "	210724 " " " "	210278 " " " "	210279 " " " "	DCX27 #11
ETS32-432BA2 /516-453 /515-453	3 3 3 5 5	3 4 5 5 6	210357 " " " "	210273 " " 210274 "	201121A " " " "	202295 " " " "	210275A " " " "	210724 " " " "	210278 " " " "	210279 " " " "	DCX27 #11
ETS32-432FA2 /516-453 /515-453	3 3 3 5 5	3 4 5 5 6	210357 " " " "	210273 " " 210274 "	201121A " " " "	202295 " " " "	210275A " " " "	210724 " " " "	210278 " " " "	210279 " " " "	DCX27 #11
ETS32-432FC2/P1(P2) /516-453 /515-453	3 3 5 5	4 5 5 6	210357 " " "	210273 " 210274 "	201121A " " "	202295 " " "	210275A " " "	210724 " " "	210278 " " "	210279 " " "	DCX27 #11 "
ETS32-452BA2 /516-433 /515-433	3 3 5 5 5	5 6 5 6 7	210357-HC " " " "	210273 " 210274 " "	201121A " " " "	202295 " " " "	210275A " " " "	210276 " " " "	210278 " " " "	210279 " " " "	OVR:DCX1 #21 401:DCX27 #21
ETS32-453BA2 /516-453 /515-453	5 5 5	5 6 7	210357-HC " "	210274 " "	201121A " "	202295 " "	210275A " "	210276 " "	210278 " "	210279 " "	OVR:DCX1 401:DCX27 #21
ETS32-542FD2 /516-453/KL100 /515-453/KL100	3 3 3 5 5	3 4 5 5 6	210357 " " " "	210273 " " 210274 "	201121A " " " "	202295 " " " "	210275A " " " "	210724 " " " "	210278 " " " "	210279 " " " "	DCX27 #11

ETS52AT GAUGE PARTS

MPセンサ用 (For MP sensor)

ETS52ATゲージパーツ

MACHINE TYPE	GAUGE		NEEDLE PLATE	MAIN FEED DOG COMP.	DIFF. FEED DOG	TOP FEED DOG	PRESSER FOOT		UPPER LOOPER	LOWER LOOPER
	NG	SW					BODY	FINGER		
エス五二アチイ/エス五二	2	5	ナリイ	エス五二アチイ (25)	サト*エス五二アチイ*	エス五二アチイ*	オサエ	オサエツメ	エス五二アチイ#38	エス五二アチイ#38
ETS52-141BA2 /504-463-W		4 5	301064 301065	210574-BF "	210445-BF "	212181-BF "	212133 "	210371 "	211719 " #38	212215 "
ETS52-142BA2 /514-463-W /512-463-W	2 2 2	3 4 5	301072 301073 301074	210574-BF " "	210445-BF " "	212181-BF " "	212133 " "	210503 210374 "	211719 " #38 "	212215 " "
ETS52-142FA2 /514-463-W /512-463-W	2 2 2	3 4 5	301072 301073 301074	210574-BF " "	212572-BF " "	212677-10F " "	212673-30 " -40 " -50	----- ----- -----	211719 " #38 "	212215 " "
ETS52-142FB2/S1(S2) /514-463-W/KL100 /512-463-W/KL100	2 2 2	3 4 5	301072 301073 301074	210574-BF " "	212572-BF " "	212677-10F " "	212673A30 " A40 " A50	----- ----- -----	211719 " #38 "	212215 " "
ETS52-350BC2/P1(P2) /504-453-W		5	301069	212759-16F	211929-BF	212070-BF	212068	211874-TA	211719 #38	212215
ETS52-351FC2/P1(P2) /514-453-W /512-453-W	2	4	301077	212759-16F	212740-13F	212677-10F	212738-40	-----	211719 #38	212215

ETS52AT GAUGE PARTS

MPセンサ用 (For MP sensor)

ETS52ATゲージパーツ

MACHINE TYPE	GAUGE		FOR FST	512 ONLY	NEEDLE HOLDER	UPPER KNIFE	LOWER KNIFE	NEEDLE GUARD		NEEDLE
	NG	SW	UPPER LOOPER	LOWER LOOPER				(FRONT)	(REAR)	
ミヨウカイ/シヨウ	ゲージ*							ハリウカ (2E)	ハリウカ (ウロ)	ハリ
ETS52-141BA2 /504-463-W		4 5	----- -----	----- -----	211358 "	201121A "	202295 "	210252 "	210724 "	DCX27 #11
ETS52-142BA2 /514-463-W /512-463-W	2 2 2	3 4 5	211844 " #42 "	212215 " "	211360 " "	201121A " "	202295 " "	210252 " "	210724 " "	DCX27 #11
ETS52-142FA2 /514-463-W /512-463-W	2 2 2	3 4 5	211844 " #42 "	212215 " "	211360 " "	201121A " "	202295 " "	210252 " "	210724 " "	DCX27 #11
ETS52-142FB2/S1(S2) /514-463-W/KL100 /512-463-W/KL100	2 2 2	3 4 5	211844 " #42 "	212215 " "	211360 " "	201121A " "	202295 " "	210252 " "	210724 " "	DCX27 #11
ETS52-350BC2/P1(P2) /504-453-W		5	-----	-----	211358	201121A	202295	210252	210724	DCX27 #9
ETS52-351FC2/P1(P2) /514-453-W /512-453-W	2	4	211844 #42	212215	211360	201121A	202295	210252	210724	DCX27 #9

PART NO.	PAGE	REF. NO.	PART NO.	PAGE	REF. NO.	PART NO.	PAGE	REF. NO.	PART NO.	PAGE	REF. NO.	PART NO.	PAGE	REF. NO.
125	31	29	4107	45	6	5084	23	15	204586	43	66	301145		5
126	59	21	4109	53	9	5084	25	15	204586	45	13	301145		7
197	37	8	4109	55	12	5084	27	15	204586	45	18	301145		15
197	39	26	4109	55	15	5095	31	6	204586	45	23	301145		17
478	9		4109	55	22	5095	49	47	204586	45	35	301145	61	3
478	19		4110	53	27	5113	27	23	204586	45	44	301157		5
478	61	16	4113	57	20	5113	47	26	204586	45	50	301157		7
1136-HC	25	11	4113	59	35	5116	29	6	206079	55	20	301157		15
1170	59	13	4114	53	25	5117	23	42	208245	49	9	301157		17
1175-3	47	6	4118	35	39	5117	59	18	300001	27	2	301157	61	1
1186	23	11	4118	43	58	5118	39	27	300002	27	17	301160	23	28
1186	23	13	4118	45	39	5183	31	20	300003	27	3	301160	25	27
1186	23	29	4118	45	47	5183	39	29	300006	25	6	301161		2
1186	25	9	4119	35	19	5185	33	16	300006	27	6	301161		4
1186	25	13	4119	43	31	5189	29	22	300008	27	8	301161		12
1186	25	28	4119	43	62	5214	29	7	300011	27	10	301161		14
1186	27	9	4119	45	11	5230	29	39	300033	59	4	301161	23	25
1186-HC	23	7	4119	45	16	5266	25	18	300037	59	6	301163	23	26
1186-HC	23	9	4119	45	43	5266	27	19	300038	59	10	301163	25	36
1186-HC	25	7	4122	35	6	5275	31	16	300042	59	12	301164	23	27
1186-HC	27	7	4122	43	35	5276	23	19	300043	59	20	301164	25	26
1186-HC	27	11	4123	53	4	5276	25	19	300066	9		301165	23	14
1202	49	14	4300	37	9	5276	27	20	300066	19		301165	25	14
1202	49	39	4300	39	32	5304	63	22	300066	61	10	301165	27	14
1202	49	42	4300	57	16	5304	63	30	300104A	57	2	301167	23	17
1216	49	11	4300	59	31	5324	29	23	300104A	59	24	301168		5
1227	3		4301	59	7	5324	31	5	300105	57	3	301168		7
1227	9		4304	29	54	5328	49	25	300105	59	25	301168		15
1227	13		4312	51	21	5328	49	45	300106	57	4	301168		17
1227	19		4328	51	20	5345	23	16	300106	59	26	301168	23	1
1227	61	20	4503	29	41	5345	25	16	300107A	57	5	301170-HD	33	3
1227	63	27	4514	53	21	5345	31	8	300107A	59	27	301171	33	4
1457	29	34	4516	29	48	5345	49	10	300108	57	6	301172	33	6
2902	27	16	4800	35	22	5357	31	3	300108	59	28	301173	33	8
2902	49	37	4800	35	27	5381	23	18	300109	57	15	301181		2
2905	37	5	4800	43	34	5381	29	9	300109	59	30	301181	12	
2905	49	7	4800	43	43	5403	29	11	300110	57	14	301181	63	3
2905	49	28	4800	45	14	5422	29	14	300110	59	29	301183	49	3
2905-HC	47	7	4800	45	19	5422	33	7	300140	27	22	301241		2
2905-HC	47	9	4800	45	24	5457	33	5	300172	51	25	301241	12	
2918	47	19	4802	35	16	5461	31	14	300207	11		301241	63	2
2921	27	13	4802	43	29	5461	31	19	300207	21		301243		2
2921	29	29	4802	45	9	5527	55	19	300207	59	1	301243	12	
2921	31	27	4802	55	24	5528	53	7	300208	59	2	301243	63	1
2924	47	4	4803	43	38	5529	53	19	300215	39	5	301245	33	12
3001	23	22	4803	53	17	137142	39	28	300216	39	24	301246	33	14
3001	25	22	4803	57	21	137142	39	31	300220	39	25	301247	33	15
3001	27	24	4803	59	36	192087	53	6	300257	57	7	301248	33	17
3018	29	12	4804	35	9	200098	33	23	300291	35	8	301272	47	18
3044	31	21	4805	37	10	200098	55	16	300291	39	4	301274		2
3044	39	30	4805	39	33	200183	53	30	300294	51	24	301274		4
3091	59	14	4805	57	17	200821	47	5	300296-FD	9		301274		5
4009-1	29	25	4805	59	8	201185	59	19	300296-FD	19		301274	12	
4009-1	31	9	4805	59	32	201252	35	17	300296-FD	61	11	301274	14	
4009-1	31	23	4806	29	18	201252	43	30	300297	9		301274	15	
4009-1	47	10	4806	29	43	201252	43	37	300297	19		301274	63	4
4009-1	47	12	4808	51	23	201252	45	8	300297	61	12	301310	10	
4009-1	47	16	4904	53	32	201252	53	18	300299	27	18	301310	20	
4009-1	47	22	4910	37	12	201759	39	20	300301	9		301327	43	71
4009-1	47	24	4910	39	35	202013	35	13	300301	19		301329	23	30
4009-1	49	5	4910	57	19	202013	43	26	300301	61	13	301332	23	24
4009-1	49	49	4910	59	34	202013	45	5	300303	9		301408		5
4009-1	53	14	4911	35	44	202013	53	5	300303	19		301408	15	
4009-1	59	3	4911	43	74	202433	29	19	300303	27	1	301498	35	40
4009-1	59	11	4911	45	61	202433	29	42	300305	11		301597	47	3
4012	39	3	5010	47	17	202433	29	55	300305	21		301599		2
4016	53	2	5053	33	9	202526	39	36	300305	57	1	301599	12	
4100	43	60	5059	29	4	204115	29	31	300306	27	25	301599	47	1
4100	45	41	5077		2	204585	37	11	300318	59	5	301637	23	36
4100	53	29	5077		3	204585	39	34	300365	57	23	301638	23	38
4104	35	35	5077		5	204585	57	18	300365	59	38	301639	23	39
4104	43	65	5077		6	204585	59	9	301048	23	23	301640	33	19
4104	45	49	5077		12	204585	59	33	301118	23	33	301641	23	41
4105	35	24	5077		13	204586	35	21	301138	23	6	301642	23	43
4105	43	40	5077		15	204586	35	26	301139	23	21	301643	23	32
4105	45	21	5077		16	204586	35	36	301143	5		301643	23	37
4106	43	53	5077		23	204586	43	33	301143	7		301749	10	
4106	45	34	5077		29	204586	43	42	301143	15		301749	20	
4107	35	14	5077		31	204586	43	54	301143	17		301749	23	31
4107	43	27	5077		63	204586	43	63	301143	61	2	301751		4

PART NO.	PAGE	REF. NO.	PART NO.	PAGE	REF. NO.	PART NO.	PAGE	REF. NO.	PART NO.	PAGE	REF. NO.	PART NO.	PAGE	REF. NO.
301751	14		303432	8		303729	16		303812	15		306022	29	26
301751	23	35	303432	15		303729	63	8	303812	16		306023	29	28
301753	23	34	303432	18		303738	53	15	303812	63	10	306024	3	
301754	23	44	303432	61	7	303741	53	12	303813	55	11	306024	9	
301886	45	58	303433	6		303742	53	13	303814	55	14	306024	13	
301887	61	24	303433	8		303743	53	10	303815	55	17	306024	19	
301889	61	25	303433	16		303744	53	8	303816	55	18	306024	61	14
301891	61	26	303433	18		303745	53	20	303821	53	31	306024	63	19
301895	47	20	303433	61	9	303746	53	23	303822	3		306025	29	13
301916	4		303448	35	7	303747	2		303822	6		306026	29	2
301916	14		303448	43	36	303747	3		303822	13		306256	63	21
301916	47	13	303448	49	12	303747	4		303822	16		306256	63	29
302098	23	8	303448	49	15	303747	11		303822	49	30	306257	49	36
302098	25	33	303448	49	40	303747	12		303823	2		306258	49	38
302197	23	10	303448	49	43	303747	13		303823	5		306260	3	
302198	51	26	303448	55	13	303747	14		303823	12		306260	13	
302199	33	22	303448	55	23	303747	21		303823	15		306260	63	23
303010	7		303448	57	22	303747	55	1	303823	49	21	306262	49	46
303010	8		303448	59	37	303748	55	25	303824	53	11	306263	3	
303010	9		303499	35	43	303750	55	8	303825	55	21	306263	9	
303010	10		303499	43	73	303751	55	9	303846	51	22	306263	13	
303010	17		303499	45	60	303752	55	10	303847	55	7	306263	19	
303010	18		303500	35	42	303758	2		303848	25	37	306263	29	1
303010	19		303500	43	72	303758	12		303849	25	29	306583-FD	29	45
303010	20		303500	45	59	303758	63	11	303852	25	34	306584-FD	29	46
303010	37	7	303510	7		303764	2		303853	25	23	306585	29	47
303013	25	17	303510	8		303764	12		303854	2		306586	29	49
303020	23	2	303510	9		303764	63	5	303854	3		306587	29	50
303020	25	31	303510	10		303772	2		303854	5		306588	3	
303021	25	32	303510	17		303772	12		303854	6		306588	13	
303026	35	15	303510	18		303772	25	35	303854	8		306588	63	25
303026	43	28	303510	19		303774	3		303854	10		306588-FD	9	
303026	45	7	303510	20		303774	13		303854	12		306588-FD	19	
303063	23	12	303510	37	1	303774	25	24	303854	13		306588-FD	61	18
303063	25	12	303511	37	2	303776	25	25	303854	15		306589	3	
303063	27	12	303550	35	20	303777	2		303854	16		306589	9	
303067	23	20	303550	35	25	303777	5		303854	18		306589	13	
303067	25	20	303550	43	32	303777	12		303854	20		306589	19	
303067	27	21	303550	43	41	303777	15		303854	61	6	306589	61	19
303096	23	4	303550	45	12	303777	63	6	303854	63	9	306589	63	26
303096	25	4	303550	45	17	303780	6		303858	53	16	306590	9	
303096	27	4	303550	45	22	303780	8		303865	43	51	306590	19	
303097	23	5	303677	49	2	303780	16		303865	45	32	306590	29	44
303097	25	5	303677	49	22	303780	18		303973	2		306612	3	
303097	27	5	303678	49	18	303780	25	1	303973	3		306612	13	
303097	29	51	303678	49	31	303781	5		303973	5		306612	49	34
303130	8		303708	2		303781	8		303973	12		306613	61	28
303130	18		303708	3		303781	15		303973	13		306613-FD	9	
303130	61	23	303708	5		303781	18		303973	15		306613-FD	19	
303131	23	3	303708	6		303781	25	30	303997	51	27	306617	3	
303131	25	3	303708	12		303782	3		304028	53	24	306617	13	
303141	25	2	303708	13		303782	6		304029	53	26	306617	63	28
303337	49	24	303708	15		303782	13		304030	53	28	306618	3	
303353	49	26	303708	16		303782	16		304031	53	3	306618	13	
303421	63	13	303708	63	15	303782	49	17	304044	25	10	306618	63	24
303424-FD	2		303713	2		303783	2		304064	25	8	306619	31	30
303424-FD	3		303713	3		303783	5		304071	10		306620	29	56
303424-FD	5		303713	4		303783	12		304071	20		306685	29	40
303424-FD	6		303713	12		303783	15		304071	25	38	306712	9	
303424-FD	12		303713	13		303783	49	1	304072	25	39	306712	19	
303424-FD	13		303713	14		303800	8		304073	25	40	306712	31	1
303424-FD	15		303713	53	1	303800	18		304076	25	41	306713-FD	31	2
303424-FD	16		303714	2		303800	61	5	304077	61	27	306714	31	4
303424-FD	63	12	303714	3		303802	5		306001	29	20	306715	31	7
303424-HD	2		303714	5		303802	8		306002	29	5	306716-FD	31	10
303424-HD	3		303714	6		303802	15		306003	29	30	306717	31	11
303424-HD	5		303714	12		303802	18		306004	29	32	306718-FD	31	12
303424-HD	6		303714	13		303802	61	4	306004	31	18	306719	31	13
303424-HD	12		303714	15		303808	3		306005	29	33	306720	31	15
303424-HD	13		303714	16		303808	13		306006	29	3	306721	31	17
303424-HD	15		303714	63	14	303808	63	17	306008A	29	8	306722	31	24
303424-HD	16		303721	43	61	303810	3		306010	29	15	306723	31	26
303424-HD	63	7	303721	45	42	303810	13		306011	29	16	306724	FD	9
303426	25	21	303729	2		303810	63	18	306012	29	10	306724-FD	19	
303431	6		303729	3		303812	2		306013	29	35	306724-FD	61	15
303431	8		303729	5		303812	3		306014	29	38	306725-FD	9	
303431	16		303729	6		303812	5		306015	29	37	306725-FD	19	
303431	18		303729	6		303812	12		306016	29	24	306725-FD	61	21
303431	61	8	303729	13		303812	12		306016	31	27	306726-FD	9	
303432	5		303729	15		303812	13		306021	29	21	306726-FD	19	

PART NO.	PAGE	REF. NO.	PART NO.	PAGE	REF. NO.	PART NO.	PAGE	REF. NO.	PART NO.	PAGE	REF. NO.	PART NO.	PAGE	REF. NO.
306726-FD	61	17	601043	39	21	742136	35	31	760081	5		811032	12	
306727-FD	9		601046	53	35	742137	35	32	760081	6		811032	13	
306727-FD	19		601046	55	5	742138	35	55	760081	12		811032	14	
306727-FD	61	22	601046	57	10	742139	35	54	760081	13		811032	15	
306735	31	28	601047	57	9	742143	35	52	760081	15		811032	16	
306929	3		601049	39	16	742144	35	56	760081	16		811032	17	
306929	13		601049	59	16	742148	53	38	760081	41	1	811032	18	
306969	63	20	605003	7		742183	45	53	760082	2		811032	19	
307072-FD	3		605003	8		742184	45	54	760082	3		811032	20	
307072-FD	13		605003	9		742185	45	55	760082	5		811032	33	1
307072-FD	63	31	605003	10		742186	45	57	760082	6		811033	33	2
500001	51	2	605003	17		742187	45	51	760082	12		850004	43	48
500002	51	4	605003	18		742188	45	66	760082	13		850004	45	29
500003	51	8	605003	19		745022	35	37	760082	15		850007	43	49
500004	51	10	605003	20		745030	43	56	760082	16		850007	45	30
500005	11		605003	39	1	745030	45	37	760082	41	7			
500005	21		608000	53	36	745031	43	59	760083	2				
500005	51	1	608000	55	6	745031	45	40	760083	3				
500006	11		608000	57	11	745032	43	64	760083	5				
500006	21		608001	51	15	745032A	45	48	760083	6				
500006	51	3	608002	39	17	745039	43	52	760083	12				
500007	11		608002	59	17	745050	45	45	760083	13				
500007	21		701004	43	47	745056	45	33	760083	15				
500007	51	7	701004	45	28	748002	43	76	760083	16				
500008	11		701008	35	29	748002	45	63	760083	41	11			
500008	21		701008	43	45	748003	37	4	760084	2				
500008	51	9	701008	45	26	748004	35	46	760084	3				
500009	51	11	708004	7		748004	43	77	760084	5				
500010	51	12	708004	8		748004	45	64	760084	6				
500011	51	5	708004	9		748005	47	8	760084	12				
500012	51	6	708004	10		748005	47	15	760084	13				
500013	51	13	708004	17		748005	47	21	760084	15				
500014	51	14	708004	18		748005	49	4	760084	16				
500015	51	16	708004	19		748005	49	6	760084	41	18			
500016	51	17	708004	20		748005	49	13	760129	45	4			
500017	51	18	708004	37	6	748005	49	41	760132	4				
500018	51	19	712001	49	35	748006	47	25	760132	14				
513015	29	52	712003	49	16	748006	49	27	760132	45	1			
513016	7		712006	47	2	748006	49	48	771001	35	41			
513016	8		712008	47	14	748007	43	75	771003	35	28			
513016	9		716002	49	44	748007	45	62	771003	43	44			
513016	10		716007	47	11	748011	35	38	771003	45	25			
513016	17		716007	47	23	748011	43	57	771004	35	33			
513016	18		716007	49	8	748011	45	38	771005	53	39			
513016	19		716008	49	23	748014	45	46	772002	35	23			
513016	20		742044	35	45	750008	43	50	772002	43	39			
513016	33	10	742044	43	78	750008	45	31	772002	45	20			
513017	33	11	742044	45	65	752005	29	36	783001	35	30			
513044	10		742067	37	3	752024	35	34	783001	43	46			
513044	20		742075	35	2	760040	7		783001	45	27			
513044	33	20	742075	41	9	760040	8		785001	43	55			
513045	33	21	742075	45	2	760040	9		785001	45	36			
531001	39	23	742076	35	10	760040	10		790001	35	5			
532004	39	7	742076	41	5	760040	17		790001	41	3			
555001	39	6	742077	41	15	760040	18		790002	41	13			
595001	39	2	742078	41	16	760040	19		790003	35	49			
600006A	55	2	742085	35	51	760040	20		790003	41	20			
600006A	57	12	742085	41	4	760040	35	1	791005	41	2			
600006A	59	22	742086	41	14	760041	7		791005	45	10			
600007A	59	23	742087	35	48	760041	8		791006	41	12			
600012	39	11	742087	41	22	760041	9		791008	35	18			
600013	39	9	742088	41	23	760041	10		791008	45	15			
600014	39	10	742094	43	79	760041	17		791013	41	19			
600015	39	22	742095	43	80	760041	18		791022	35	50			
600016	39	14	742095	45	67	760041	19		811006	29	17			
600050	53	34	742099	51	28	760041	20		811024	53	22			
600050	55	4	742100	53	37	760041	35	4	811025	4				
600050	57	8	742102	43	67	760042	35	12	811025	10				
600051	53	33	742103	43	68	760044	7		811025	14				
601001	59	15	742103	45	52	760044	8		811025	20				
601002	39	19	742104	43	69	760044	9		811025	33	18			
601003	55	3	742105	43	70	760044	10		811032	2				
601003	57	13	742105	45	56	760044	17		811032	3				
601020	39	18	742106	41	8	760044	18		811032	4				
601030	39	13	742106	45	3	760044	19		811032	5				
601033	29	53	742107	35	53	760044	20		811032	6				
601038	39	15	742107	41	21	760044	35	47	811032	7				
601040	39	12	742117	41	81	760077	43	25	811032	8				
601042	33	13	742118	41	82	760081	2		811032	9				
601042	39	8	742119	41	83	760081	3		811032	10				

■ PEGASUS
SEWING MACHINE MFG.
CO., LTD.®

