

-4 SERIES

**MODELS: 503-4. 504-4. 505-4. 512-4. 514-4.
515-4. 516-4.**

INTRODUCTION

- This parts catalog covers the -4 series machine manufactured November, 1990.
- On pages 2~73, each mechanism is arranged on facing pages, the first page containing the illustrations and the second page containing the data of the individual parts.
The number given to each illustration is the REF. NO. on the parts list.
- Gauge parts construction charts/gauge parts lists.
Gauge parts are used in some machine types and sewing gauges only. Pages 74~123 contain the gauge parts construction charts in order to know the illustrations and the combinations of the parts, and pages 124~132 contain the gauge parts lists to obtain the data at a glance.
- A part number index is attached to the back of this catalog for convenience.
- When placing orders for parts from this catalog, use ONLY THE PART NUMBER.
- This parts catalog is applicable to your machine and is subject to change without notification.

TABLE OF CONTENTS

Page

Machine bed frame	2-3
Cover(1)~(3)	4-9
Crankshaft drive mechanism(1)~(3)	10-15
Needle drive mechanism(1)~(3)	16-21
Upper looper drive mechanism(1),(2)	22-25
Lower looper drive mechanism	26-27
Chainstitch looper drive mechanism(1),(2)	28-31
Feed mechanism(1)~(3)	32-37
Knife drive mechanism	38-39
Presser foot mechanism(1)~(3)	40-45
Lubrication mechanism	46-47
H.R. device	48-49
Attachment for piping(1)~(3)	50-55
Attachment for tape	56-57
Attachment for shirring	58-59
Attachment	60-61
Attachment for shirring (option)	62-63
Attachment (option)	64-65
Parts for semi-submerged installation	66-67
Thread stand	68-69
Accessories	70-71
Piping foot/Others	72-73
Gauge parts construction charts	74-123
Gauge parts lists	124-132
Needle size and upper looper (Spreader)	133
List of main feed dog complete	133
Part number index	134-138

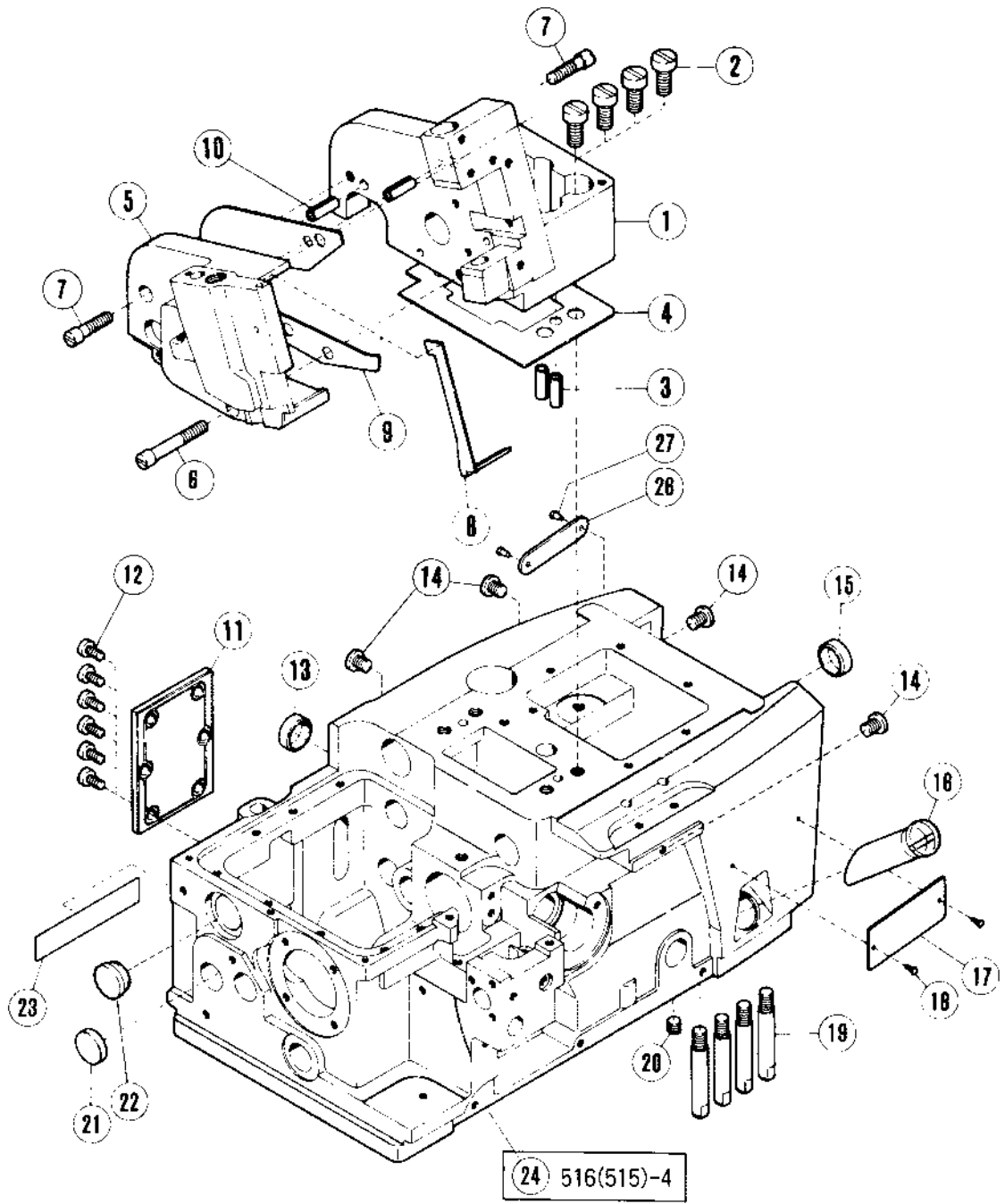

504-4, 503-4, 505-4,
512-4, 514-4

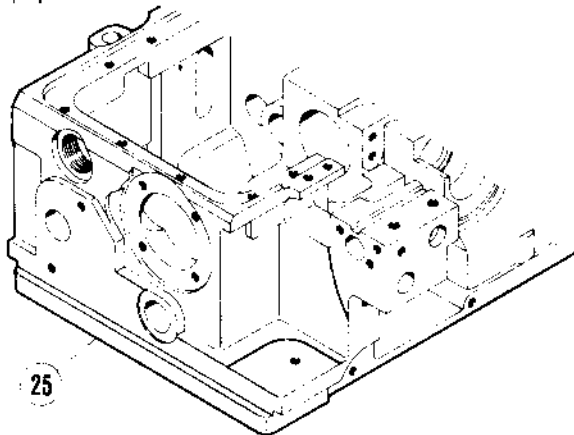

MACHINE BED FRAME

REF. NO.	PART NO.	NAME	QT.	MEMO
1	208602-FD	MACHINE ARM (RIGHT)	1	
2	5078	SCREW	4	
3	201002	PIN	2	
4	204251	GASKET	1	
5	208603-FD	MACHINE ARM (LEFT)	1	
6	5237	SCREW	1	
7	5163	SCREW	2	
8	208434	OIL SHIELD	1	
9	208169A	GASKET	1	
10	201002	PIN	2	
11	210005	COVER PLATE	1	
12	5117	SCREW	6	
13	210003	PLUG	1	
14	5332A	SCREW	4	
15	204828	PLUG	1	
16	204003	OIL SIGHT GAUGE	1	
17	212280A	TYPE PLATE	1	
18	210679	PIN	2	
19	204006	BED PIN	4	
20	2022	SCREW	1	
21	210003	PLUG	1	
22	240162	PLUG	1	
23	202526	NAME PLATE	1	
24	208600AFD	MACHINE BED	1	
25	208601AFD	MACHINE BED	1	
26	230047A	SERIAL NUMBER PLATE	1	
27	210679	PIN	2	

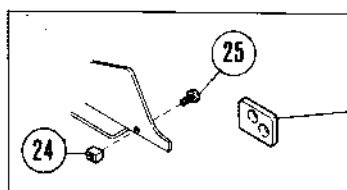
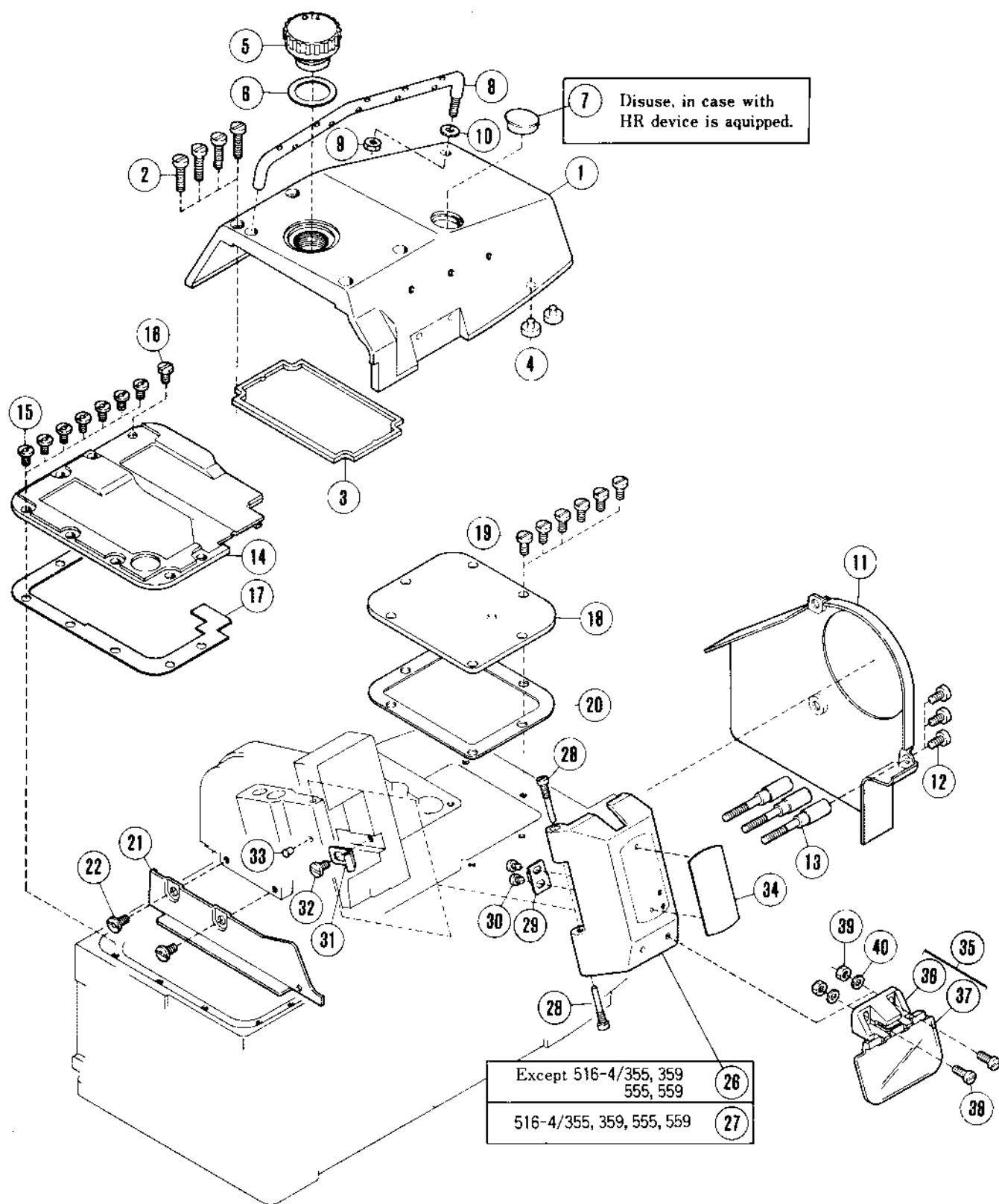

29 Use in case HR device is not equipped.

24 25 For Needle Plates without the chaining land.

COVER (1)

REF. NO.	PART NO.	NAME	QT.	MEMO
1	208299-HD	TOP COVER	1	
2	5152	SCREW	4	
3	208481	O RING	1	
4	208482	CUSHION RUBBER	2	
5	206457	OIL SIGHT WINDOW	1	
6	206682	GASKET	1	
7	208339	PLUG	1	
8	208802	THREAD GUIDE BAR	1	
9	3044	NUT	1	
10	200098	WASHER	1	
11	205216A	BELT COVER	1	
12	5091	SCREW	3	
13	205217	SCREW	3	
14	208919	BED PLATE COMPLETE (LEFT)	1	
15	4009-1	SCREW	7	
16	5482	SCREW	1	
17	208921	GASKET	1	
18	208341	BED COVER PLATE (RIGHT)	1	
19	5117	SCREW	6	
20	208342	GASKET	1	
21	204848A	FABRIC GUARD	1	
22	4009-1	SCREW	2	
23	204646	SPACER PLATE	1	
24	204681	SPACER	1	
25	2922	SCREW	1	
26	208023AHD	NEEDLE BAR COVER	1	
27	209163-HD	NEEDLE BAR COVER	1	
28	202653	SCREW	2	
29	202689	FLAT SPRING	1	
30	1234	SCREW	2	
31	204223	FLAT SPRING	1	
32	4009-1	SCREW	1	
33	198192	CUSHION RUBBER	1	
34	208725	NAME PLATE	1	
35	208747	EYE GUARD COMPLETE	1	
36	208744	EYE GUARD BRACKET COMPLETE	1	
37	205685	EYE GUARD	1	
38	1175-3	SCREW	2	
39	3091	NUT	2	
40	137906	WASHER	2	

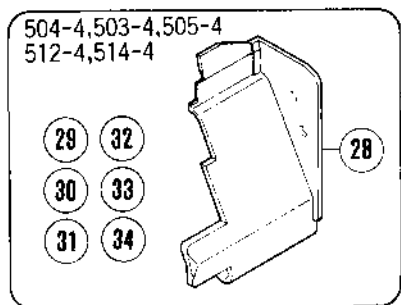
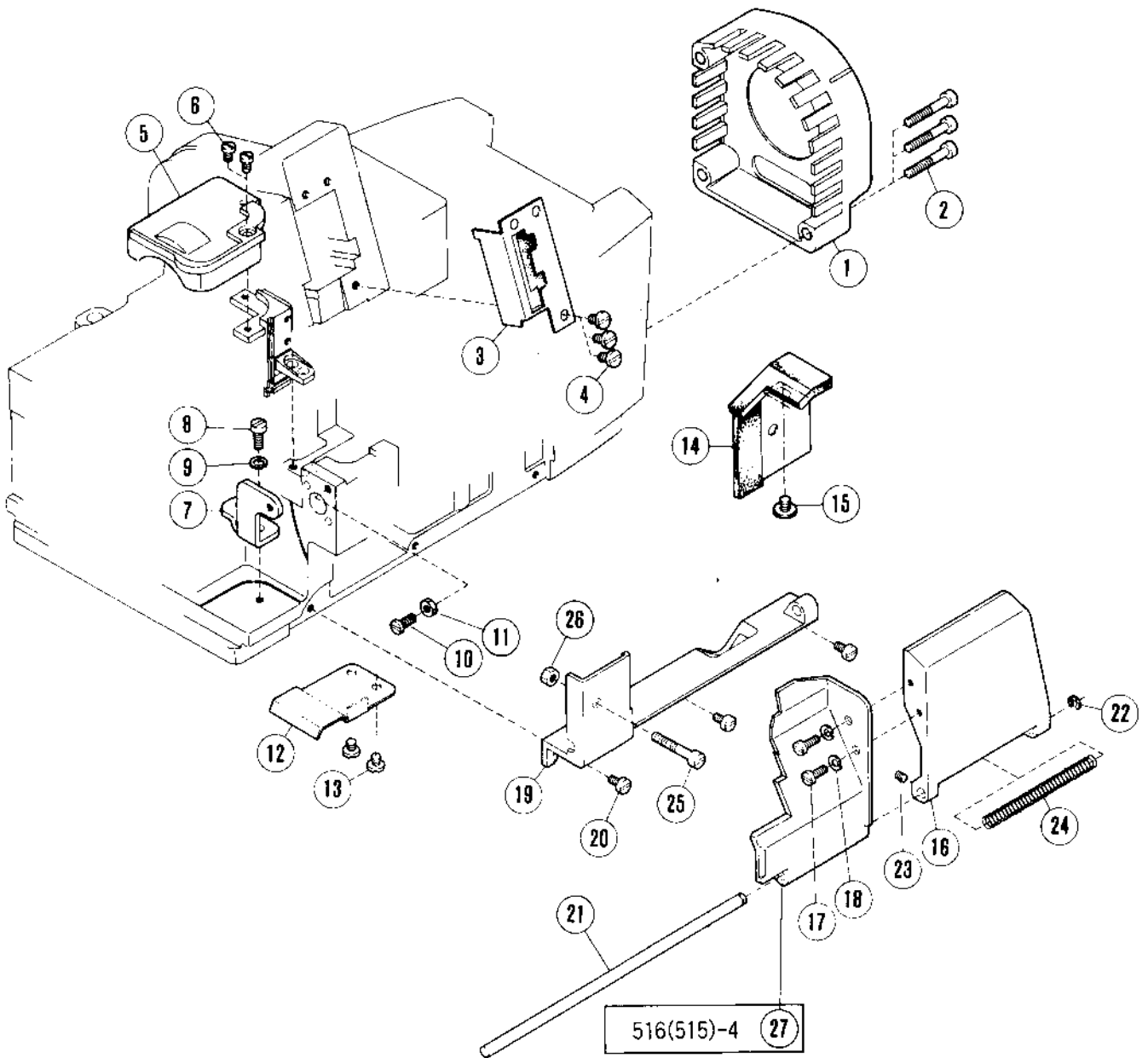

	504-4, 503-4, 505-4 [1-needle] (Except 504-4/65)	504-4/65	514-4, 512-4 [2-needle] (NG=1.5mm)	514-4, 512-4 [2-needle] (NG=2.5-3.5mm)	514-4, 512-4 [2-needle] (NG=2.0mm)
HR DEVICE					
YES	29	31	29	33	29
NO	28	30	28	32	34

※ 33 Should be used for 512-5/53, 512-4/57 (NG=2.0mm)

COVER (2)

REF. NO.	PART NO.	NAME	QT.	MEMO
1	204650A	COVER	1	
2	5094	SCREW	3	
3	208430	FACE PLATE COMPLETE	1	
4	4009-1	SCREW	3	
5	208945	COVER/FEED ECCENTRIC	1	
6	5328	SCREW	2	
7	204868	SPACER	1	
8	2902	SCREW	1	
9	202286	SPRING WASHER	1	
10	5002	SCREW	1	
11	3044	NUT	1	
12	210007	FEED BAR COVER	1	
13	2905	SCREW	2	
14	208604	OIL SHIELD COMPLETE	1	
15	5147	SCREW	1	
16	208001-FD	FRONT COVER (RIGHT)	1	
17	1175-3	SCREW	2	
18	200821	WASHER	2	
19	208008-FD	HINGE/FRONT COVER	1	
20	1216	SCREW	3	
21	208009	PIN	1	
22	200555	RING	1	
23	5146	SCREW	2	
24	208010	SPRING	1	
25	5094	SCREW	1	
26	5137	NUT	1	
27	208401	FRONT COVER (LEFT)	1	
28	208003	FRONT COVER (LEFT)	1	
29	208004	FRONT COVER (LEFT)	1	
30	208005	FRONT COVER (LEFT)	1	
31	208006	FRONT COVER (LEFT)	1	
32	208058	FRONT COVER (LEFT)	1	
33	208056	FRONT COVER (LEFT)	1	
34	209285	FRONT COVER (LEFT)	1	

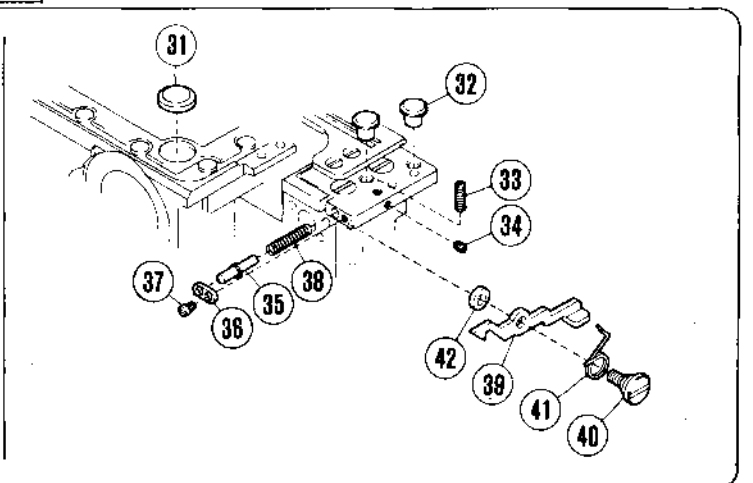
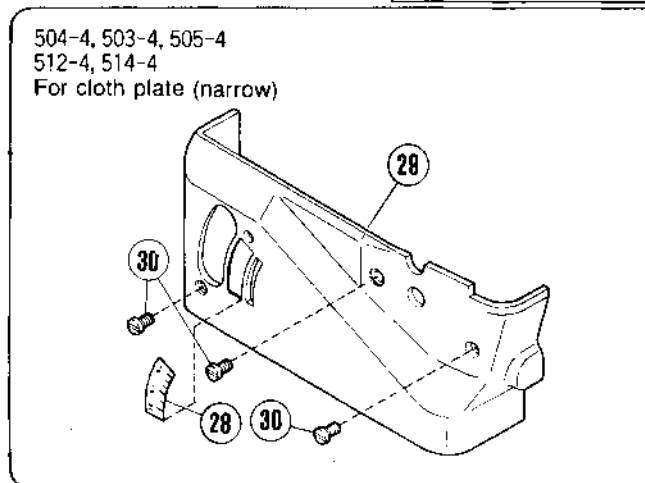
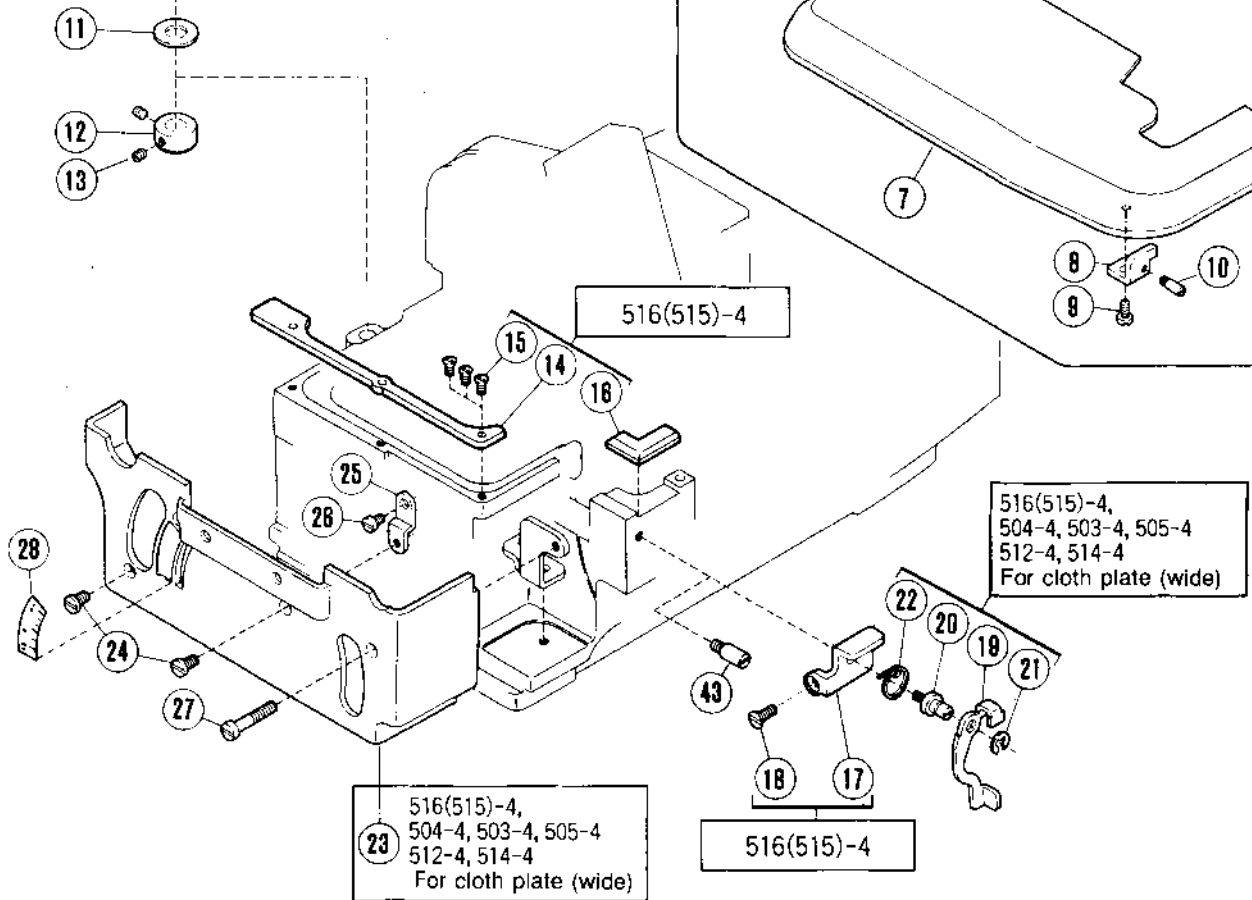
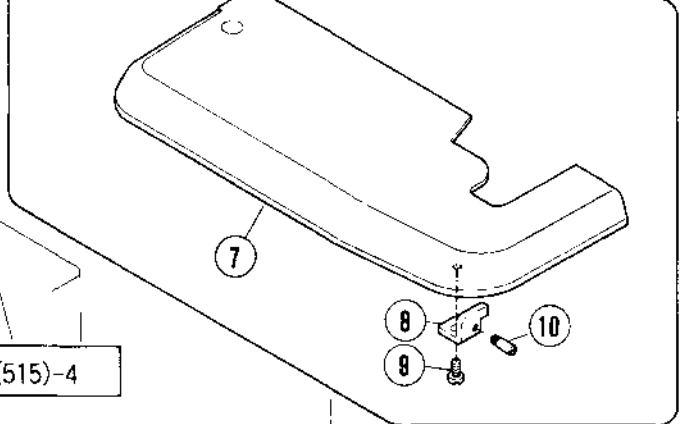
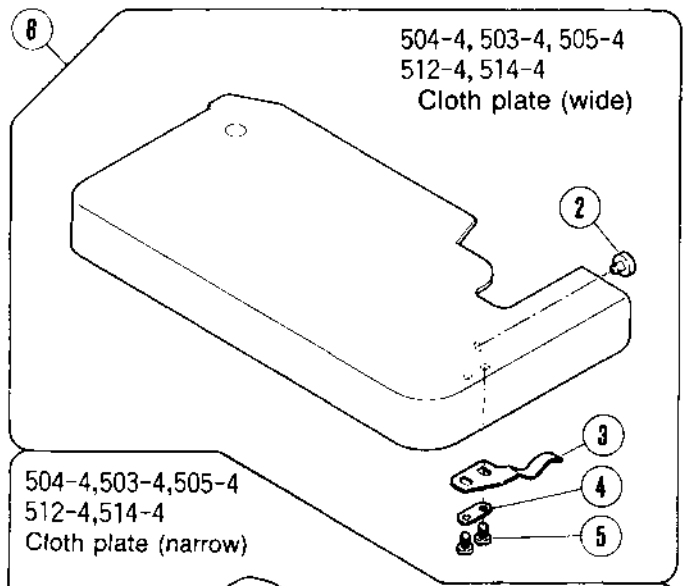
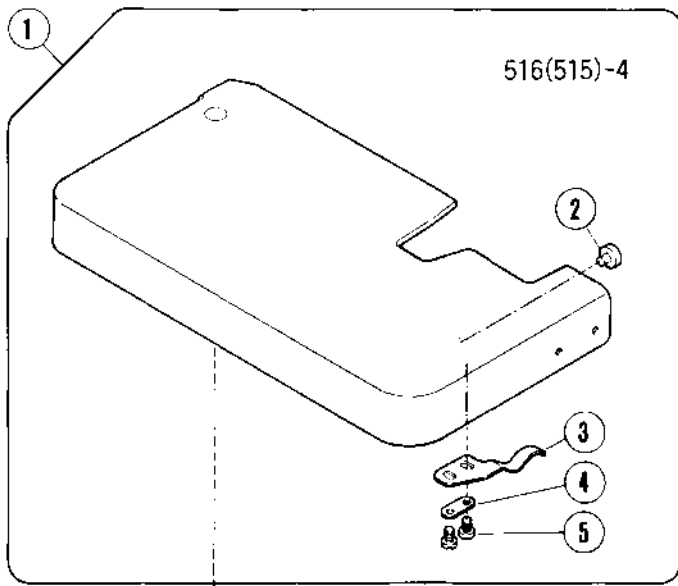

COVER (3)

REF. NO.	PART NO.	NAME	QT.	MEMO
1	208610	CLOTH PLATE COMPLETE	1	
2	210025	CUSHION	1	
3	204218	FLAT SPRING	1	
4	200162A	WASHER	1	
5	1216	SCREW	2	
6	208612	CLOTH PLATE COMPLETE	1	
7	208611	CLOTH PLATE COMPLETE	1	
8	204744	BRACKET	1	
9	1202	SCREW	1	
10	204743	SCREW	1	
11	202576	WASHER	1	
12	201139	COLLAR	1	
13	1457	SCREW	2	
14	204242	RUBBER PLUG	1	
15	5022	SCREW	3	
16	204243	RUBBER PLUG	1	
17	208741	STOPPER	1	
18	1732	SCREW	1	
19	208737	LEVER	1	
20	208738	PIN	1	
21	201629	RING	1	
22	208740	SPRING	1	
23	204865AFA	SIDE COVER	1	
24	5091	SCREW	1	
25	204867	SPACER	1	
26	5113	SCREW	1	
27	5182	SCREW	1	
28	209405	INDICATION PLATE	1	
29	204857A-FA	SIDE COVER COMPLETE	1	
30	5091	SCREW	3	
31	204827	RUBBER PLUG	1	
32	204749	RUBBER PLUG	1	
33	1435	SCREW	1	
34	1459	SCREW	1	
35	204746	PIN	1	
36	204747	GUIDE	1	
37	5053	SCREW	1	
38	204748	SPRING	1	
39	204742	LATCH	1	
40	5362	SCREW	1	
41	204745	SPRING	1	
42	208245	WASHER	1	
43	5232	SCREW	1	

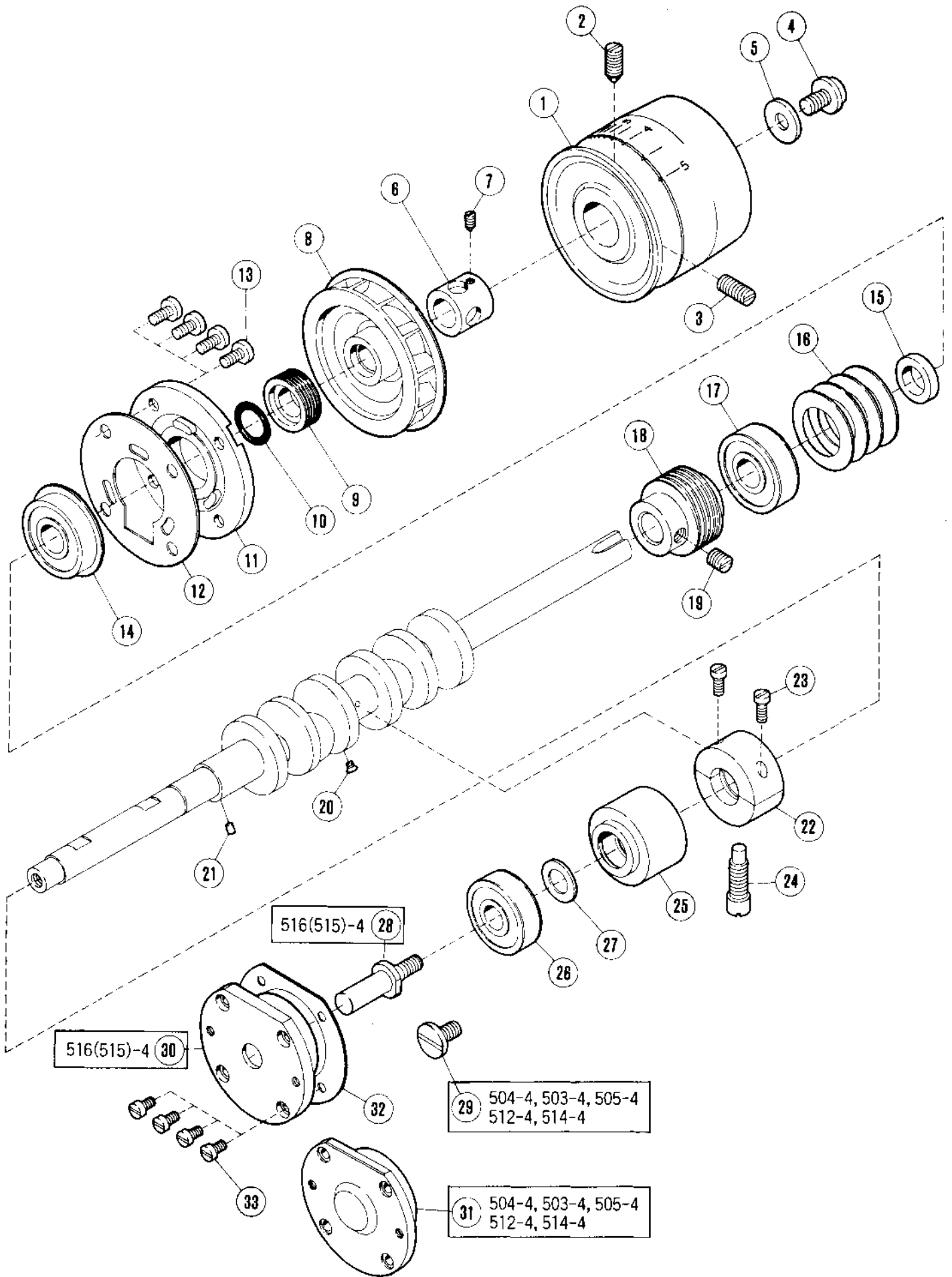

CRANKSHAFT DRIVE MECHANISM (1)

REF. NO.	PART NO.	NAME	QT.	MEMO
1	208932-HD	MACHINE PULLEY	1	
2	5080	SCREW	1	
3	5081	SCREW	1	
4	5549	SCREW	1	
5	204023	WASHER	1	
6	204026	SPACER	1	
7	5267	SCREW	1	
8	204198	COOLING FAN	1	
9	208476	OIL SEAL COLLAR	1	
10	208272	O RING	1	
11	208477	PLATE	1	
12	204022	GASKET	1	
13	5117	SCREW	4	
14	204020A	BUSHING	1	
15	204019A	SPACER	1	
16	204018	SPRING	4	
17	201523A	BALL BEARING	1	
18	204186A	WORM	1	
19	2022	SCREW	1	
20	5304	SCREW	1	
21	207358	OIL FELT	1	
22	204016	BUSHING	1	
23	1170-1	SCREW	2	
24	5240	SCREW	1	
25	204014	BUSHING	1	
26	204010	BUSHING	1	
27	240102	WASHER	1	
28	204873	CRANK SHAFT EXTENSION	1	
29	5361	SCREW	1	
30	204881	HOUSING	1	
31	204737	HOUSING	1	
32	204319	GASKET	1	
33	1175-2	SCREW	4	

1	3 ~ 16	516(515)-4 except the following models.
2	3 ~ 15 • 17	516(515)-4/86, 87, 88, 89, 355, 359, 555, 559

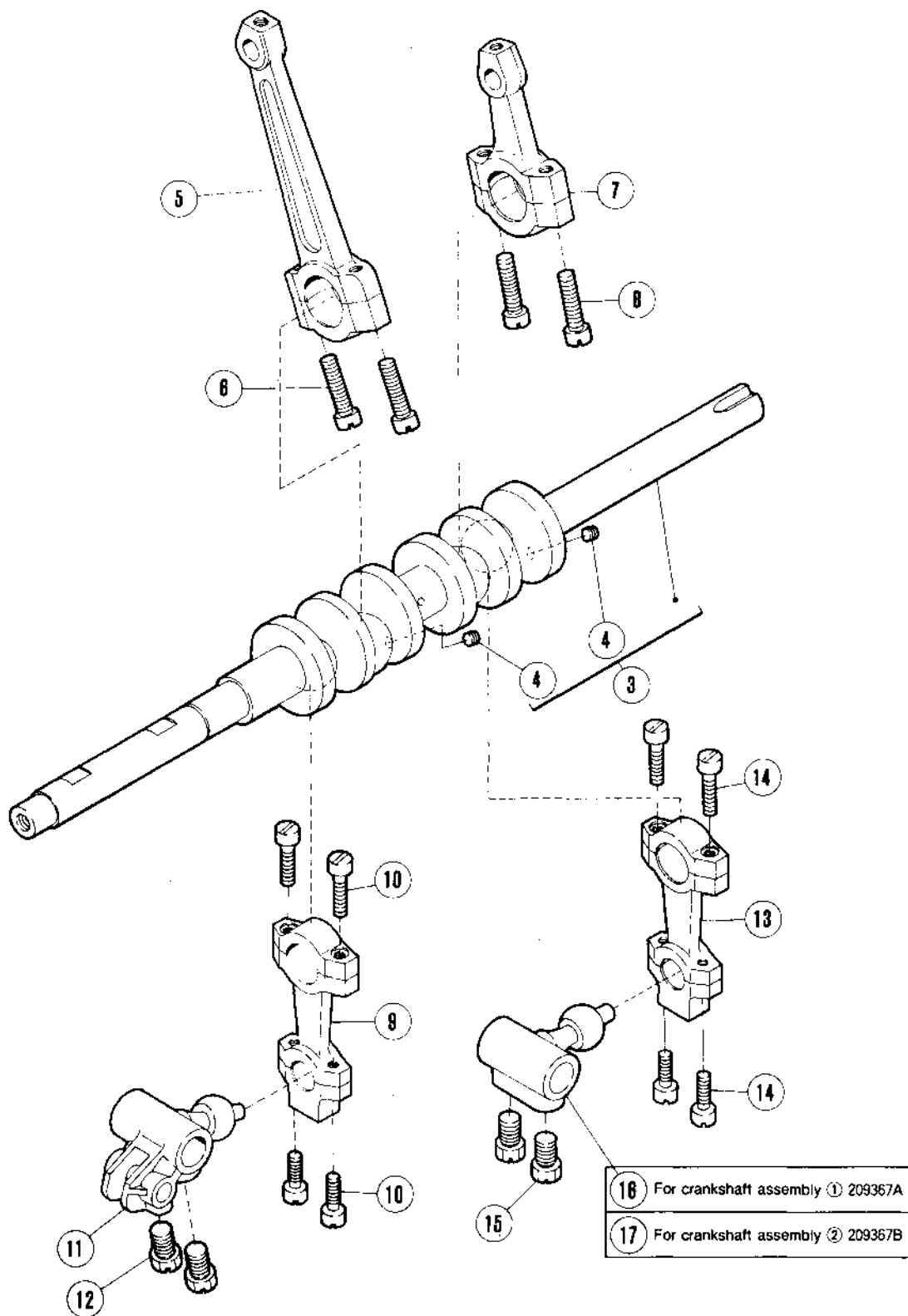

CRANKSHAFT DRIVE MECHANISM (2)

REF. NO.	PART NO.	NAME	QT.	MEMO
1	209367A	CRANKSHAFT ASSEMBLY	1	
2	209367B	CRANKSHAFT ASSEMBLY	1	
3	208951	CRANKSHAFT	1	
4	1459	SCREW	2	
5	204029	CONNECTION	1	
6	5233	SCREW	2	
7	204145A	DRIVE CONNECTION/UPPER KNIFE	1	
8	5233	SCREW	2	
9	208346	CONNECTION	1	
10	5376	SCREW	4	
11	208192	CRANK/LOWER LOOPER	1	
12	2022-4	SCREW	2	
13	208346	CONNECTION	1	
14	5376	SCREW	4	
15	2022-4	SCREW	2	
16	204048A	CRANK	1	
17	204788	CRANK/LOWER LOOPER	1	

1	4 ~ 16 • 18
2	4 ~ 15 • 17 • 18
3	4 ~ 15 • 17 • 19

- ① • 504-4,503-4,505-4 (except 504-4/65)
- ② • 514-4,512-4 (except 514-4/18,18S1,18S2,18S4,18S5
514-4/67,73.)
• 504-4/65 (SW=3.0~6.0mm)
- ③ • 514-4/18,18S1,18S2,18S4,18S5
514-4/67,73
• 504-4/65 (SW=7.0~8.0mm)

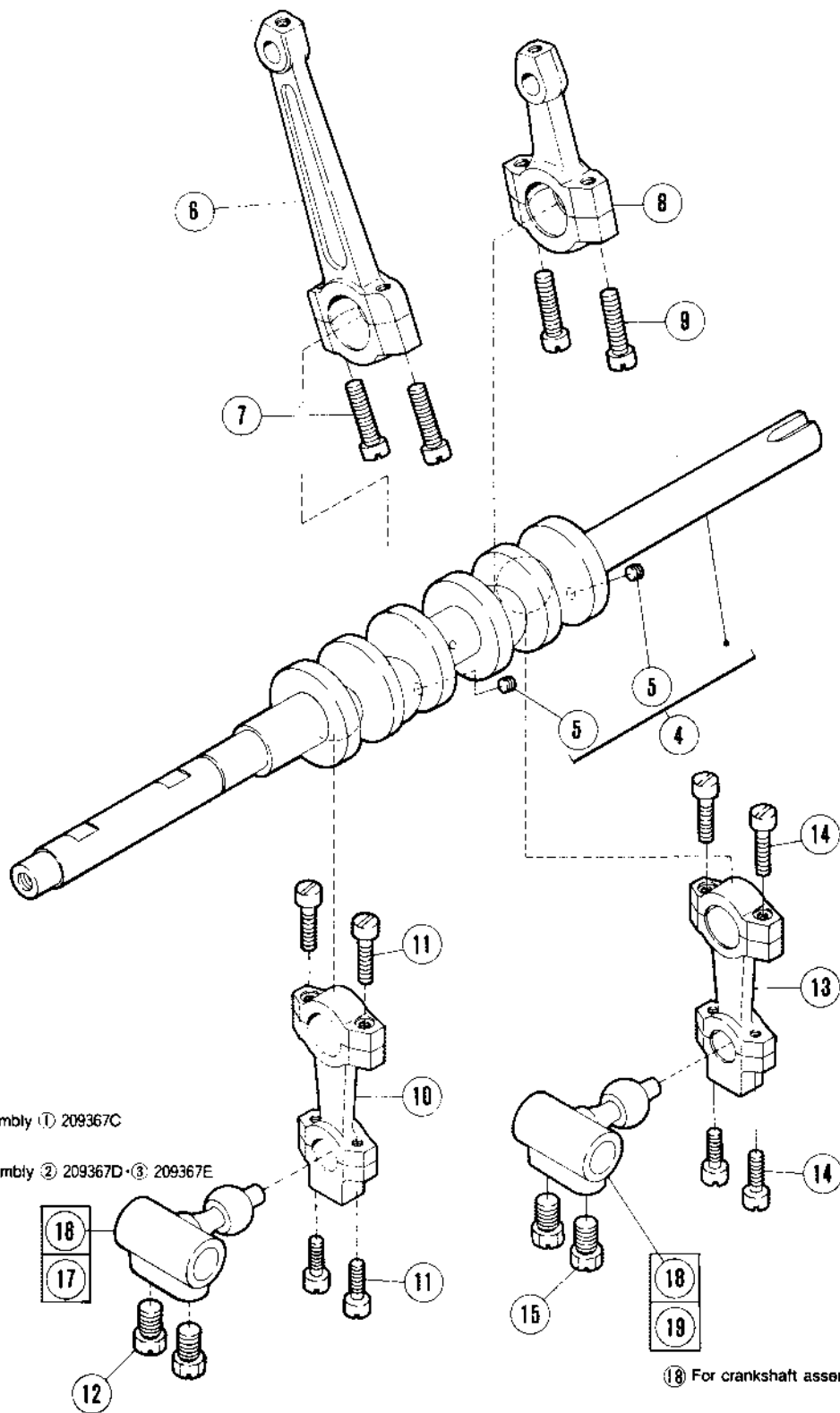

⑬ For crankshaft assembly ① 209367C

⑭ For crankshaft assembly ② 209367D • ③ 209367E

⑮ For crankshaft assembly ① 209367C, ② 209367D

⑯ For crankshaft assembly ③ 209367E

CRANKSHAFT DRIVE MECHANISM (3)

REF. NO.	PART NO.	NAME	QT.	MEMO
1	209367C	CRANKSHAFT ASSEMBLY	1	
2	209367D	CRANKSHAFT ASSEMBLY	1	
3	209367E	CRANKSHAFT ASSEMBLY	1	
4	208951	CRANKSHAFT	1	
5	1459	SCREW	2	
6	204029	CONNECTION	1	
7	5233	SCREW	2	
8	204145A	DRIVE CONNECTION/UPPER KNIFE	1	
9	5233	SCREW	2	
10	208346	CONNECTION	1	
11	5376	SCREW	4	
12	2022-4	SCREW	2	
13	208346	CONNECTION	1	
14	5376	SCREW	4	
15	2022-4	SCREW	2	
16	204787	CRANK/LOWER LOOPER	1	
17	204788	CRANK/LOWER LOOPER	1	
18	204048A	CRANK	1	
19	204788	CRANK/LOWER LOOPER	1	

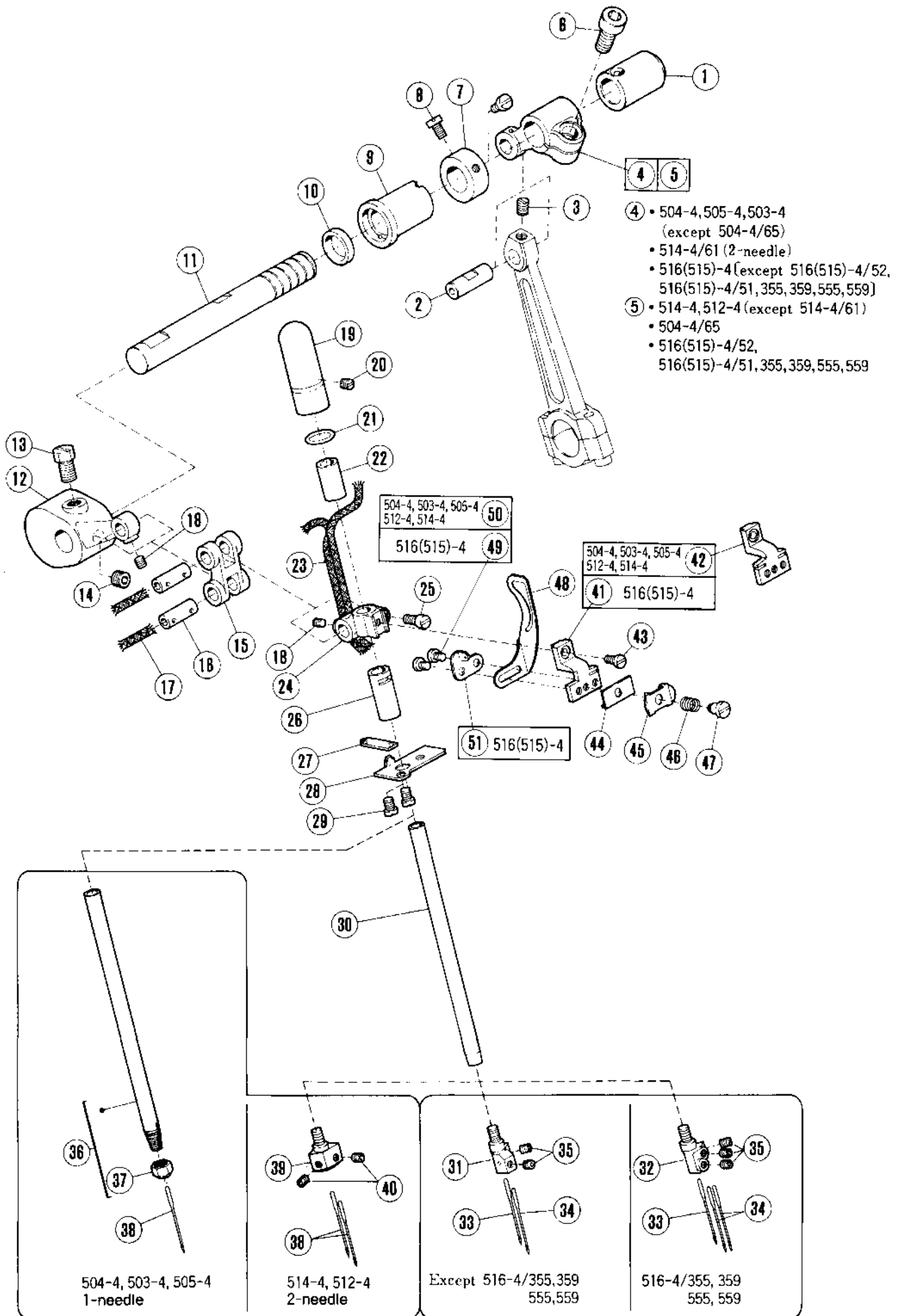

NEEDLE DRIVE MECHANISM (1)

PLEASE NOTE : 「×××××」 is one of the gauge parts.
So please refer to pages 74~132 and
confirm the correct parts.

REF. NO.	PART NO.	NAME	QT.	MEMO
1	208249	BUSHING	1	
2	205495	PIN	1	
3	5234	SCREW	1	
4	201360B	CRANK	1	
5	201441B	CRANK	1	
6	5381	SCREW	1	
7	201117	COLLAR	1	
8	5328	SCREW	2	
9	208248	BUSHING	1	
10	208250	OIL SEAL	1	
11	208247	SHAFT	1	
12	208424	CRANK/NEEDLE BAR	1	
13	2022-4	SCREW	1	
14	5312	SCREW	1	
15	208425	LINK/NEEDLE BAR DRIVE	1	
16	200654	PIN	2	
17	202176	OIL WICK	2	
18	5292	SCREW	2	
19	208621	CAP	1	
20	1457	SCREW	1	
21	200030	O RING	1	
22	204625A	BUSHING	1	
23	212186	OIL WICK	1	
24	208427	NEEDLE BAR CLAMP	1	
25	1170-3	SCREW	1	
26	204627A	BUSHING	1	
27	208617	OIL FELT	1	
28	208616	DUST SHIELD	1	
29	5053	SCREW	2	
30	208903	NEEDLE BAR	1	
31	XXXXXX	NEEDLE HOLDER	1	
32	XXXXXX	NEEDLE HOLDER	1	
33	DCX27	NEEDLE	1	
34	DCX27	NEEDLE		
35	5292	SCREW		
36	204623	NEEDLE BAR COMPLETE	1	
37	3119	NUT	1	
38	XXXXXX	NEEDLE		
39	XXXXXX	NEEDLE HOLDER	1	
40	5292	SCREW	2	
41	204706	RETAINER BRACKET	1	
42	202705A	RETAINER BRACKET	1	
43	5359	SCREW	1	
44	202495	GUIDE	1	
45	200041	GUIDE	1	
46	209068	SPRING	1	
47	W09070-2	SCREW	1	
48	202706A	THREAD TAKEUP	1	
49	1186	SCREW	2	
50	5292	SCREW	2	
51	204707	THREAD GUIDE	1	

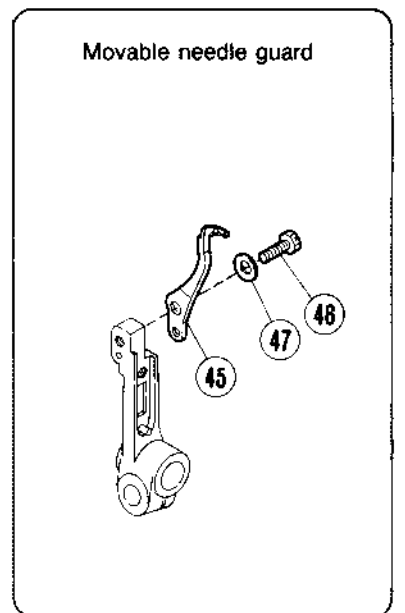
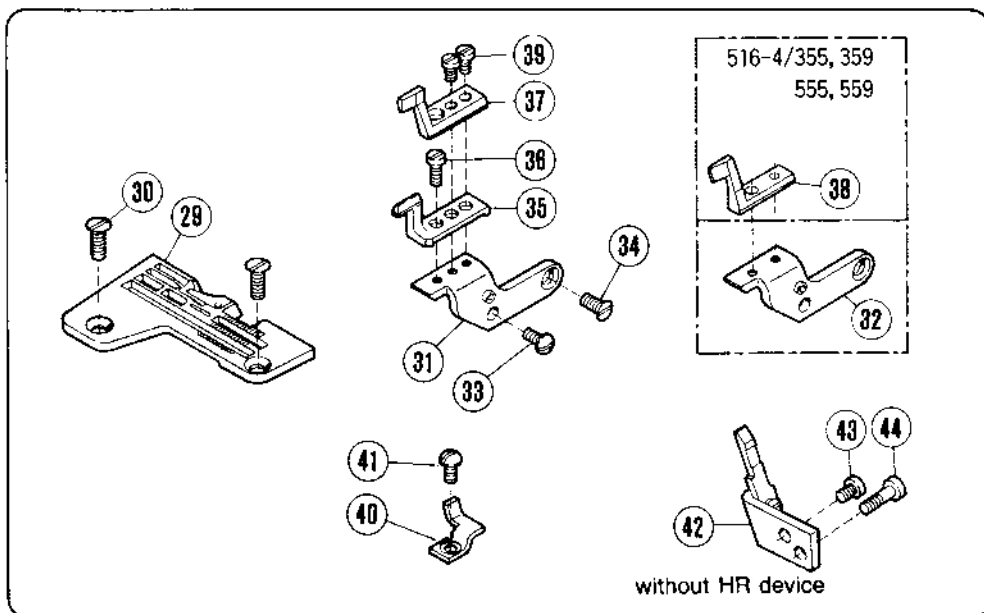
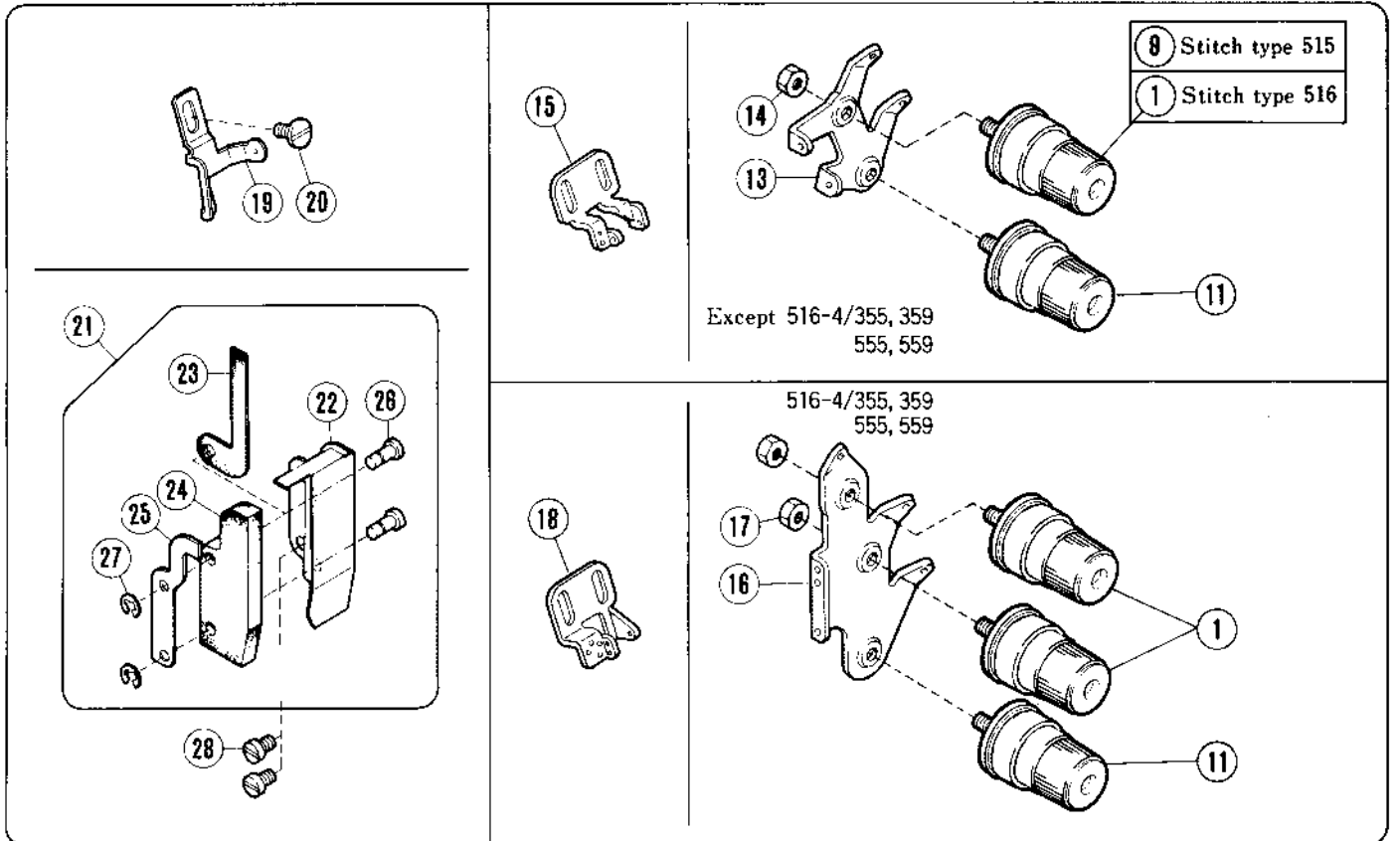
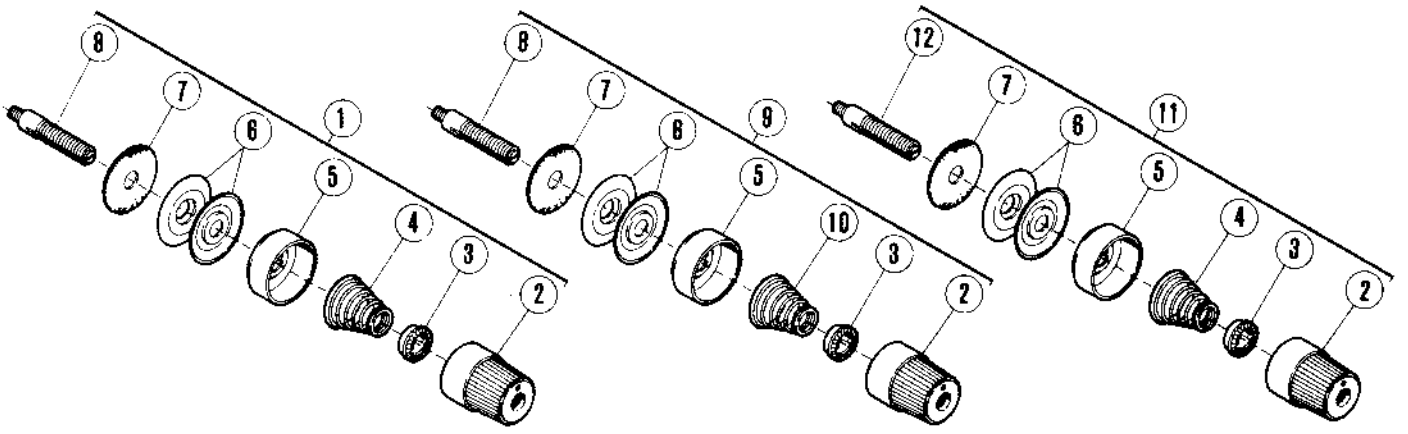

NEEDLE DRIVE MECHANISM (2)

PLEASE NOTE: 「XXXXXX」 is one of the gauge parts.
So please refer to pages 74~132 and confirm the correct parts.

REF. NO.	PART NO.	NAME	QT.	MEMO
1	209174	THREAD TENSION COMPLETE	1	
2	208447	POST NUT	1	
3	208448	SPRING BUSHING	1	
4	201037	SPRING (HEAVY)	1	
5	208450	CUP	1	
6	210319	TENSION DISC	2	
7	208449	FELT	1	
8	5143A	STUD	1	
9	209175	THREAD TENSION COMPLETE	1	
10	201068	SPRING (LIGHT)	1	
11	210529	THREAD TENSION COMPLETE	1	
12	5082A	SCREW STUD	1	
13	208307	TENSION GUIDE	1	
14	5137	NUT	1	
15	208778	THREAD GUIDE	1	
16	209161	TENSION GUIDE	1	
17	5137	NUT	2	
18	208777	THREAD GUIDE	1	
19	208399	THREAD GUIDE	1	
20	4009-1	SCREW	1	
21	208568	NEEDLE BAR LINK COVER COMPLETE	1	
22	208560	NEEDLE BAR LINK COVER	1	
23	208561	OIL FELT	1	
24	208562	OIL FELT	1	
25	208563	OIL FELT PLATE	1	
26	208713	PIN	2	
27	200555	RING	2	
28	5113	SCREW	2	
29	XXXXXX	NEEDLE PLATE	1	
30	1732-HC	SCREW	2	
31	204783	BRACKET	1	
32	209160	BRACKET/NEEDLE GUARD	1	
33	5227	SCREW	1	
34	5107	SCREW	1	
35	204781	NEEDLE GUARD (REAR)	1	
36	5012	SCREW	1	
37	204782	NEEDLE GUARD (FRONT)	1	
38	209159	NEEDLE GUARD (FRONT)	1	
39	5029	SCREW	2	
40	XXXXXX	NEEDLE GUARD	1	
41	5227	SCREW	1	
42	XXXXXX	NEEDLE GUARD	1	
43	1206	SCREW	1	
44	5010	SCREW	1	
45	209009	MOVABLE NEEDLE GUARD	1	
46	5501	SCREW	1	
47	210930	SPRING WASHER	1	

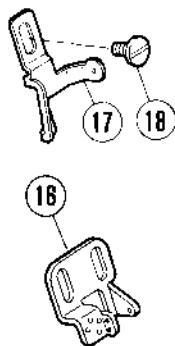
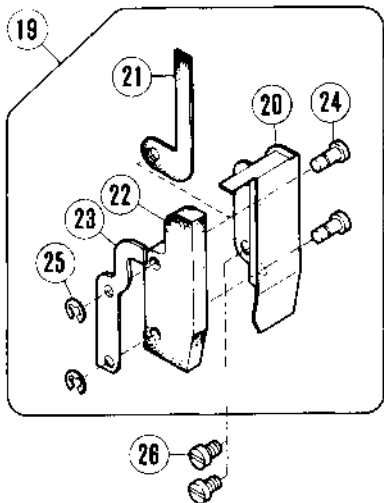
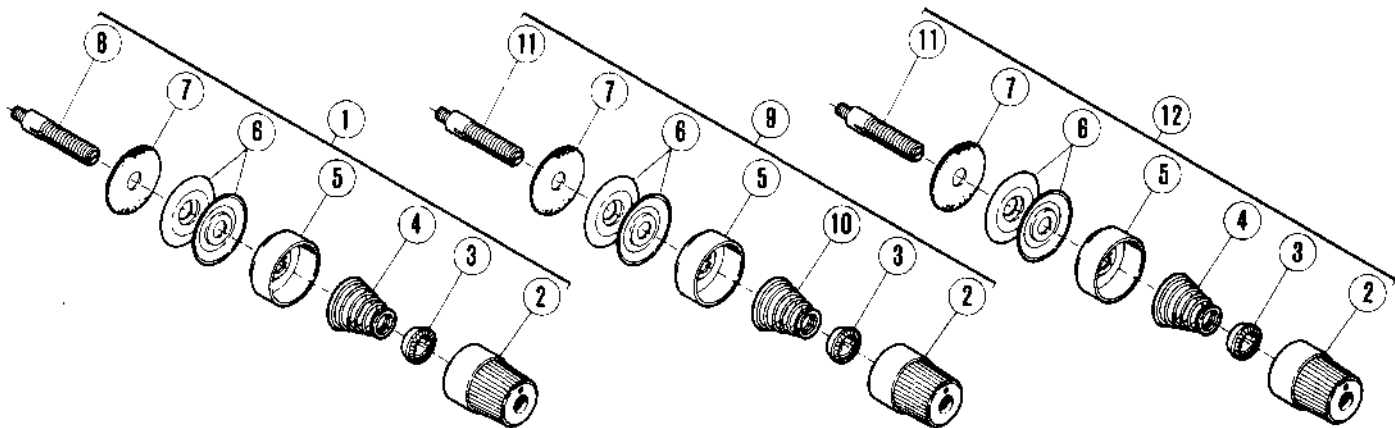

504-4, 503-4, 505-4
1-needle

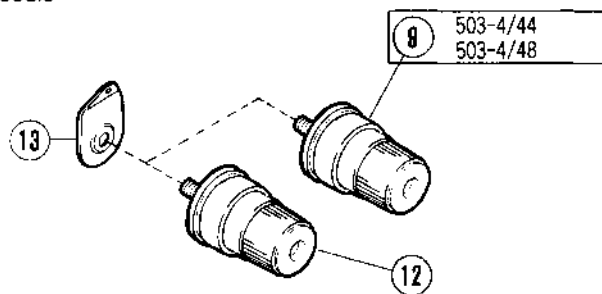

512-4, 514-4
2-needle

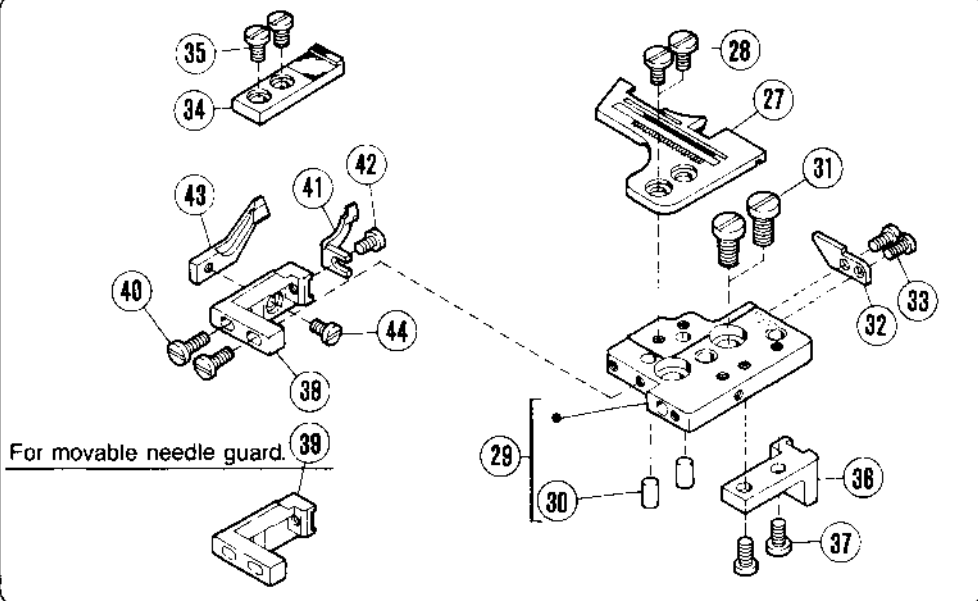
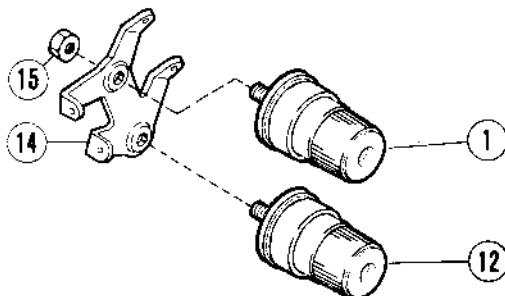

Movable needle guard

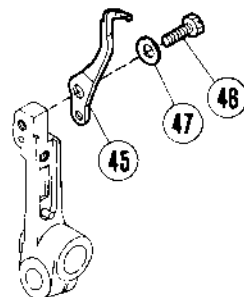

NEEDLE DRIVE MECHANISM (3)

PLEASE NOTE: 「XXXXXX」 is one of the gauge parts.
So please refer to pages 74~132 and confirm the correct parts.

REF. NO.	PART NO.	NAME	QT.	MEMO
1	209174	THREAD TENSION COMPLETE	1	
2	208447	POST NUT	1	
3	208448	SPRING BUSHING	1	
4	201037	SPRING (HEAVY)	1	
5	208450	CUP	1	
6	210319	TENSION DISC	2	
7	208449	FELT	1	
8	5143A	STUD	1	
9	210531	THREAD TENSION COMPLETE	1	
10	201068	SPRING (LIGHT)	1	
11	5082A	SCREW STUD	1	
12	210529	THREAD TENSION COMPLETE	1	
13	202849	TENSION GUIDE	1	
14	208307	TENSION GUIDE	1	
15	5137	NUT	1	
16	208777	THREAD GUIDE	1	
17	208400	THREAD GUIDE	1	
18	4009-1	SCREW	1	
19	208568	NEEDLE BAR LINK COVER COMPLETE	1	
20	208560	NEEDLE BAR LINK COVER	1	
21	208561	OIL FELT	1	
22	208562	OIL FELT	1	
23	208563	OIL FELT PLATE	1	
24	208713	PIN	2	
25	200555	RING	2	
26	5113	SCREW	2	
27	XXXXXX	NEEDLE PLATE	1	
28	4009-1HC	SCREW	2	
29	204750	BRACKET/NEEDLE PLATE	1	
30	204630	PIN	2	
31	5357	SCREW	2	
32	204631	KEY	1	
33	5142	SCREW	1	
34	208935	SUPPORT/NEEDLE PLATE	1	
35	5091	SCREW	1	
36	204762	BASE/EDGE GUIDE	1	
37	5091	SCREW	2	
38	204636	BRACKET/NEEDLE DUARD	1	
39	204636A	BRACKET/NEEDLE DUARD	1	
40	1175-3	SCREW	2	
41	XXXXXX	NEEDLE GUARD (FRONT)	1	
42	1206	SCREW	1	
43	XXXXXX	NEEDLE GUARD (REAR)	1	
44	1206	SCREW	1	
45	209009	MOVABLE NEEDLE GUARD	1	
46	5501	SCREW	1	
47	210930	SPRING WASHER	1	

UPPER LOOPER DRIVE MECHANISM (1)

REF. NO.	PART NO.	NAME	QT.	MEMO
1	201048A	THREAD EYELET	1	
2	201072A	PIPE	1	
3	210531	THREAD TENSION COMPLETE	1	
4	208447	POST NUT	1	
5	208448	SPRING BUSHING	1	
6	201068	SPRING (LIGHT)	1	
7	208450	CUP	1	
8	210319	TENSION DISC	2	
9	208449	FELT	1	
10	5082A	SCREW STUD	1	
11	202849	TENSION GUIDE	1	
12	201074A	GUIDE	1	
13	5546	SCREW	1	
14	202286	SPRING WASHER	1	
15	204052A	OIL SEAL	1	
16	208292	BUSHING	1	
17	210297	BUSHING	1	
18	208429	BUSHING (REAR)	1	
19	204107	WASHER	1	
20	2193	SCREW	1	
21	202286	SPRING WASHER	1	
23	210281	SHAFT/LOWER LOOPER	1	
24	208445	THREAD TAKEUP/UPPER LOOPER	1	
25	208979	THREAD TAKEUP/UPPER LOOPER	1	
26	2902	SCREW	1	
27	204902	AUXILIARY THREAD TAKEUP	1	
28	2921	SCREW	1	
29	202875	WASHER	1	

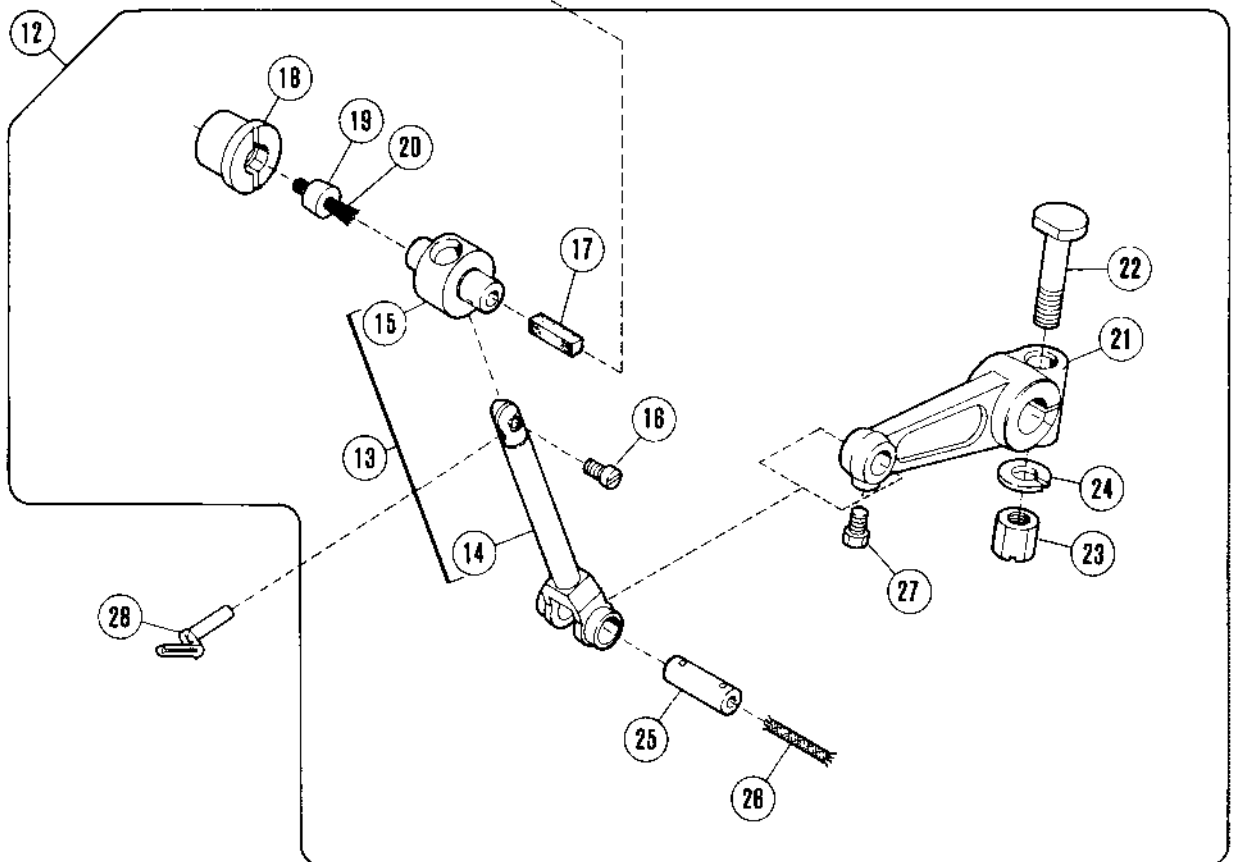
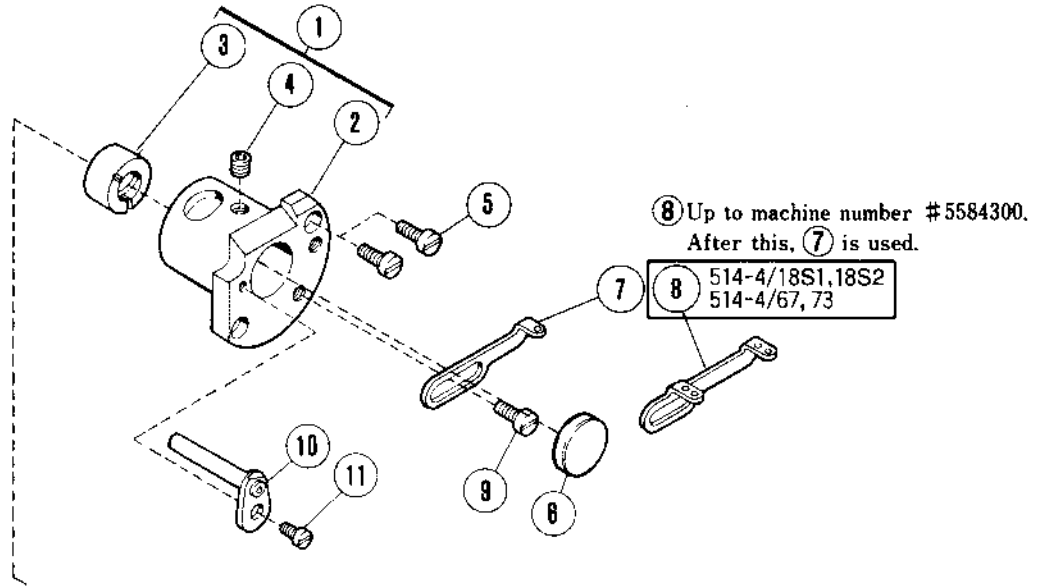

UPPER LOOPER DRIVE MECHANISM (2)

PLEASE NOTE:「×××××」 is one of the gauge parts.
So please refer to pages 74~132 and confirm the correct parts.

REF. NO.	PART NO.	NAME	QT.	MEMO
1	209250	HOUSING ASSEMBLY	1	
2	208937	HOUSING	1	
3	210109	BUSHING	1	
4	5408	SCREW	1	
5	1175-2	SCREW	2	
6	208173	PLUG	1	
7	204905	THREAD GUIDE	1	
8	208980	THREAD GUIDE (LOWER)	1	
9	2905	SCREW	1	
10	204903	THREAD TUBE	1	
11	5012	SCREW	1	
12	209389-91Y	UPPER LOOPER HOLDER	1	
13	208976	UPPER LOOPER HOLDER ASSEMBLY	1	
14	208974	UPPER LOOPER HOLDER	1	
15	210107	GUIDE/UPPER LOOPER HOLDER	1	
16	1998-2	SCREW	1	
17	204274	OIL WICK	2	
18	208938	BUSHING (REAR)	1	
19	208592	CAP	1	
20	202176	OIL WICK	1	
21	204055B	CRANK/UPPER LOOPER	1	
22	5239	SCREW	1	
23	5286	NUT	1	
24	202045	SPRING WASHER	1	
25	208258	PIN	1	
26	202176	OIL WICK	1	
27	5084	SCREW	1	
28	XXXXXX	UPPER LOOPER	1	

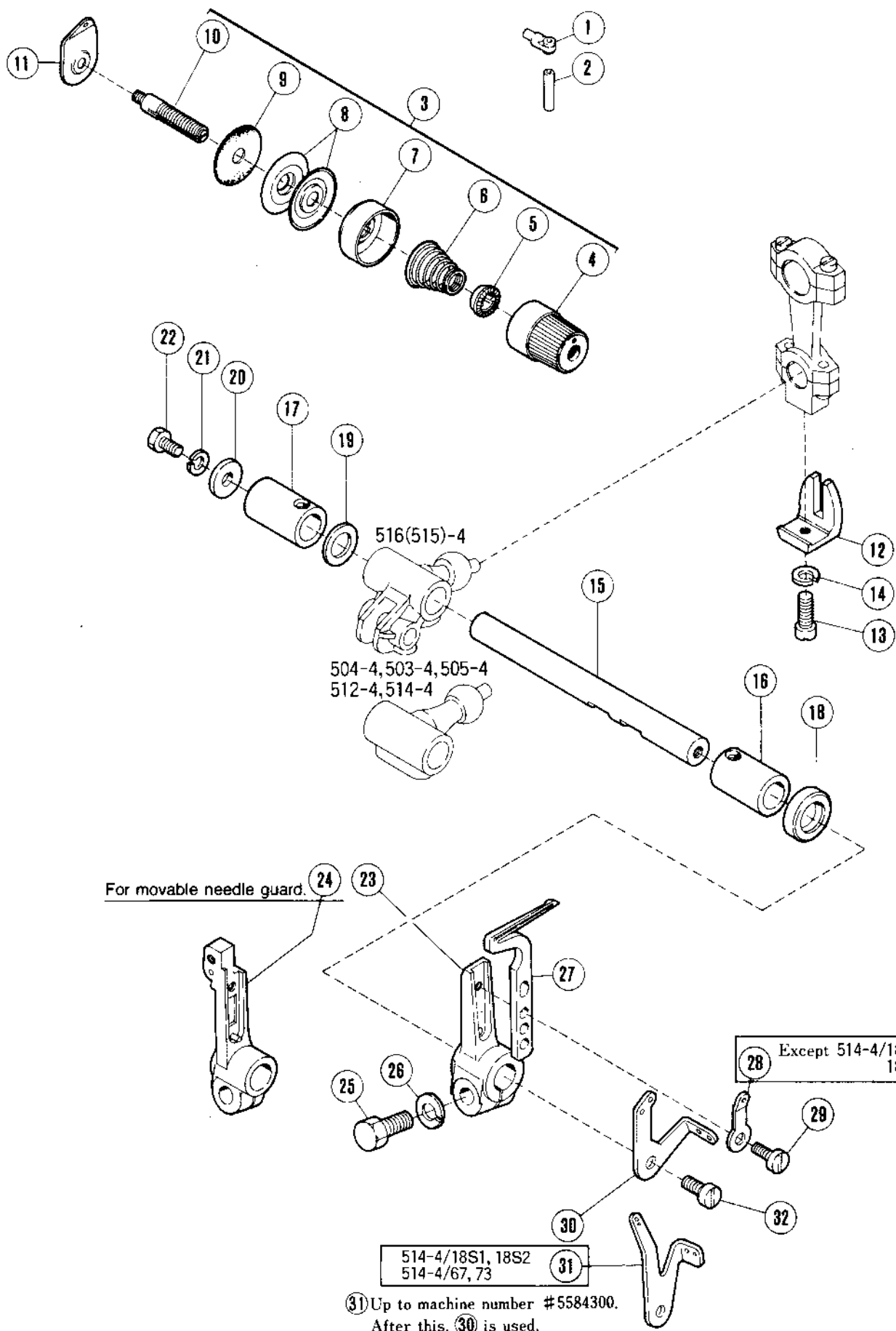

LOWER LOOPER DRIVE MECHANISM

PLEASE NOTE : 「XXXXXX」 is one of the gauge parts.
So please refer to pages 74~132 and confirm the correct parts.

REF. NO.	PART NO.	NAME	QT.	MENO
1	201048A	THREAD EYELET	1	
2	201072A	PIPE	1	
3	210530	THREAD TENSION COMPLETE	1	
4	208447	POST NUT	1	
5	208448	SPRING BUSHING	1	
6	201086	SPRING (MEDIUM)	1	
7	208450	CUP	1	
8	210319	TENSION DISC	2	
9	208449	FELT	1	
10	5082A	SCREW STUD	1	
11	202849	TENSION GUIDE	1	
12	201074A	GUIDE	1	
13	5546	SCREW	1	
14	202286	SPRING WASHER	1	
15	210281	SHAFT/LOWER LOOPER	1	
16	210124	BUSHING	1	
17	210125	BUSHING	1	
18	210586	OIL SEAL	1	
19	240102	WASHER	1	
20	204107	WASHER	1	
21	202286	SPRING WASHER	1	
22	2193	SCREW	1	
23	204664	LOWER LOOPER HOLDER	1	
24	209007	LOWER LOOPER LEVER	1	
25	5284	SCREW	1	
26	204293	SPRING WASHER	1	
27	XXXXXX	LOWER LOOPER	1	
28	210353	THREAD GUIDE	1	
29	1175-3	SCREW	1	
30	204901	THREAD TAKEUP	1	
31	208981	THREAD TAKEUP/LOWER LOOPER	1	
32	2902	SCREW	1	

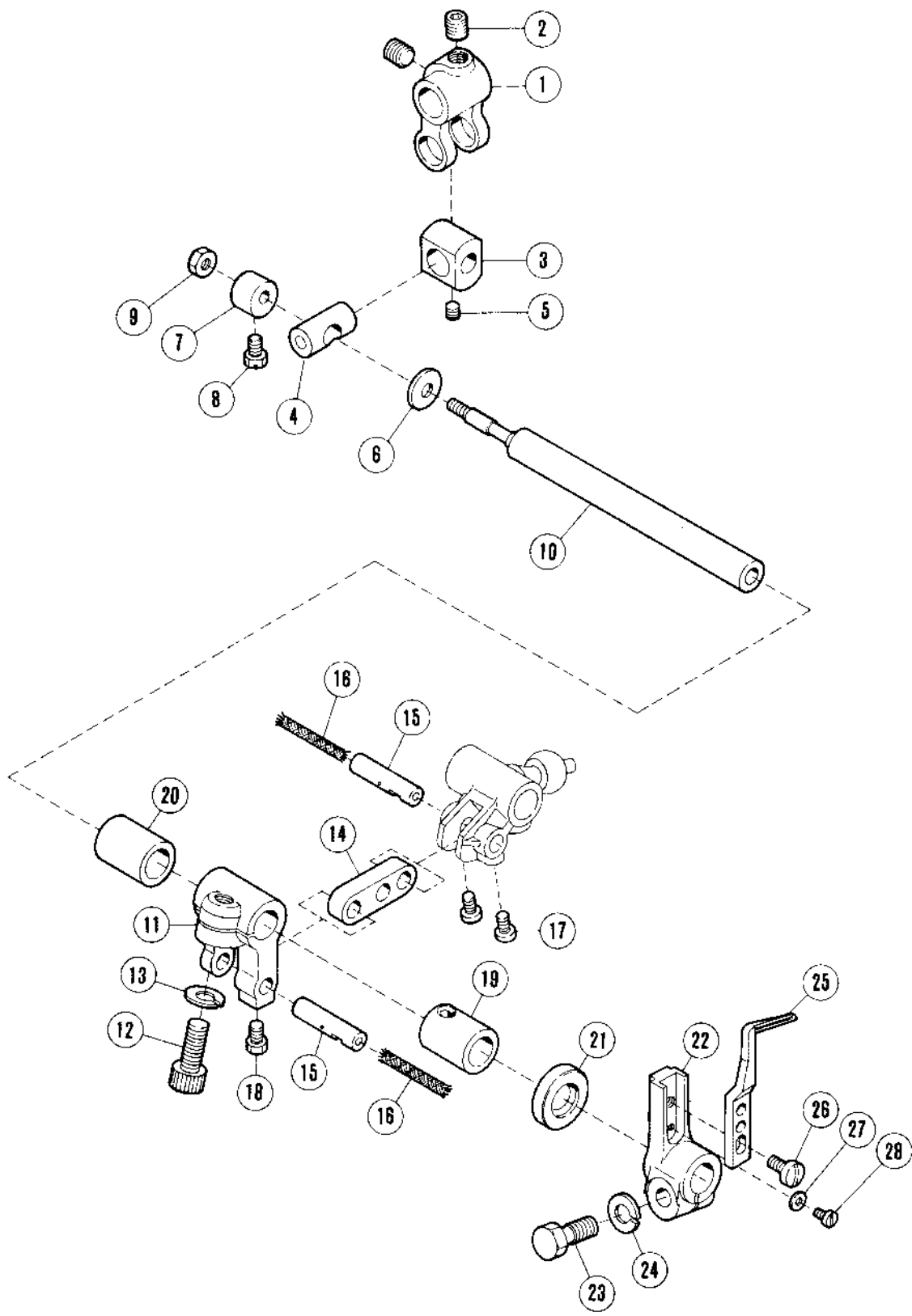

CHAINSTITCH LOOPER DRIVE MECHANISM (1)

PLEASE NOTE:「×××××」 is one of the gauge parts.
So please refer to pages 74~132 and
confirm the correct parts.

REF. NO.	PART NO.	NAME	QT.	MEMO
1	208025	LINK/LOOPER AVOIDING	1	
2	5385	SCREW	2	
3	208027	BLOCK	1	
4	208026	PIN	1	
5	5292	SCREW	1	
6	208028	WASHER	1	
7	208029	COLLAR	1	
8	5084	SCREW	1	
9	4802	NUT	1	
10	208196	SHAFT/LOOPER DRIVE	1	
11	210294	CRANK/LOOPER DRIVE	1	
12	5457	SCREW	1	
13	204293	SPRING WASHER	1	
14	208194	LINK/LOOPER DRIVE	1	
15	208195	PIN	2	
16	202176	OIL WICK	2	
17	5328	SCREW	2	
18	5084	SCREW	1	
19	210296	BUSHING	1	
20	210297	BUSHING	1	
21	210586	OIL SEAL	1	
22	204093	LEVER	1	
23	5284	SCREW	1	
24	204293	SPRING WASHER	1	
25	XXXXXX	LOOPER	1	
26	1189	SCREW	1	
27	204172	WASHER	1	
28	2922	SCREW	1	

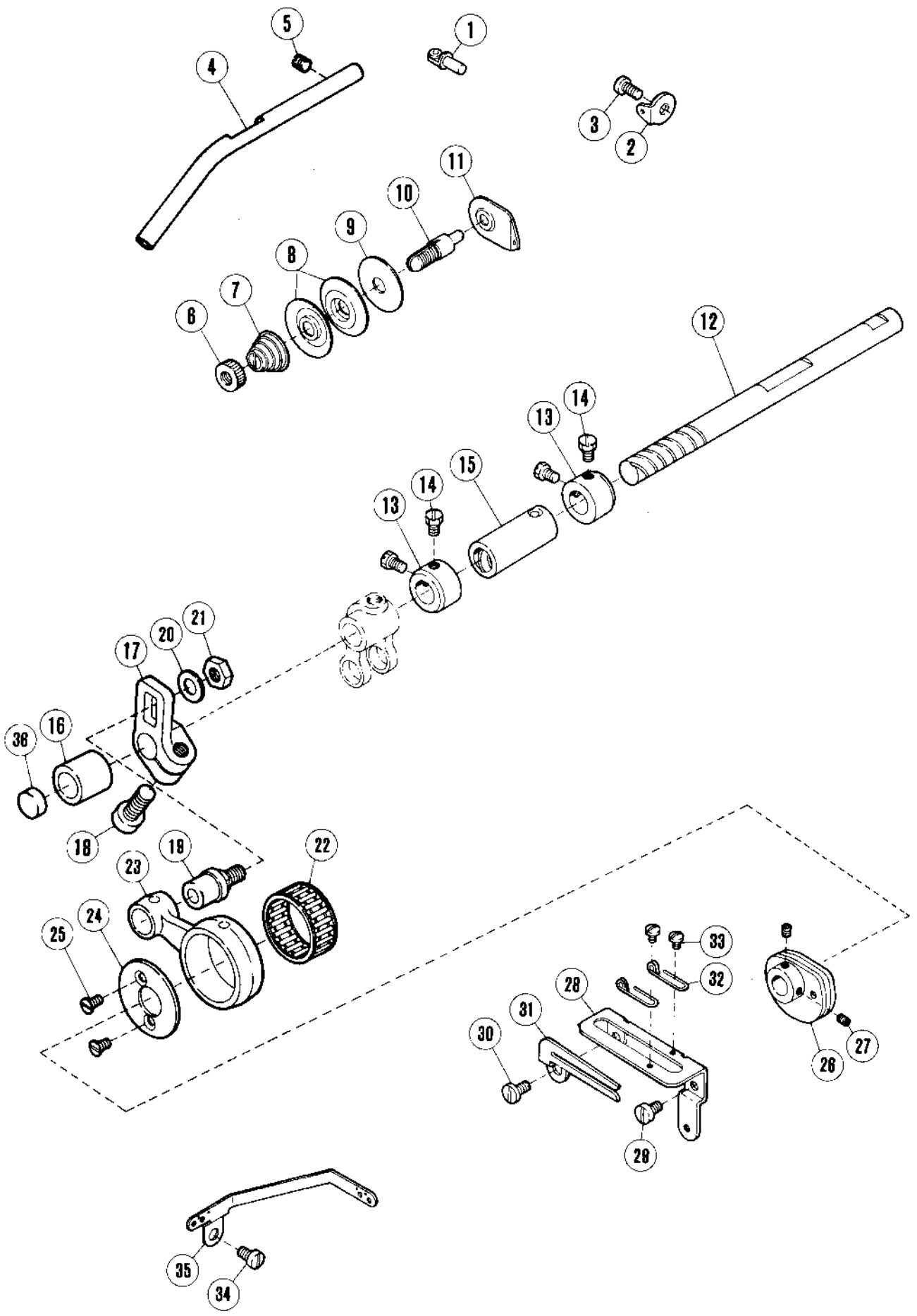

CHAINSTITCH LOOPER DRIVE MECHANISM (2)

REF. NO.	PART NO.	NAME	QT.	MEMO
1	201048A	THREAD EYELET	1	
2	167079	THREAD EYELET	1	
3	5091	SCREW	1	
4	204099	PIPE	1	
5	1457	SCREW	1	
6	3056	NUT	1	
7	167077	SPRING	1	
8	210319	TENSION DISC	2	
9	208449	FELT	1	
10	167072	TENSION POST	1	
11	202849	TENSION GUIDE	1	
12	204874	SHAFT/LOOPER AVOIDING	1	
13	201056	COLLAR	2	
14	5084	SCREW	4	
15	204089	BUSHING	1	
16	210292	BUSHING	1	
17	210287	CRANK/LOOPER AVOIDING	1	
18	5457	SCREW	1	
19	210285	PIN	1	
20	208286	WASHER	1	
21	5455	NUT	1	
22	205015	NEEDLE BEARING	1	
23	210284	CONNECTION/LOOPER AVOIDING	1	
24	210283	COLLAR	1	
25	5259	SCREW	2	
26	204095A	THREAD TAKEUP	1	
27	5292	SCREW	2	
28	204097A	BRACKET	1	
29	5113	SCREW	1	
30	4009-1	SCREW	1	
31	204096	THREAD TAKEUP	1	
32	204324	THREAD EYELET	2	
33	5077	SCREW	2	
34	5113	SCREW	1	
35	208362	THREAD GUIDE	1	
36	205088	PLUG	1	

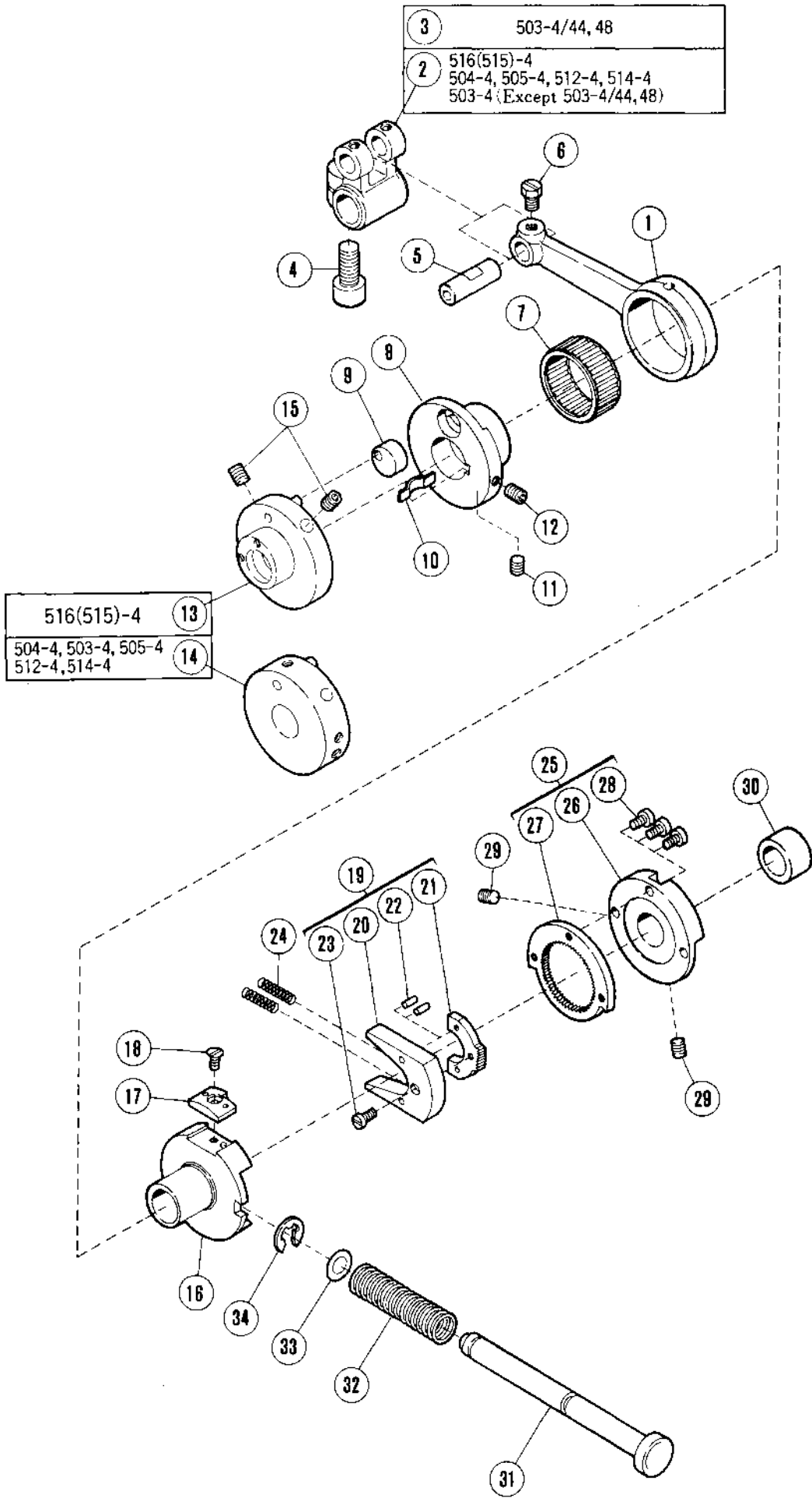

FEED MECHANISM (1)

REF. NO.	PART NO.	NAME	QT.	MEMO
1	204100	CONNECTION	1	
2	204085	CRANK/FEED DRIVE	1	
3	208333	CRANK/FEED DRIVE	1	
4	5381	SCREW	1	
5	205495	PIN	1	
6	5084	SCREW	1	
7	204084	NEEDLE BEARING	1	
8	210127	ECCENTRIC/FEED DRIVE	1	
9	210129	GUIDE/FEED ECCENTRIC	1	
10	210130	FLAT SPRING	1	
11	5292	SCREW	1	
12	5427	SCREW	1	
13	210282A	ECCENTRIC/LOOPER AVOIDING	1	
14	210128A	FEED ECCENTRIC RETAINER	1	
15	5461	SCREW	2	
16	211802A	ECCENTRIC/FEED REGULATING	1	
17	211804	STOPPER	1	
18	5437	SCREW	1	
19	208411	FEED REGULATING RATCHET	1	
20	208413	BRACKET	1	
21	208412	RATCHET	1	
22	206781	PIN	2	
23	5336	SCREW	1	
24	208415	SPRING	2	
25	210136	RATCHET WHEEL COMPLETE	1	
26	211807	BRACKET	1	
27	211806	WHEEL	1	
28	5157	SCREW	3	
29	5461	SCREW	2	
30	208944	SPACER	1	
31	209304	PUSH BUTTON	1	
32	208421	SPRING	1	
33	208949	O RING	1	
34	202522	RING	1	

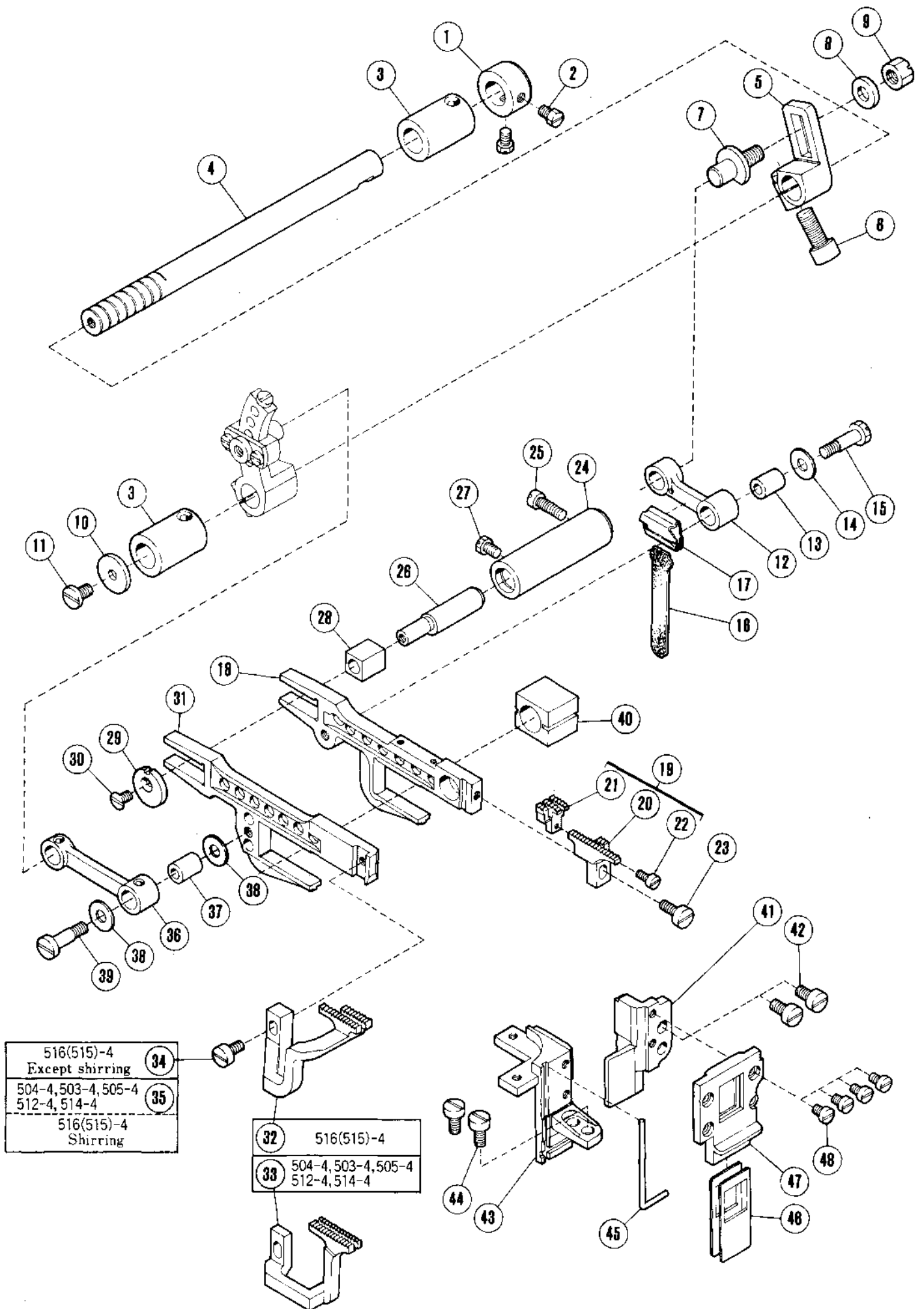

FEED MECHANISM (2)

PLEASE NOTE : 「×××××」 is one of the gauge parts.
So please refer to pages 74~132 and confirm the correct parts.

REF. NO.	PART NO.	NAME	QT.	MEMO
1	201056	COLLAR	1	
2	5084	SCREW	2	
3	209169	BUSHING	2	
4	204751	SHAFT	1	
5	208284	CRANK/MAIN FEED	1	
6	5381	SCREW	1	
7	208285	SCREW	1	
8	208286	WASHER	1	
9	5455	NUT	1	
10	204107	WASHER	1	
11	4009-1	SCREW	1	
12	204111A	LINK/MAIN FEED	1	
13	204114	BUSHING	1	
14	204115	WASHER	1	
15	5231	SCREW	1	
16	204618	OIL WICK	1	
17	204588	RETAINER	1	
18	204123A	MAIN FEED BAR	1	
19	XXXXXX	MAIN FEED DOG COMPLETE	1	
20	XXXXXX	MAIN FEED DOG	1	
21	XXXXXX	AUXILIARY FEED DOG	1	
22	2922	SCREW	1	
23	1175-2	SCREW	1	
24	204129A	BUSHING	1	
25	2133-1	SCREW	1	
26	204128A	PIN	1	
27	5084	SCREW	1	
28	205857	BLOCK/FEED BAR GUIDE	1	
29	204439A	WASHER	1	
30	5317	SCREW	1	
31	204124	DIFFERENTIAL FEED BAR	1	
32	XXXXXX	DIFFERENTIAL FEED DOG	1	
33	XXXXXX	DIFFERENTIAL FEED DOG	1	
34	1175-3	SCREW	1	
35	1189	SCREW	1	
36	204122	LINK/DIFFERENTIAL FEED	1	
37	204114	BUSHING	1	
38	204115	WASHER	2	
39	5231	SCREW	1	
40	204810	BLOCK/FEED BAR LIFT	1	
41	208108	GUIDE (RIGHT)/FEED BAR	1	
42	5205	SCREW	2	
43	208952	GUIDE (LEFT)/FEED BAR	1	
44	5205	SCREW	2	
45	208168	GASKET	1	
46	208109	OIL SHIELD/FEED BAR GUIDE	2	
47	208625	INSERT PLATE	1	
48	5346	SCREW	4	

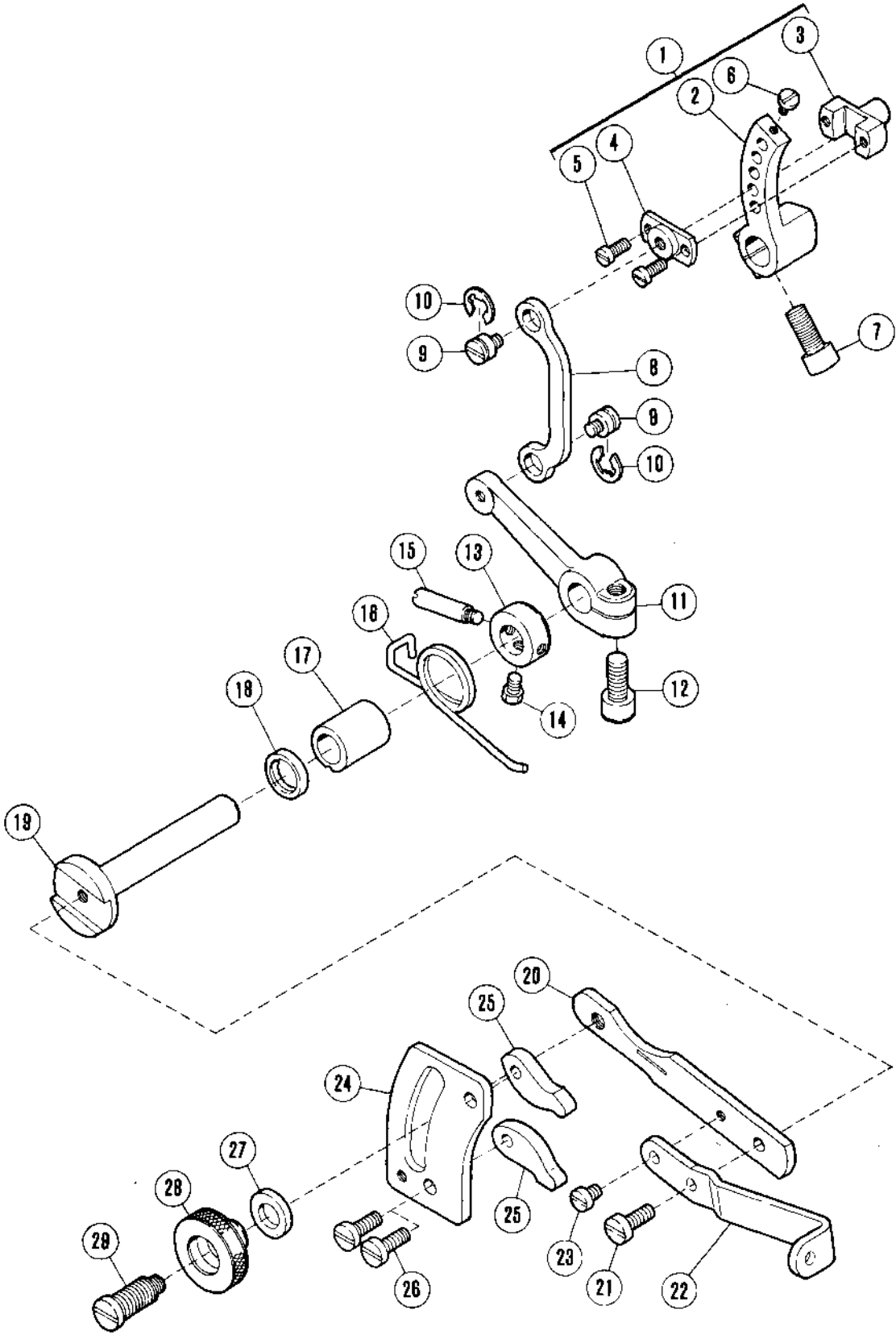

FEED MECHANISM (3)

REF. NO.	PART NO.	NAME	QT.	MEMO
1	208273	REGULATOR COMPLETE/DIFF. FEED	1	
2	208274	CRANK	1	
3	208275	BLOCK	1	
4	208276	COVER	1	
5	5029	SCREW	2	
6	5141	SCREW	1	
7	5381	SCREW	1	
8	204140A	LINK/DIFF. FEED REGULATING	1	
9	5316	SCREW	2	
10	202522	RING	2	
11	204139A	LEVER/DIFF. FEED REGULATING	1	
12	5381	SCREW	1	
13	204754A	COLLAR	1	
14	5084	SCREW	1	
15	204757	PIN	1	
16	204756	SPRING	1	
17	210164	BUSHING	1	
18	204052A	OIL SEAL	1	
19	204752	SHAFT	1	
20	204755	LEVER/DIFF. FEED REGULATING	1	
21	5118	SCREW	1	
22	204883	LEVER	1	
23	1216	SCREW	1	
24	204142B	REGULATING PLATE	1	
25	204143A	STOPPER	2	
26	5118	SCREW	2	
27	202868	WASHER	1	
28	204870	THUMB NUT	1	
29	5321A	SCREW	1	

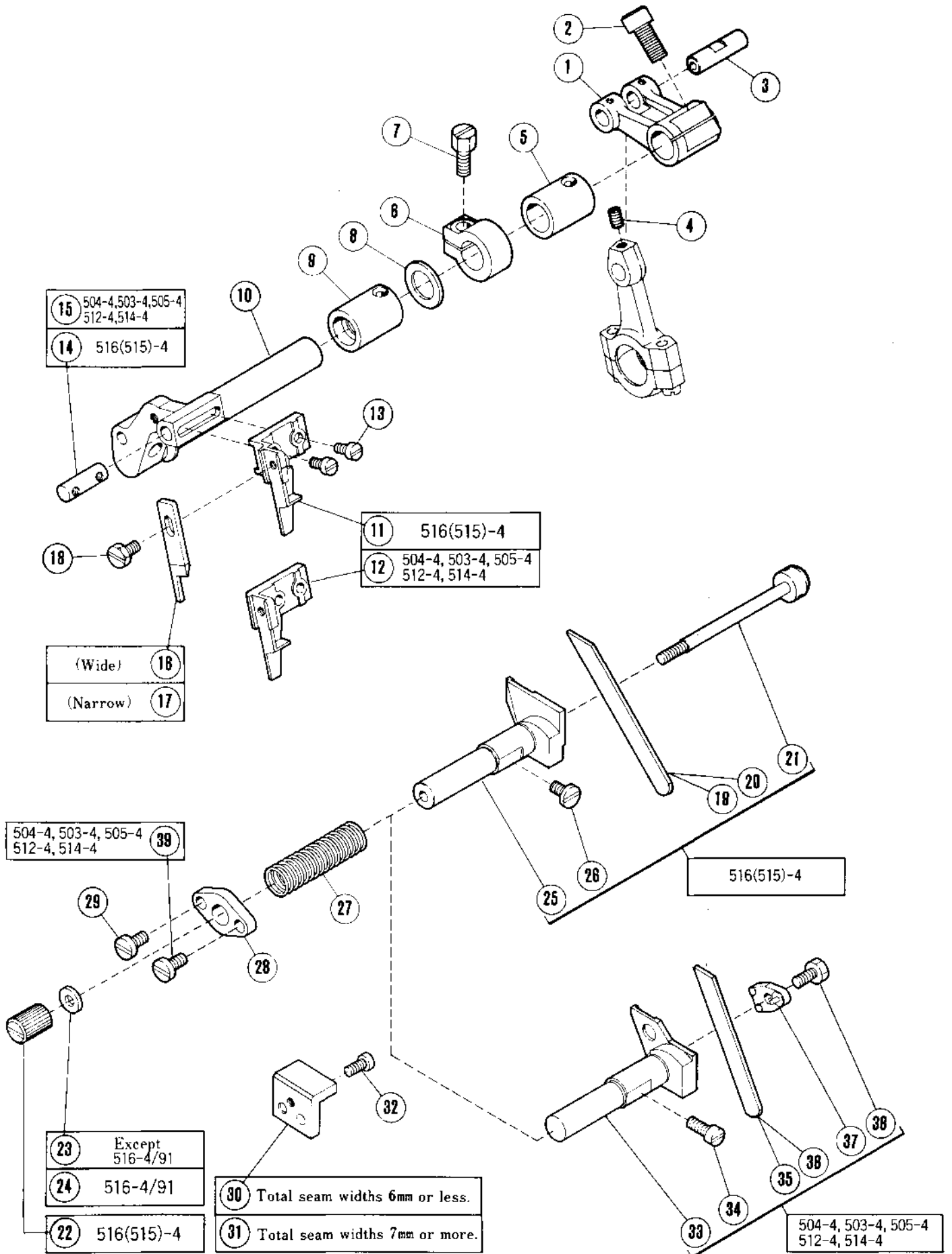

KNIFE DRIVE MECHANISM

REF. NO.	PART NO.	NAME	QT.	MEMO
1	204147	CRANK/UPPER KNIFE	1	
2	5381	SCREW	1	
3	204146	PIN	1	
4	1458	SCREW	1	
5	210067	BUSHING	1	
6	206181B	COLLAR	1	
7	5001	SCREW	1	
8	208235	WASHER	1	
9	204149	BUSHING	1	
10	208693	UPPER KNIFE LEVER	1	
11	208402	UPPER KNIFE CLAMP	1	
12	204638	UPPER KNIFE CLAMP	1	
13	1175-2	SCREW	2	
14	204154	PIN	1	
15	204796	PIN	1	
16	201121A	UPPER KNIFE	1	
17	202527A	UPPER KNIFE (NARROW)	1	
18	5088	SCREW	1	
19	204161	LOWER KNIFE	1	
20	204351	LOWER KNIFE	1	
21	204162	CLAMP STUD/LOWER KNIFE	1	
22	5260	NUT	1	
23	200098	WASHER	1	
24	209173	WASHER	1	
25	208404	LOWER KNIFE HOLDER	1	
26	4009-1	SCREW	1	
27	204158	SPRING	1	
28	204159	STOPPER	1	
29	5117	SCREW	1	
30	204160A	GUIDE/LOWER BAR	1	
31	208096	GUIDE/LOWER KNIFE HOLDER	1	
32	1175-2	SCREW	1	
33	208851	LOWER KNIFE HOLDER	1	
34	5002	SCREW	1	
35	202295	LOWER KNIFE/THICK	1	
36	201127	LOWER KNIFE/THIN	1	
37	210184	CLAMP/LOWER KNIFE	1	
38	2193	SCREW	1	
39	5117	SCREW	1	

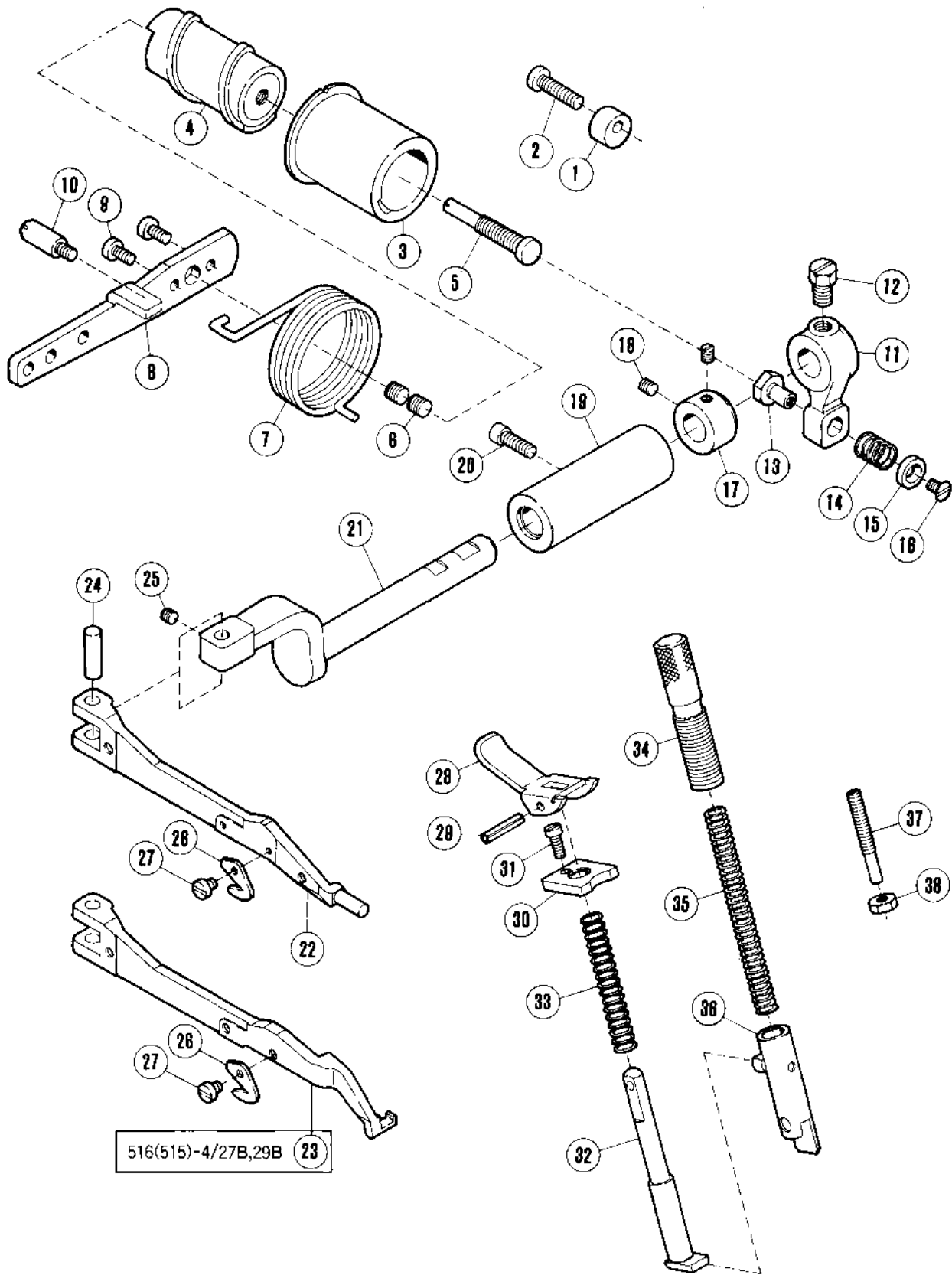

PRESSER FOOT MECHANISM (1)

REF. NO.	PART NO.	NAME	QT.	MEMO
1	202683	STOPPER	1	
2	5118	SCREW	1	
3	204930	BUSHING	1	
4	204929	FOOT LIFT CAM	1	
5	208316	SCREW	1	
6	2913-2	SCREW	2	
7	204178	SPRING	1	
8	204177B	LEVER/FOOT LIFT	1	
9	1202	SCREW	2	
10	5232	SCREW	1	
11	208313	LEVER/INTERMEDIATE	1	
12	2022-4	SCREW	1	
13	208314	PIN	1	
14	208315	SPRING	1	
15	202757A	WASHER	1	
16	5317	SCREW	1	
17	201056	COLLAR	1	
18	1457	SCREW	2	
19	208535	BUSHING	1	
20	2133-1	SCREW	1	
21	208534	SHAFT/FOOT LIFT	1	
22	208526	PRESSER ARM	1	
23	209337	PRESSER ARM	1	
24	208549	PIN	1	
25	1457-1	SCREW	1	
26	202451	CHAIN CUTTER	1	
27	2921	SCREW	1	
28	208598	LEVER/HAND LIFT	1	
29	202647A	PIN	1	
30	208599	BUSHING	1	
31	5029	SCREW	1	
32	202645	PLUNGER	1	
33	201395	SPRING	1	
34	208774	THUMB SCREW	1	
35	208773	SPRING	1	
36	208537	PRESSER BAR COMPLETE	1	
37	5271	SCREW	1	
38	3044	NUT	1	

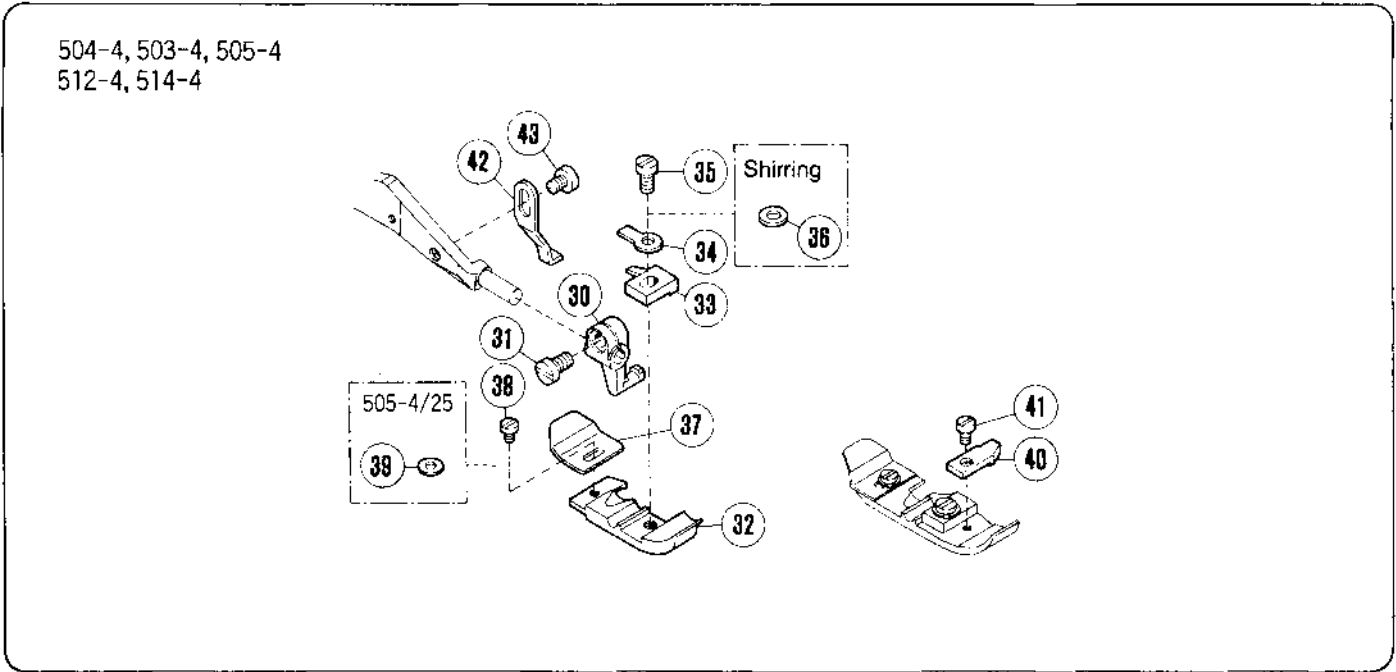
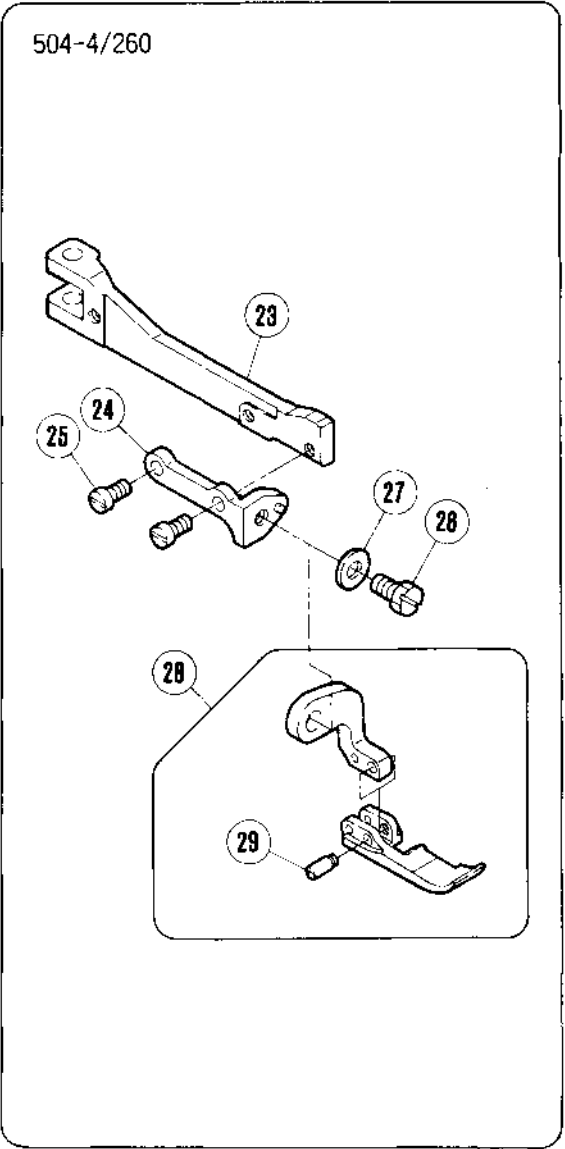
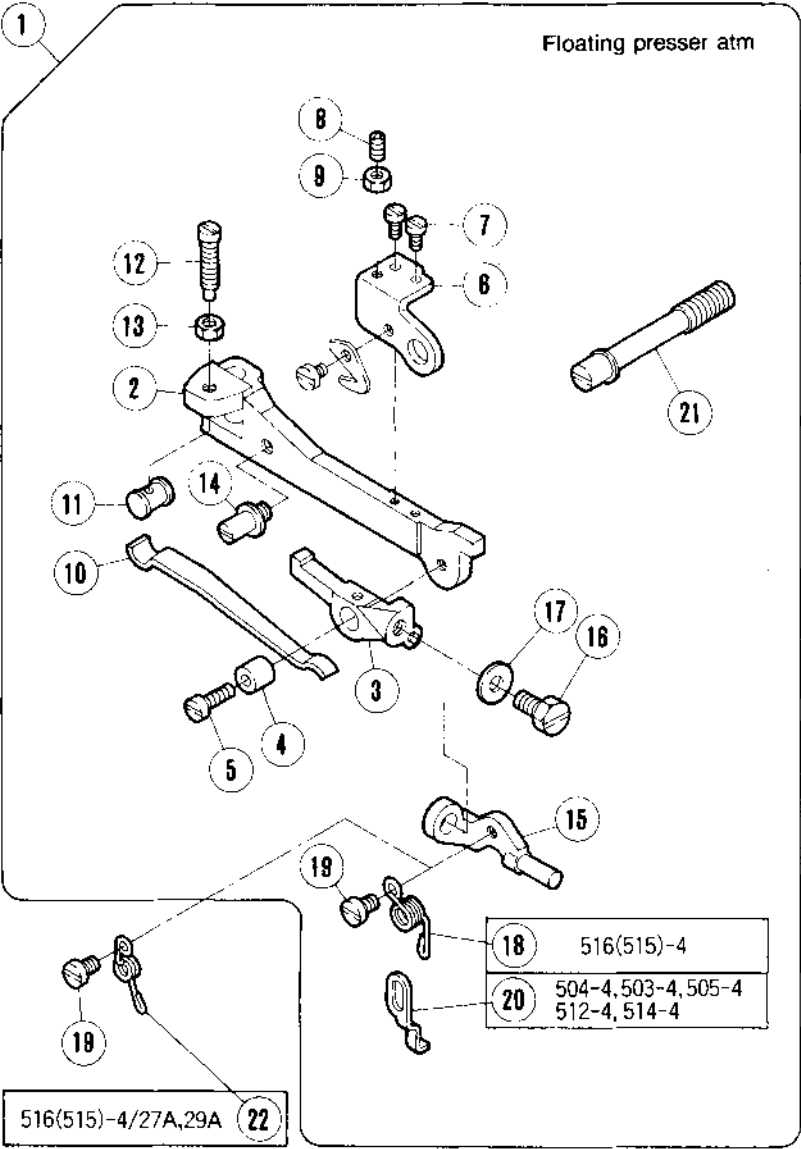

PRESSER FOOT MECHANISM (2)

PLEASE NOTE : 「×××××」 is one of the gauge parts.
So please refer to pages 74~132 and confirm the correct parts.

REF. NO.	PART NO.	NAME	QT.	MEMO
1	209307	PRESSER ARM COMPLETE	1	
2	209308	PRESSER ARM	1	
3	209309	LEVER	1	
4	211511	BUSHING	1	
5	5003	SCREW	1	
6	209311	LEVER HOLDER	1	
7	2922	SCREW	2	
8	5427	SCREW	1	
9	5409	NUT	1	
10	211514	FLAT SPRING	1	
11	209312	SPRING GUIDE	1	
12	5538	SCREW	1	
13	3091	NUT	1	
14	209313	SCREW	1	
15	211516	BRACKET	1	
16	2193	SCREW	1	
17	201185	WASHER	1	
18	211517	SPRING	1	
19	2921	SCREW	1	
20	209314	STOPPER/PRESSER FOOT	1	
21	5552	SCREW	1	
22	211944	SPRING	1	
23	209232	PRESSER ARM	1	
24	209230	BRACKET	1	
25	1196	SCREW	2	
26	2193	SCREW	1	
27	201185	WASHER	1	
28	209226	PRESSER FOOT COMPLETE	1	
29	209229-B	SCREW	1	
30	208525-B	BRACKET/PRESSER FOOT	1	
31	5328	SCREW	1	
32	XXXXXX	PRESSER FOOT	1	
33	XXXXXX	PRESSER FOOT FINGER	1	
34	201156	SET PLATE/PRESSER FOOT	1	
35	5089	SCREW	1	
36	202588	WASHER	1	
37	XXXXXX	PRESSER FOOT UNCURLER	1	
38	5030	SCREW	1	
39	210585	WASHER	1	
40	XXXXXX	FABRIC GUARD	1	
41	1231	SCREW	1	
42	208547	REGULATOR	1	
43	2921	SCREW	1	

516(515)-4

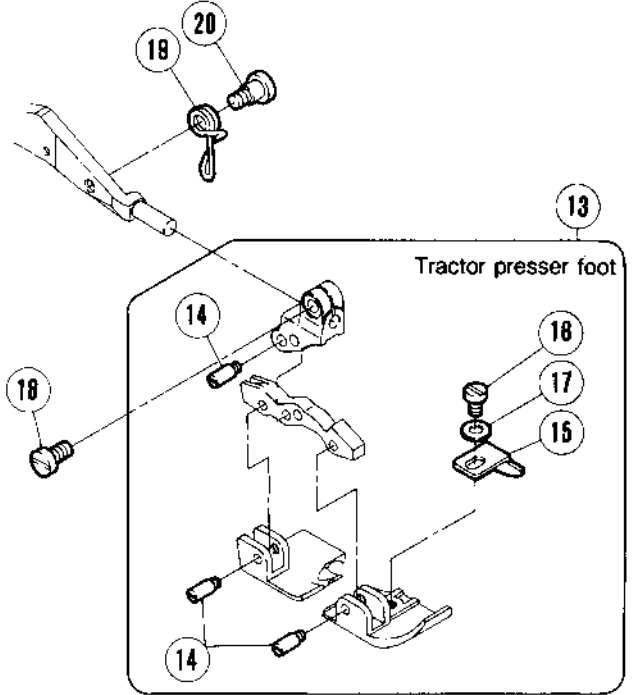
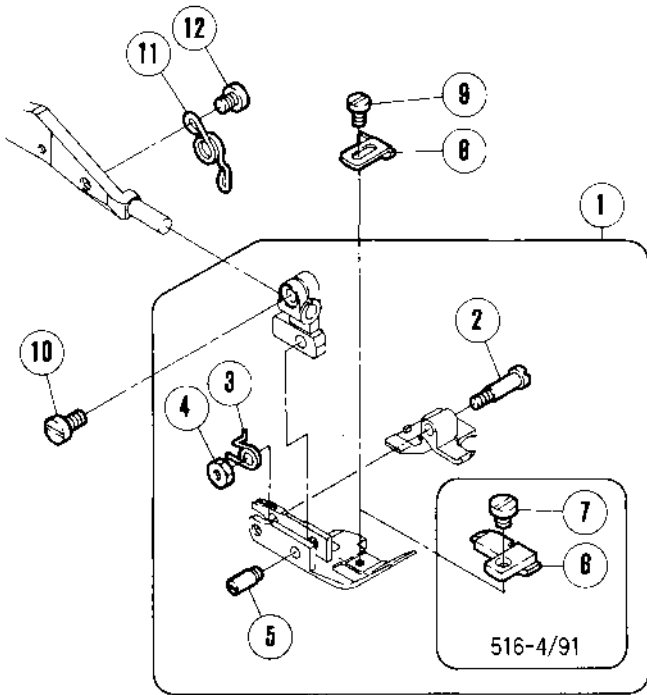

516(515)-4/27A,29A

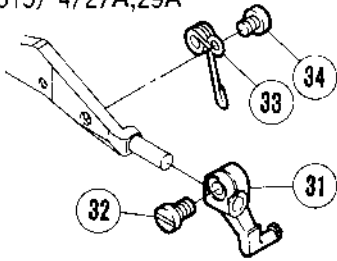

516(515)-4/27B,29B

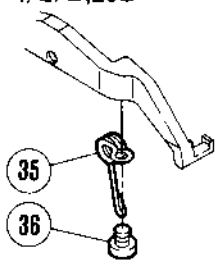

21

Small foot
(Good for cornering)

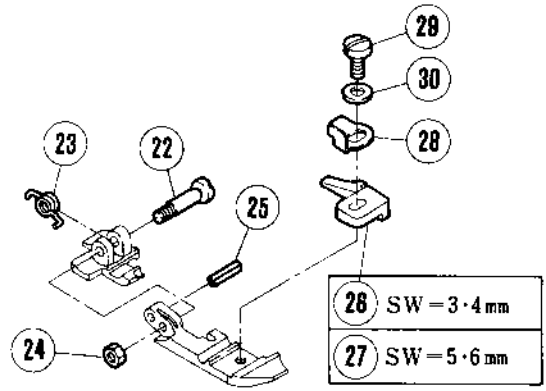

PRESSER FOOT MECHANISM (3)

PLEASE NOTE : 「XXXXXX」 is one of the gauge parts.
So please refer to pages 74~132 and confirm the correct parts.

REF. NO.	PART NO.	NAME	QT.	MEMO
1	XXXXXX	PRESSER FOOT COMPLETE	1	
2	208528-B	SCREW	1	
3	208913	SPRING	1	
4	5409	NUT	1	
5	208958-B	SCREW	1	
6	208891	PRESSER FOOT FINGER	1	
7	2921	SCREW	1	
8	XXXXXX	FABRIC GUARD	1	
9	5030	SCREW	1	
10	5328	SCREW	1	
11	208529	SPRING	1	
12	2921	SCREW	1	
13	XXXXXX	PRESSER FOOT COMPLETE	1	
14	208958-B	SCREW	3	
15	204683	FABRIC GUARD	1	
16	5157	SCREW	1	
17	202875	WASHER	1	
18	5328	SCREW	1	
19	208978	SPRING	1	
20	5291	SCREW	1	
21	XXXXXX	PRESSER FOOT COMPLETE	1	
22	211919	PIN	1	
23	211918	SPRING	1	
24	3150	NUT	1	
25	211920	PIN	1	
26	211915	PRESSER FOOT FINGER	1	
27	211916	PRESSER FOOT FINGER	1	
28	211917	BRACKET	1	
29	5089	SCREW	1	
30	300248	WASHER	1	
31	211905	BRACKET/PRESSER FOOT	1	
32	5328	SCREW	1	
33	209338	SPRING	1	
34	2921	SCREW	1	
35	211904	SPRING	1	
36	2921	SCREW	1	

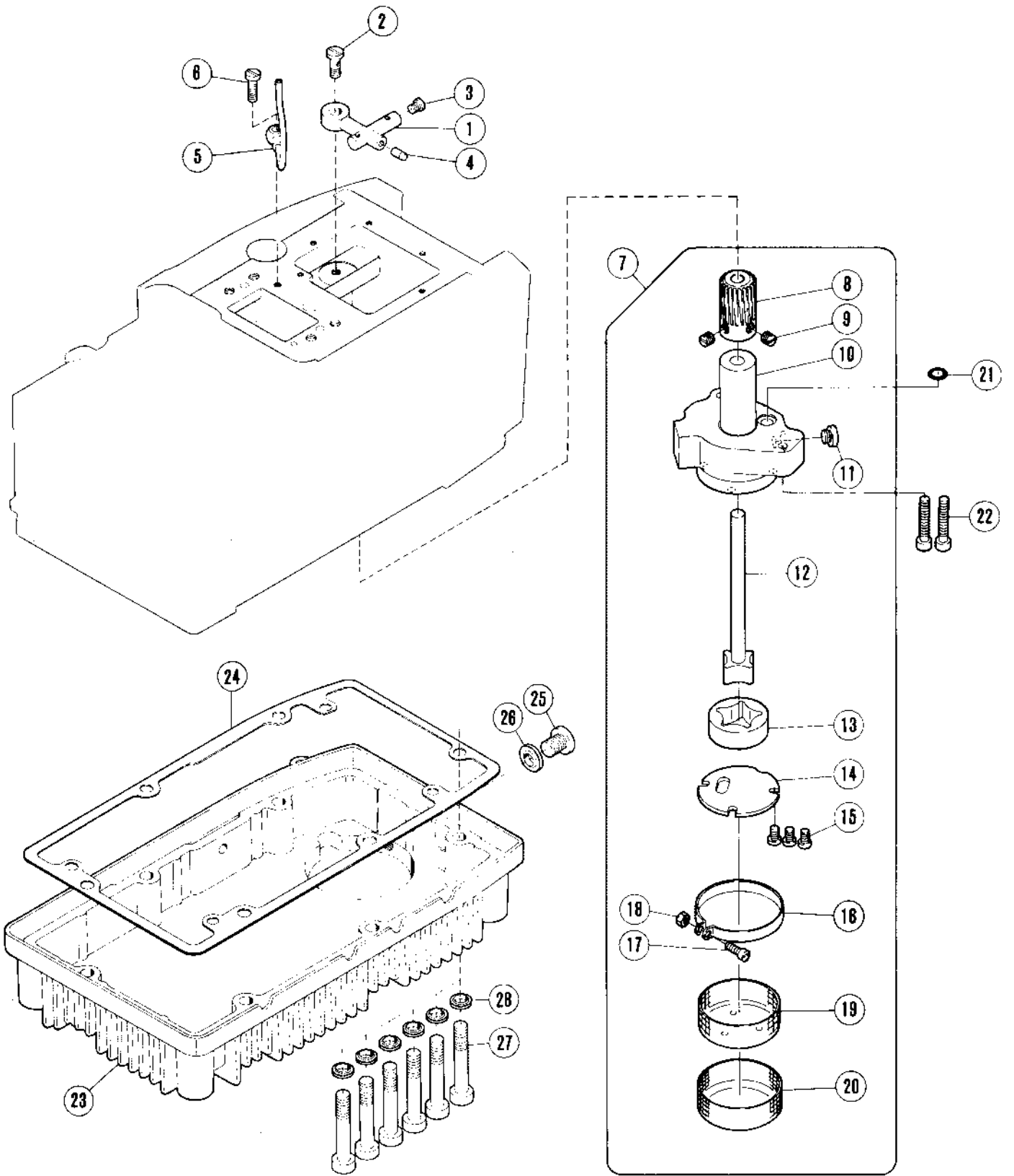

LUBRICATION MECHANISM

REF. NO.	PART NO.	NAME	QT.	MEMO
1	204193	OIL DISTRIBUTOR	1	
2	200152	JOINT SCREW	1	
3	201323	SCREW	1	
4	202903	PLUG	1	
5	204194	PIPE COMPLETE	1	
6	201758	JOINT SCREW	1	
7	204593	TROCHOID PUMP ASSEMBLY	1	
8	204187	WORM WHEEL	1	
9	5060	SCREW	2	
10	209407	TROCHOID PUMP	1	
11	5145	SCREW	1	
12	212978-91	ROTOR (INSIDE) SHAFT	1	
13	212981	ROTOR (OUTSIDE)	1	
14	212982A	PLATE	1	
15	5328	SCREW	3	
16	209410	CLAMP	1	
17	1170-1	SCREW	1	
18	3091	NUT	1	
19	209408	FILTER (INSIDE)	1	
20	209409	FILTER (OUTSIDE)	1	
21	204185	O RING	1	
22	5094	SCREW	2	
23	208260	OIL RESERVOIR	1	
24	208318	GASKET	1	
25	5138B	SCREW	1	
26	202287A	WASHER	1	
27	5150B	BOLT	6	
28	204806	WASHER	6	

OPTION

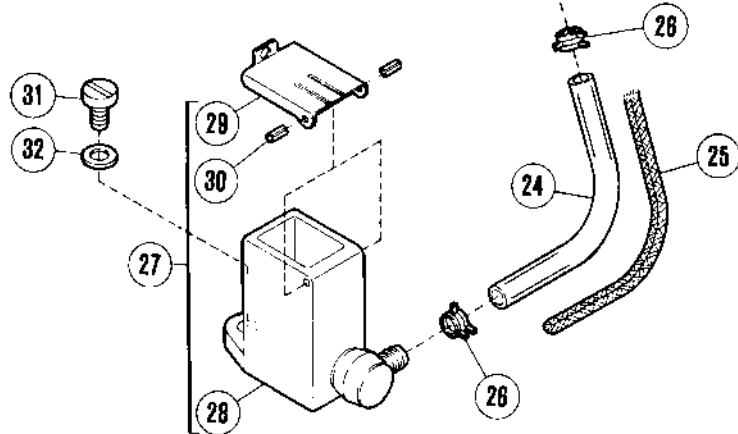
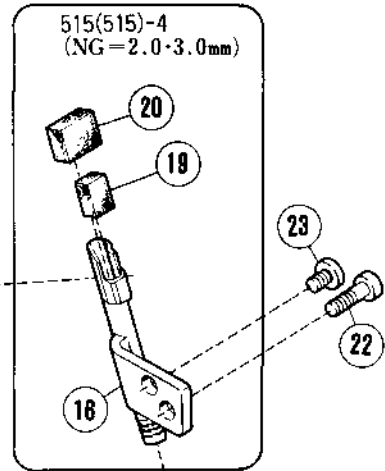
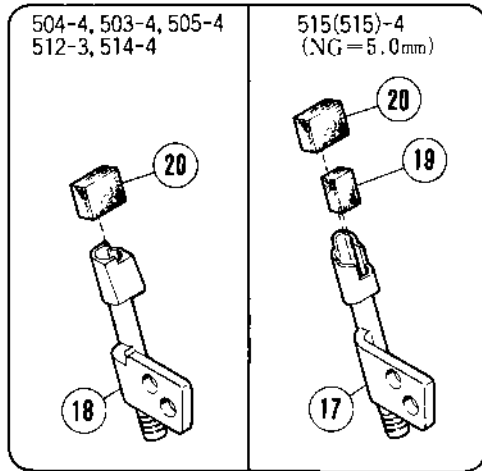
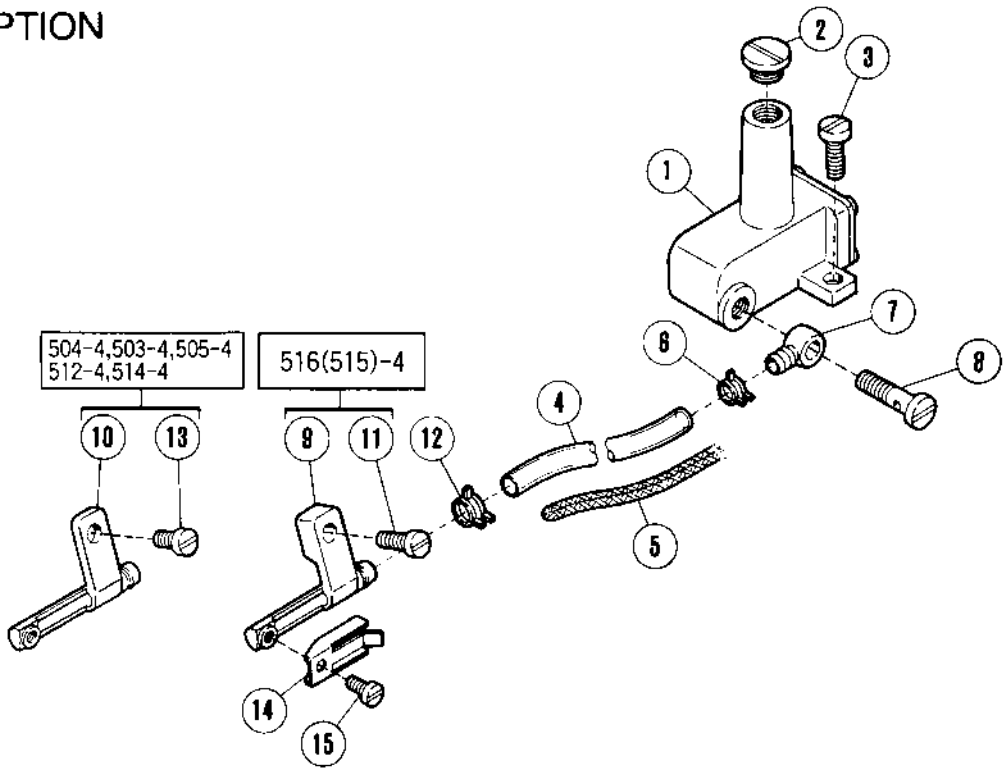

H. R. DEVICE (OPTION)

REF. NO.	PART NO.	NAME	QT.	MENO
1	208308	SILICONE OIL RESERVOIR (UPPER)	1	
2	5242	SCREW	1	
3	5118	SCREW	1	
4	204921	TUBE	1	
5	202176	OIL WICK	1	
6	200155	TUBE CLAMP	1	
7	200136	JOINT	1	
8	200152	JOINT SCREW	1	
9	208486	THREAD LUBRICATOR	1	
10	208446	THREAD LUBRICATOR	1	
11	5345	SCREW	1	
12	202199	CLAMP	1	
13	4009-1	SCREW	1	
14	208487	PLATE	1	
15	5012	SCREW	1	
16	204259	TUBE	1	
17	204435	TUBE	1	
18	204651	TUBE	1	
19	240178	OIL FELT	1	
20	204466	OIL WICK	1	
21	210766	PIN	1	
22	5010	SCREW	1	
23	1206	SCREW	1	
24	204921	TUBE	1	
25	202176	OIL WICK	1	
26	200155	TUBE CLAMP	2	
27	209411-91	SILICONE OIL RESERVOIR (LOWER)	1	
28	209412-91	SILICONE OIL RESERVOIR (LOWER)	1	
29	204862	CAP COVER	1	
30	206781	PIN	2	
31	5345	SCREW	1	
32	201185	WASHER	1	

504-4/21P1,P2
 514-4/62P1,P2
 516-4/38P1,P2

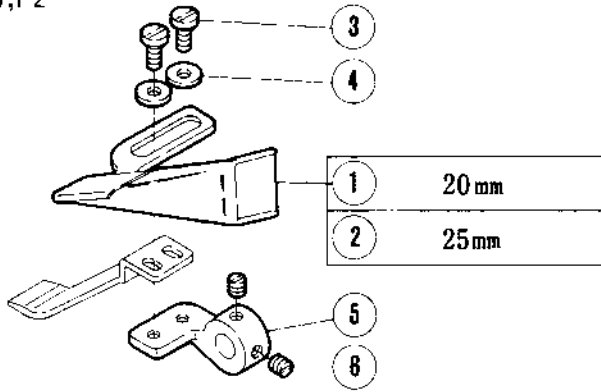

18 504-4/21P2
 514-4/62P2
 516-4/38P2

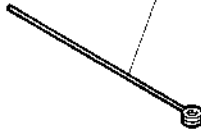

- ① • 504-4/21P2, 514-4/62P2
 • 516-4/38P2 (Option)
- ② • 516-4/38P2
 • 504-4/21P2, 514-4/62P2 (Option)

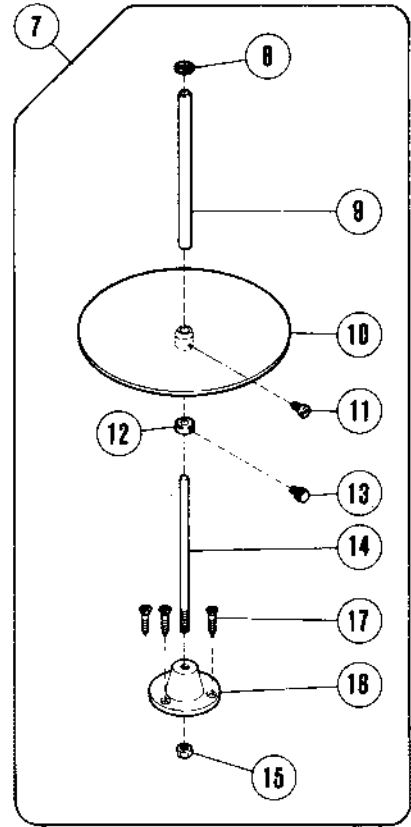

504-4/21P1, 504-4/21P2
 514-4/62P1, 514-4/62P2

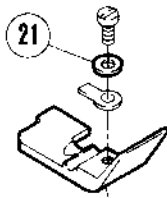

18 CD=2.0mm
 20 CD=3.0mm
 CD=Cord Diameter

516(515)-4/38P1, 516(515)-4/38P2

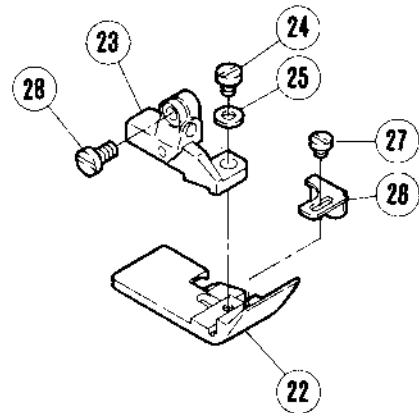

ATTACHMENT FOR PIPING (1)

REF. NO.	PART NO.	NAME	QT.	MEMO
1	211885	BINDER (20)	1	
2	211886	BINDER (25)	1	
3	1202	SCREW	1	
4	167066	WASHER	1	
5	210962	BRACKET/BINDER	1	
6	5210	SCREW	2	
7	403	TAPE DISC ASSEMBLY	1	
8	406	FELT	1	
9	405	FIXING ROD	1	
10	404	TAPE DISC	1	
11	4012	SCREW	1	
12	407	COLLAR	1	
13	408	ADJUSTING SCREW	1	
14	409	SHAFT	1	
15	4818	NUT	1	
16	410	BRACKET	1	
17	4908	SCREW	3	
18	413	TAPE INSERTING TOOL	1	
19	208782	PIPING FOOT	1	
20	208783	PIPING FOOT	1	
21	202588	WASHER	1	
22	204502A	PIPING FOOT	1	
23	208554	BRACKET COMPLETE	1	
24	2921	SCREW	1	
25	202875	WASHER	1	
26	204460	FABRIC GUARD	1	
27	5077	SCREW	1	
28	5328	SCREW	1	

514-4/64P1, 514-4/64P2
 504-4/47P1, 504-4/47P2

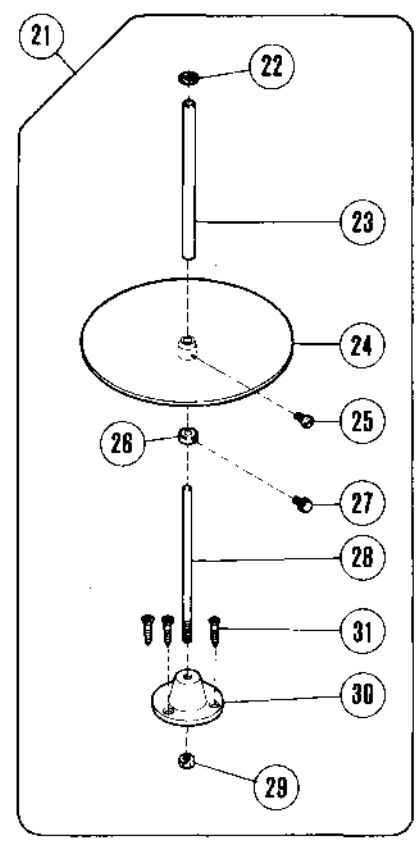
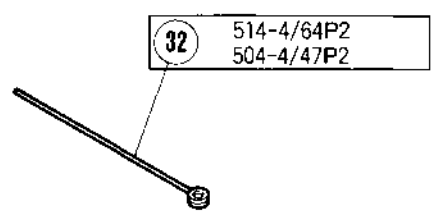
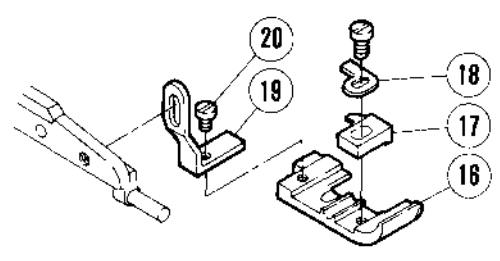
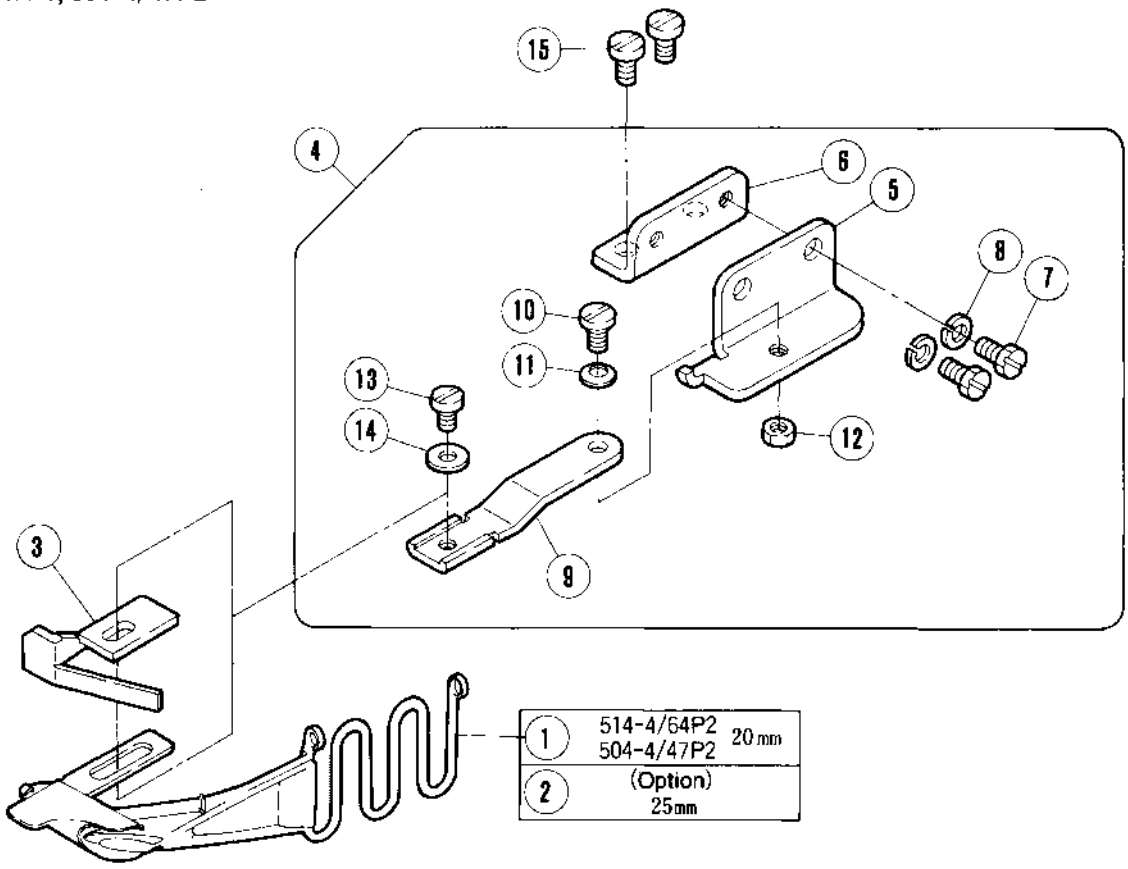

ATTACHMENT FOR PIPING (2)

PLEASE NOTE: 「×××××」 is one of the gauge parts.
So please refer to pages 74~132 and
confirm the correct parts.

REF. NO.	PART NO.	NAME	QT.	MEMO
1	211880	BINDER (20)	1	
2	211946	BINDER (25)	1	
3	211879	EDGE GUIDE	1	
4	209335	GUIDE SET	1	
5	204452	BRACKET/EDGE GUIDE	1	
6	204451	BRACKET	1	
7	2193	SCREW	2	
8	202286	SPRING WASHER	2	
9	209324	HINGE	1	
10	5184	SCREW	1	
11	201191	SPRING	1	
12	3044	NUT	1	
13	1202	SCREW	1	
14	167066	WASHER	1	
15	5117	SCREW	2	
16	211873-TA	PRESSER FOOT	1	
17	XXXXXX	PRESSER FOOT FINGER	1	
18	211876	SET PLATE/PRESSER FOOT	1	
19	211877	STOPPER/PRESSER FOOT	1	
20	1333	SCREW	1	
21	403	TAPE DISC ASSEMBLY	1	
22	406	FELT	1	
23	405	FIXING ROD	1	
24	404	TAPE DISC	1	
25	4012	SCREW	1	
26	407	COLLAR	1	
27	408	ADJUSTING SCREW	1	
28	409	SHAFT	1	
29	4818	NUT	1	
30	410	BRACKET	1	
31	4908	SCREW	3	
32	413	TAPE INSERTING TOOL	1	

504-4/350P1, 504-4/350P2
 514-4/351P1, 514-4/351P2

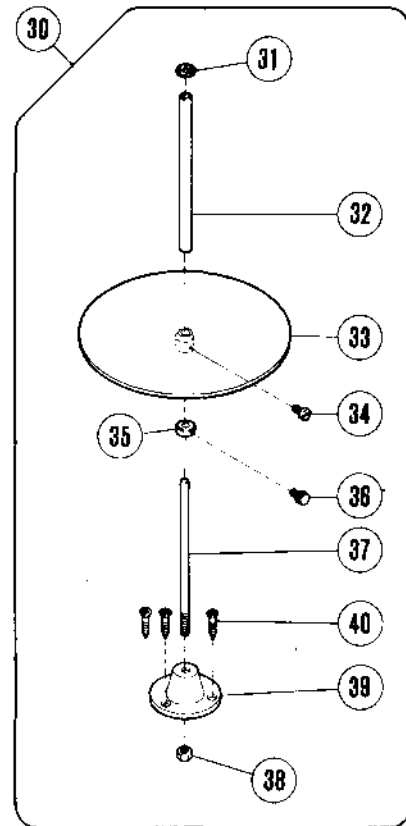
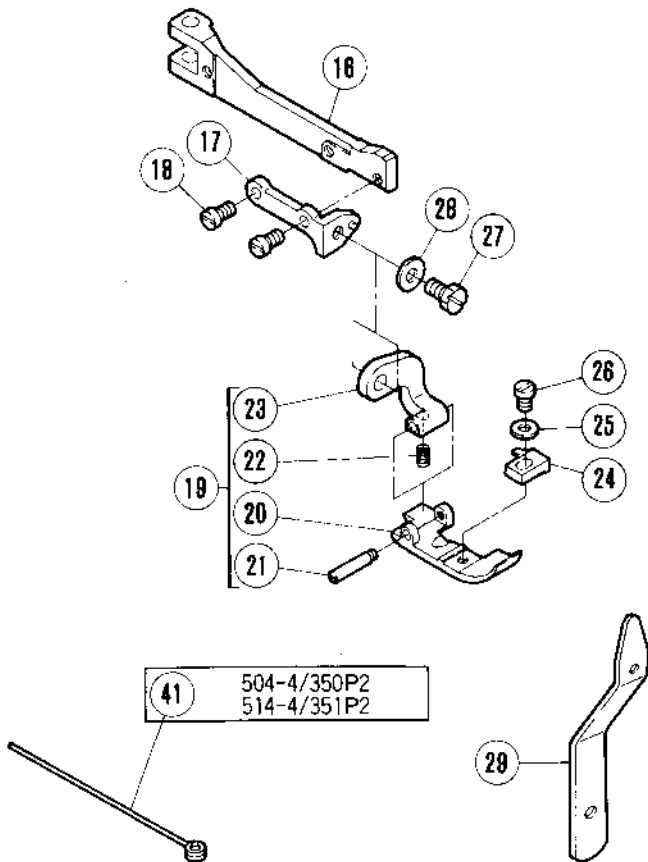
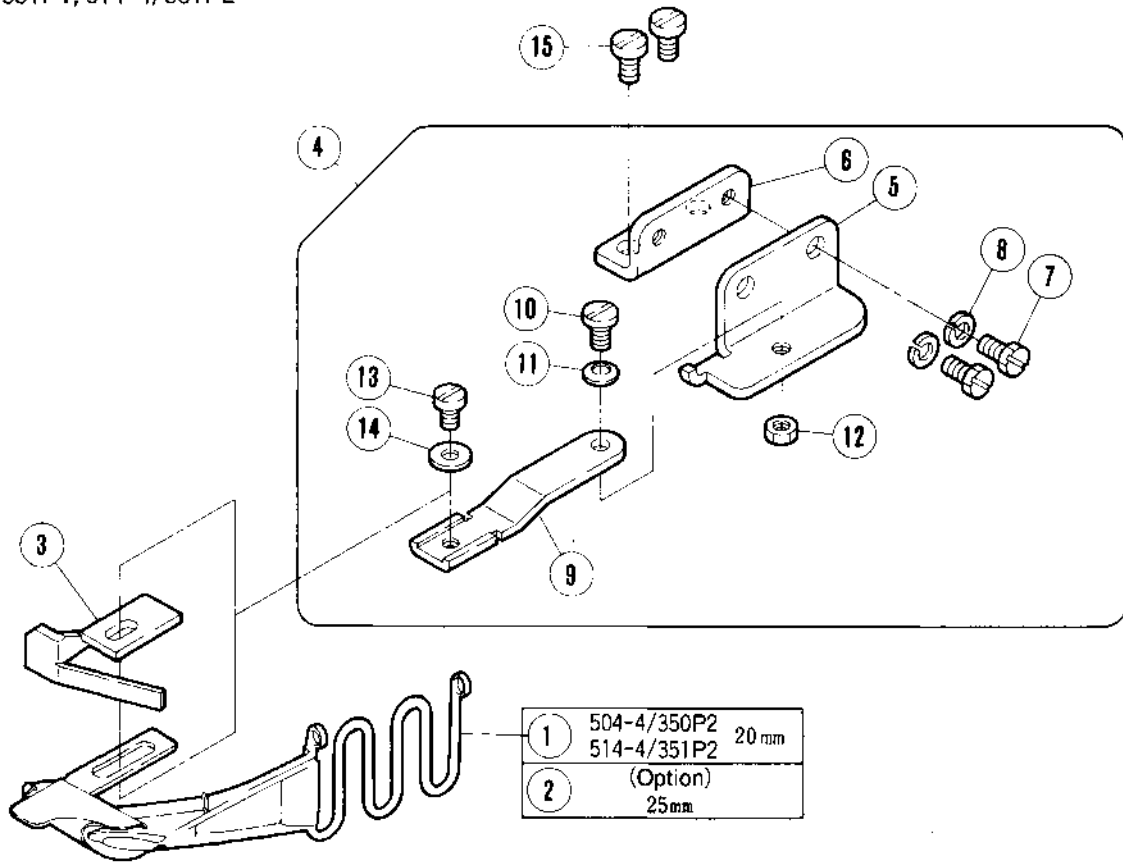

ATTACHMENT FOR PIPING (3)

PLEASE NOTE:「×××××」 is one of the gauge parts.
So please refer to pages 74~132 and
confirm the correct parts.

REF. NO.	PART NO.	NAME	QT.	MEMO
1	211880	BINDER (20)	1	
2	211946	BINDER (25)	1	
3	211879	EDGE GUIDE	1	
4	209335	GUIDE SET	1	
5	204452	BRACKET/EDGE GUIDE	1	
6	204451	BRACKET	1	
7	2193	SCREW	2	
8	202286	SPRING WASHER	2	
9	209324	HINGE	1	
10	5184	SCREW	1	
11	201191	SPRING	1	
12	3044	NUT	1	
13	1202	SCREW	1	
14	167066	WASHER	1	
15	5117	SCREW	2	
16	209232	PRESSER ARM	1	
17	209230	BRACKET	1	
18	1196	SCREW	2	
19	209333-TA	PRESSER FOOT COMPLETE	1	
20	211895-TA	PRESSER FOOT BODY	1	
21	211897-B	PIN	1	
22	211902	SPRING	1	
23	209334	HINGE	1	
24	XXXXXX	PRESSER FOOT FINGER	1	
25	202588	WASHER	1	
26	5089	SCREW	1	
27	2193	SCREW	1	
28	201185	WASHER	1	
29	211949	CORD GUIDE PLATE	1	
30	403	TAPE DISC ASSEMBLY	1	
31	406	FELT	1	
32	405	FIXING ROD	1	
33	404	TAPE DISC	1	
34	4012	SCREW	1	
35	407	COLLAR	1	
36	408	ADJUSTING SCREW	1	
37	409	SHAFT	1	
38	4818	NUT	1	
39	410	BRACKET	1	
40	4908	SCREW	3	
41	413	TAPE INSERTING TOOL	1	

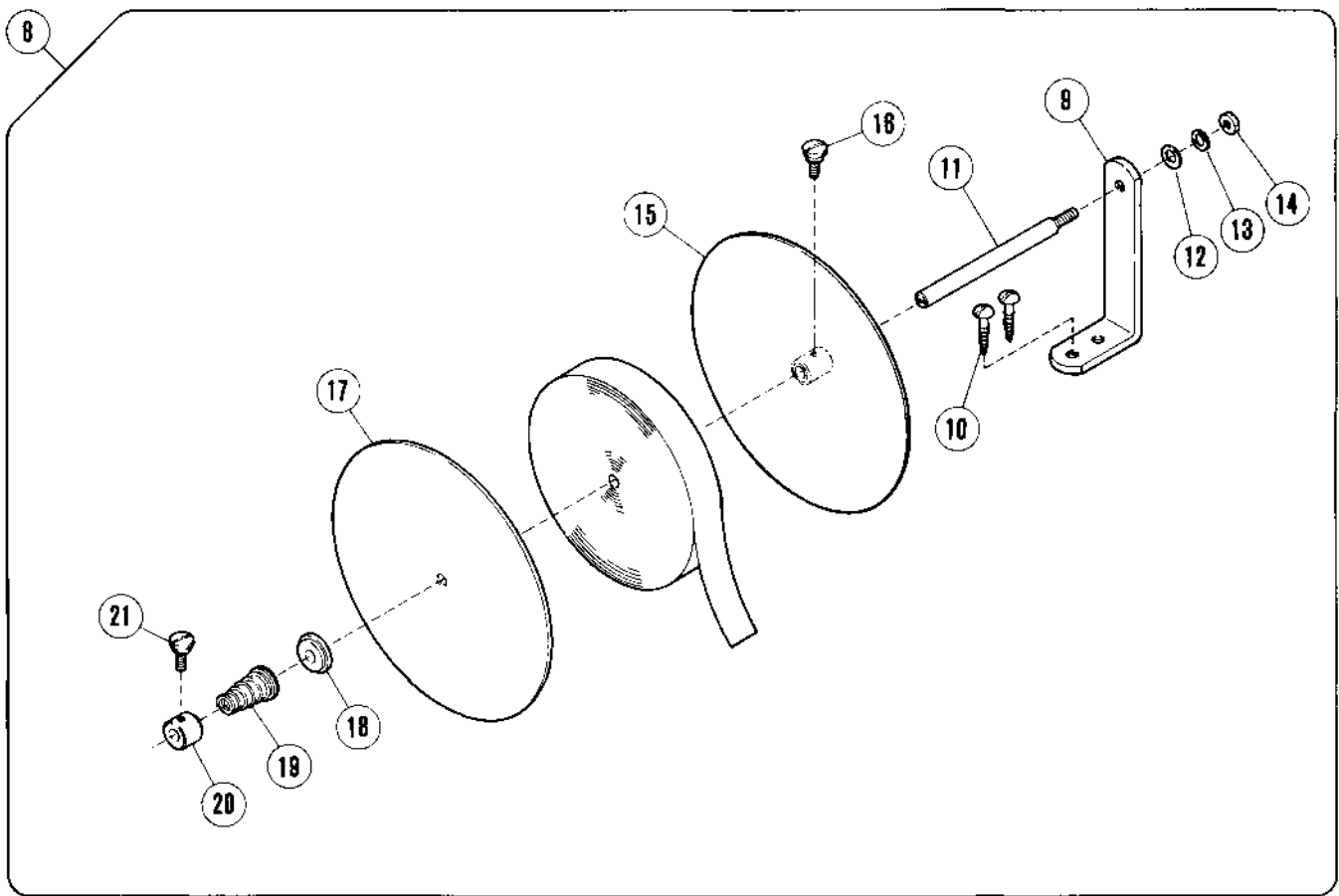
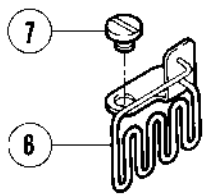
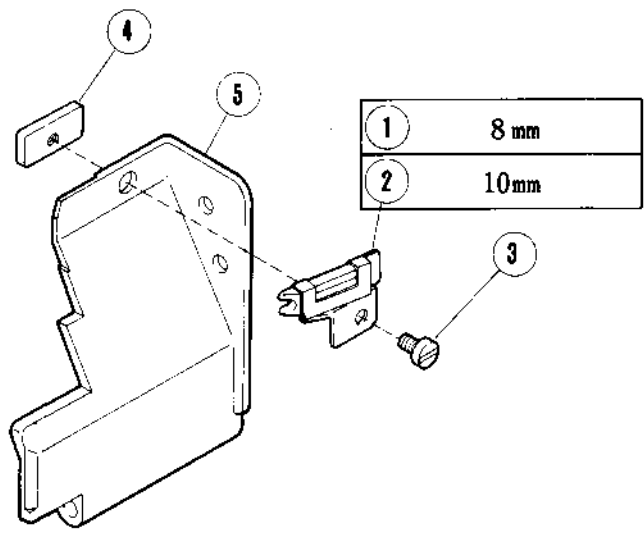

ATTACHMENT FOR TAPE

REF. NO.	PART NO.	NAME	QT.	MEMO
1	208994	BINDER (8)	1	
2	209200	BINDER (10)	1	
3	1216	SCREW	1	
4	208997	BINDER GUIDE	1	
5	209000	FRONT COVER (LEFT)	1	
6	209206	TAPE GUIDE	1	
7	2905	SCREW	1	
8	337	TAPE DISC ASSEMBLY	1	
9	344	BRACKET	1	
10	4911	SCREW	2	
11	341	ROD	1	
12	189	WASHER	1	
13	303067	SPRING WASHER	1	
14	4805	NUT	1	
15	338	TAPE DISC	1	
16	339	SCREW	1	
17	340	TAPE DISC COVER	1	
18	467	SPRING SEAT	1	
19	343	SPRING	1	
20	468	COLLAR	1	
21	339	SCREW	1	

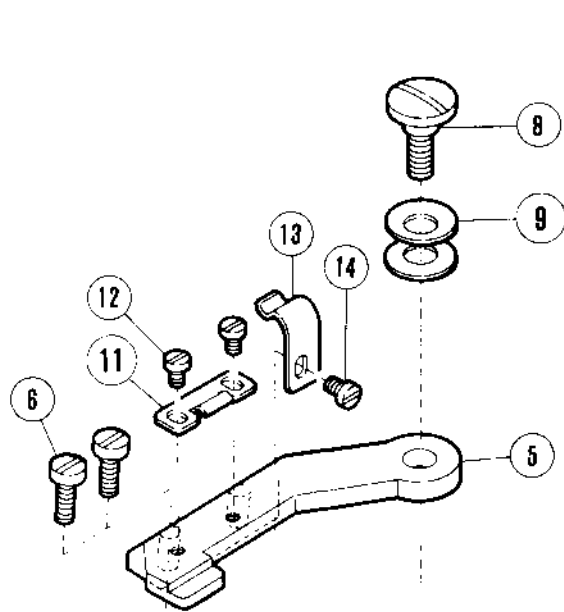
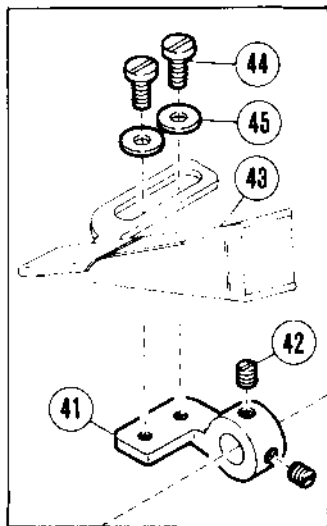
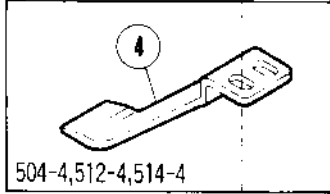
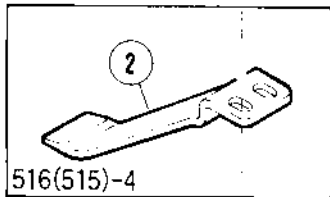
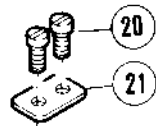

1
516(515)-4
2 • 5 ~ 40

3
504-4, 512-4
514-4
4 ~ 40

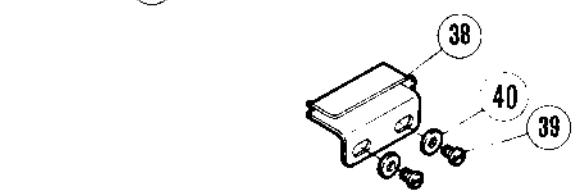
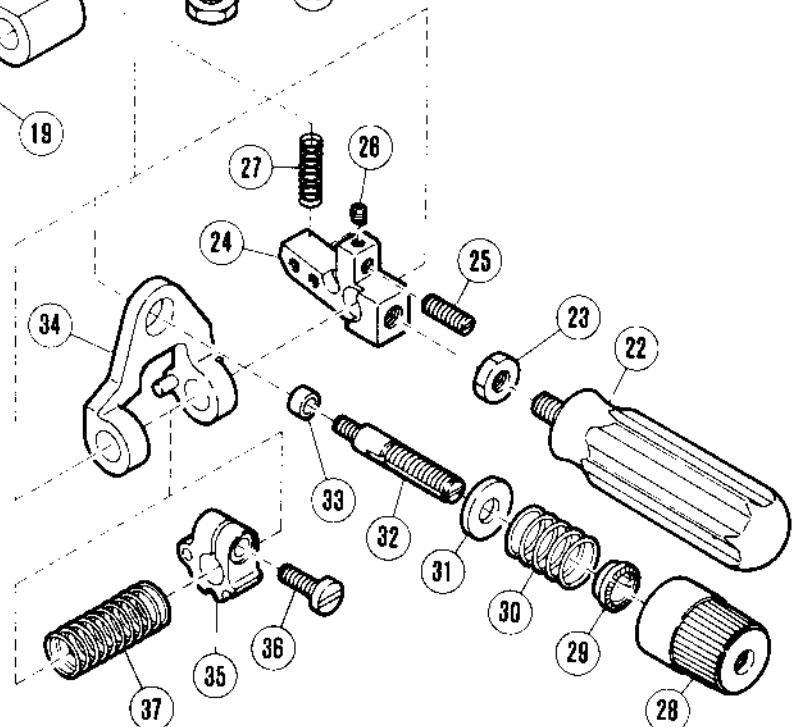
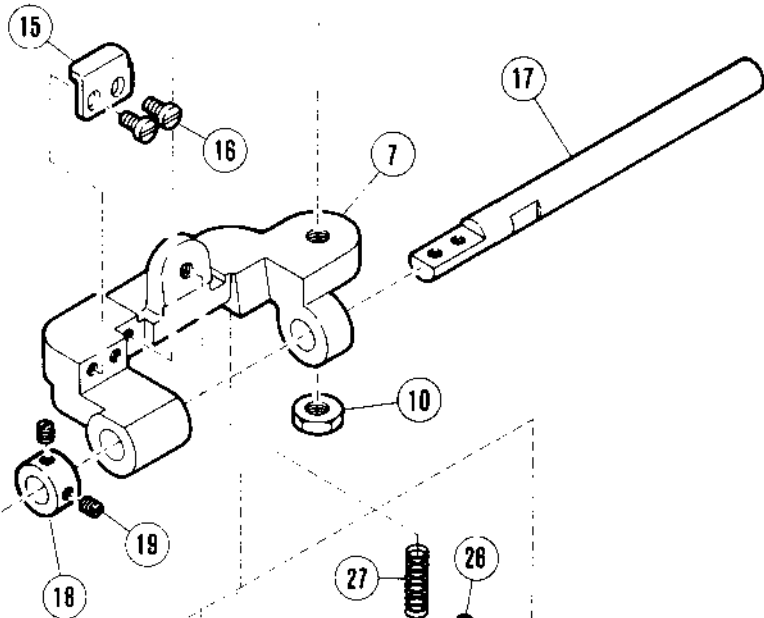

ATTACHMENT FOR SHIRRING

REF. NO.	PART NO.	NAME	QT.	MEMO
1	208658	SHIRRING ATTACHMENT COMPLETE	1	
2	210953	BLADE	1	
3	208659	SHIRRING ATTACHMENT COMPLETE	1	
4	210954	BLADE	1	
5	208660	BRACKET	1	
6	5152	SCREW	1	
7	210936	BRACKET	1	
8	5513	SCREW	1	
9	204888	SPRING	1	
10	5104	NUT	1	
11	210947	FLAT SPRING	1	
12	1206	SCREW	2	
13	210946	FLAT SPRING	1	
14	1206	SCREW	1	
15	210945	STOPPER	1	
16	5328	SCREW	1	
17	210937	SHAFT	1	
18	206225	COLLAR	1	
19	1457-1	SCREW	2	
20	5029	SCREW	2	
21	210955	WASHER	1	
22	210948	LEVER	1	
23	5104	NUT	1	
24	211614	BRACKET	1	
25	1435	SCREW	1	
26	5292	SCREW	1	
27	210952	SPRING	1	
28	208447	POST NUT	1	
29	208448	SPRING BUSHING	1	
30	210940	SPRING	1	
31	204091	WASHER	1	
32	5082A	SCREW STUD	1	
33	210944	WASHER	1	
34	211613	GUIDE	1	
35	210938	LATCH	1	
36	5118	SCREW	1	
37	210939	SPRING	1	
38	205091	SHIRRING EDGE GUIDE	1	
39	1234	SCREW	2	
40	137906	WASHER	2	
41	210962	BRACKET/BINDER	1	
42	5210	SCREW	2	
43		BINDER	1	
44	1202	SCREW	2	
45	167066	WASHER	2	

Fabric Edge Guide

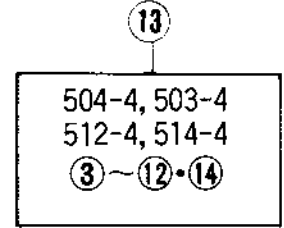
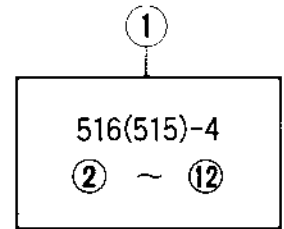
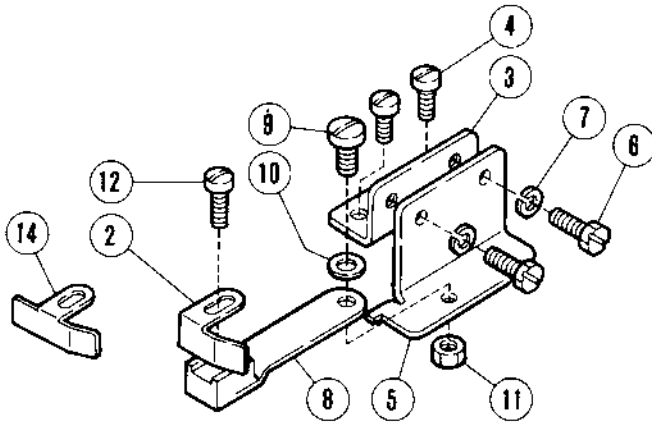

Cloth Guide

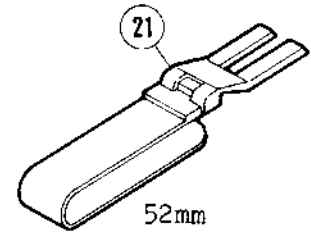
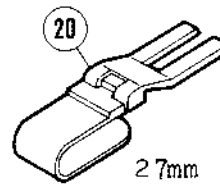
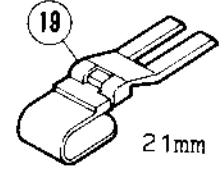
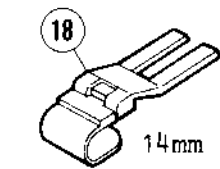
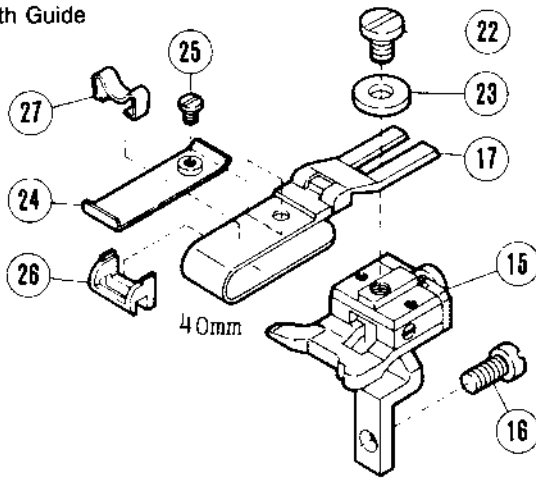

514-4

516(515)-4

Taping Foot

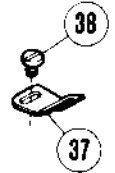
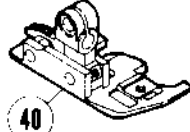
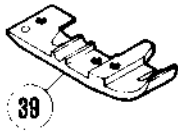

504-4, 503-4, 512-4, 514-4

Angled Upper Knife

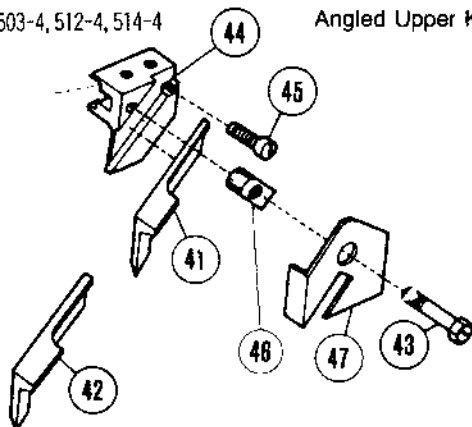

Taping Guides

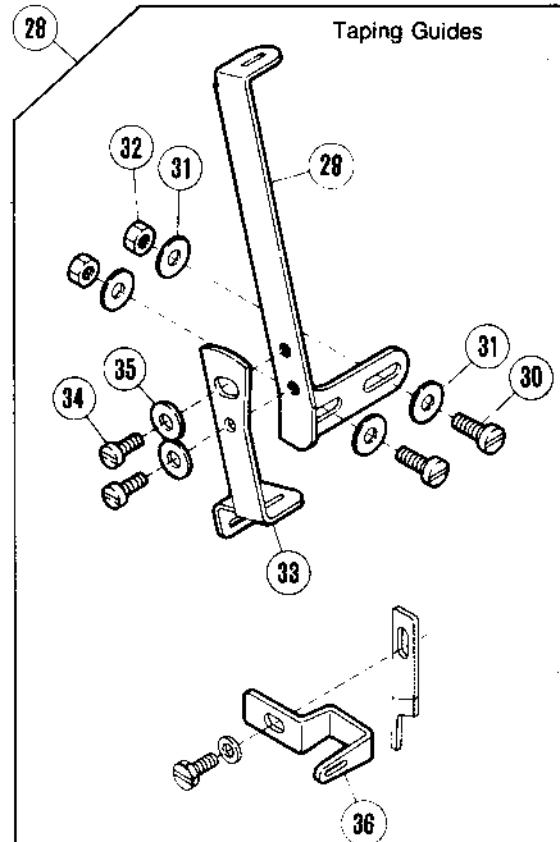

ATTACHMENT

REF. NO.	PART NO.	NAME	QT.	MEMO
1	204449	EDGE GUIDE COMPLETE	1	
2	201233A	EDGE GUIDE	1	
3	204451	BRACKET	1	
4	5117	SCREW	2	
5	204452	BRACKET/EDGE GUIDE	1	
6	2193	SCREW	2	
7	202286	SPRING WASHER	2	
8	201485	BRACKET/EDGE GUIDE	1	
9	5184	SCREW	1	
10	201191	SPRING	1	
11	3044	NUT	1	
12	1202	SCREW	1	
13	204896	BRACKET COMPLETE/EDGE GUIDE	1	
14	204667	EDGE GUIDE	1	
15	204760A	WELT GUIDE HOLDER	1	
16	1189	SCREW	1	
17	201211B	FOLDER COMPLETE (40MM)	1	
18	205457	FOLDER COMPLETE (14MM)	1	
19	205678	FOLDER COMPLETE (21MM)	1	
20	205679	FOLDER COMPLETE (27MM)	1	
21	205456	FOLDER COMPLETE (52MM)	1	
22	2905	SCREW	1	
23	137142	WASHER	1	
24	205835	AUXILIARY PLATE	1	
25	5299	SCREW	1	
26	303312A	REGULATOR	1	
27	303313	FLAT SPRING	1	
28	209402-91	TAPE GUIDE ASSEMBLY	1	
29	208915	TAPE GUIDE (UPPER)	1	
30	1175-3	SCREW	2	
31	137906	WASHER	4	
32	3091	NUT	2	
33	208916	TAPE GUIDE (LOWER)	1	
34	1216	SCREW	2	
35	137906	WASHER	2	
36	205319	TAPE TAKEUP	1	
37	208735	TAPE GUIDE	1	
38	1333	SCREW	1	
39	208730	PRESSER FOOT	1	
40	303688	PRESSER FOOT	1	
41	204152	UPPER KNIFE	1	
42	204835	UPPER KNIFE	1	
43	5371	SCREW	1	
44	204830	UPPER KNIFE CLAMP	1	
45	5142	SCREW	1	
46	204155	GIB	1	
47	204156	WASTE GUARD	1	

1	2	3	~	30	516(515)-4
31	32	3	~	30	504-4, 512-4 514-4

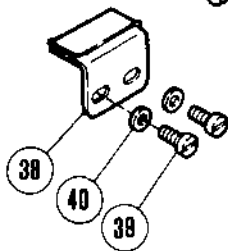
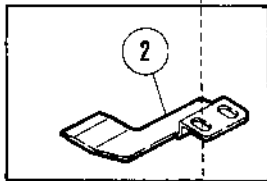
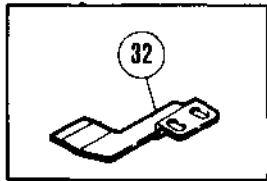
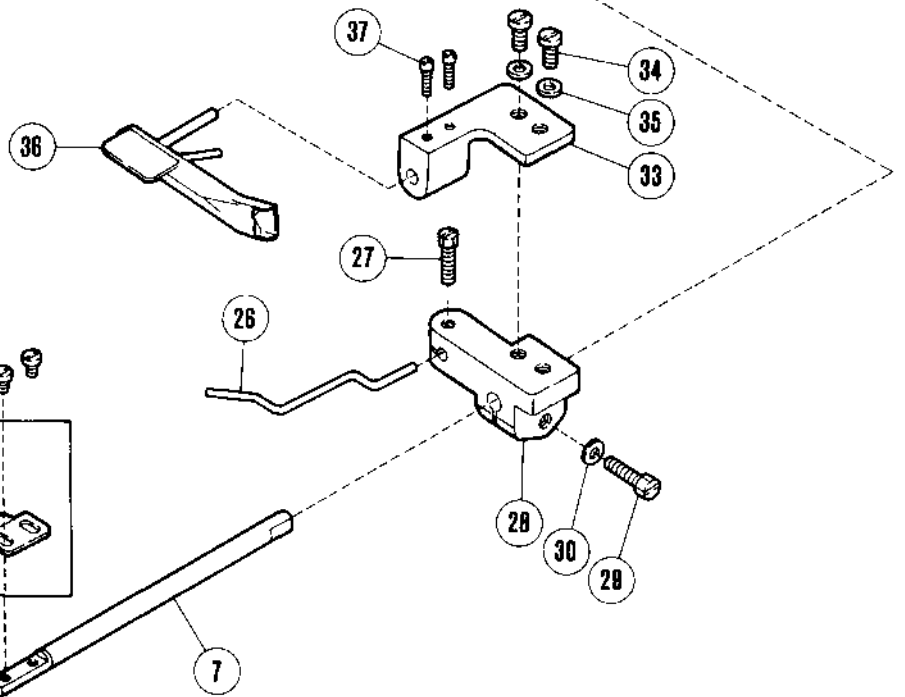
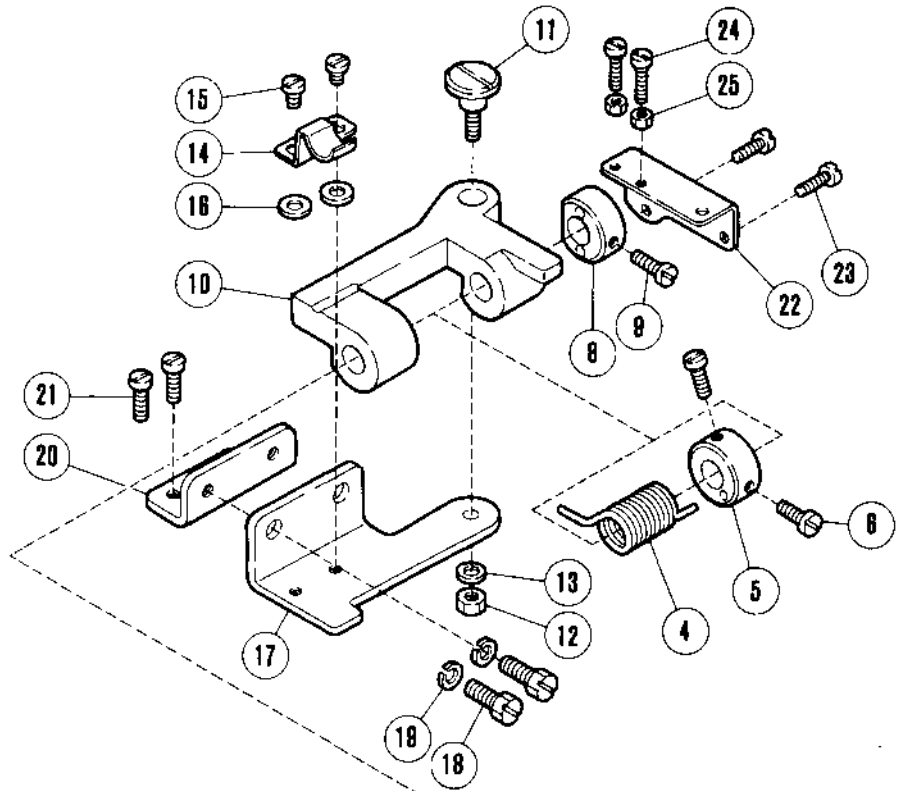

ATTACHMENT FOR SHIRRING (OPTION)

REF. NO.	PART NO.	NAME	QT.	MEMO
1	204670	SHIRRING ATTACHMENT COMPLETE	1	
2	205064	SHIRRING BLADE	1	
3	5227	SCREW	2	
4	205065	SPRING	1	
5	205066	COLLAR	1	
6	5064	SCREW	2	
7	205067	SHAFT	1	
8	205068	COLLAR	1	
9	2213	SCREW	1	
10	205069	BLOCK	1	
11	5326	SCREW	1	
12	5137	NUT	1	
13	202286	SPRING WASHER	1	
14	205070	FLAT SPRING	1	
15	1229	SCREW	2	
16	200183	WASHER	2	
17	204495	PLATE	1	
18	2193	SCREW	2	
19	202286	SPRING WASHER	2	
20	204451	BRACKET	1	
21	5117	SCREW	2	
22	205072	LEVER/PRESSER FOOT	1	
23	5117	SCREW	2	
24	1170	SCREW	2	
25	3091	NUT	2	
26	204592	LIFTER	1	
27	5118	SCREW	1	
28	205104	BLOCK	1	
29	5276	SCREW	1	
30	204585	WASHER	1	
31	204882	PRESSER FOOT COMPLETE	1	
32	205137	PRESSER FOOT	1	
33	205103	BRACKET/BINDER	1	
34	1175-3	SCREW	2	
35	167066	WASHER	2	
36		BINDER	1	
37	1170-1	SCREW	2	
38	205091	SHIRRING EDGE GUIDE	1	
39	1234	SCREW	2	
40	137906	WASHER	2	

Shirring attachment

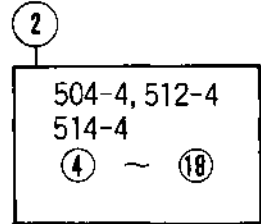
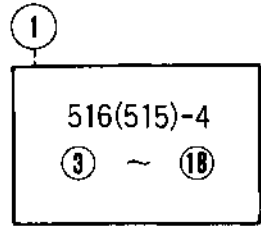
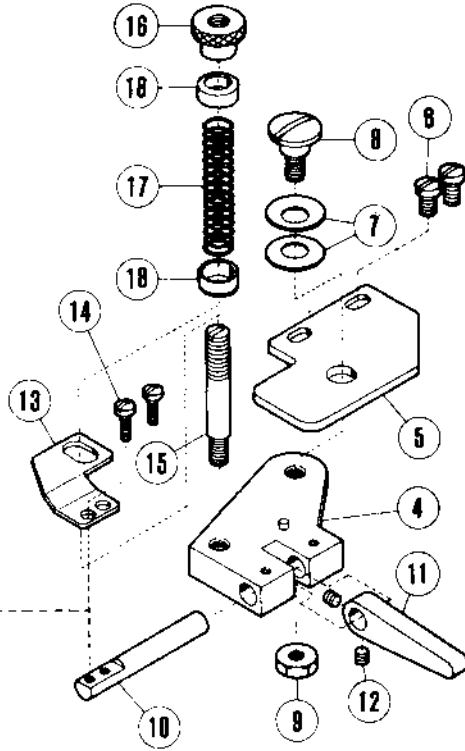
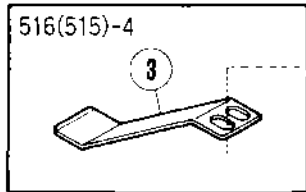
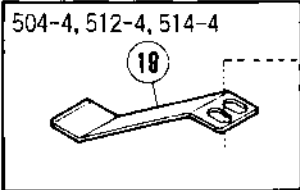

20

Knee Lifter

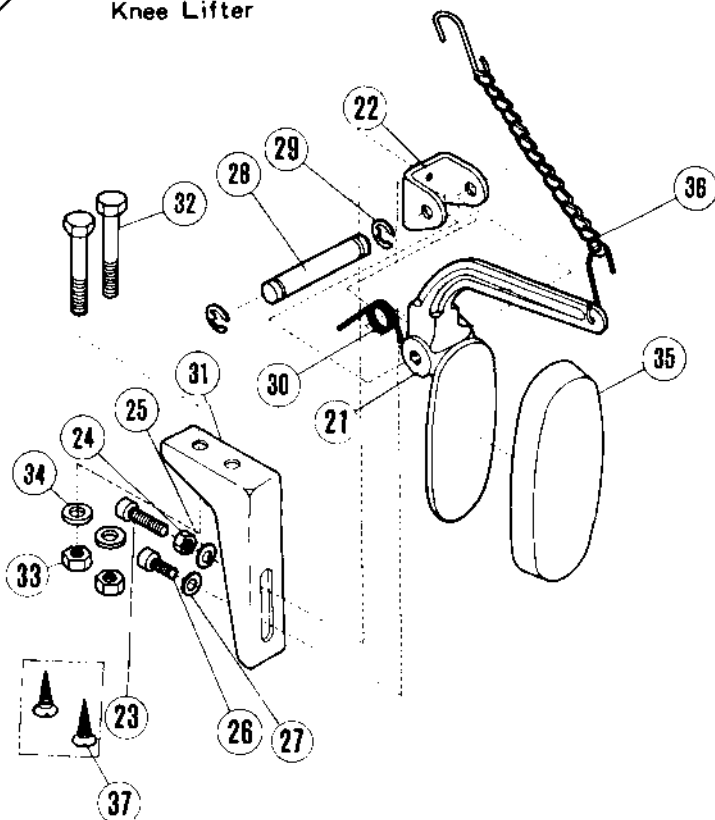

516(515)-4

Monofilament needle thread tension guide
(used for 401 needle thread of monofilament)

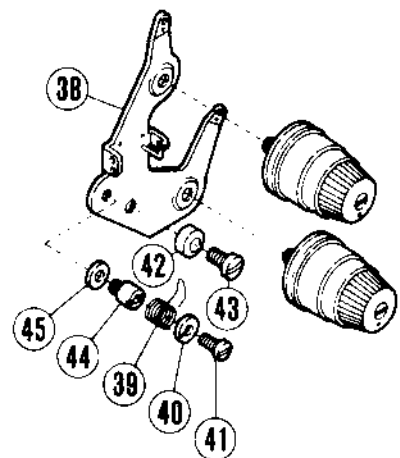

ATTACHMENT (OPTION)

REF. NO.	PART NO.	NAME	QT.	MEMO
1	204897	SHIRRING ATTACHMENT	1	
2	204898	SHIRRING ATTACHMENT	1	
3	204885	SHIRRING BLADE	1	
4	204886	BRACKET	1	
5	204887	BRACKET BASE	1	
6	5117	SCREW	2	
7	204888	SPRING	2	
8	5380	SCREW	1	
9	5104	NUT	1	
10	204889	SHIRRING BLADE SHAFT	1	
11	204890	LEVER	1	
12	1459	SCREW	2	
13	204891	BLADE GUIDE	1	
14	1175-2	SCREW	2	
15	204892	POST	1	
16	204893	THUMB NUT	1	
17	204894	SPRING	1	
18	204895	CUP	2	
19	204966	PRESSER FOOT	1	
20	192	KNEE CONTROLLER ASSEMBLY	1	
21	193	KNEE CONTROLLER	1	
22	194	HINGE	1	
23	5183	SCREW	1	
24	3044	NUT	1	
25	137142	WASHER	1	
26	5118	SCREW	1	
27	137142	WASHER	1	
28	195	PIN	1	
29	202522	RING	1	
30	196	SPRING	1	
31	197	BRACKET	1	
32	5347	SCREW	2	
33	5348	NUT	2	
34	204585	WASHER	2	
35	198	RUBBER PAD	1	
36	199	CHAIN	1	
37	5341	SCREW	2	
38	208484	THREAD TENSION BRACKET COM.	1	
39	204960	SPRING	1	
40	204962	NUT	1	
41	2922	SCREW	1	
42	202683	STOPPER	1	
43	5117	SCREW	1	
44	204961	STUD	1	
45	202757	WASHER	1	

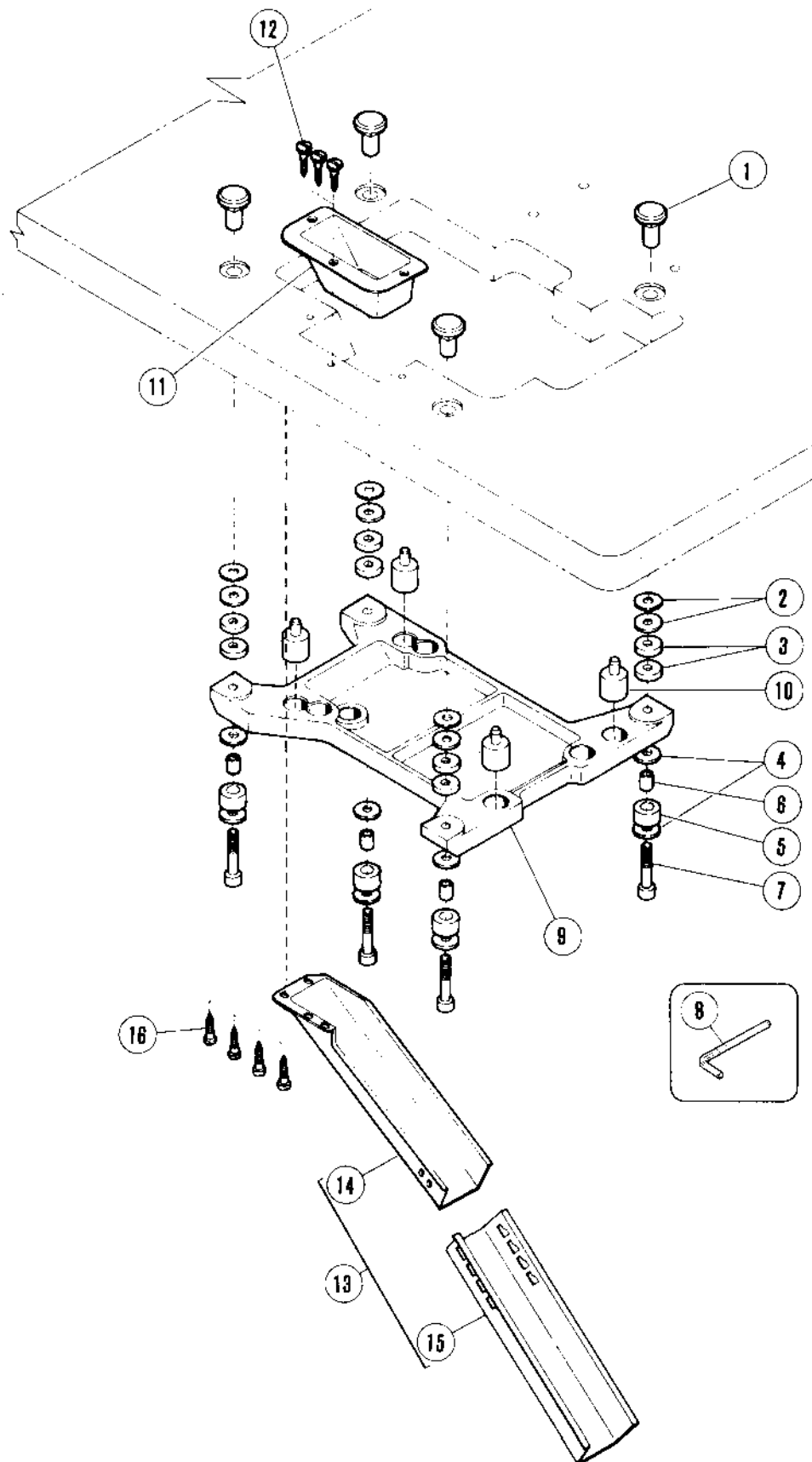

PARTS FOR SEMI-SUBMERGED INSTALLATION

REF. NO.	PART NO.	NAME	QT.	MEMO
1	206336	NUT	4	
2	206337	WASHER	8	
3	205467	SPACER	8	
4	206337	WASHER	4	
5	205764	CUSHION RUBBER	4	
6	205765	LINER	4	
7	4512	SCREW	4	
8	272	ALLEN KEY/6MM	1	
9	205466	MACHINE REST BOARD	1	
10	205473	CUSHION RUBBER	4	
11	205470-JA	WASTE CHUTE TOP	1	
12	4904	SCREW	3	
13	9050	WASTE CHUTE SET	1	
14	205468-JA	WASTE CHUTE TOP (A)	1	
15	205469-JA	WASTE CHUTE TOP (B)	1	
16	4905	SCREW	4	

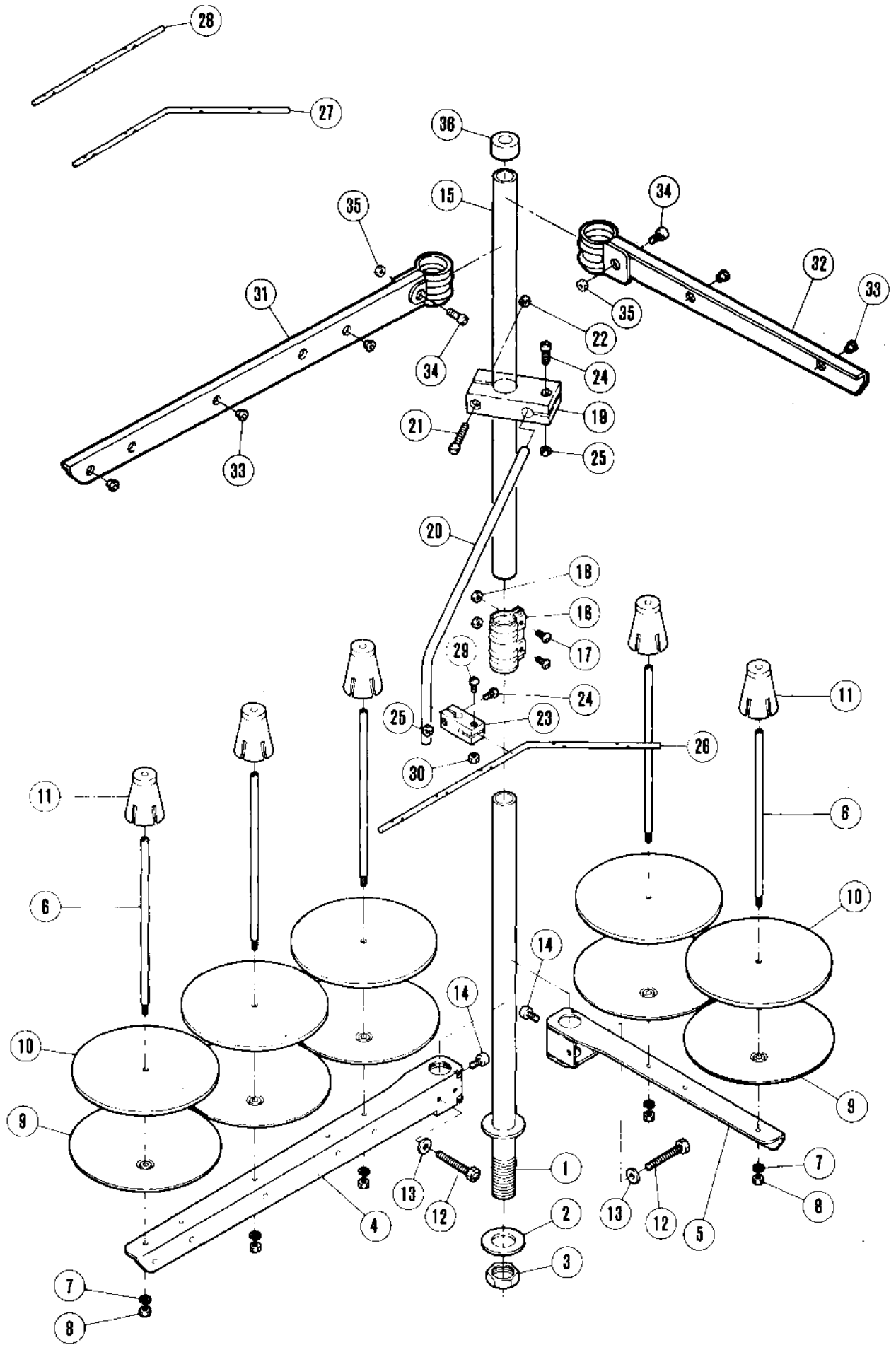

THREAD STAND

REF. NO.	PART NO. 部品番号	NAME	SPOOLS: 3	4	5	MEMO
	486A9C	THREAD STAND ASS. (5-SPOOLS)			1	
	486B9C	THREAD STAND ASS. (4-SPOOLS)		1		
	486C9C	THREAD STAND ASS. (3-SPOOLS)	1			
1	503-CA	THREAD STAND ROD (LOWER)	1	1	1	
2	509	WASHER	1	1	1	
3	5476	NUT	1	1	1	
4	505-CA	BRACKET	1		1	
5	505ACA	BRACKET		2	1	
6	380A	SPOOL PIN	3	4	5	
7	201252	SPRING WASHER	3	4	5	
8	4803	NUT	3	4	5	
9	381-CA	SPOOL TRAY	3	4	5	
10	507	CUSHION	3	4	5	
11	382-CA	SPOOL RETAINING FIN	3	4	5	
12	7102	SCREW	1	2	2	
13	512	WASHER	1	2	2	
14	4022	SCREW	1	2	2	
15	502-CA	THREAD STAND ROD (UPPER)	1	1	1	
16	504-CA	JOINT	1	1	1	
17	4021	SCREW	2	2	2	
18	4805	NUT	2	2	2	
19	383-CA	BRACKET	1	1	1	
20	384	THREAD GUIDE BAR ROD	1	1	1	
21	4014	SCREW	1	1	1	
22	4803	NUT	1	1	1	
23	233-CA	HOLDER	1	1	1	
24	4012	SCREW	2	2	2	
25	4803	NUT	2	2	2	
26	293A	THREAD GUIDE BAR (5-SPOOLS)			1	
27	293B	THREAD GUIDE BAR (4-SPOOLS)		1		
28	293C	THREAD GUIDE BAR (3-SPOOLS)	1			
29	4012	SCREW	1	1	1	
30	4803	NUT	1	1	1	
31	527-CA	BRACKET	1		1	
32	527ACA	BRACKET		2	1	
33	506	THREAD EYELET	3	4	5	
34	4117	SCREW	1	2	2	
35	4805	NUT	1	2	2	
36	386	ROD CAP	1	1	1	

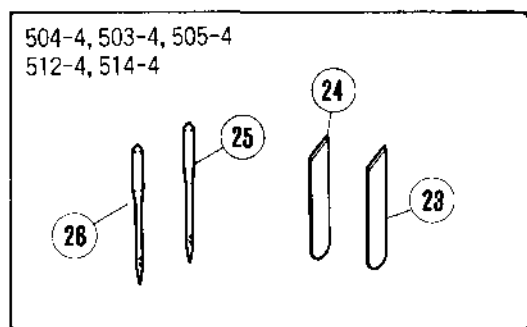
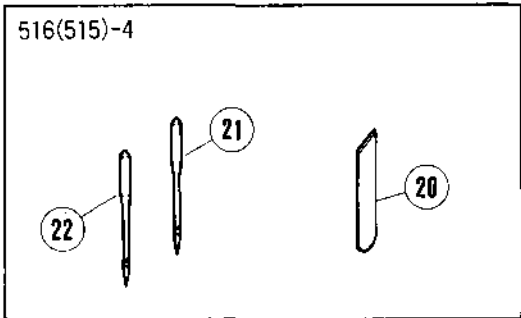
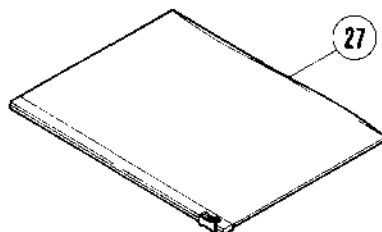
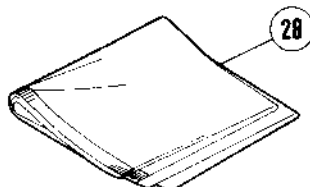
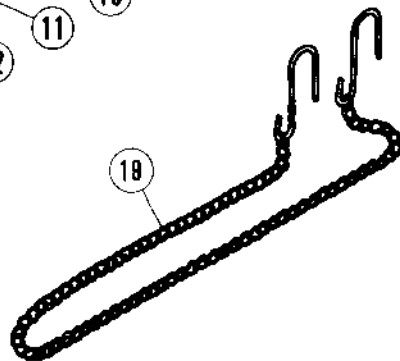
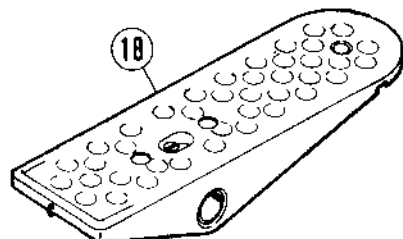
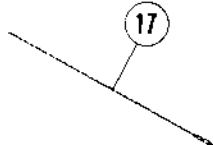
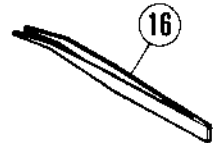
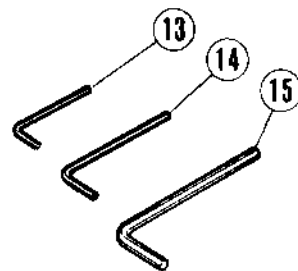
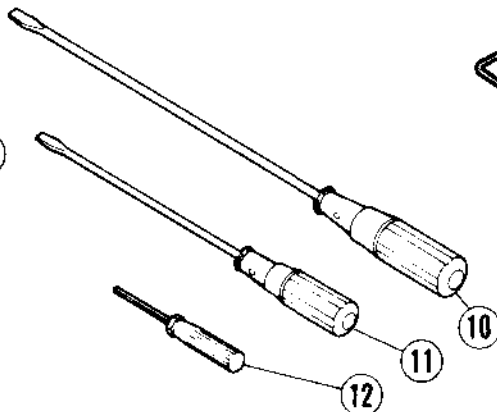
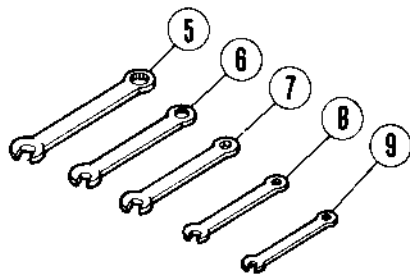
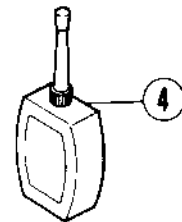
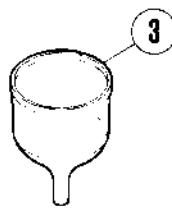
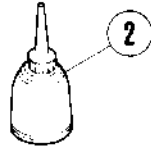
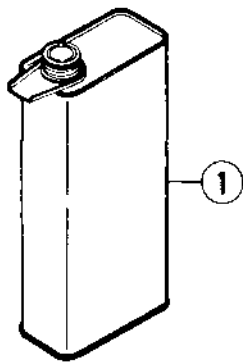

ACCESSORIES

REF. NO.	PART NO.	NAME	MEMO
1	452	OIL CONTAINER/750CC	
2	485	OILER	
3	484	OIL FUNNEL	
4	178	CONTAINER - SILICONE	
5	286	WRENCH/9.5MM	
6	285	WRENCH/8MM	
7	284	WRENCH/7MM	
8	283	WRENCH/6MM	
9	391	WRENCH/5MM	
10	127	SCREWDRIVER (LARGE)	
11	128	SCREWDRIVER (MEDIUM)	
12	179	ALLEN KEY DRIVER	
13	322	ALLEN KEY/2.38MM	
14	182	ALLEN KEY	
15	200	ALLEN KEY/4.76MM	
16	131	TWEEZERS	
17	153	THREADING WIRE	
18	480	PEDAL	
19	392	CHAIN	
20	204161	LOWER KNIFE	
21	DCX27	NEEDLE	
22	DCX27	NEEDLE	
23	201127	LOWER KNIFE/THIN	
24	202295	LOWER KNIFE/THICK	
25	DCX27	NEEDLE	
26	DCX3	NEEDLE	
27	482	ACCESSORY BAG	
28	909	DUST COVER	

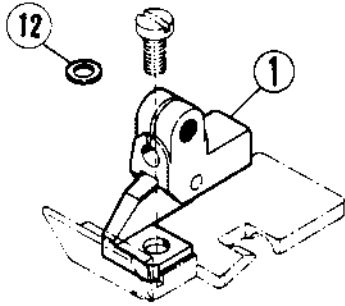

NG = Needle Gauge
 CD = Cord Diameter

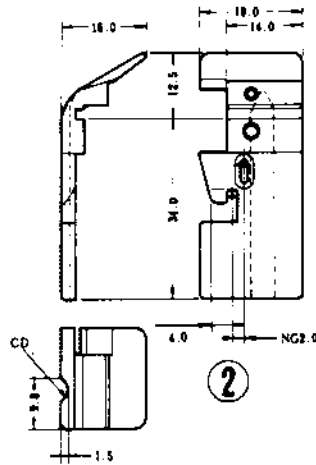

NG x CD
 2 x 3 204499
 2 x 4 204500
 2 x 5 204501

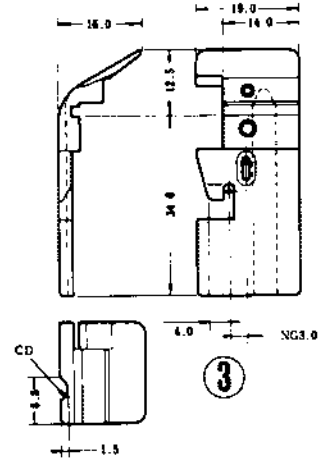

NG x CD
 3 x 3 204502
 3 x 4 204503
 3 x 5 204504

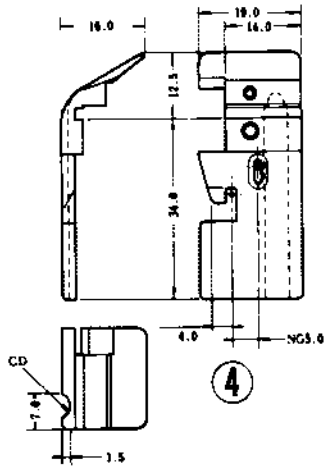

NG x CD
 5 x 3 204505
 5 x 4 204506
 5 x 5 204507

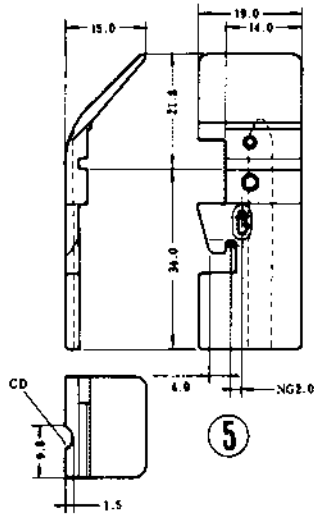

NG x CD
 2 x 3 204508
 2 x 4 204509
 2 x 5 204510

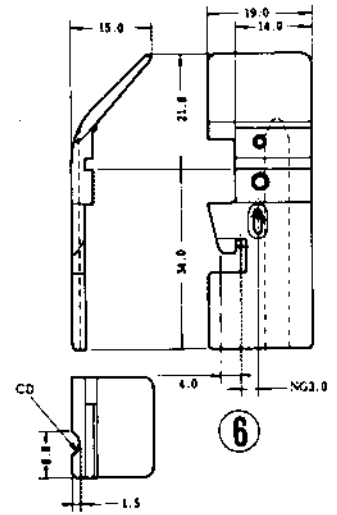

NG x CD
 3 x 3 204511
 3 x 4 204512
 3 x 5 204513

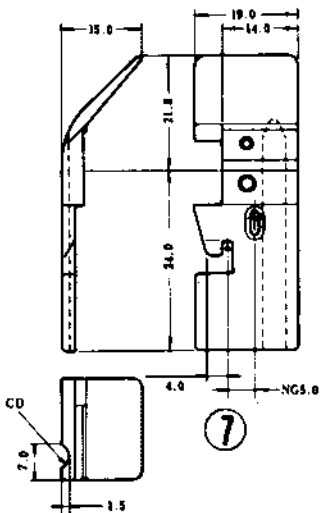

NG x CD
 5 x 3 204514
 5 x 4 204515
 5 x 5 204516

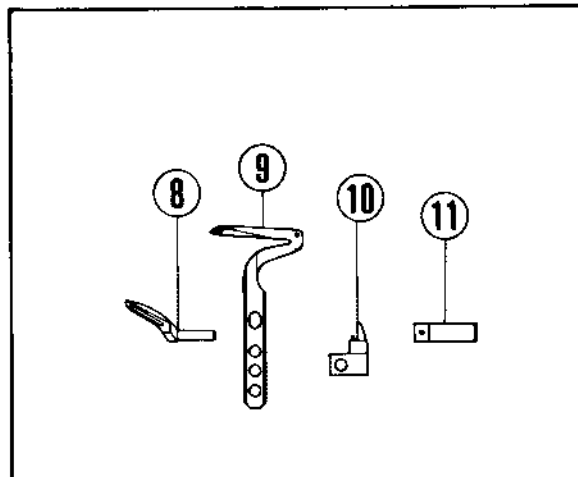

PIPING FOOT-OTHERS

REF. NO.	PART NO.	NAME	QT.	MEMO
1	208554	BRACKET COMPLETE	1	
2	204499	PIPING FOOT	1	
2	204500	PIPING FOOT	1	
2	204501	PIPING FOOT	1	
3	204502	PIPING FOOT	1	
3	204503	PIPING FOOT	1	
3	204504	PIPING FOOT	1	
4	204505	PIPING FOOT	1	
4	204506	PIPING FOOT	1	
4	204507	PIPING FOOT	1	
5	204508	PIPING FOOT	1	
5	204509	PIPING FOOT	1	
5	204510	PIPING FOOT	1	
6	204511	PIPING FOOT	1	
6	204512	PIPING FOOT	1	
6	204513	PIPING FOOT	1	
7	204514	PIPING FOOT	1	
7	204515	PIPING FOOT	1	
7	204516	PIPING FOOT	1	
8	204990	UPPER LOOPER	1	
9	204991	LOWER LOOPER	1	
10	204906	PRESSER FOOT FINGER	1	
11	202281	WELT GUIDE EXTENSION/TRICOT	1	
12	202875	WASHER	1	

**GAUGE PARTS
CONSTRUCTION CHART**

Feed pattern : 2N(2-row narrow)

**516 (515) -4/27, 29, 32
516-4/550**

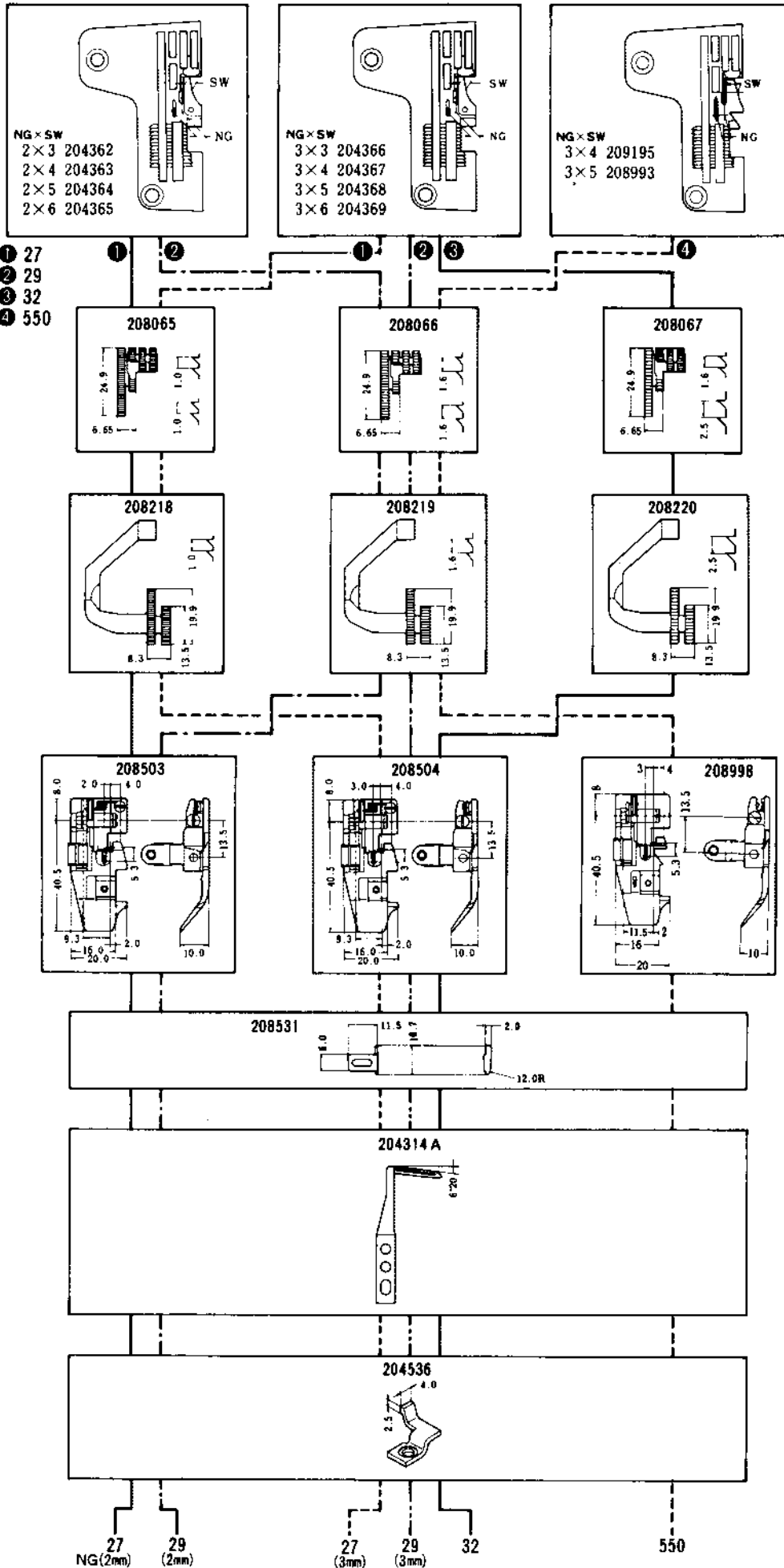

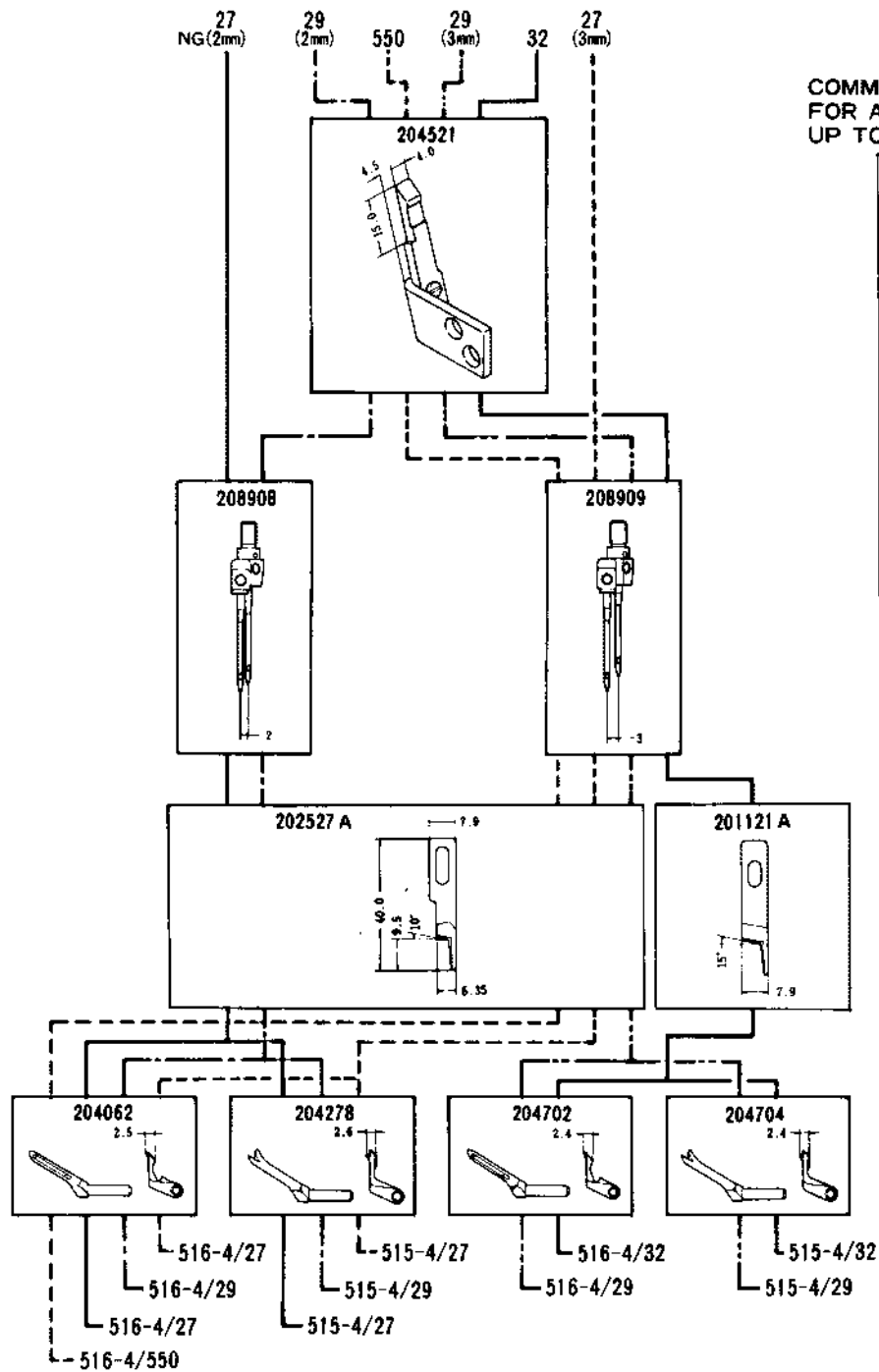

COMMON GAUGE PARTS
FOR ALL MACHINE TYPES
UP TO PAGE 89

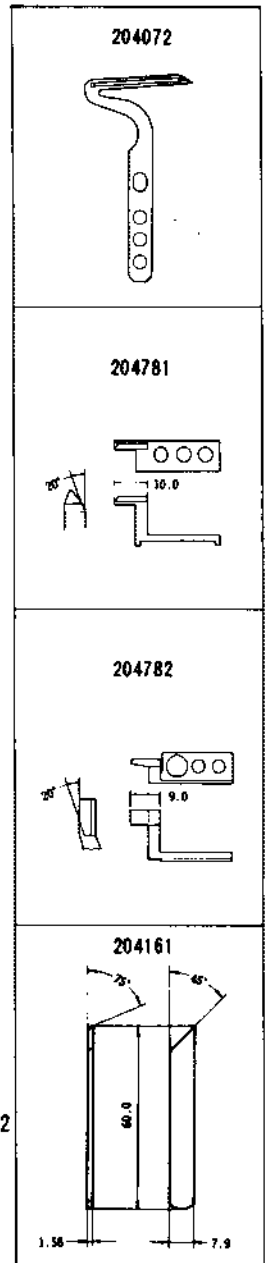

				MEMO	
516(515) -4/27	2	3, 4, 5, 6	0.6~2		Fine tooth pitch makes this ideal for seaming on permapress fabrics, nylon linings etc.
	3	3, 4, 5, 6	0.6~2		
516(515) -4/29	2	3, 4, 5, 6	0.6~2		For general seaming on woven or knit fabrics such as slacks, pajamas, shirts, sweatpants etc.
	3	3, 4, 5, 6	0.6~2		
516(515) -4/32	3	3, 4, 5, 6	0.6~2		For seaming on heavyweight materials.
516-4/550	3	4, 5	0.7~2		Fitted with a binding attachment to insert a tape inside seam. Ensures high quality results.

**GAUGE PARTS
CONSTRUCTION CHART**

516 (515) -4/28, 26, 33, 52

Feed pattern : 2W(2-row wide)

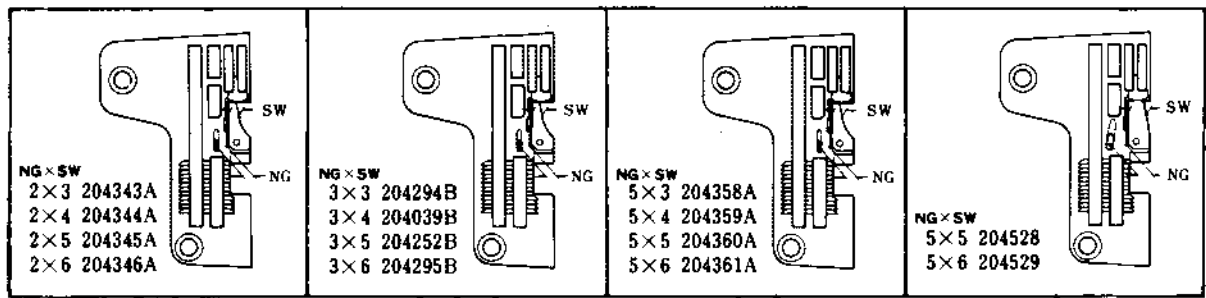



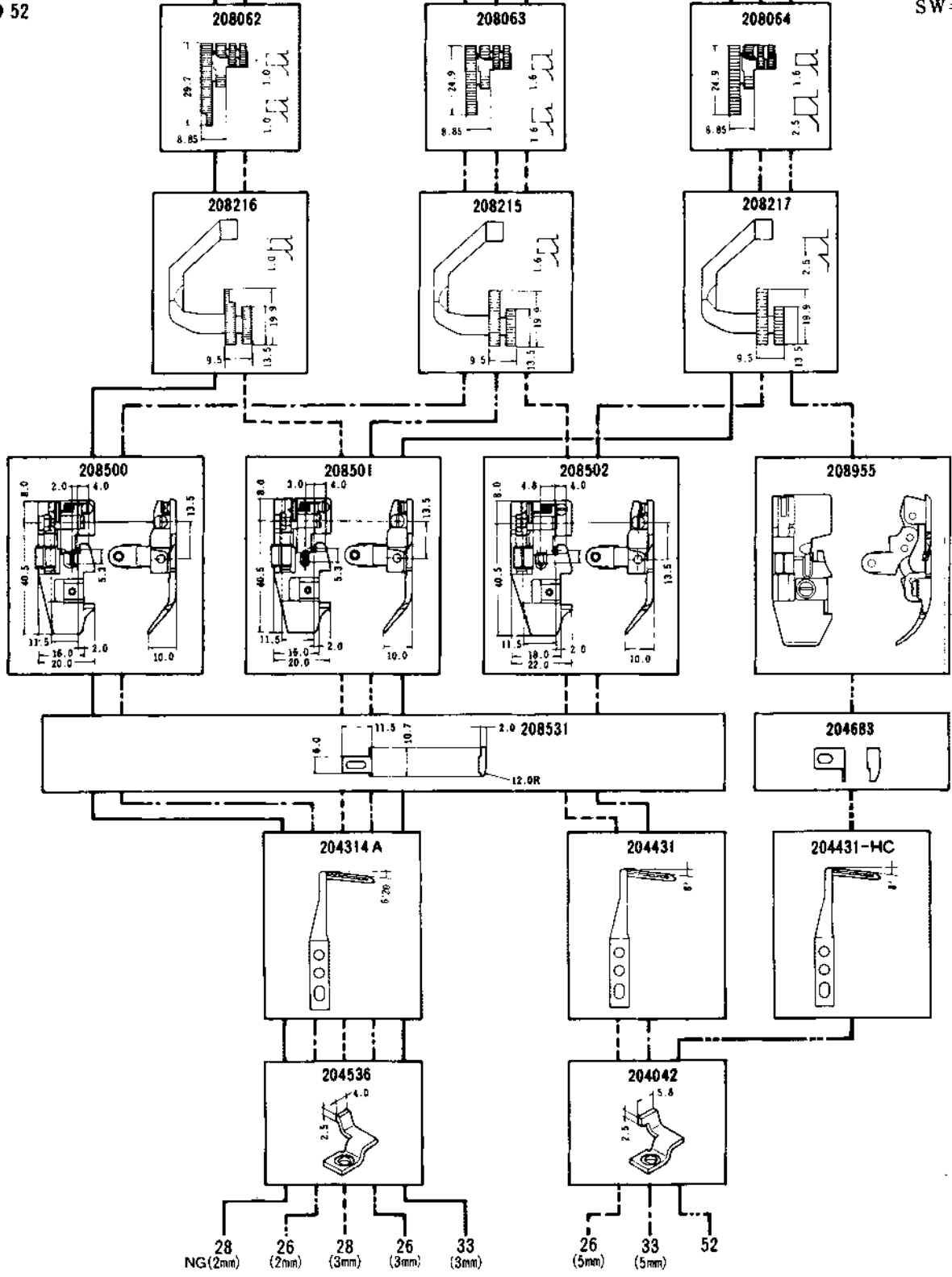

- ① 28
- ② 26
- ③ 33
- ④ 52

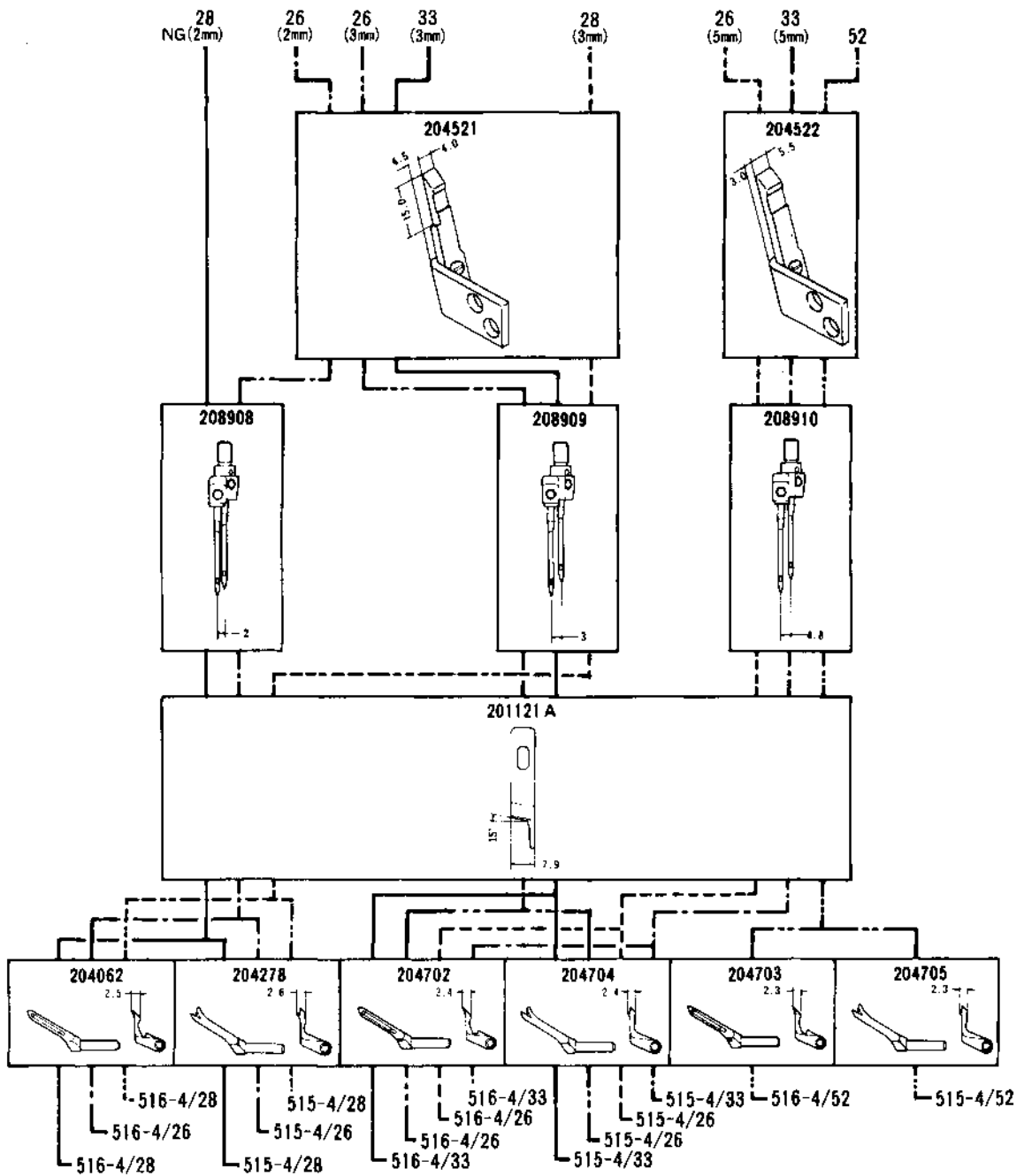
NG=Needle Gauge
SW=Seam Width





				MEMO	
516(515) -4/28	2	3, 4, 5, 6	0.6~2		Fine tooth pitch makes this ideal for seaming on permapress fabrics, nylon linings etc.
	3	3, 4, 5, 6	0.6~2		
516(515) -4/26	2	3, 4, 5, 6	0.6~2		For general seaming on woven or knit fabrics such as slacks, pajamas, shirts, sweatpants etc.
	3	3, 4, 5, 6	0.6~2		
	5	3, 4, 5, 6	0.6~2		
516(515) -4/33	3	3, 4, 5, 6	0.6~2		For seaming on heavyweight materials.
	5	3, 4, 5, 6	0.6~2		
516(515) -4/52	5	5, 6	0.6~2		Fitted with caterpillar foot for trouble-free seaming on jeans, workwear etc.



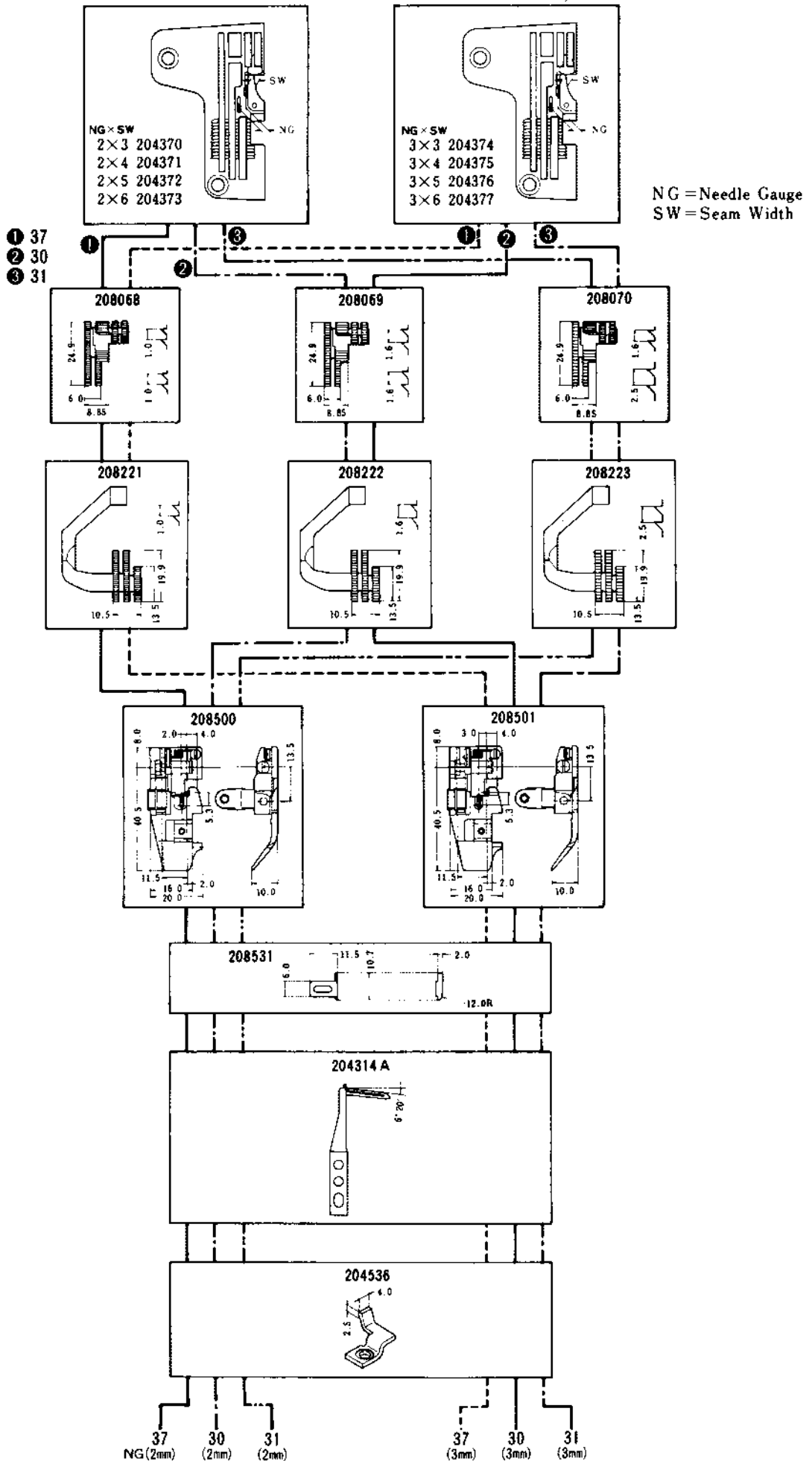

**GAUGE PARTS
CONSTRUCTION CHART**

516 (515) -4/37, 30, 31 (NG=2mm·3mm)

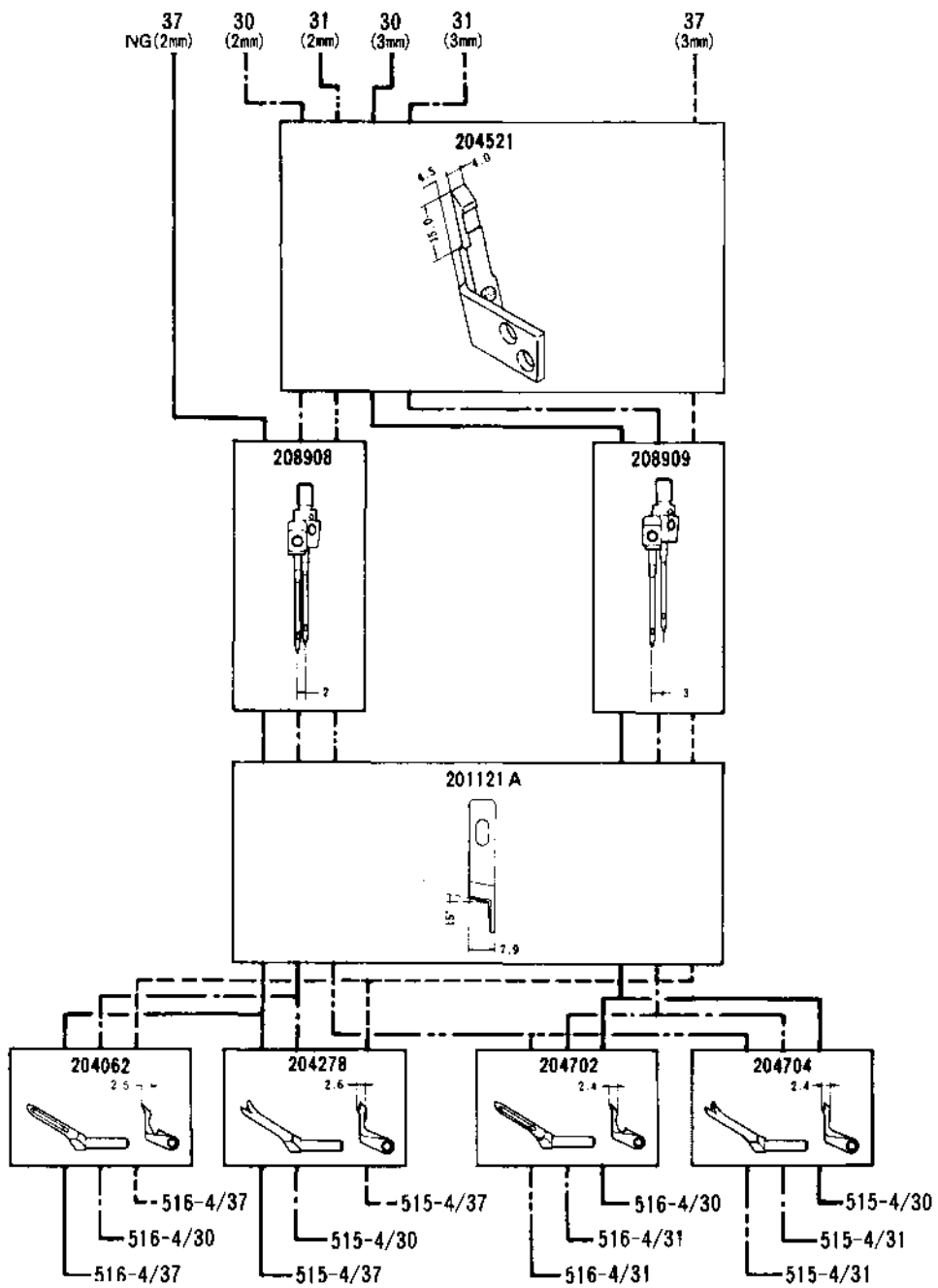
Feed pattern : 3W(3-row wide)





				MEMO	
516(515) -4/37	2	3, 4, 5, 6	0.6-2		Fine tooth pitch makes this ideal for seaming on permapress fabrics, nylon linings etc.
	3	3, 4, 5, 6	0.6-2		
516(515) -4/30	2	3, 4, 5, 6	0.6-2		For general seaming on woven or knit fabrics such as slacks, pajamas, shirts, sweatpants etc.
	3	3, 4, 5, 6	0.6-2		
516(515) -4/31	2	3, 4, 5, 6	0.6-2		For seaming on heavyweight materials.
	3	3, 4, 5, 6	0.6-2		



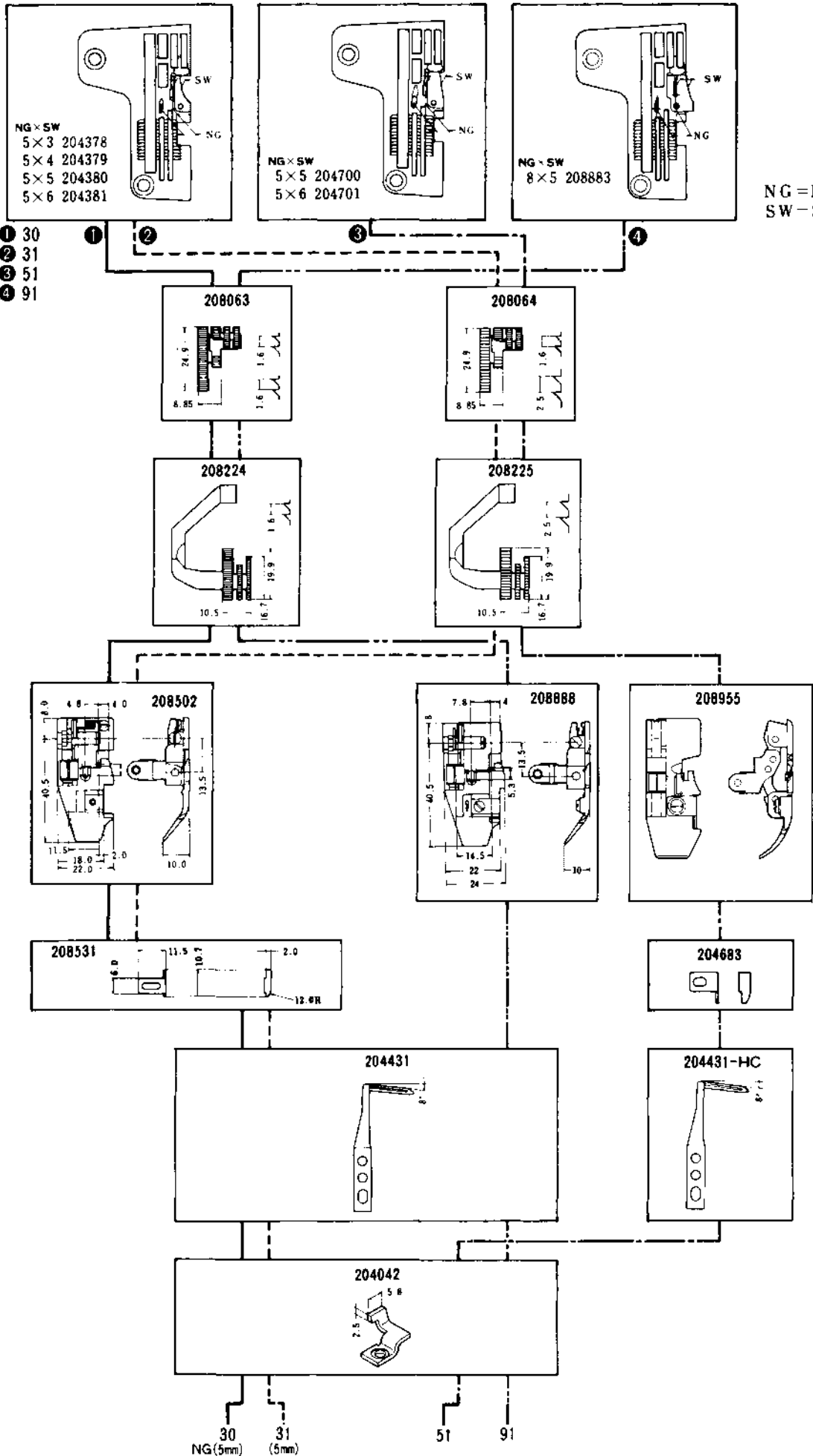

**GAUGE PARTS
CONSTRUCTION CHART**

Feed pattern : 3W(3-row wide)

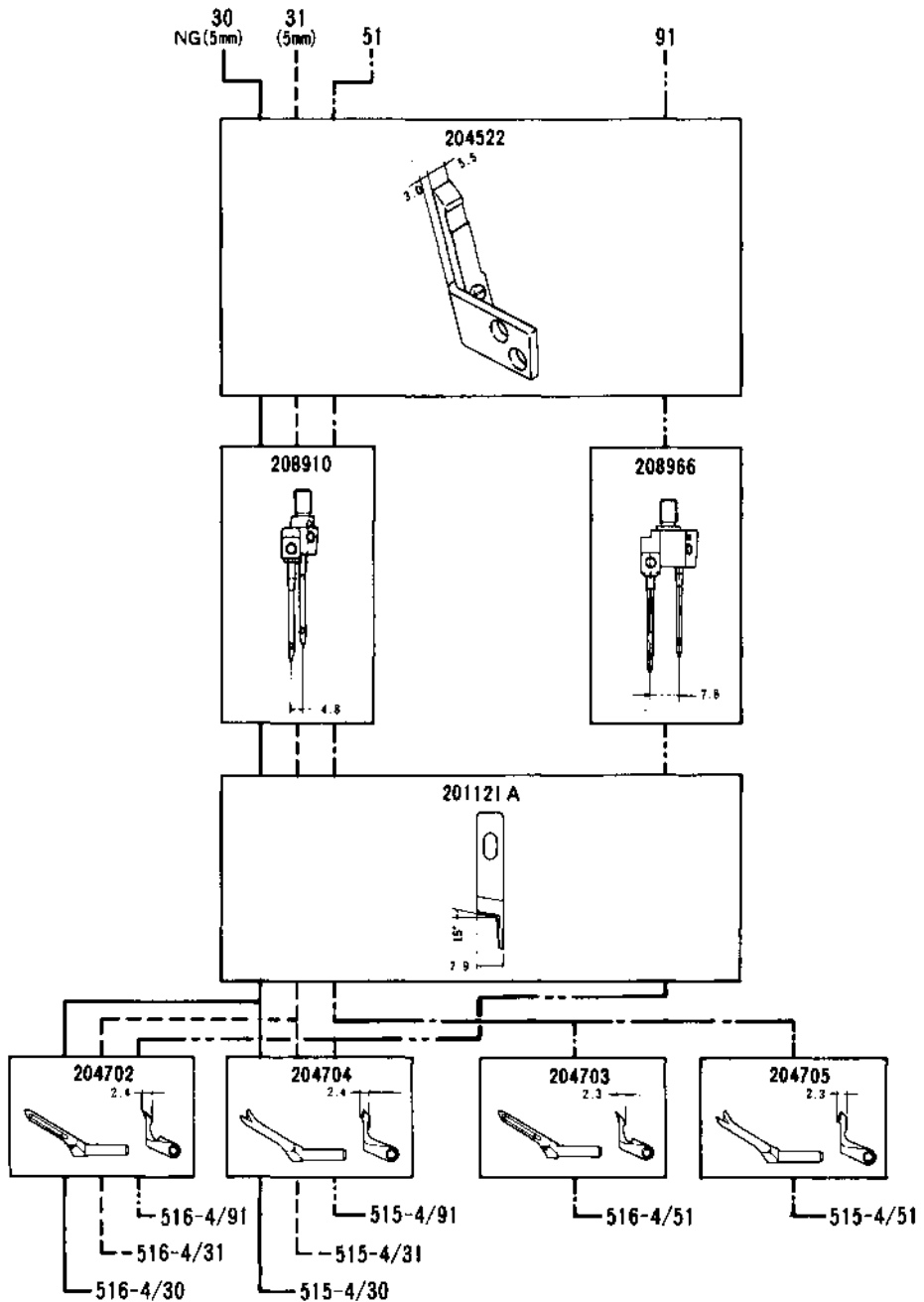
516(515)-4/30, 31 (NG=5mm)
516(515)-4/51, 91







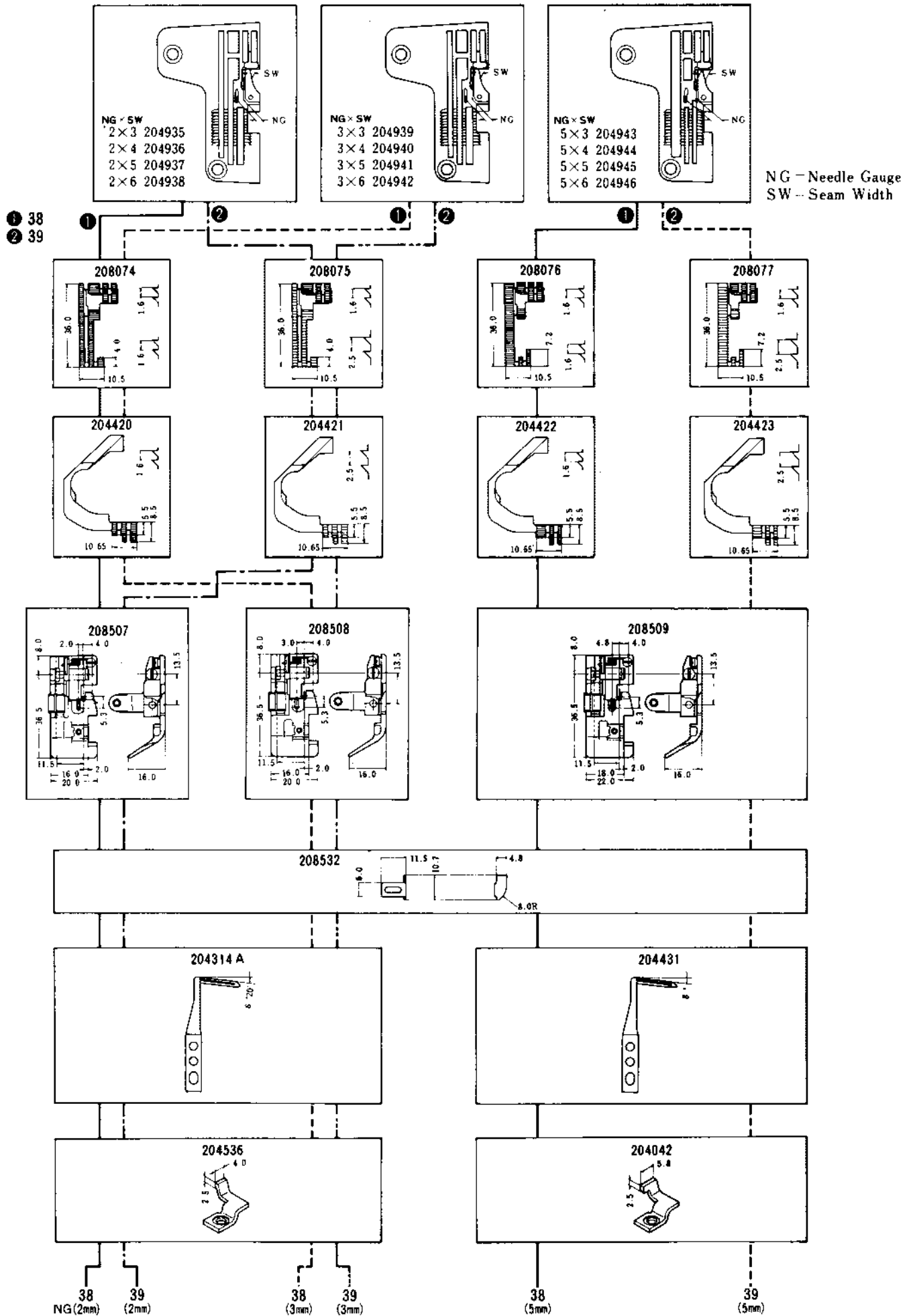

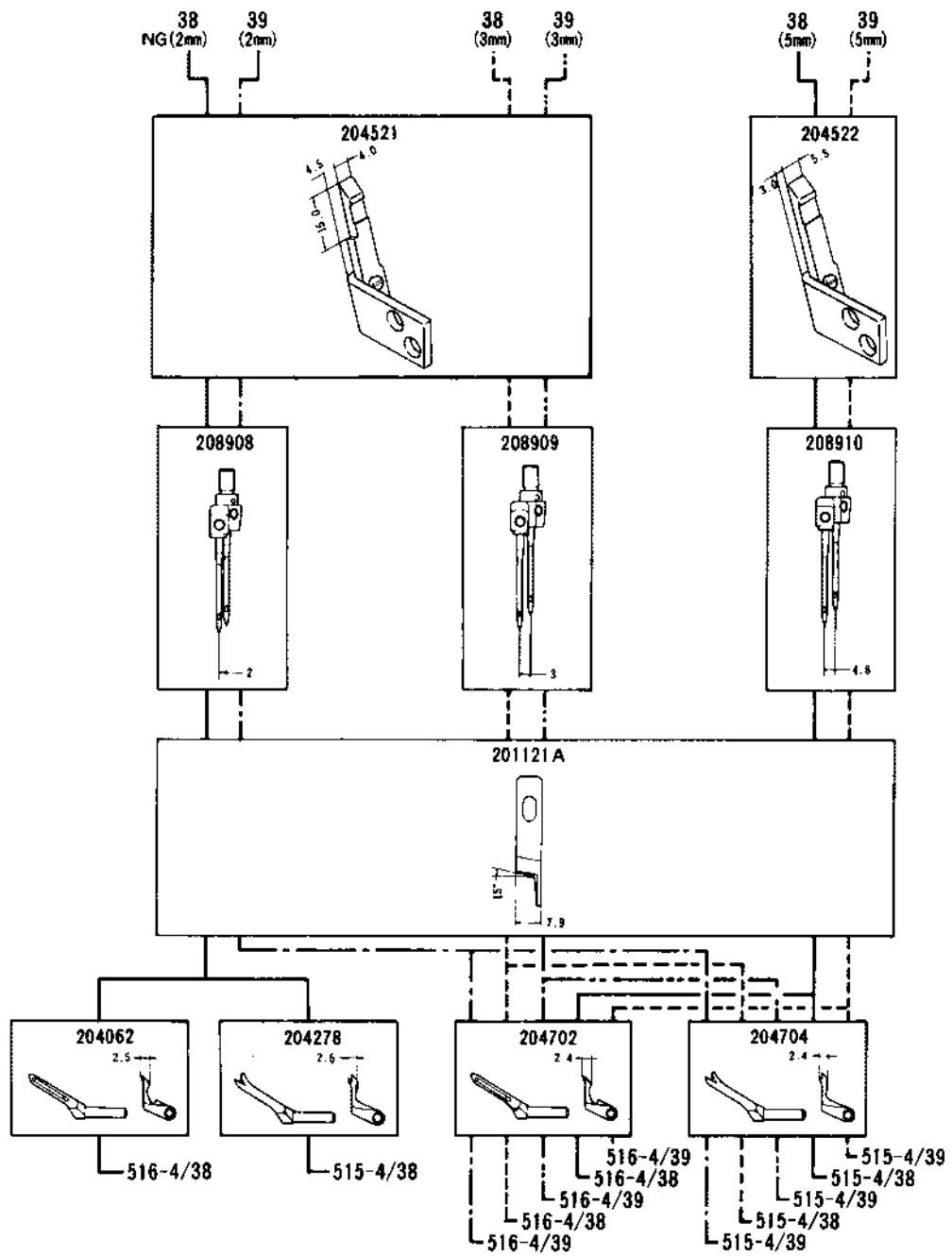
				MEMO	
516(515) -4/30	5	3, 4, 5, 6	0.6~2		For general seaming on woven or knit fabrics such as slacks, pajamas, shirts, sweatpants etc.
516(515) -4/31	5	3, 4, 5, 6	0.6~2		For seaming on heavyweight materials.
516(515) -4/51	5	5, 6	0.6~2		Fitted with caterpillar foot for trouble-free seaming on jeans, workwear etc.
516(515) -4/91	8	5	0.6~2		Extra wide needle gauge. Seaming on light to medium woven or knit fabrics such as blouse.





				MEMO	
516(515) -4/38	2	3,4,5,6	1~3		For intermittent shirring on light to medium weight materials such as negligee, curtains etc.
	3	3,4,5,6	1~3		
	5	3,4,5,6	1~3		
516(515) -4/39	2	3,4,5,6	1~3		For intermittent shirring on heavy weight materials such as curtains, bed spreaders, gowns etc.
	3	3,4,5,6	1~3		
	5	3,4,5,6	1~3		

**GAUGE PARTS
CONSTRUCTION CHART**

Feed pattern : 2W(2-row wide)

516-4/551

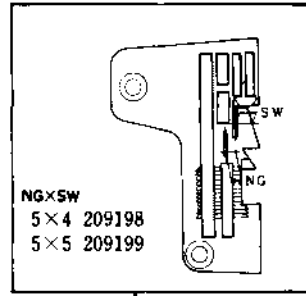
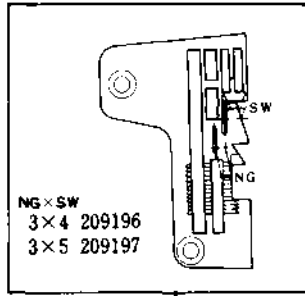

NG = Needle Gauge
SW = Seam Width

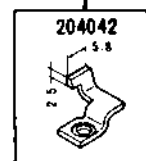
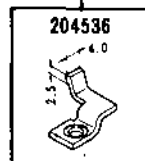
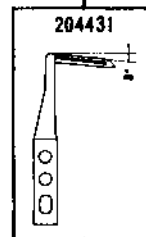
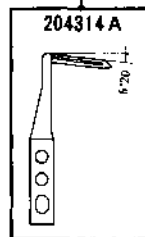
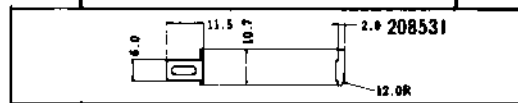
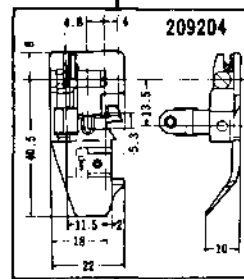
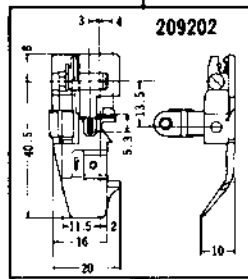
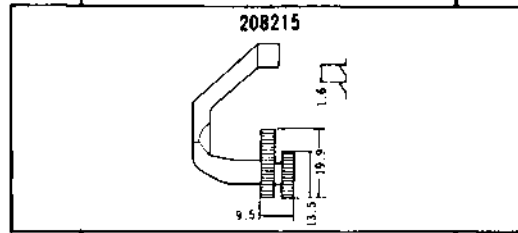
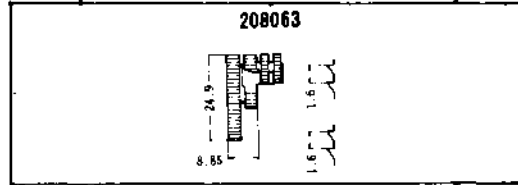

551
NG (3mm)

551
(5mm)

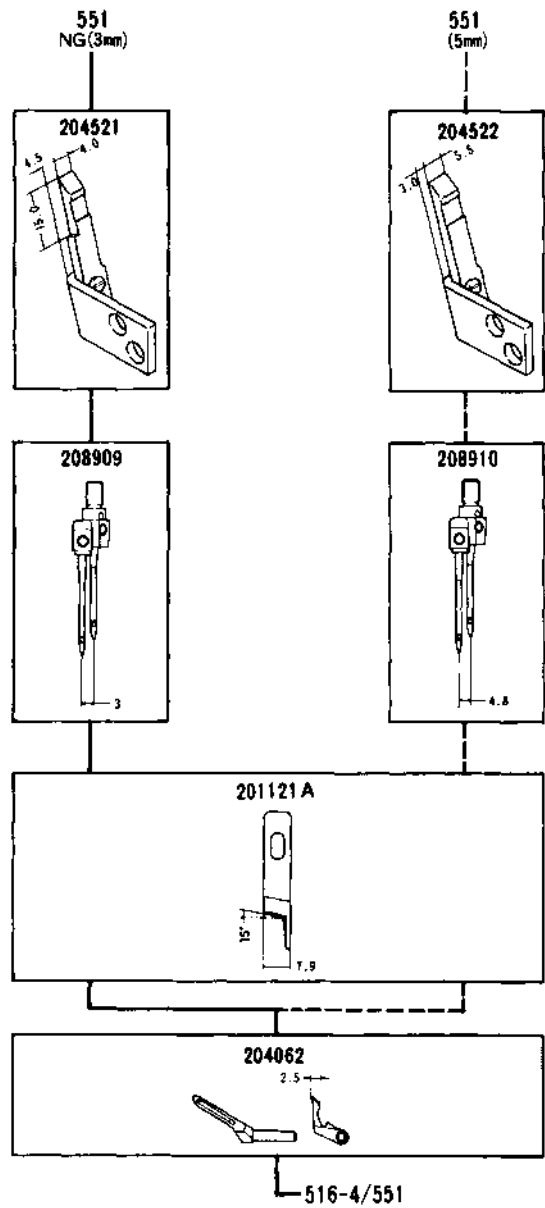

				MEMO	
516-4/551	3 5	4,5	0.7~2		Fitted with a binding attachment to insert a tape inside seam. Ensures high quality results.

**GAUGE PARTS
CONSTRUCTION CHART**

Feed pattern : 3W (3-row wide)

516-4/38P1 (P2)

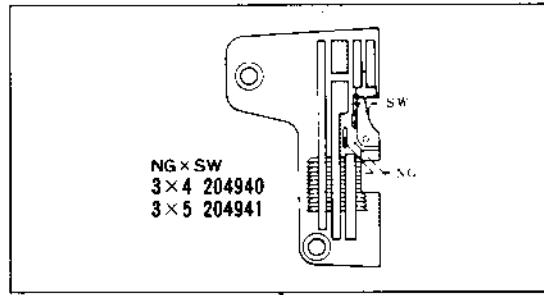



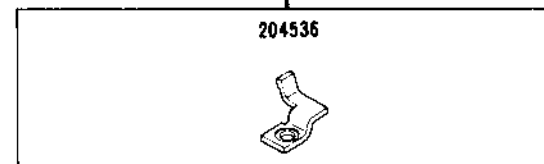
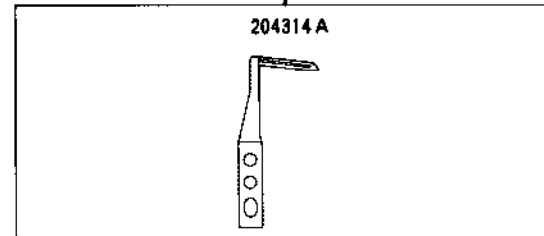
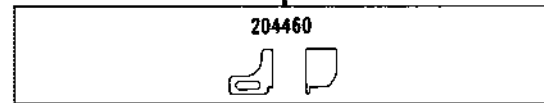
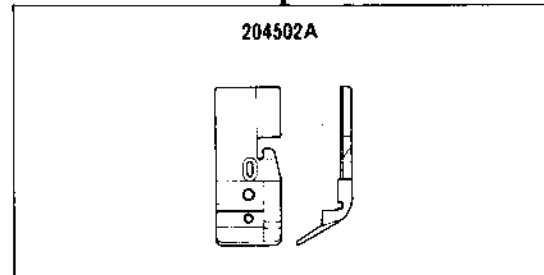
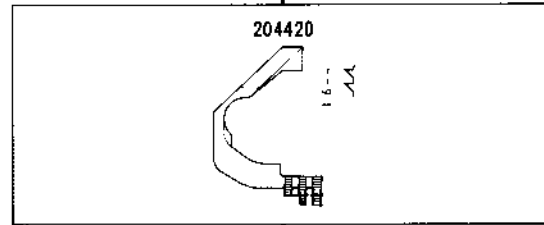
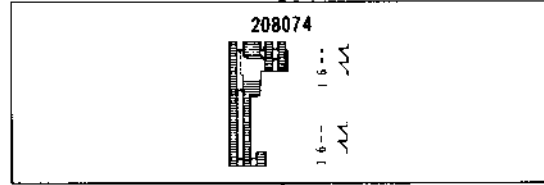

NG = Needle Gauge
SW = Seam Width

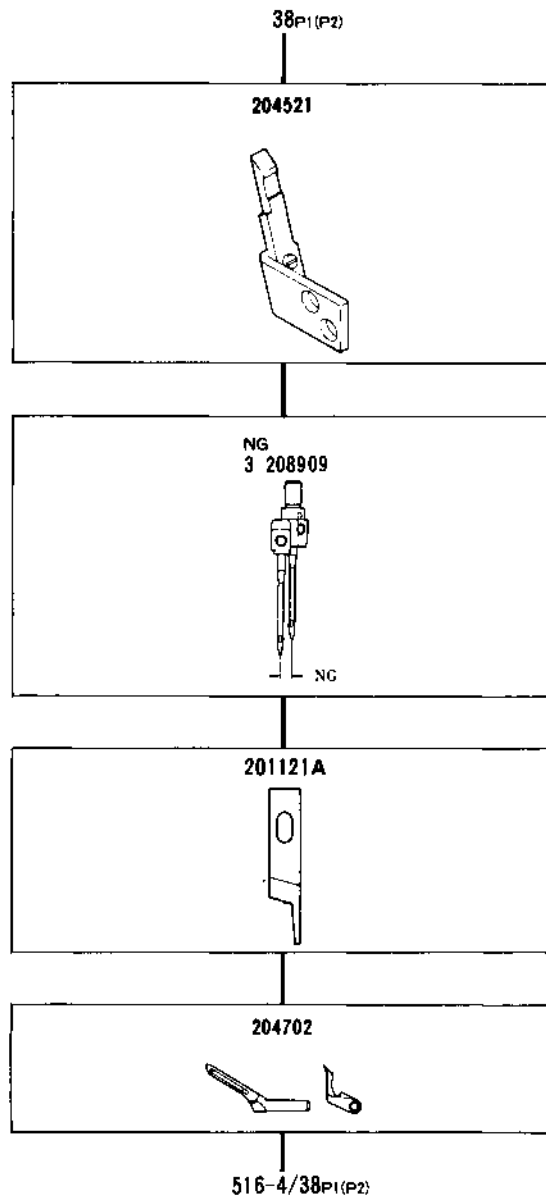

38P1 (P2)



				MEMO	
516-4/38P1	3	4,5	1 ~ 3		For shirring/piping on light to medium weight fabrics such as knit shirts, sweat pants, pajamas, womens' and kids' clothes.
516-4/38P2					

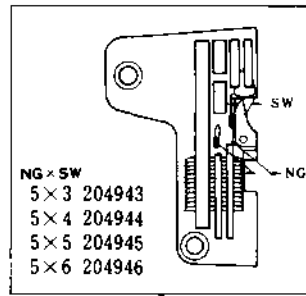
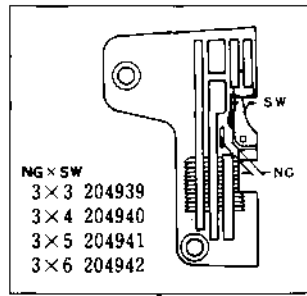

NG = Needle Gauge
 SW = Seam Width

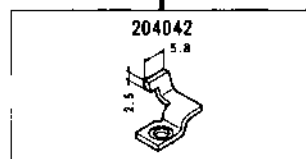
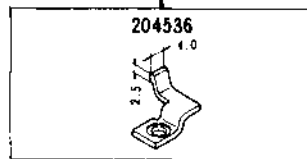
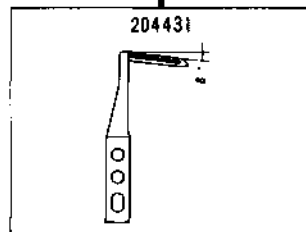
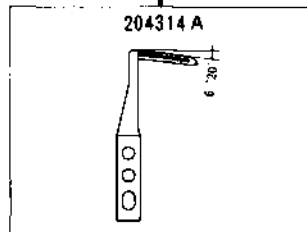
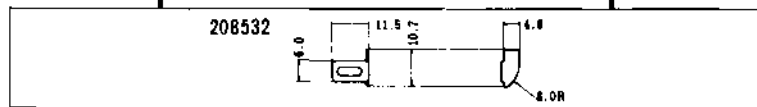
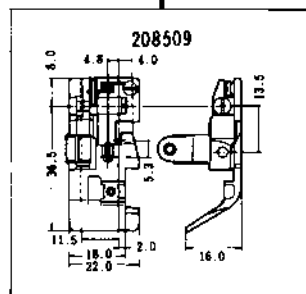
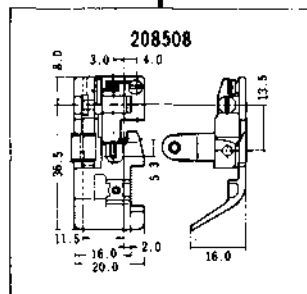
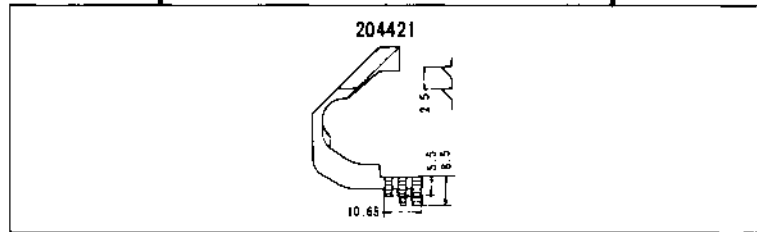
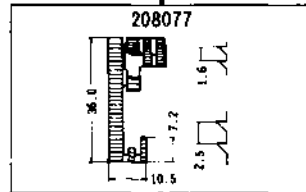
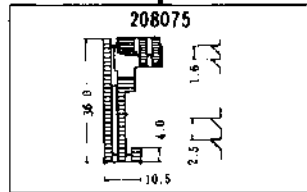

39 P1 (P2)
 NG (3mm)

39 P1 (P2)
 (5mm)

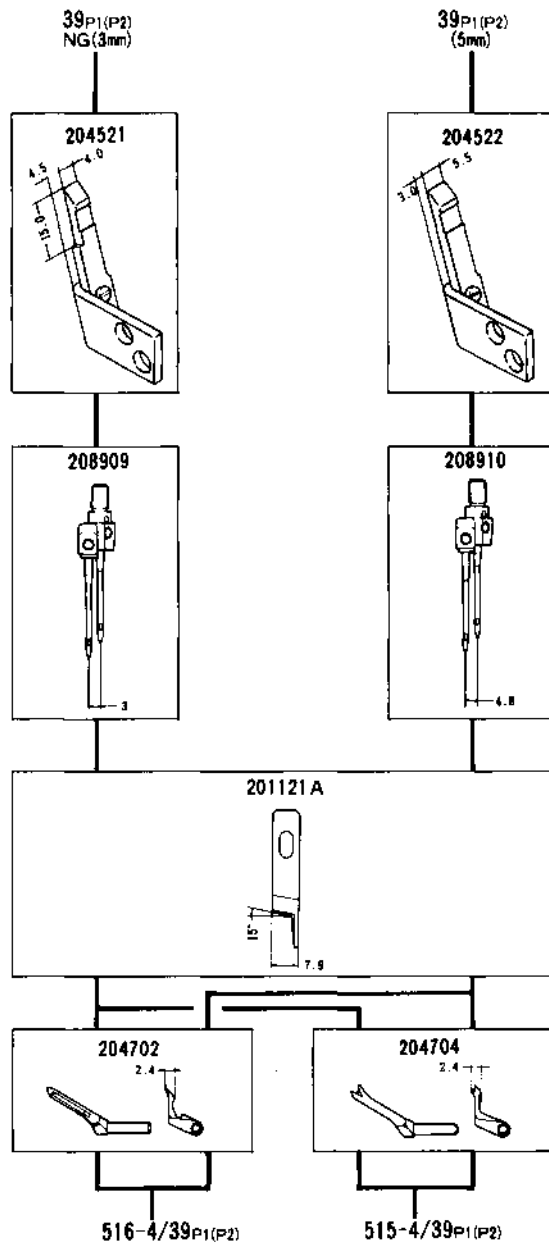

**GAUGE PARTS
CONSTRUCTION CHART**

355, 359, 555, 559

Feed pattern : 2N (2-row narrow)
2W (2-row wide)

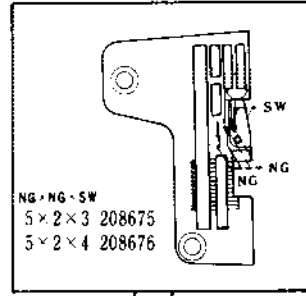
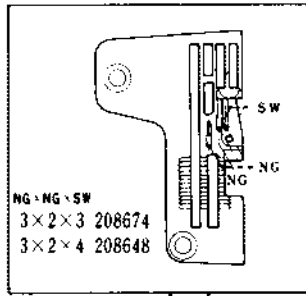

NG = Needle Gauge
SW = Seam Width

355 359

555 559

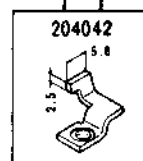
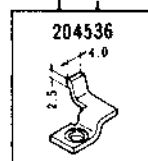
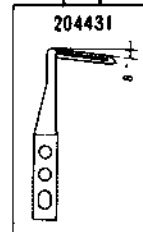
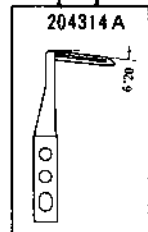
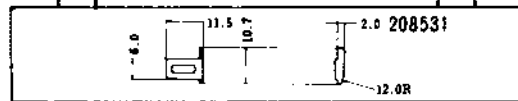
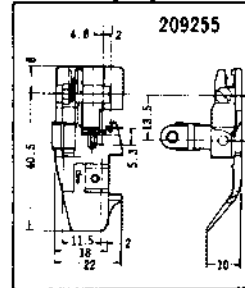
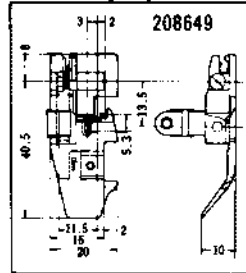
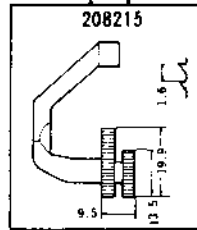
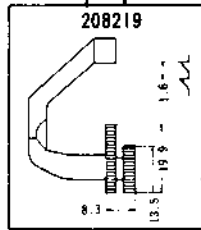
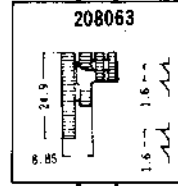
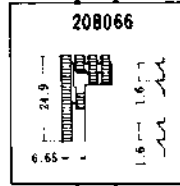





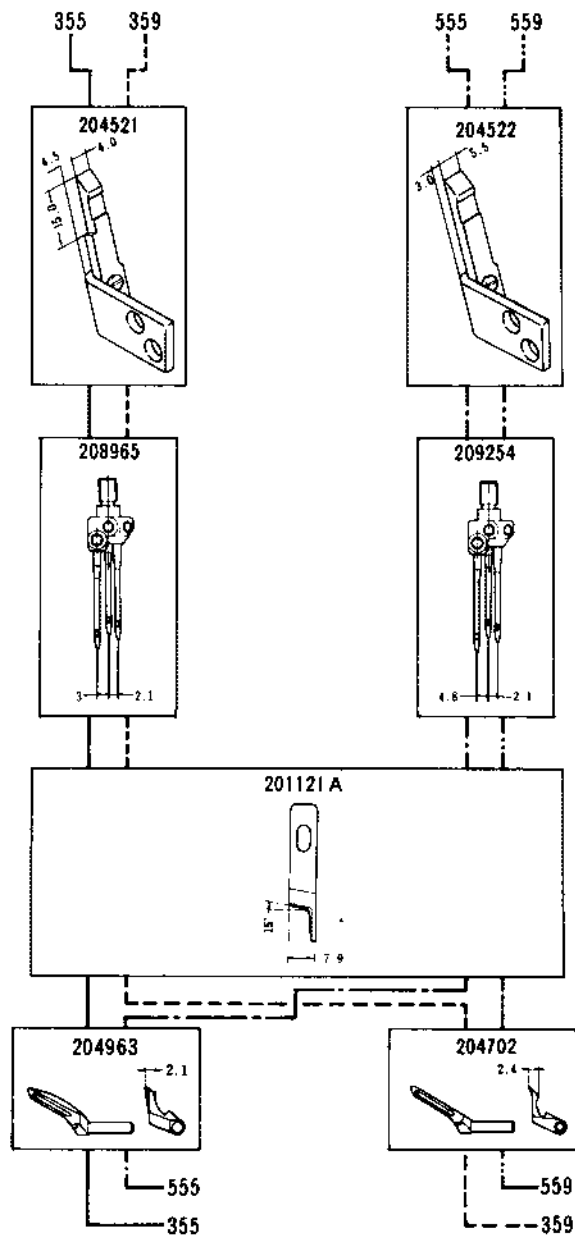

355 359

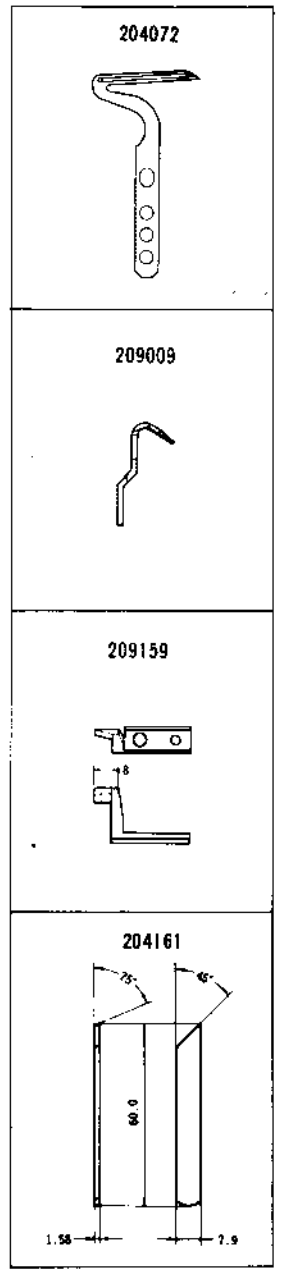
555 559



COMMON GAUGE PARTS



				MEMO	
355	3×2	3,4	0.6~2		Versatile high speed machines. Five different stitch types make them especially suitable for short run, high fashion locations. Two further stitch types (503, 515) can be obtained merely by changing the upper looper.
359	3×2	3,4	0.6~2		
555	5×2	3,4	0.6~2		
559	5×2	3,4	0.6~2		

**GAUGE PARTS
CONSTRUCTION CHART**

Feed pattern : 2-row
Chaining land : no

505-4/25
504-4/19

204072
204991
(514-4/18s1, 18s2, 18s4, 18s5)i

201121A
(Except
514-4/18s4)

COMMON GAUGE PARTS
FOR ALL MACHINE TYPES
UP TO PAGE 123

SW
2 202616
3 202617
4 202618
5 204913

① 19
② 25

204729A

204674

NG = Needle Gauge
SW = Seam Width

204730

= Standard parts

= Optional parts

201152E

201473B





201155C

201224B

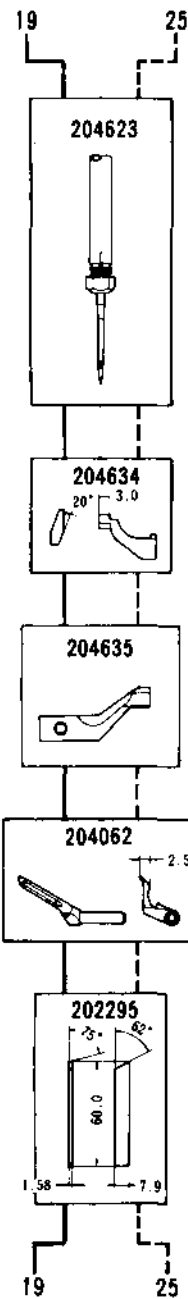
210584

25 19



				MEMO	
505-4/25	2, 3, 4, 5	505	0.6~2		Three thread blindstitch hemming on U-necked undershirts athletic shirts, mens and womens briefs etc.
504-4/19	2, 3, 4, 5	504	0.6~2		For sleeve, side and shoulder closing operations on light to medium weight materials such as underwear and ladies' and children's outerwear.



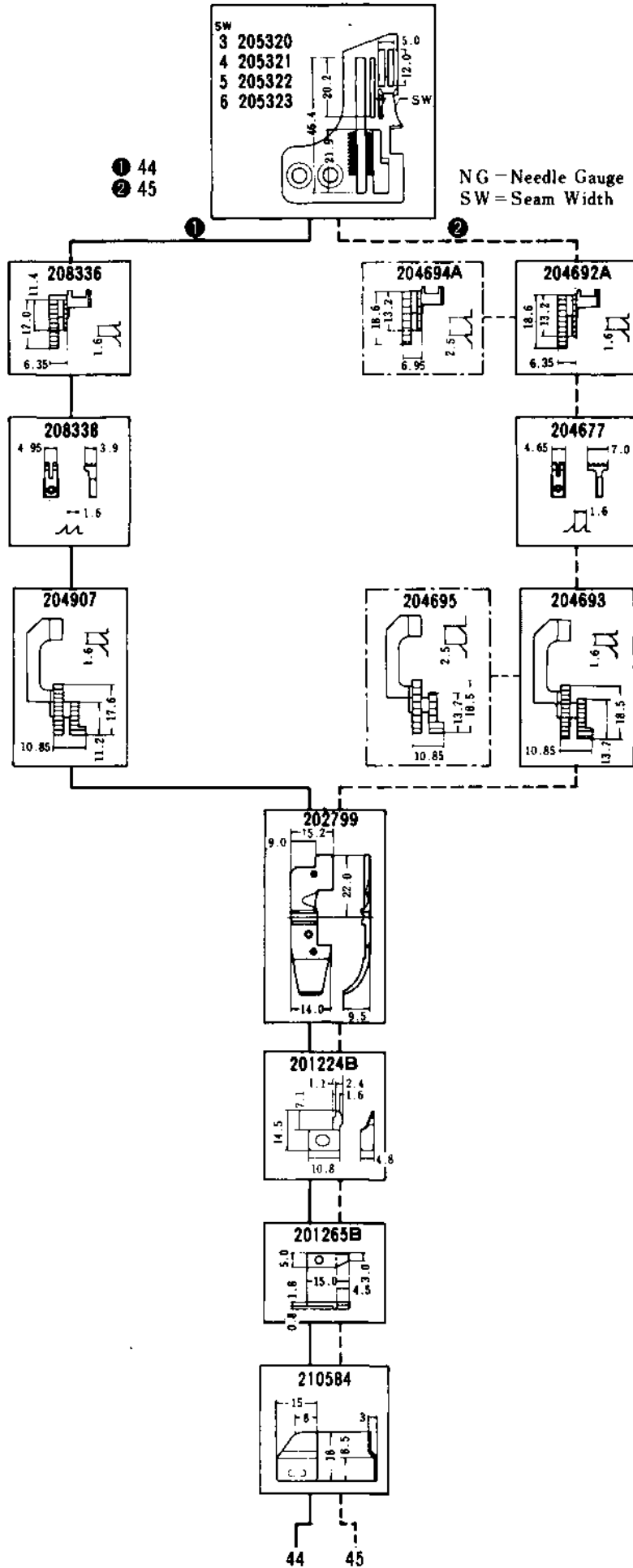

**GAUGE PARTS
CONSTRUCTION CHART**

Feed pattern : 2-row
Chaining land : yes

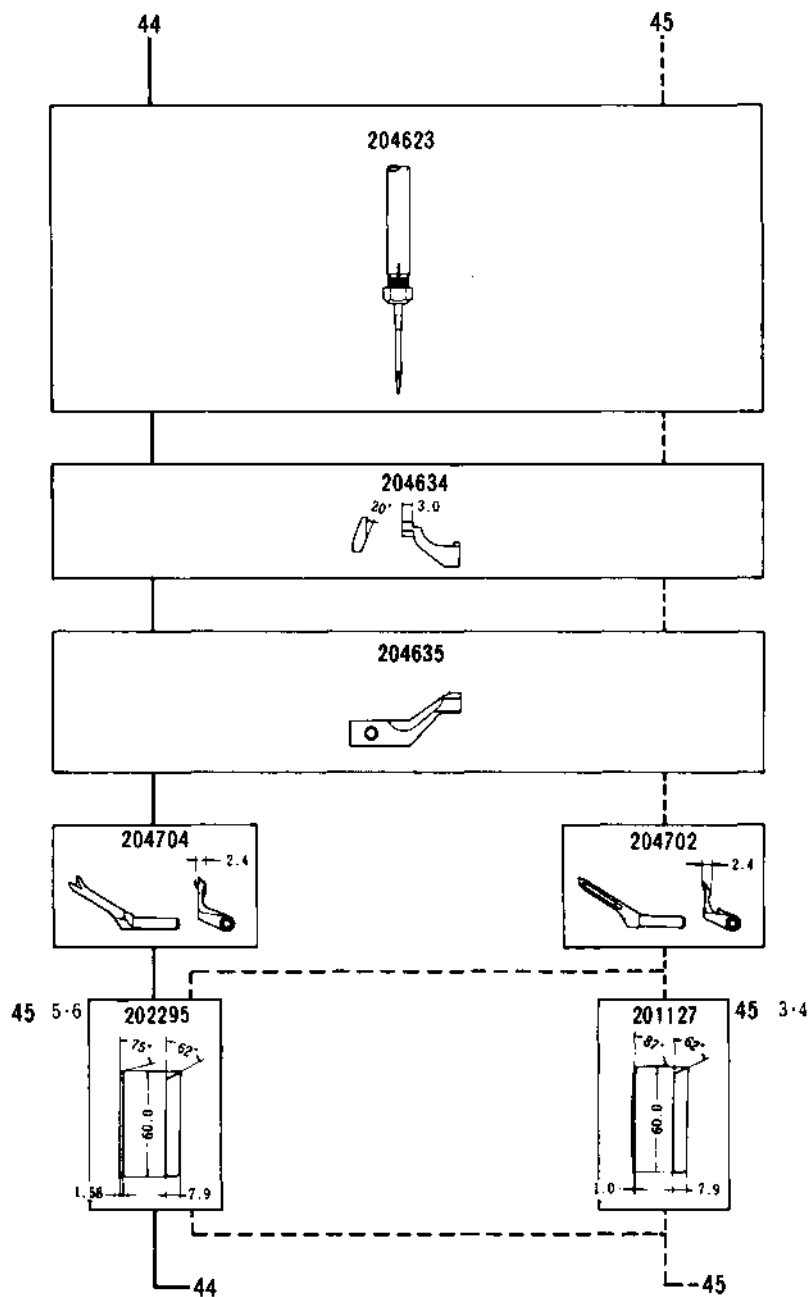
503-4/44
504-4/45





				MEMO	
503-4/44	3, 4, 5, 6	503	0.6~1.3		General serging operations on slacks, jackets working wear etc.
504-4/45	3, 4, 5, 6	504	0.6~2		For sleeve, side and shoulder closing operations on light to medium weight materials such as underwear and ladies' and children's outerwear.

**GAUGE PARTS
CONSTRUCTION CHART**

504-4/7, 66, 65, 69, 21

Feed pattern : 3-row
Chaining land : no

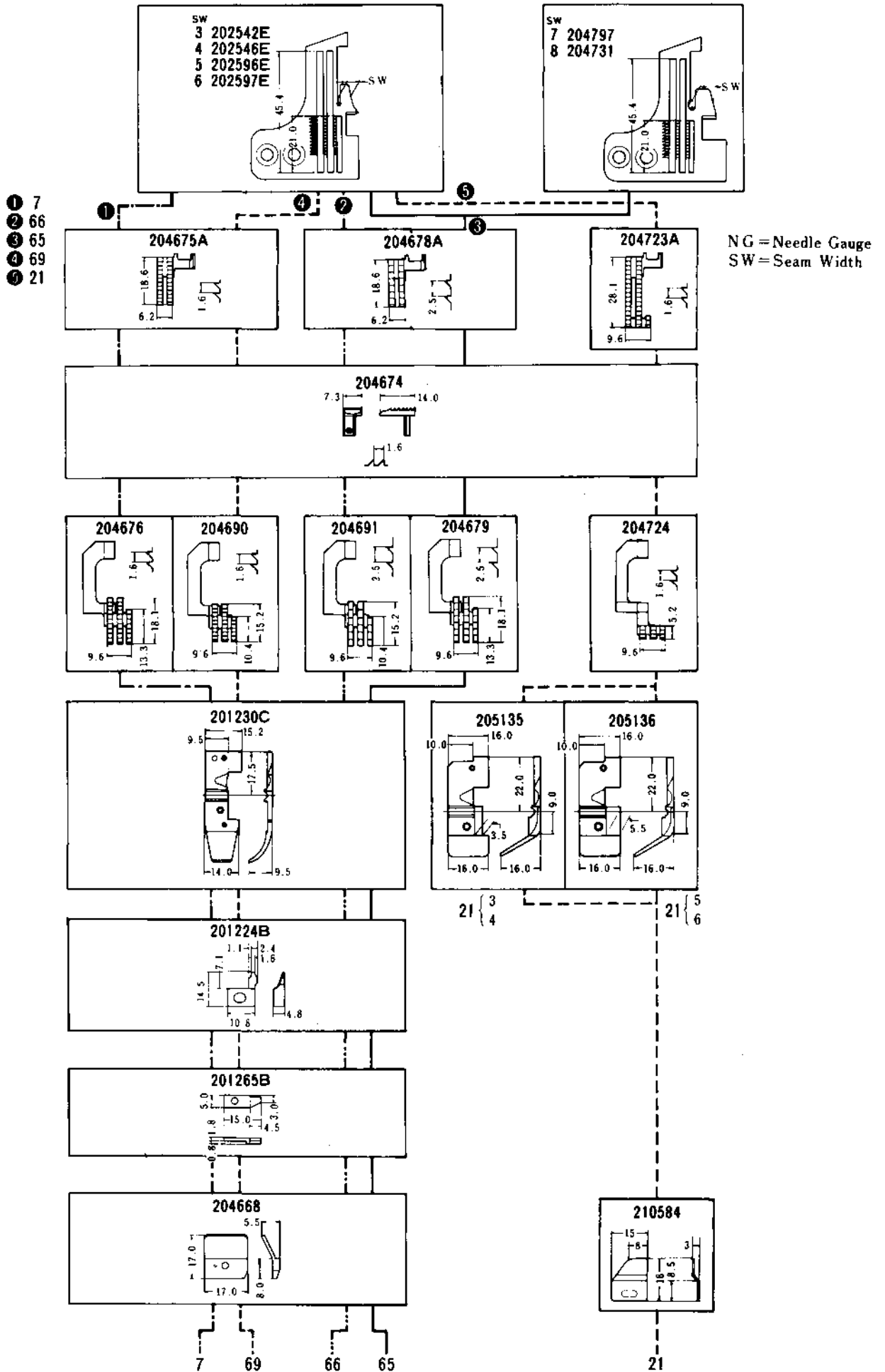

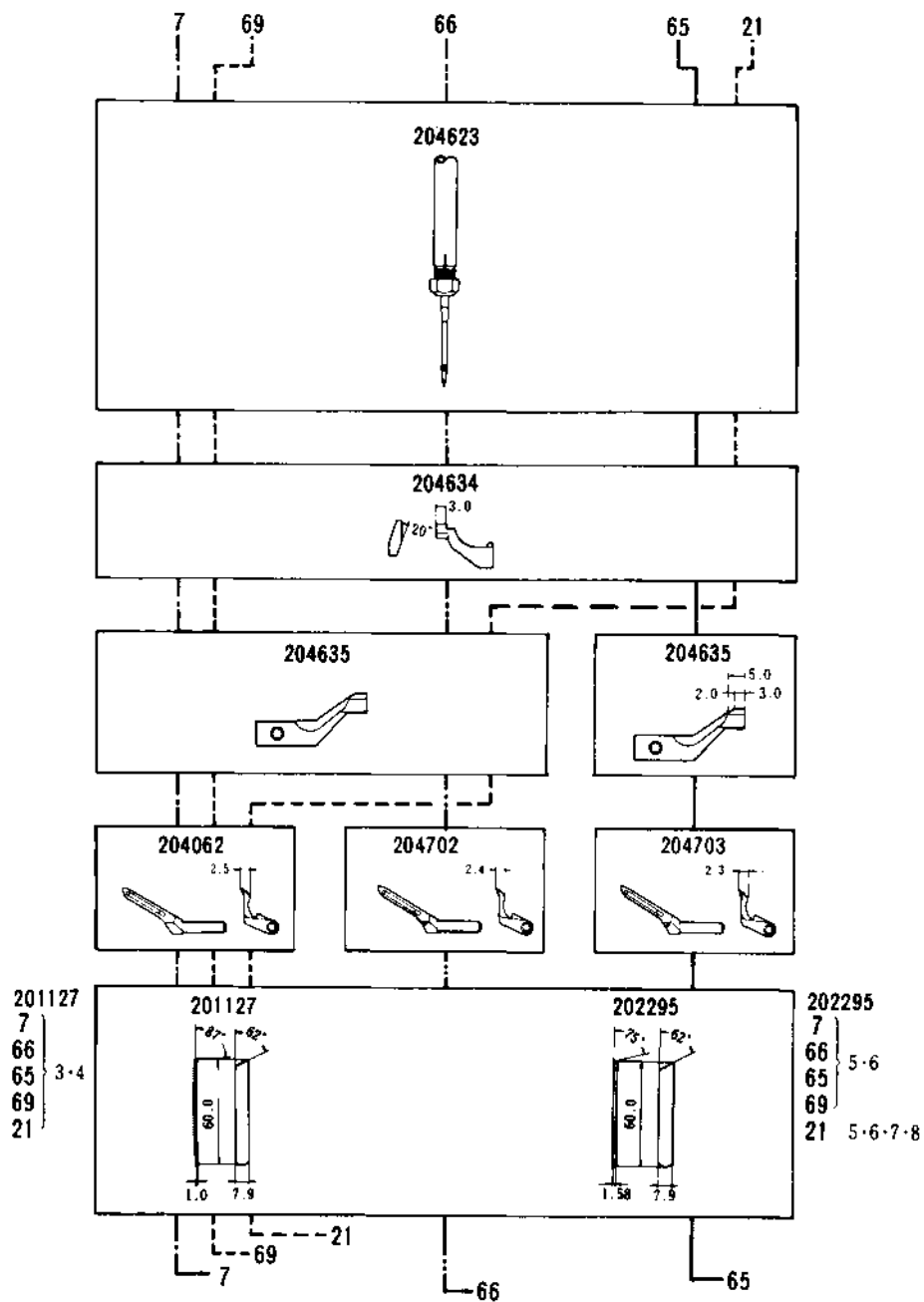

				MEMO	
504-4/7	3, 4, 5, 6	504	0.6~2		For sleeve, side and shoulder closing operations on light to medium weight materials such as underwear and ladies' and children's outerwear.
504-4/66	3, 4, 5, 6	504	1~3		Specially designed for seaming bulky knit materials such as sweaters, cardigans etc.
504-4/65	3, 4, 5, 6 7, 8	504	0.6~2		Seaming or serging on extra heavy weight materials such as jeans.
504-4/69	3, 4, 5, 6	504	1~3		For sleeve, side and shoulder closing operations on light to medium weight materials such as underwear and ladies' and children's outerwear.
504-4/21	3, 4, 5, 6	504	1~3		Single needle overedgers for intermittent shirring on light to medium weight materials such as negligee, curtains etc.

**GAUGE PARTS
CONSTRUCTION CHART**

Feed pattern : 3-row
Chaining land : yes

**503-4/48
504-4/43, 47**

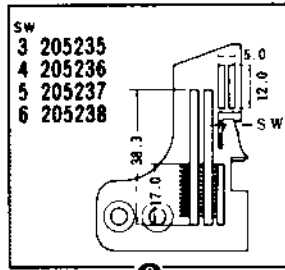
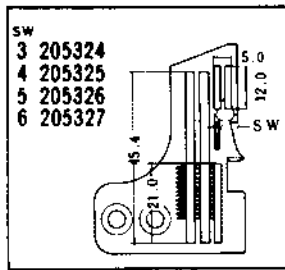

NG = Needle Gauge
SW = Seam Width

- ① 48
- ② 47
- ③ 43

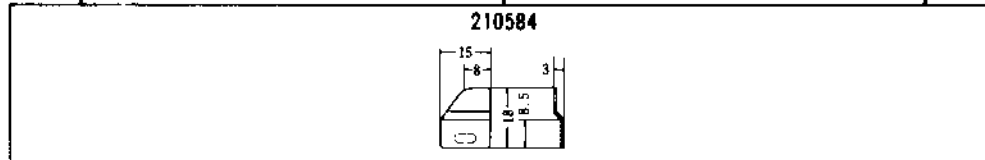
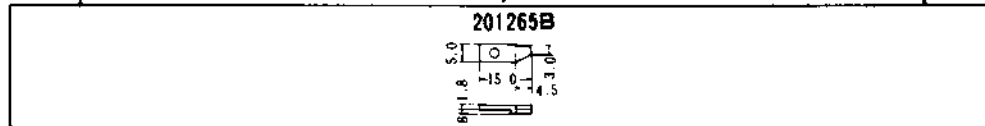
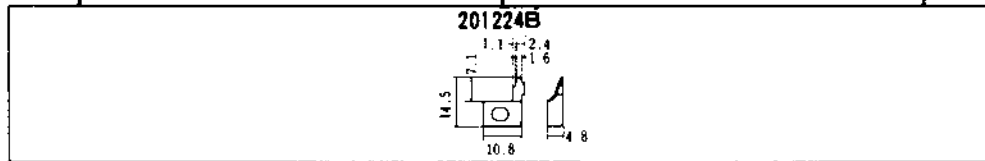
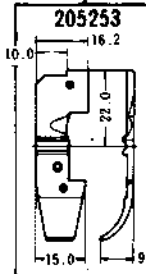
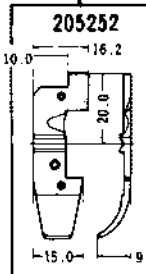
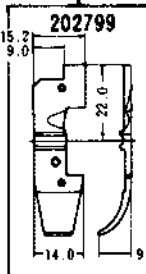
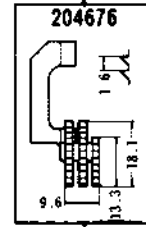
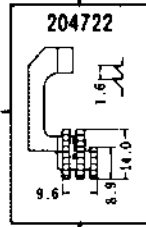
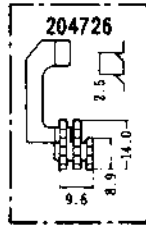
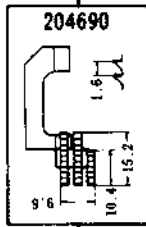
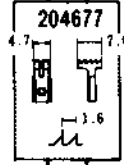
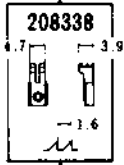
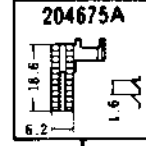
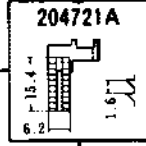
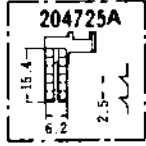
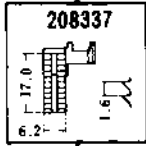



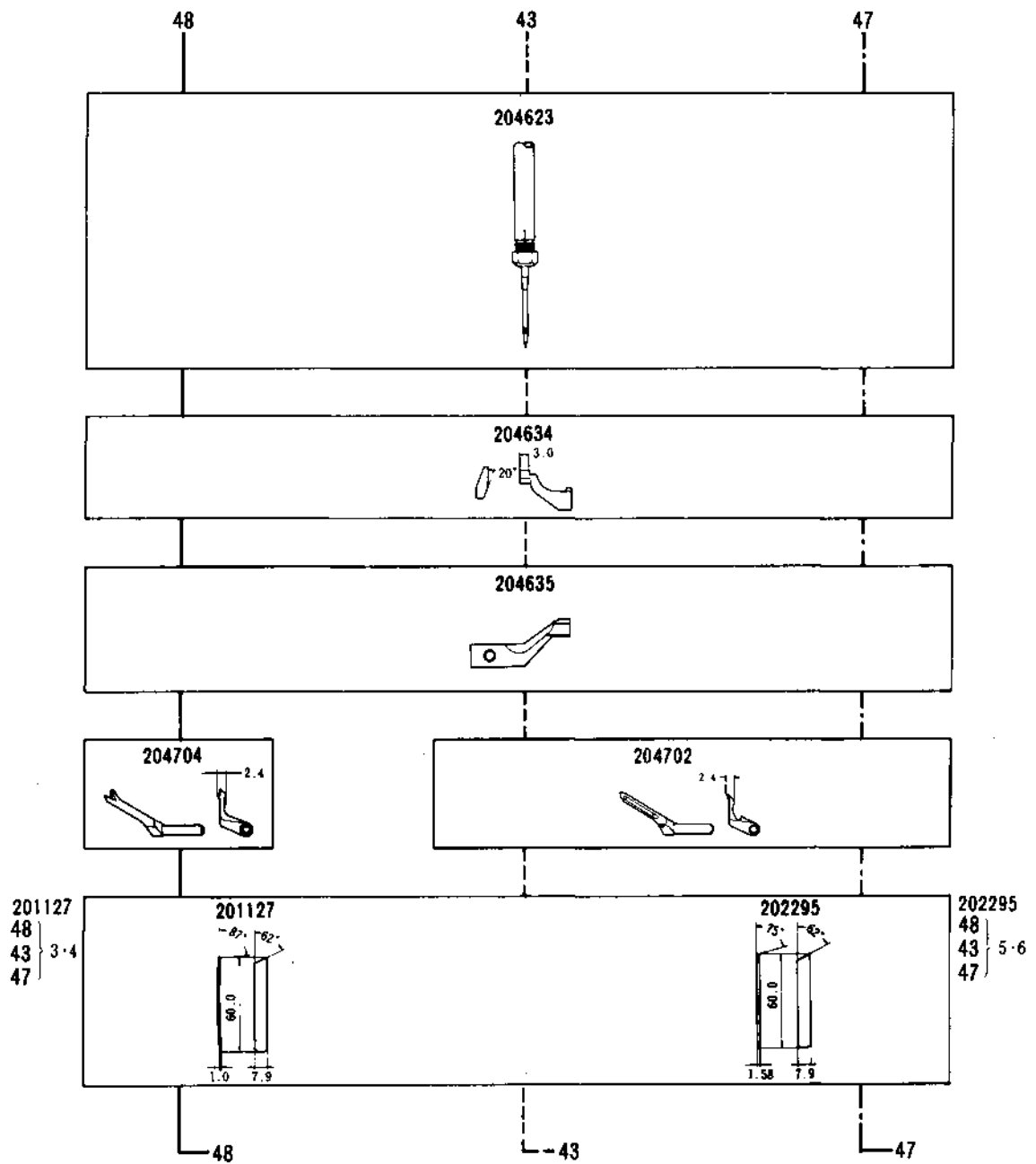

48

43

47



				MEMO	
503-4/48	3, 4, 5, 6	503	0.6~1.3		General serging operations on slacks, jackets working wear etc.
504-4/43	3, 4, 5, 6	504	0.6~2		For sleeve, side and shoulder closing operations on light to medium weight materials such as underwear and ladies' and children's outerwear.
504-4/47	3, 4, 5, 6	504	0.6~2		Seaming on medium heavy materials such as bed spreaders, chair covers etc.

**GAUGE PARTS
CONSTRUCTION CHART**

Feed pattern : 2-row, 1-row
Chaining land : no

504-4/16s2, 260

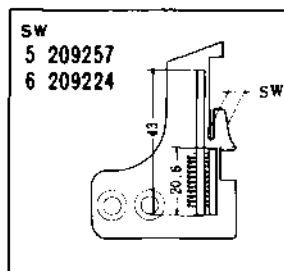
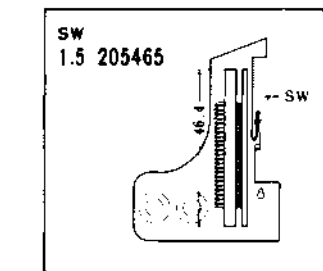

NG = Needle Gauge
SW = Seam Width



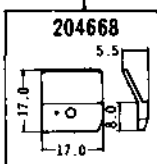
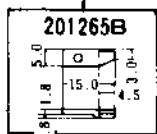
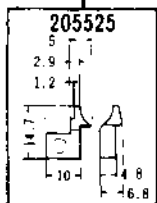
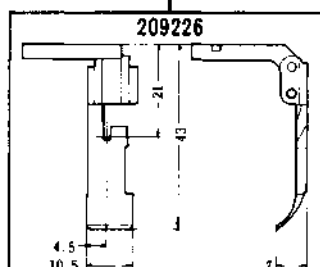
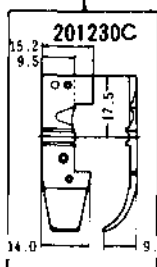
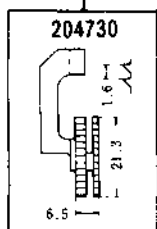
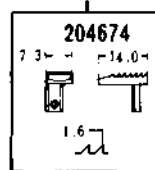
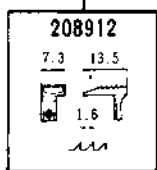
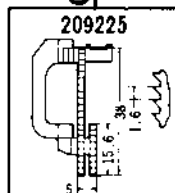
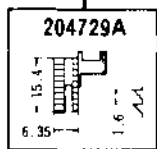

- ① 16s2
- ② 260

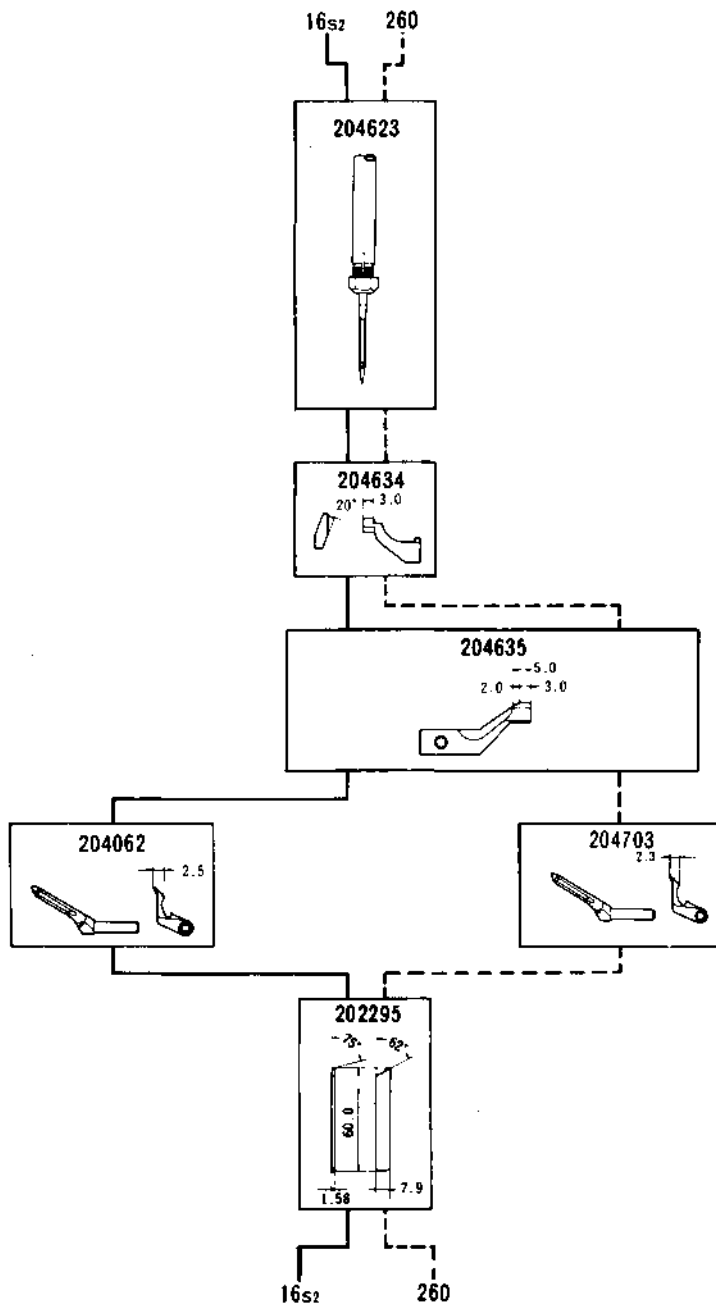

16s2

260



				MEMO	
504-4/16s2	1.5	504	0.6 ~ 2		Three thread overedger for turndown hemming on lightweight materials such as handkerchiefs, curtains etc.
504-4/260	5,6	504			Attaching zipper.

**GAUGE PARTS
CONSTRUCTION CHART**

514-4/20

Feed pattern : 2-row
Chaining land : no

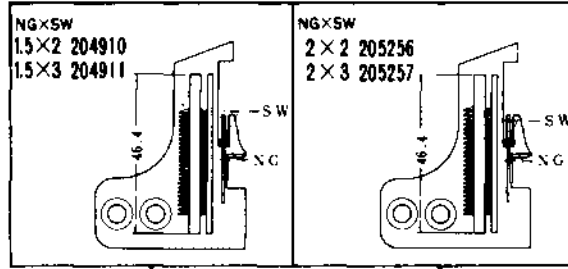

NG = Needle Gauge
SW = Seam Width

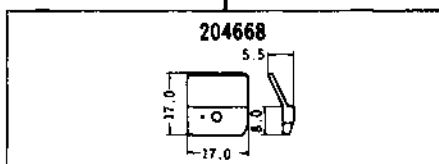
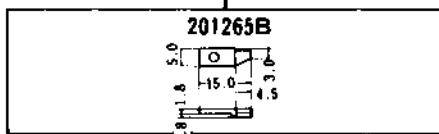
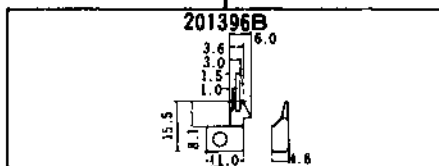
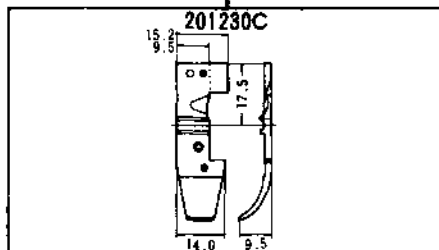
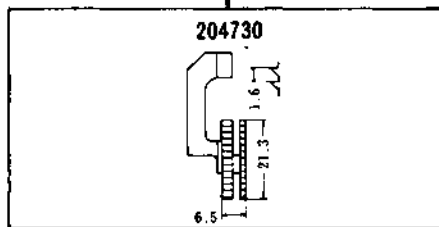
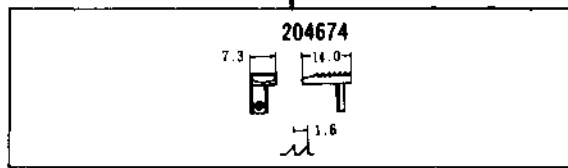
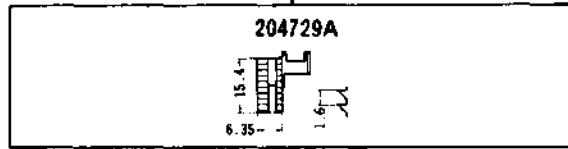

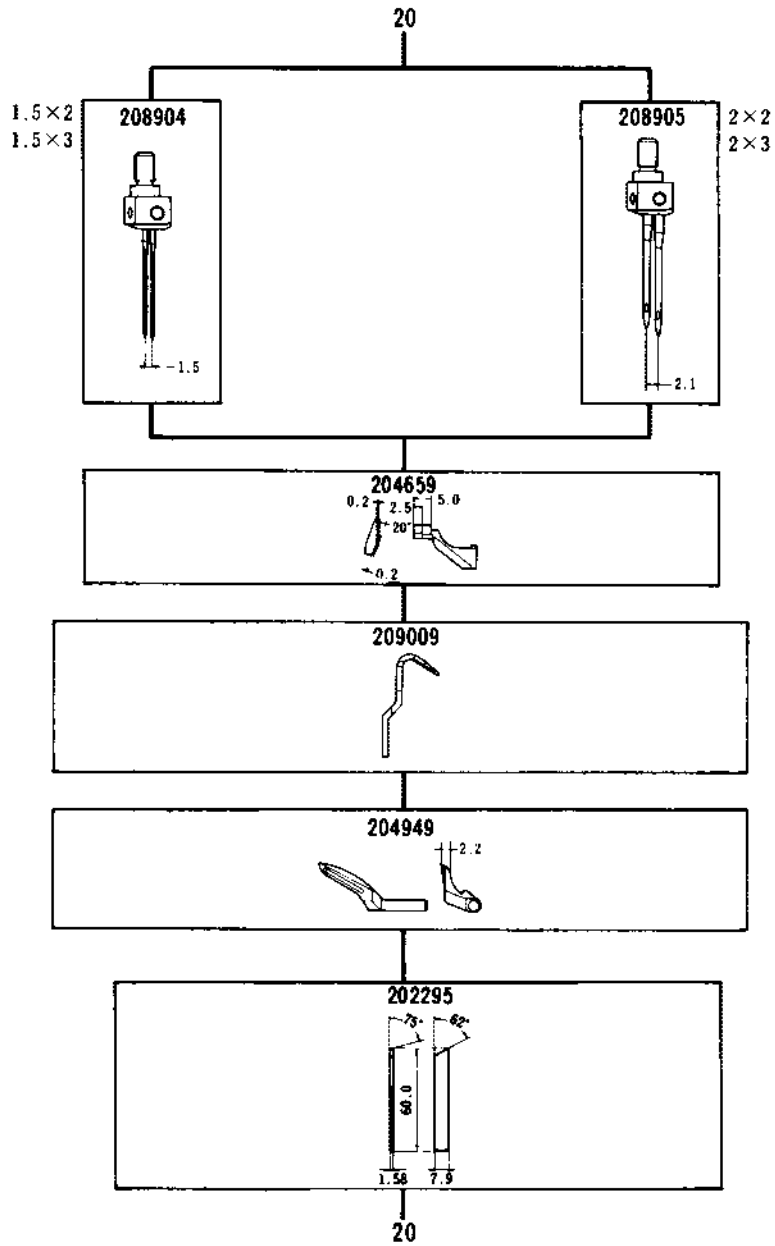

					MEMO	
514-4/20	1.5 2	2,3	514	0.6-2		Two needle machines for closing and attaching sleeves and side closing on light to medium weight materials.

**GAUGE PARTS
CONSTRUCTION CHART**

514-4/68, 61, 62, 67, 73

Feed pattern : 3-row
Chaining land : no

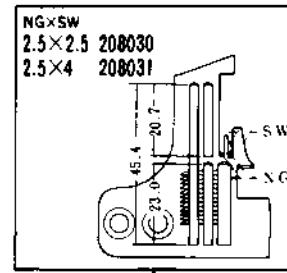
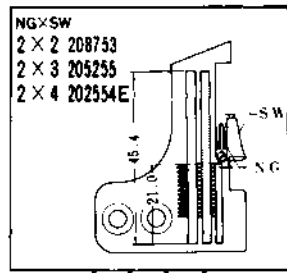

NG - Needle Gauge
SW = Seam Width

- ① 68
- ② 61
- ③ 67
- ④ 73
- ⑤ 62

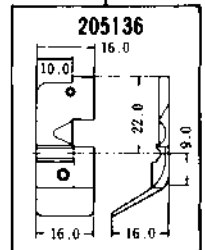
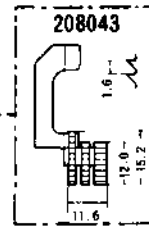
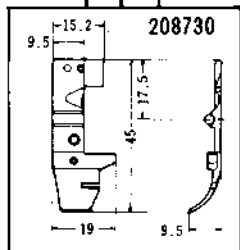
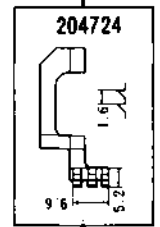
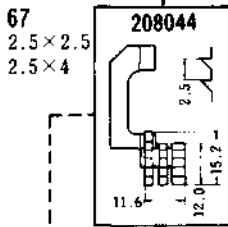
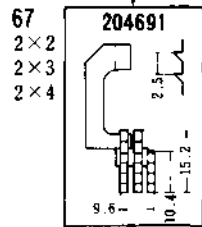
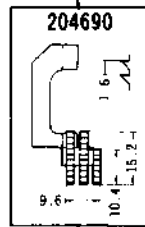
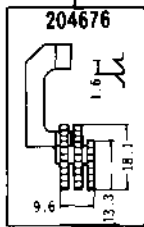
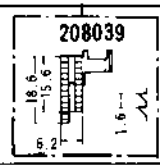
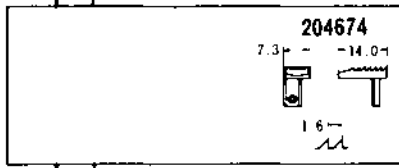
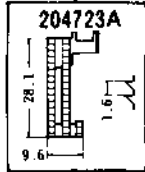
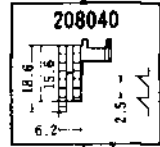
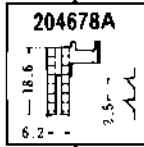
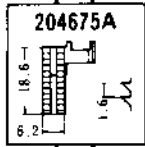

- 68 } 2×2
- 61 } 2×3
- 67 }

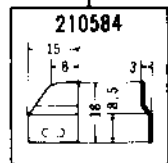
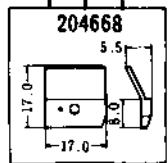
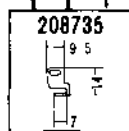
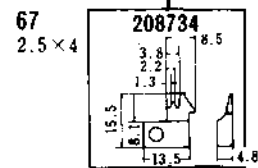
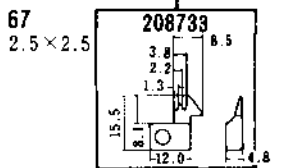
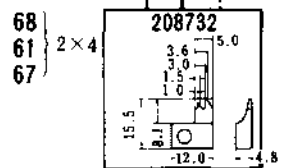
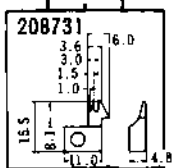





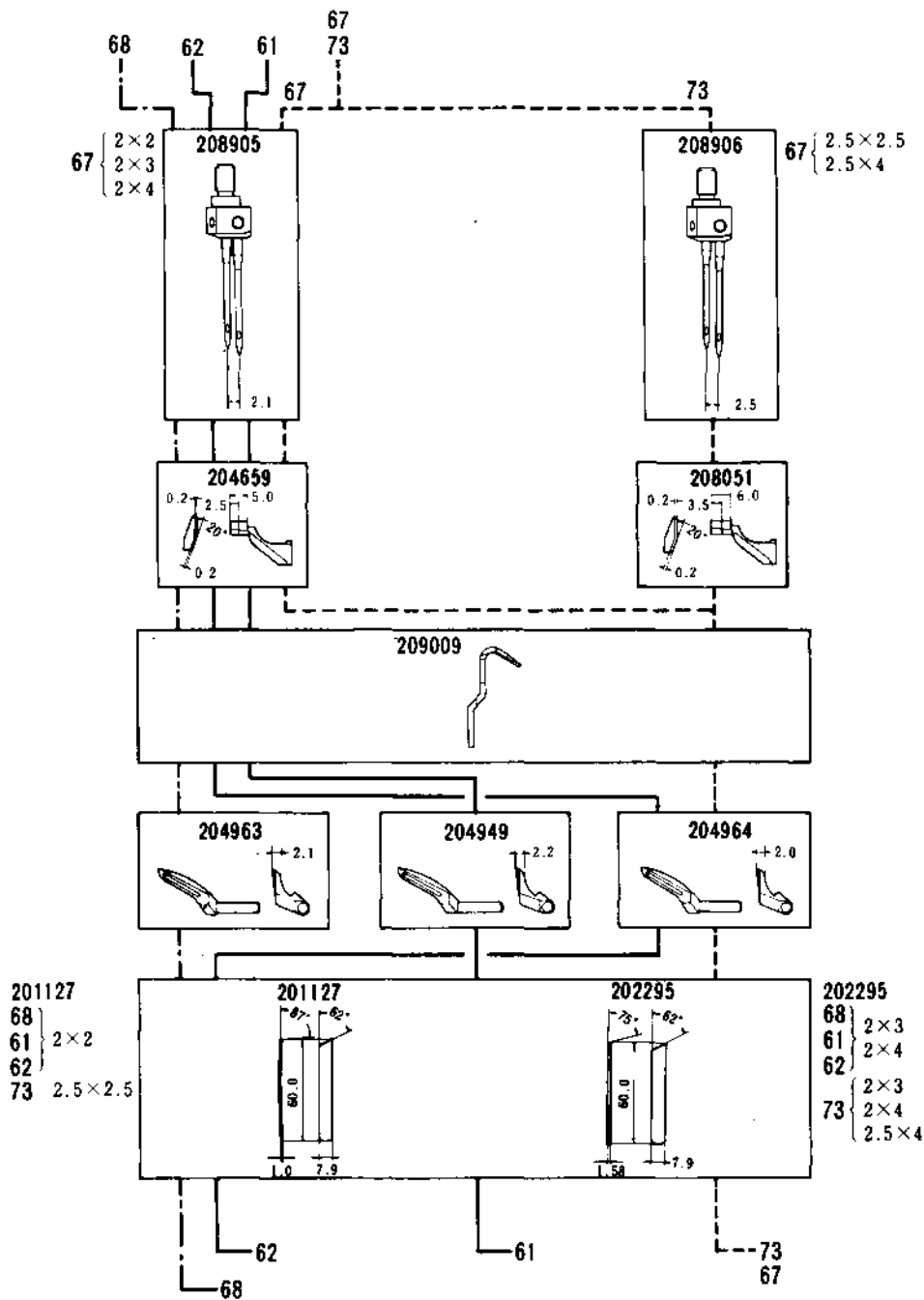

- 61
- 68
- 67
- 73

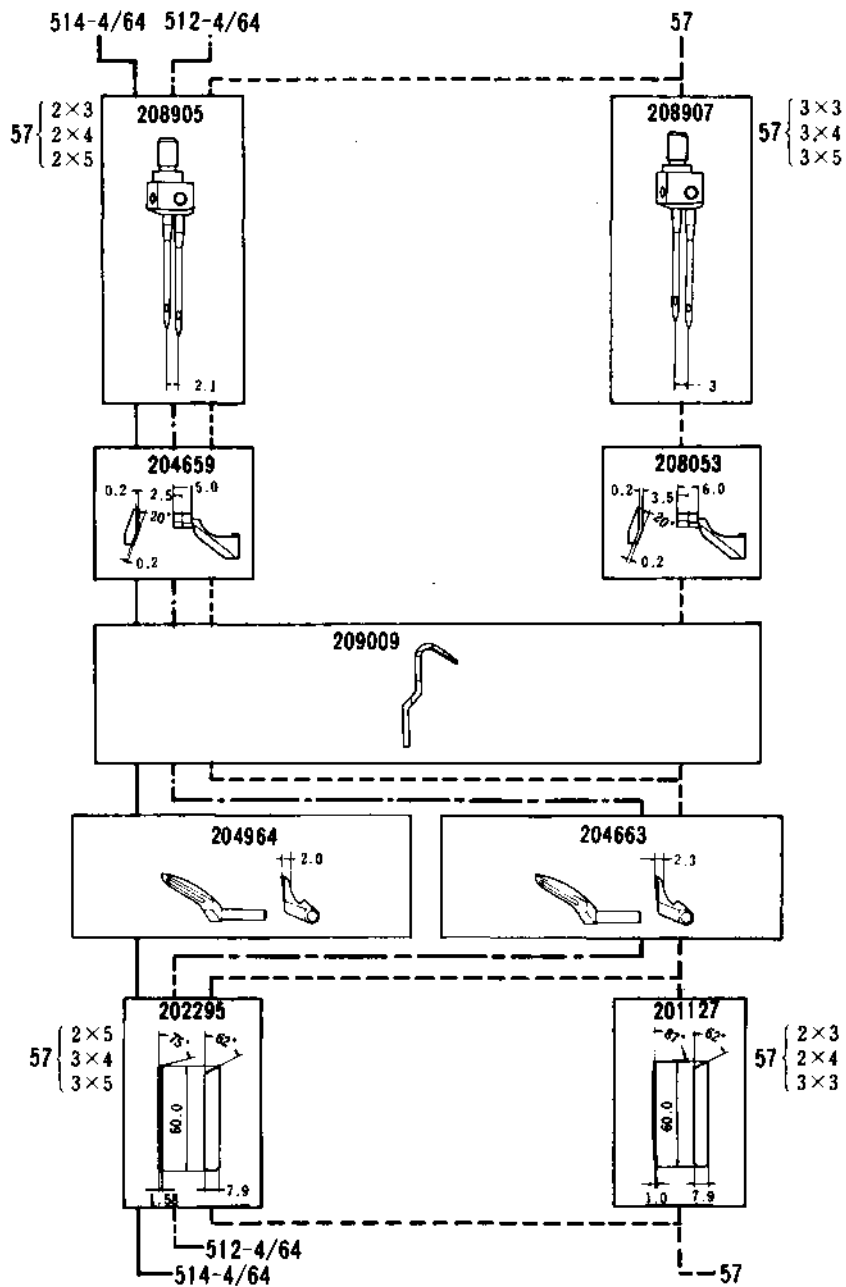
62



					MEMO	
514-4/68	2	2, 3, 4	514	1~3		Specially designed for seaming bulky knit materials such as sweaters, cardigans etc.
514-4/61	2	2, 3, 4	514	0.6~2		Two needle machines for closing and attaching sleeves and side closing on light to medium weight materials.
514-4/67	2	2, 3, 4	514	1~3		Specially designed for seaming bulky knit materials such as sweaters, cardigans etc.
514-4/73	2.5	2.5, 4				Two needle overedgers for intermittent shirring on light to medium weight materials such as negligee, curtains etc.
514-4/62	2	2, 3, 4	514	1~3		



					MEMO	
512-4/64	2	4,5	512	0.6~2		Closing and attaching sleeves and side closing on dress shirts.
514-4/64	2	4,5	514	0.6~2		Two needle machines for closing and attaching sleeves and side closing on light to medium weight materials.
512-4/57	2 3	3,4,5	512	0.6~2		Closing and attaching sleeves and side closing on dress shirts.

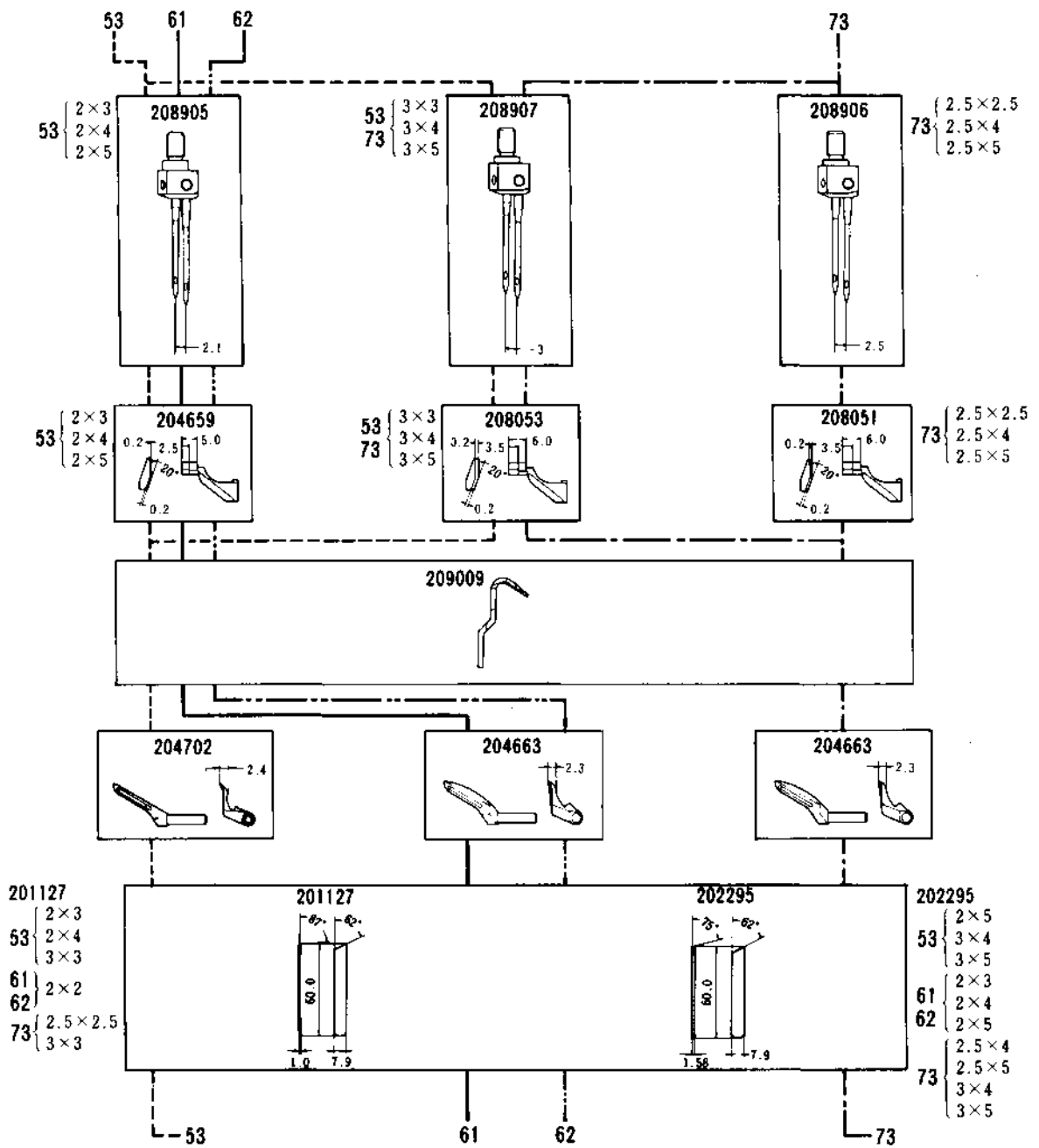

					MEMO	
512-4/53	2 3	3, 4, 5	512	0.6~2		Closing and attaching sleeves and side closing on dress shirts.
512-4/61	2	2, 3, 4, 5	512	0.6~2		
512-4/73	2.5 3	2.5, 4, 5 3, 4, 5	512	0.6~2		Specially designed for seaming bulky knit and woven materials such as sweaters, work wear etc.
512-4/62	2	2, 3, 4, 5	512	1~3		Mock safety stitch overedgers for intermittent shirring on light to medium weight materials such as negligee, curtain etc.





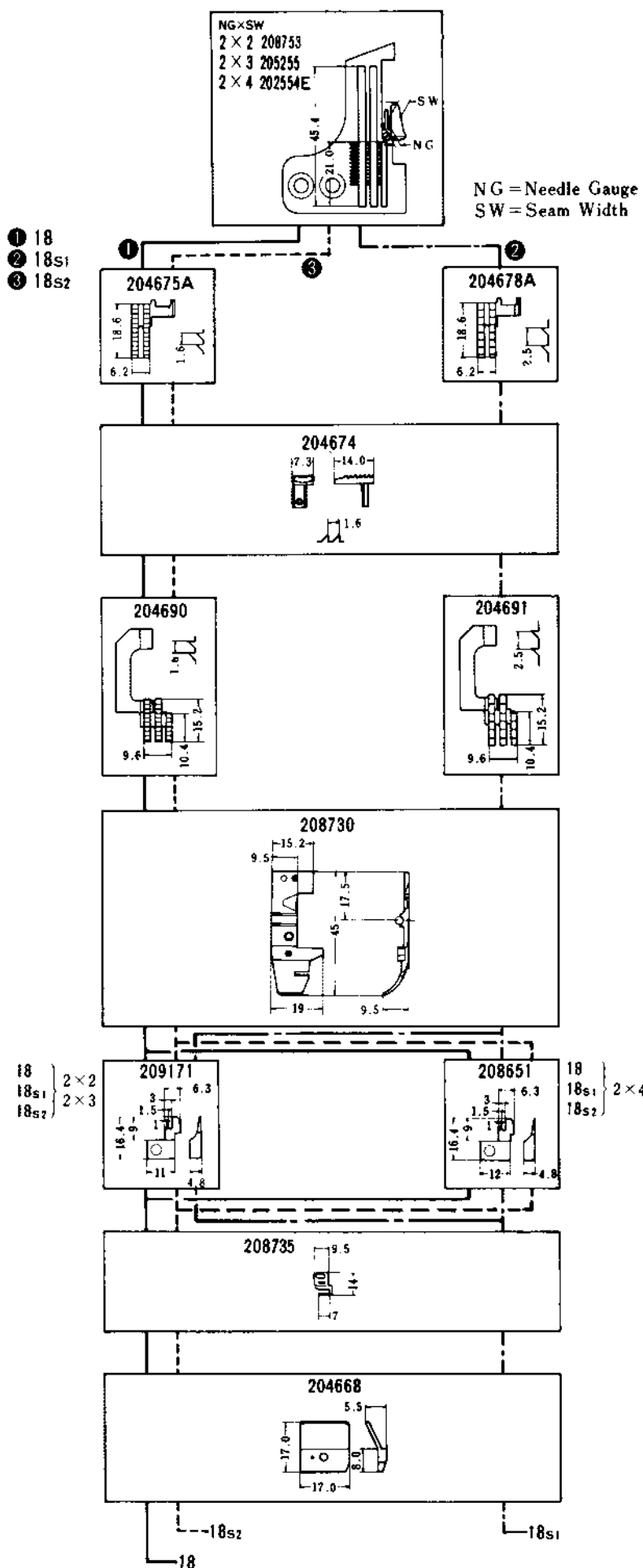

**GAUGE PARTS
CONSTRUCTION CHART**

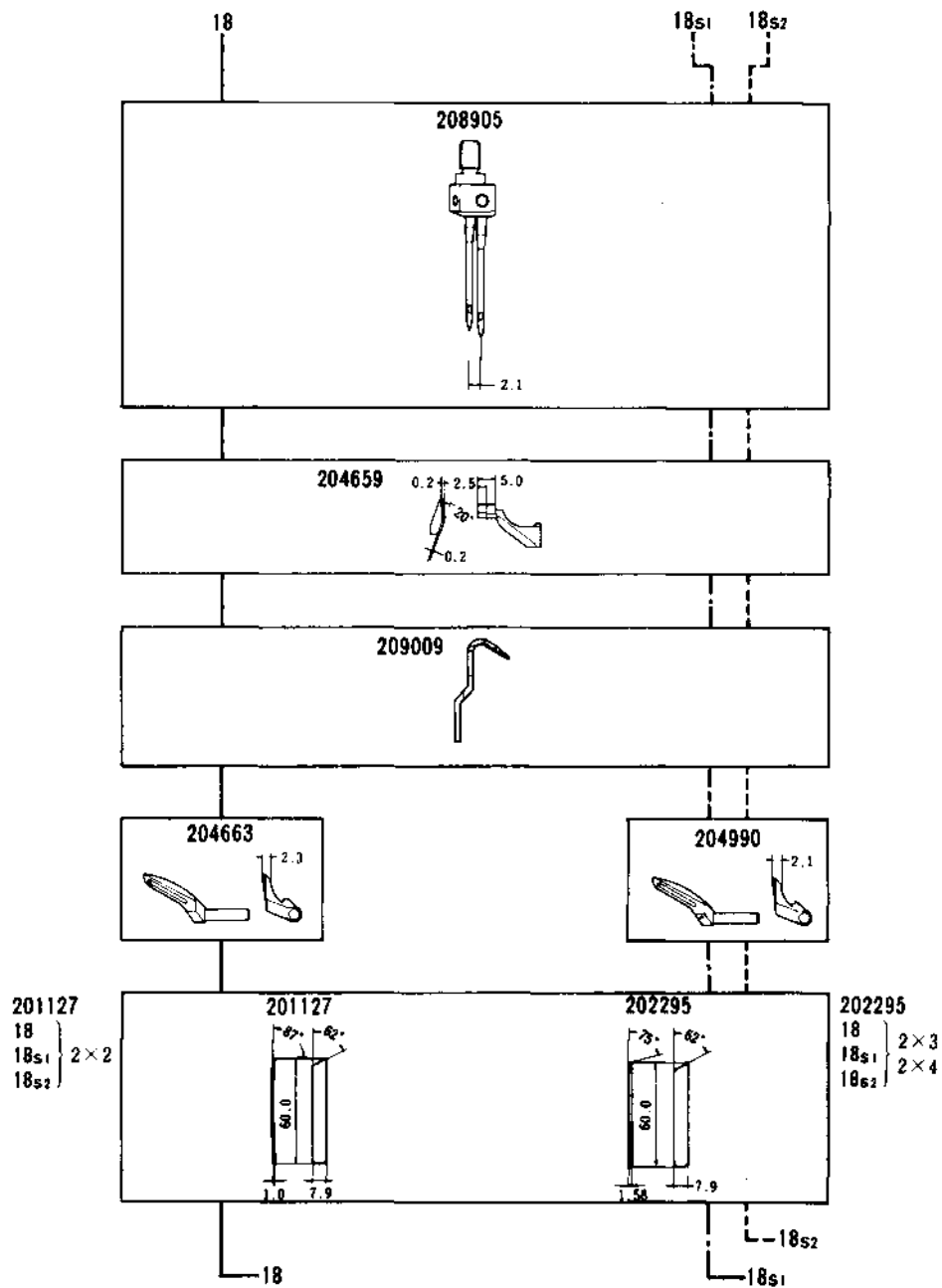
Feed pattern : 3-row
Chaining land : no

514-4/18, 18s1, 18s2





					MEMO	
514-4/18	2	2,3,4	514	1~3		Two needle machines for closing and attaching sleeves and side closing on light to medium weight materials.
514-4/18s1	2	2,3,4	514	1~3		Specially designed for seaming bulky knit materials such as sweaters, cardigans etc.
514-4/18s2	2	2,3,4	514	1~3		

**GAUGE PARTS
CONSTRUCTION CHART**

514-4/18s4, 18s5

Feed pattern : 4-row

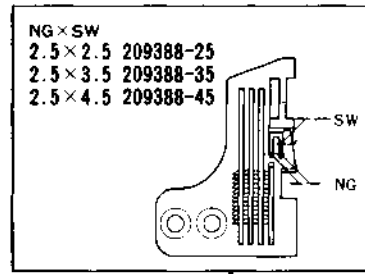
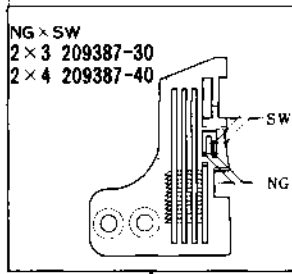



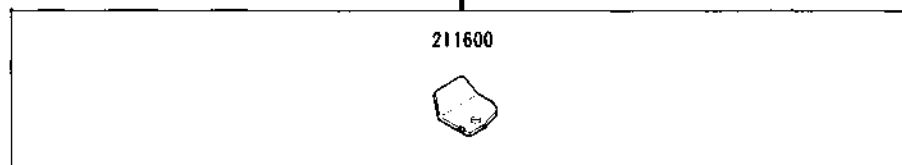
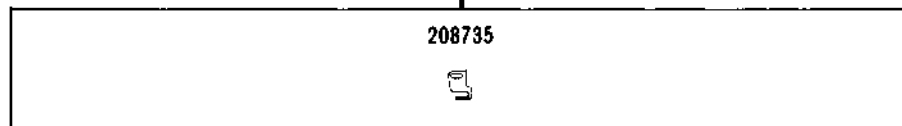
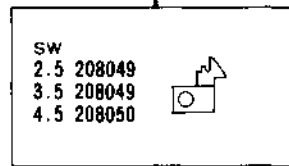
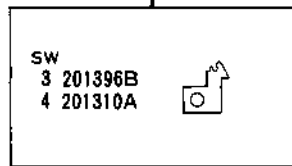
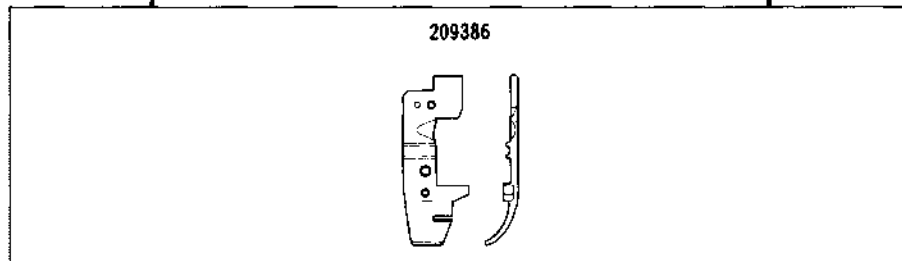
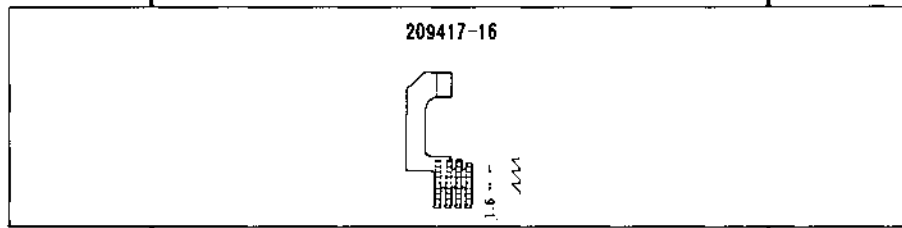
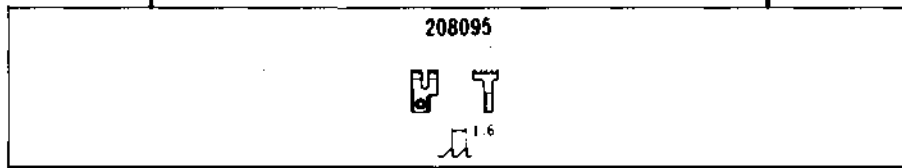
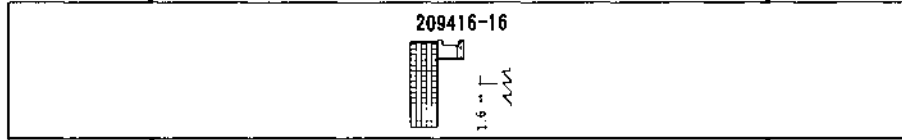

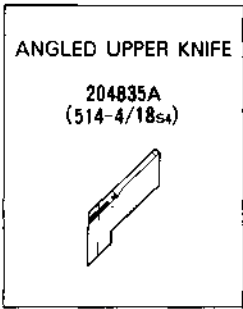
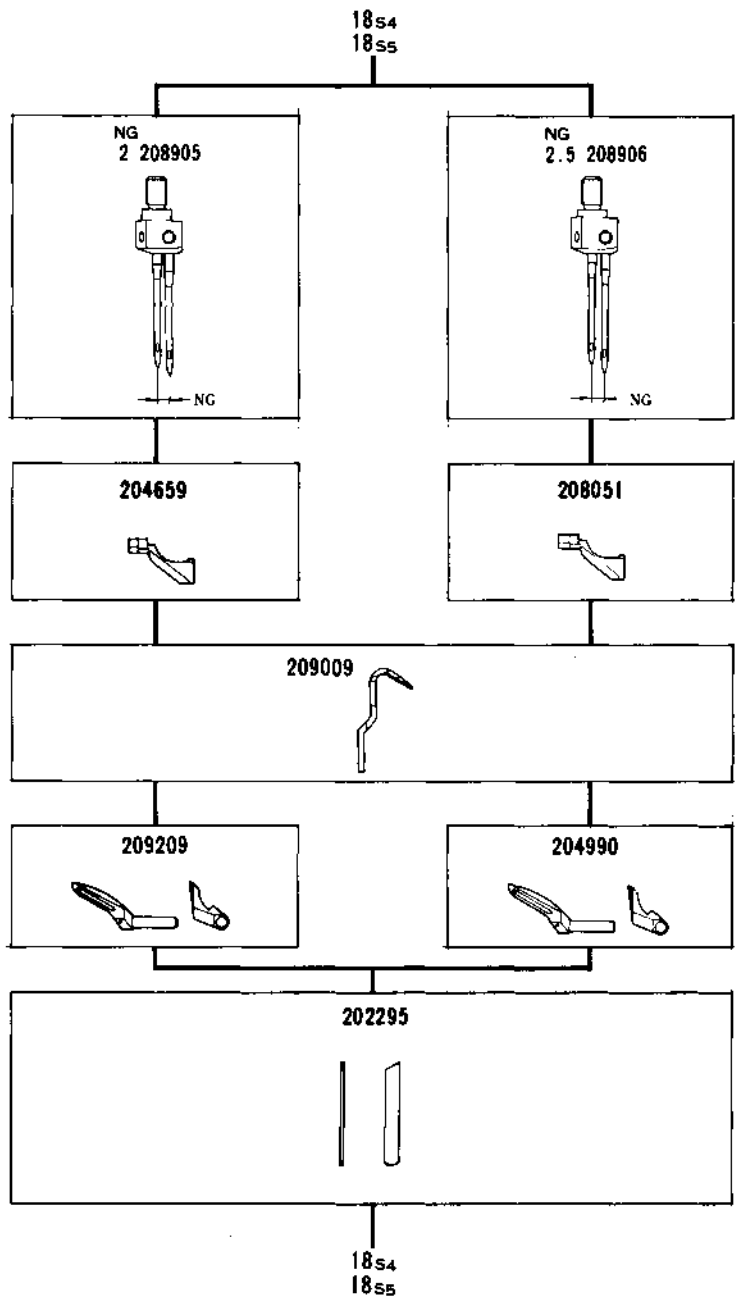

NG = Needle Gauge
SW = Seam Width



18s4
18s5



	 mm				MEMO	
514-4/18S4	2	3,4	514	1 ~ 3		For plain seaming on heavy weight fabrics (woolen fabrics) such as sweaters and cardigans.
	2.5	2.5,3.5,4.5				
514-4/18S5	2	3,4	514	1 ~ 3		For plain seaming on heavy weight fabrics (woolen fabrics) such as sweaters and cardigans.
	2.5	2.5,3.5,4.5				

**GAUGE PARTS
CONSTRUCTION CHART**

512-4/72

Feed pattern : 2-row
Chaining land : yes

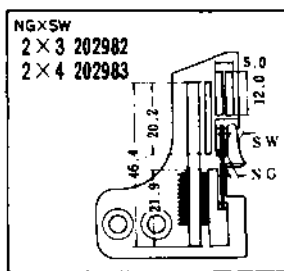

NG - Needle Gauge
SW - Seam Width

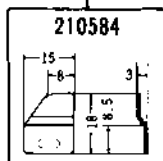
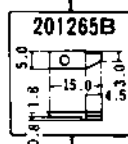
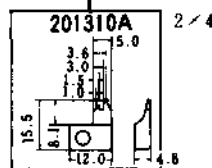
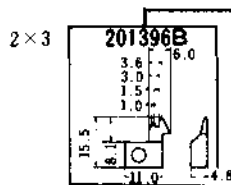
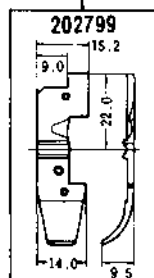
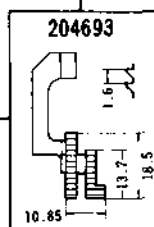
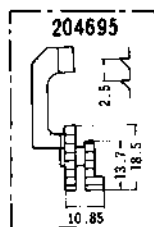
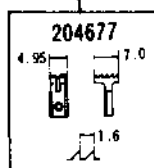
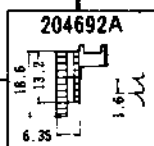
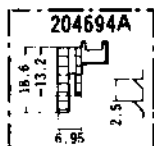

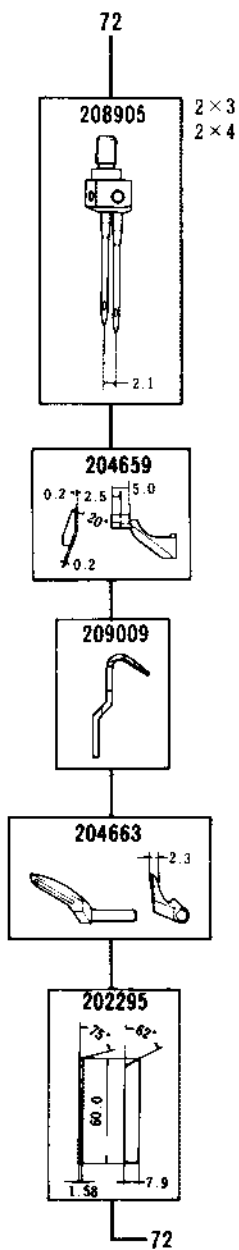

					MEMO	
512-4/72	2	3,4	512	0.6~2		Two needle machines for closing and attaching sleeves and side closing on light to medium weight materials.

**GAUGE PARTS
CONSTRUCTION CHART**

504-4/21 P1 (P2), 62 P1 (P2)

Feed pattern : 3-row

- ① 21 P1 (P2)
- ② 62 P1 (P2)

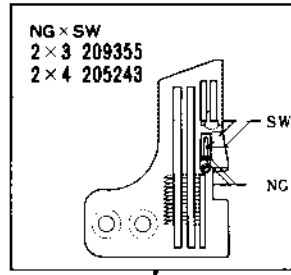
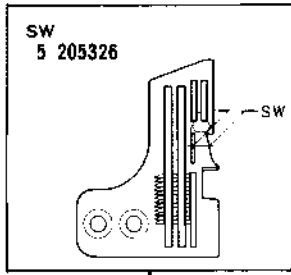



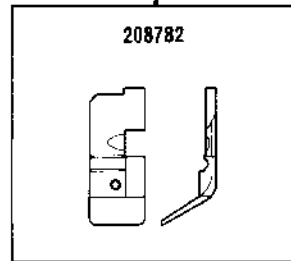
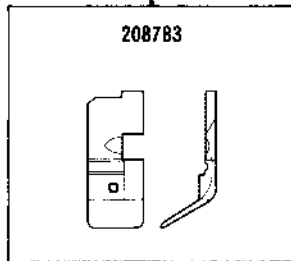
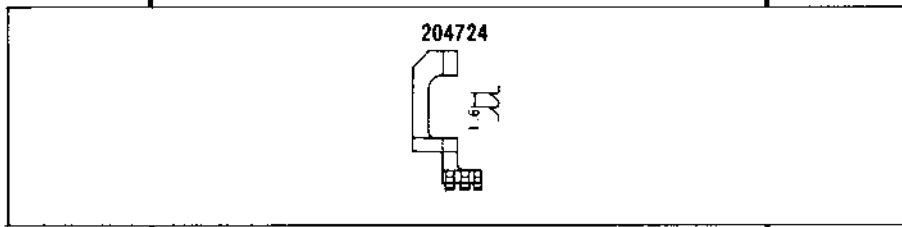
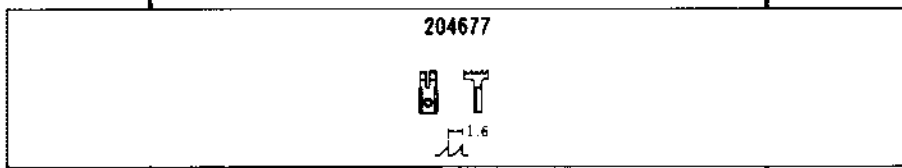
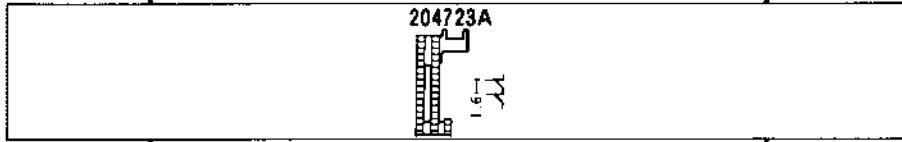



NG = Needle Gauge
SW = Seam Width

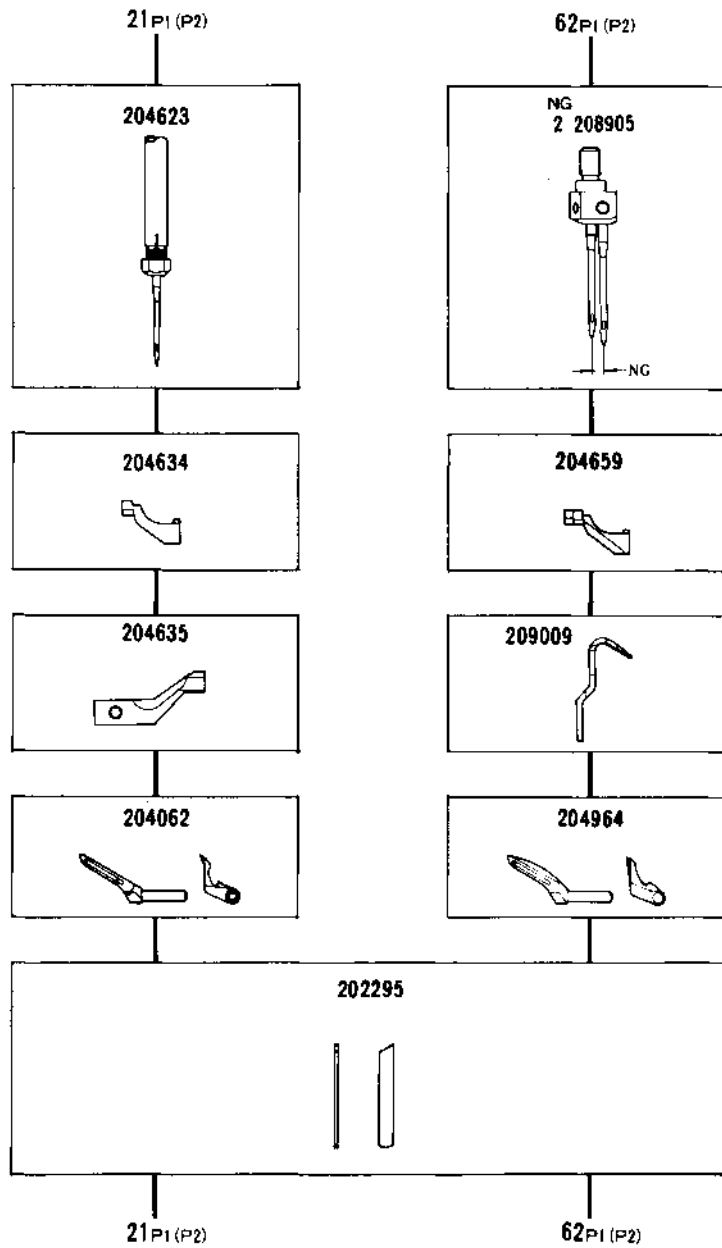

21 P1 (P2)

62 P1 (P2)



					MEMO	
504-4/21P1		5	504	1 ~ 3		For shirring/piping on medium weight fabrics such as knit shirts, sweat pants, pajamas and women's and kids' clothes.
504-4/21P2						
514-4/62P1	2	3,4	514	1 ~ 3		For shirring/piping on medium weight fabrics such as knit shirts, sweat pants, pajamas and women's and kids' clothes.
514-4/62P2						





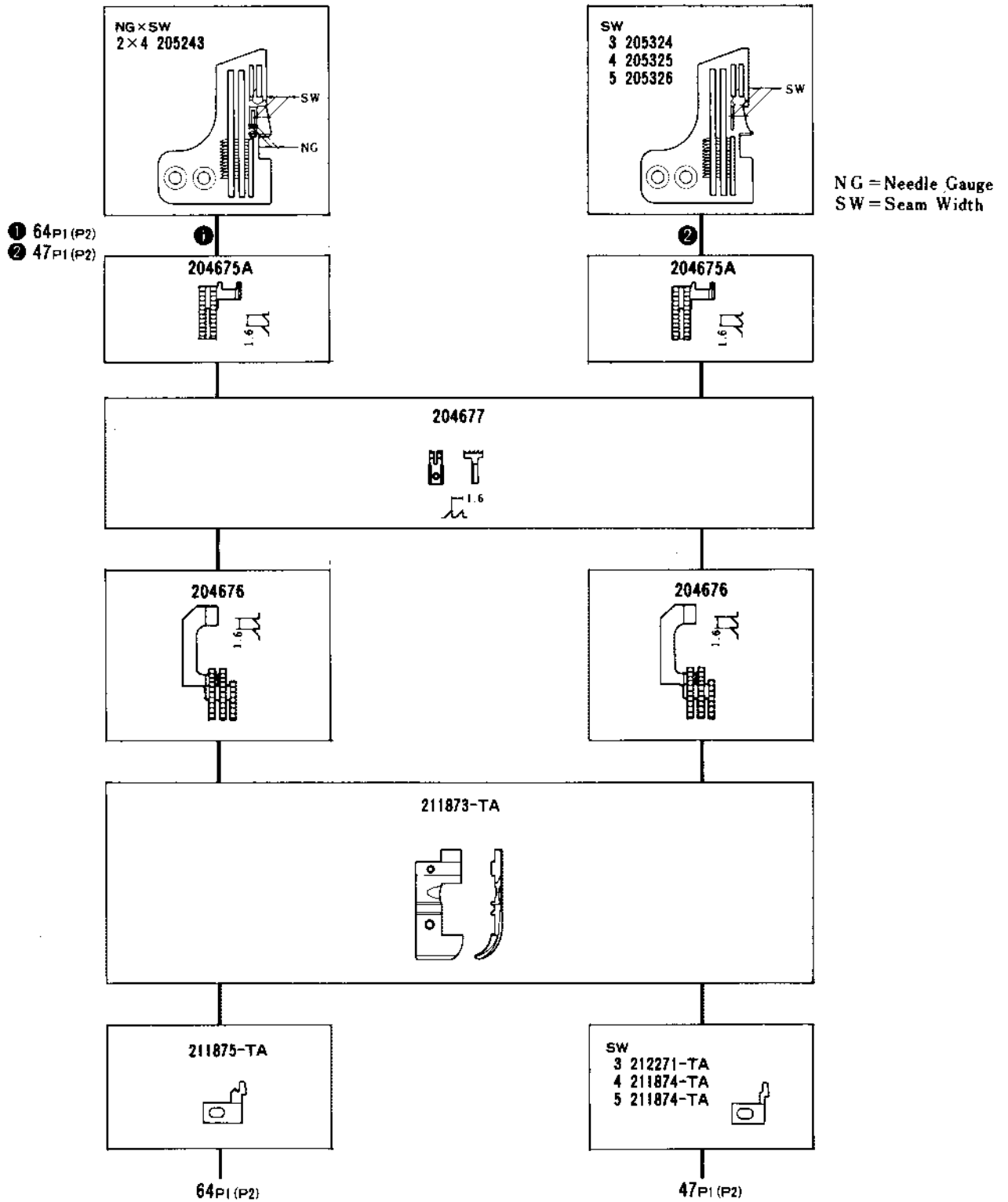

**GAUGE PARTS
CONSTRUCTION CHART**

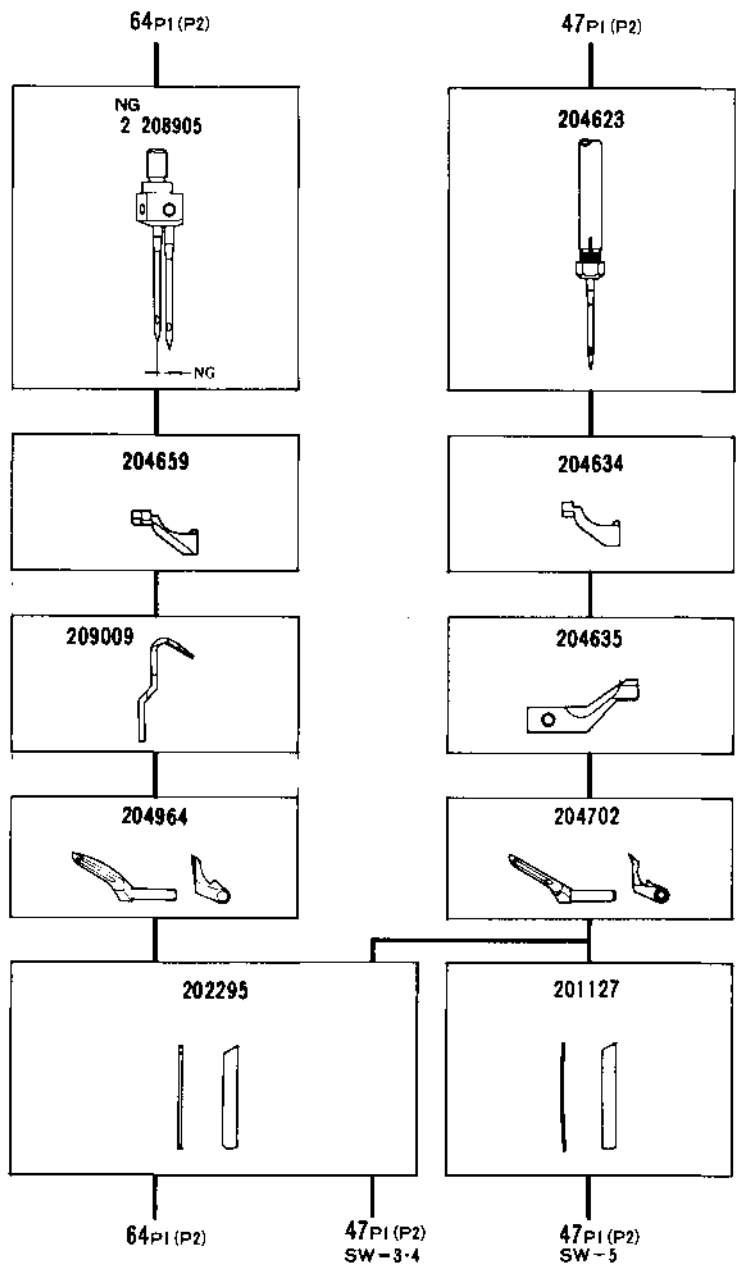
Feed pattern : 3-row

**514-4/64P1 (P2)
504-4/47P1 (P2)**





	 mm				MEMO	
514-4/64PI	2	4	514			For piping on medium weight fabrics such as knit shirts, sweat pants, pajamas and women's and kids' clothes.
514-4/64P2						
504-4/47PI		3,4,5	504			For piping on medium weight fabrics such as knit shirts, sweat pants, pajamas and women's and kids' clothes.
504-4/47P2						

• Variable feed : Intermittent differential feed type.





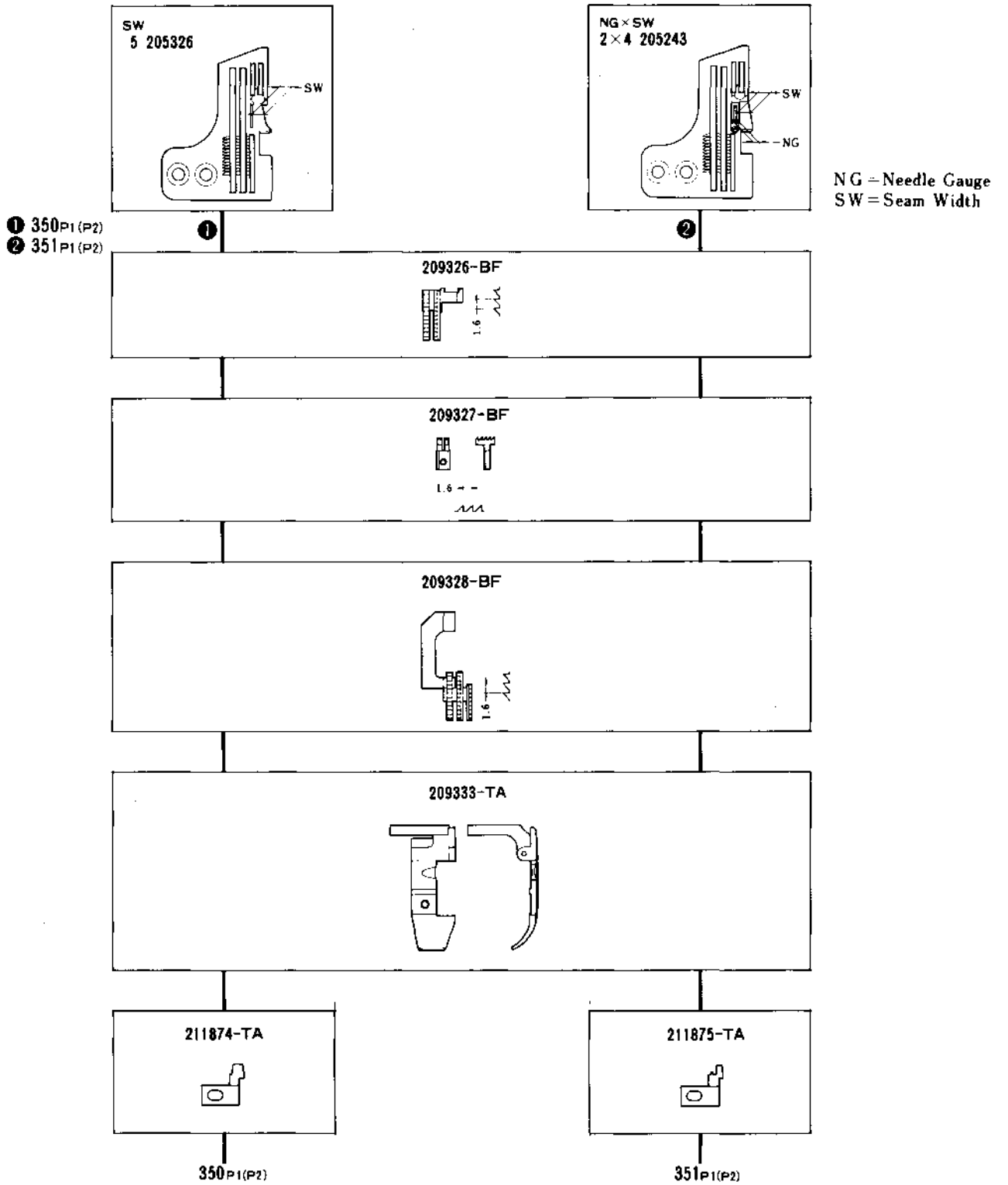

**GAUGE PARTS
CONSTRUCTION CHART**

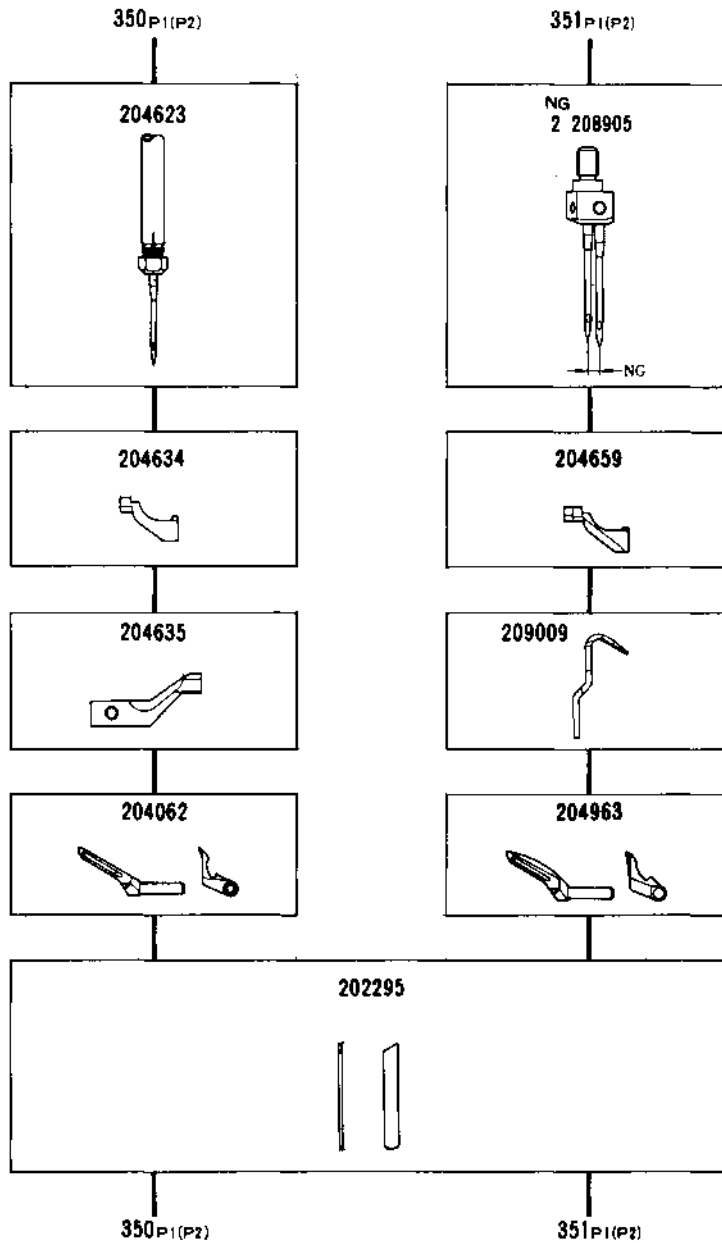
Feed pattern : 3-row

**504-4/350P1 (P2)
514-4/351P1 (P2)**





					MEMO	
504-4/350P1		5	504			For piping on medium weight fabrics such as knit shirts, sweat pants, pajamas and women's and kids' clothes.
504-4/350P2						
514-4/351P1	2	4	514			For piping on medium weight fabrics such as knit shirts, sweat pants, pajamas and women's and kids' clothes.
514-4/351P2						

• Variable feed : Intermittent differential feed type.

**GAUGE PARTS
CONSTRUCTION CHART**

**504-4/17
514-4/63
512-4/63**

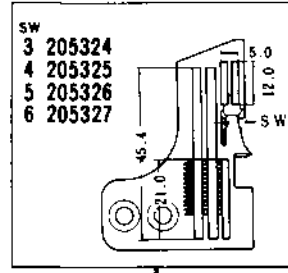
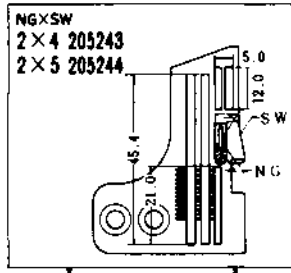

NG = Needle Gauge
SW = Seam Width

- ① 17
- ② 514-4/63
- ③ 512-4/63

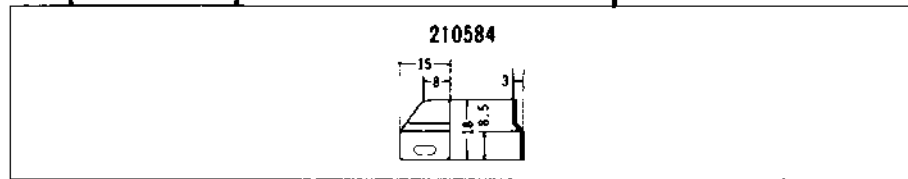
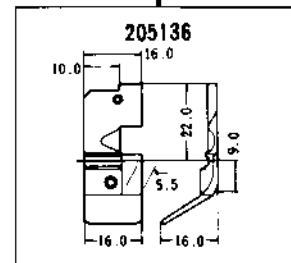
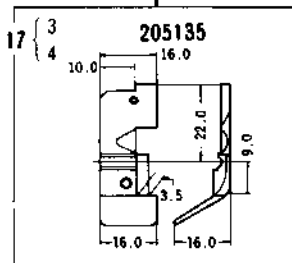
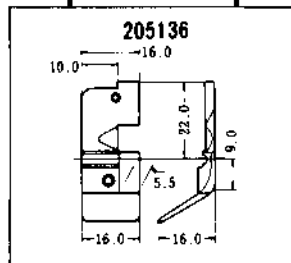
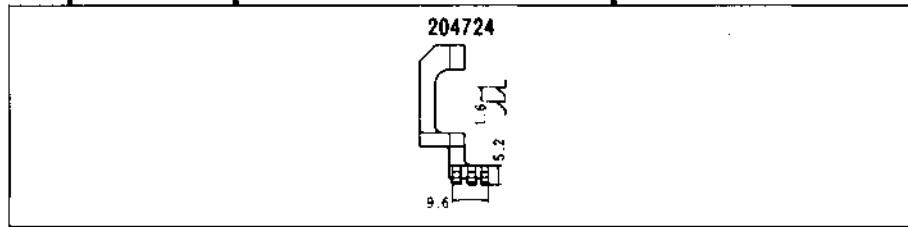
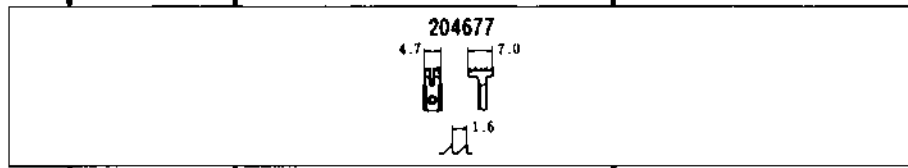
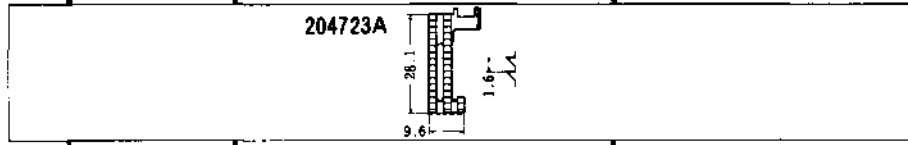

512-4/63

514-4/63

17

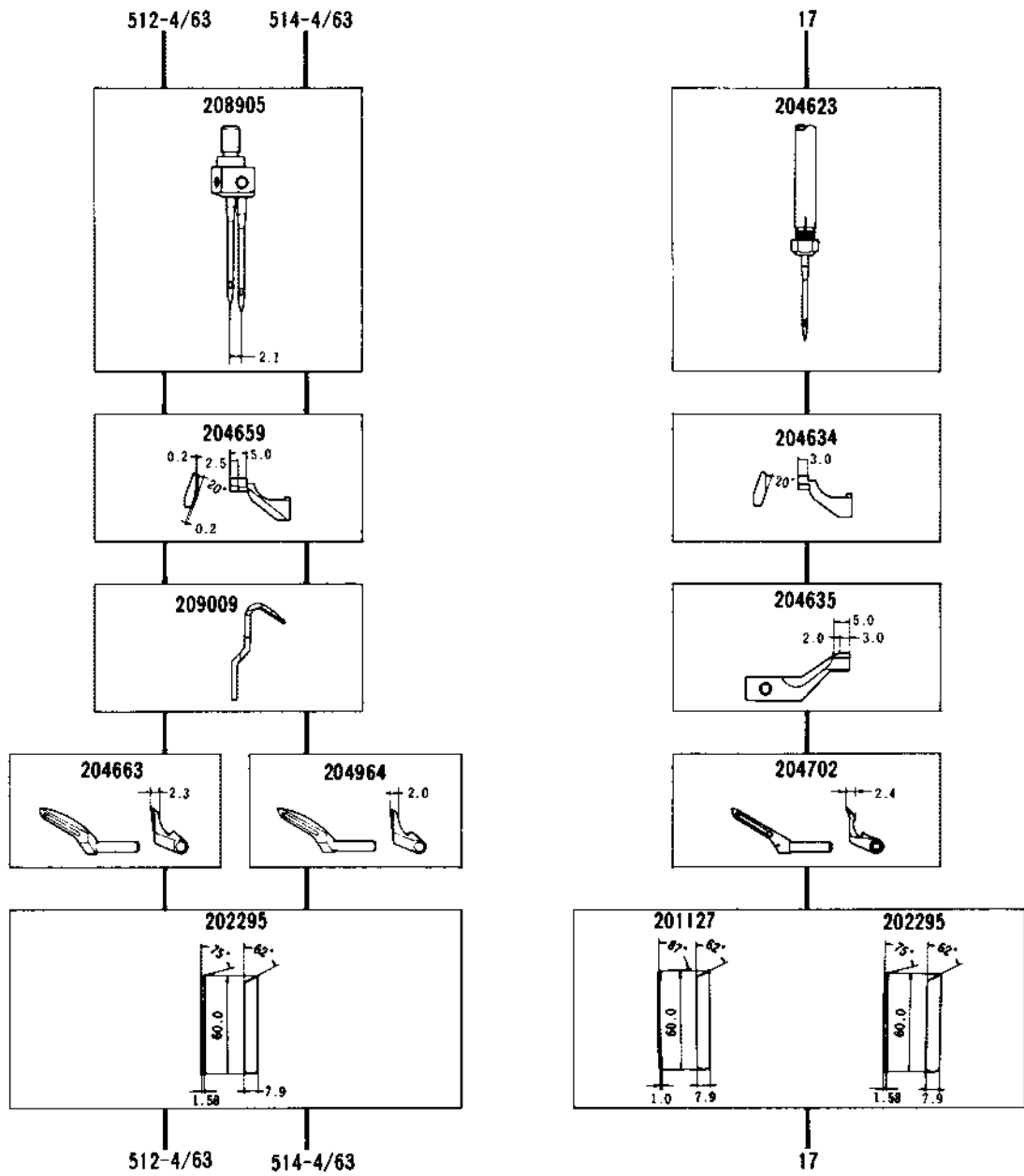



MACHINE	GAUGE		NEEDLE	MAIN	DIFF.	PRESSER FOOT		UPPER	UPPER	LOWER	401	(401) NEEDLE GUARD		NEEDLE	UPPER	LOWER	NEEDLE			
	TYPE	NG	SW	PLATE	FEED DOG	FEED DOG	COMP.	FAB. GRD.	LOOPER	SPREADER	LOOPER	LOOPER	FRONT	REAR	HOLDER	KNIFE	KNIFE	SIZE		
516(515) -4/26	2 3 4 5 6	3 4 5 6	204343A	208063	208215	208500	208531	204062 #2	204278 #1	204072	204314A	204536	204521	208908	201121A	204161	#11			
			204344A	"	"	"	"	"	"	"	"	"	"	"	"	"	"	"		
			204345A	"	"	"	"	"	"	"	"	"	"	"	"	"	"	"	"	
			204346A	"	"	"	"	"	"	"	"	"	"	"	"	"	"	"	"	
	3 4 5 6	3 4 5 6	204294B	208063	208215	208501	208531	204702 #4	204704 #3	204072	204314A	204536	204521	208909	201121A	204161	#14			
			204039B	"	"	"	"	"	"	"	"	"	"	"	"	"	"	"		
			204252B	"	"	"	"	"	"	"	"	"	"	"	"	"	"	"	"	
			204295B	"	"	"	"	"	"	"	"	"	"	"	"	"	"	"	"	
	5 5 5 6	3 4 5 6	204358A	208063	208215	208502	208531	204702 #4	204704 #3	204072	204431	204042	204522	208910	201121A	204161	#14			
			204359A	"	"	"	"	"	"	"	"	"	"	"	"	"	"	"		
			204360A	"	"	"	"	"	"	"	"	"	"	"	"	"	"	"	"	
			204361A	"	"	"	"	"	"	"	"	"	"	"	"	"	"	"	"	
516(515) -4/27	2 2 2 6	3 4 5 6	204362	208065	208218	208503	208531	204062 #2	204278 #1	204072	204314A	204536	205421	208908	202527A	204161	#11			
			204363	"	"	"	"	"	"	"	"	"	"	"	"	"	"	"		
			204364	"	"	"	"	"	"	"	"	"	"	"	"	"	"	"	"	
			204365	"	"	"	"	"	"	"	"	"	"	"	"	"	"	"	"	
	3 3 3 6	3 4 5 6	204366	208065	208218	208504	208531	204062 #2	204278 #1	204072	204314A	204536	205421	208909	202527A	204161	#11			
			204367	"	"	"	"	"	"	"	"	"	"	"	"	"	"	"		
			204368	"	"	"	"	"	"	"	"	"	"	"	"	"	"	"	"	
			204369	"	"	"	"	"	"	"	"	"	"	"	"	"	"	"	"	
	516(515) -4/28	2 2 2 6	3 4 5 6	204343A	208062	208216	208500	208531	204062 #2	204278 #1	204072	204314A	204536	205421	208908	201121A	204161	#11		
				204344A	"	"	"	"	"	"	"	"	"	"	"	"	"	"	"	
				204345A	"	"	"	"	"	"	"	"	"	"	"	"	"	"	"	"
				204346A	"	"	"	"	"	"	"	"	"	"	"	"	"	"	"	"
3 3 3 6		3 4 5 6	204294B	208062	208216	208501	208531	204062 #2	204278 #1	204072	204314A	204536	205421	208909	201121A	204161	#11			
			204039B	"	"	"	"	"	"	"	"	"	"	"	"	"	"	"		
			204252B	"	"	"	"	"	"	"	"	"	"	"	"	"	"	"	"	
			204295B	"	"	"	"	"	"	"	"	"	"	"	"	"	"	"	"	
516(515) -4/29		2 2 2 6	3 4 5 6	204362	208066	208219	208503	208531	204062 #2	204278 #1	204072	204314A	204536	204521	208908	202527A	204161	#11		
				204363	"	"	"	"	"	"	"	"	"	"	"	"	"	"	"	
				204364	"	"	"	"	"	"	"	"	"	"	"	"	"	"	"	"
				204365	"	"	"	"	"	"	"	"	"	"	"	"	"	"	"	"
	3 3 3 6	3 4 5 6	204366	208066	208219	208504	208531	204702 #4	204704 #3	204072	204314A	204536	204521	208909	202527A	204161	#14			
			204367	"	"	"	"	"	"	"	"	"	"	"	"	"	"	"		
			204368	"	"	"	"	"	"	"	"	"	"	"	"	"	"	"	"	
			204369	"	"	"	"	"	"	"	"	"	"	"	"	"	"	"	"	
	516(515) -4/30	2 2 2 6	3 4 5 6	204370	208069	208222	208500	208531	204062 #2	204278 #1	204072	204314A	204536	204521	208908	201121A	204161	#11		
				204371	"	"	"	"	"	"	"	"	"	"	"	"	"	"	"	
				204372	"	"	"	"	"	"	"	"	"	"	"	"	"	"	"	"
				204373	"	"	"	"	"	"	"	"	"	"	"	"	"	"	"	"
3 3 3 6		3 4 5 6	204374	208069	208222	208501	208531	204702 #4	204704 #3	204072	204314A	204536	204521	208909	201121A	204161	#14			
			204375	"	"	"	"	"	"	"	"	"	"	"	"	"	"	"		
			204376	"	"	"	"	"	"	"	"	"	"	"	"	"	"	"	"	
			204377	"	"	"	"	"	"	"	"	"	"	"	"	"	"	"	"	
5 5 5 6		3 4 5 6	204378	208063	208224	208502	208531	204702 #4	204704 #3	204072	204431	204042	204522	208910	201121A	204161	#14			
			204379	"	"	"	"	"	"	"	"	"	"	"	"	"	"	"		
			204380	"	"	"	"	"	"	"	"	"	"	"	"	"	"	"	"	
			204381	"	"	"	"	"	"	"	"	"	"	"	"	"	"	"	"	



MACHINE TYPE	GAUGE NG SW	NEEDLE PLATE	MAIN FEED DOG	DIFF. FEED DOG	PRESSER FOOT		UPPER LOOPER	UPPER SPREADER	LOWER LOOPER	401 LOOPER	(401) NEEDLE GUARD		NEEDLE HOLDER	UPPER KNIFE	LOWER KNIFE	NEEDLE SIZE	
					COMP.	FAB. GRD					FRONT	REAR					
516(515) -4/31	2 3	204370	208070	208223	208500	208531	204702 #4	204704 #3	204072	204314A	204536	204521	208908	201121A	204161	#16	
	2 4	204371	"	"	"	"	"	"	"	"	"	"	"	"	"	"	
	2 5	204372	"	"	"	"	"	"	"	"	"	"	"	"	"	"	
	2 6	204373	"	"	"	"	"	"	"	"	"	"	"	"	"	"	
	3 3	204374	208070	208223	208501	208531	204702 #4	204704 #3	204072	204314A	204536	204521	208909	201121A	204161	#16	
	3 4	204375	"	"	"	"	"	"	"	"	"	"	"	"	"	"	
	3 5	204376	"	"	"	"	"	"	"	"	"	"	"	"	"	"	
	3 6	204377	"	"	"	"	"	"	"	"	"	"	"	"	"	"	
	5 3	204378	208064	208225	208502	208531	204702 #4	204704 #3	204072	204431	204042	204522	208910	201121A	204161	#16	
	5 4	204379	"	"	"	"	"	"	"	"	"	"	"	"	"	"	
	5 5	204380	"	"	"	"	"	"	"	"	"	"	"	"	"	"	
	5 6	204381	"	"	"	"	"	"	"	"	"	"	"	"	"	"	
516(515) -4/32	3 3	204366	208067	208220	208504	208531	204702 #4	204704 #3	204072	204314A	204536	204521	208909	201121A	204161	#16	
	3 4	204367	"	"	"	"	"	"	"	"	"	"	"	"	"	"	
	3 5	204368	"	"	"	"	"	"	"	"	"	"	"	"	"	"	
516(515) -4/33	3 3	204294B	208064	208217	208501	208531	204702 #4	204704 #3	204072	204314A	204536	204521	208909	201121A	204161	#16	
	3 4	204039B	"	"	"	"	"	"	"	"	"	"	"	"	"	"	
	3 5	204252B	"	"	"	"	"	"	"	"	"	"	"	"	"	"	
	3 6	204295B	"	"	"	"	"	"	"	"	"	"	"	"	"	"	
	5 3	204358A	208064	208217	208502	208531	204702 #4	204704 #3	204072	204431	204042	204522	208910	201121A	204161	#16	
	5 4	204359A	"	"	"	"	"	"	"	"	"	"	"	"	"	"	
	5 5	204360A	"	"	"	"	"	"	"	"	"	"	"	"	"	"	
	5 6	204361A	"	"	"	"	"	"	"	"	"	"	"	"	"	"	
	516(515) -4/37	2 3	204370	208068	208221	208500	208531	204062 #2	204278 #1	204072	204314A	204536	204521	208908	201121A	204161	#11
		2 4	204371	"	"	"	"	"	"	"	"	"	"	"	"	"	"
		2 5	204372	"	"	"	"	"	"	"	"	"	"	"	"	"	"
		2 6	204373	"	"	"	"	"	"	"	"	"	"	"	"	"	"
3 3		204374	208068	208221	208501	208531	204062 #2	204278 #1	204072	204314A	204536	204521	208909	201121A	204161	#11	
3 4		204375	"	"	"	"	"	"	"	"	"	"	"	"	"	"	
3 5		204376	"	"	"	"	"	"	"	"	"	"	"	"	"	"	
3 6		204377	"	"	"	"	"	"	"	"	"	"	"	"	"	"	
516(515) -4/38	2 3	204935	208074	204420	208507	208532	204062 #2	204278 #1	204072	204314A	204536	204521	208908	201121A	204161	#11	
	2 4	204936	"	"	"	"	"	"	"	"	"	"	"	"	"	"	
	2 5	204937	"	"	"	"	"	"	"	"	"	"	"	"	"	"	
	2 6	204938	"	"	"	"	"	"	"	"	"	"	"	"	"	"	
	3 3	204939	208074	204420	208508	208532	204702 #4	204704 #3	204072	204314A	204536	204521	208909	201121A	204161	#14	
	3 4	204940	"	"	"	"	"	"	"	"	"	"	"	"	"	"	
	3 5	204941	"	"	"	"	"	"	"	"	"	"	"	"	"	"	
	3 6	204942	"	"	"	"	"	"	"	"	"	"	"	"	"	"	
	5 3	204943	208078	204422	208509	208532	204702 #4	204704 #3	204072	204431	204042	204522	208910	201121A	204161	#14	
	5 4	204944	"	"	"	"	"	"	"	"	"	"	"	"	"	"	
	5 5	204945	"	"	"	"	"	"	"	"	"	"	"	"	"	"	
	5 6	204946	"	"	"	"	"	"	"	"	"	"	"	"	"	"	



MACHINE TYPE	GAUGE		NEEDLE PLATE	MAIN FEED DOG	DIFF. FEED DOG	PRESSER FOOT		UPPER LOOPER	UPPER SPREADER	LOWER LOOPER	401 LOOPER	(401) NEEDLE GUARD		NEEDLE HOLDER	UPPER KNIFE	LOWER KNIFE	NEEDLE SIZE
	NG	SW				COMP.	FAB. GRD					FRONT	REAR				
516(515) -4/39	2	3	204935	208075	204421	208507	208532	204702 #4	204704 #3	204072	204314A	204536	204521	208908	201121A	204161	#16
	2	4	204936	"	"	"	"	"	"	"	"	"	"	"	"	"	"
	2	5	204937	"	"	"	"	"	"	"	"	"	"	"	"	"	"
	2	6	204938	"	"	"	"	"	"	"	"	"	"	"	"	"	"
	3	3	204939	208075	204421	208508	208532	204702 #4	204704 #3	204072	204314A	204536	204521	208909	201121A	204161	#16
	3	4	204940	"	"	"	"	"	"	"	"	"	"	"	"	"	"
	3	5	204941	"	"	"	"	"	"	"	"	"	"	"	"	"	"
	3	6	204942	"	"	"	"	"	"	"	"	"	"	"	"	"	"
	5	3	204943	208077	204423	208509	208532	204702 #4	204704 #3	204072	204431	204042	204522	208910	201121A	204161	#16
	5	4	204944	"	"	"	"	"	"	"	"	"	"	"	"	"	"
	5	5	204945	"	"	"	"	"	"	"	"	"	"	"	"	"	"
	5	6	204946	"	"	"	"	"	"	"	"	"	"	"	"	"	"
516(515) -4/51	5	5	204700	208064	208225	208955	204683	204703 #6	204705 #5	204072	204431-HC	204042	204522	208910	201121A	204161	#19
516(515) -4/52	5	5	204528	208064	208217	208955	204683	204703 #6	204705 #5	204072	204431-HC	204042	204522	208910	201121A	204161	#19
516(515) -4/91	8	5	208883	208063	208224	208888	-----	204702 #4	204704 #3	204072	204431	204042	204522	208966	201121A	204161	#9



MACHINE TYPE	GAUGE		NEEDLE PLATE	MAIN FEED DOG	DIFF. FEED DOG	PRESSER FOOT		UPPER LOOPER	UPPER SPREADER	LOWER LOOPER	401 LOOPER	(401) NEEDLE GUARD		NEEDLE HOLDER	UPPER KNIFE	LOWER KNIFE	NEEDLE SIZE
	NG	SW				COMP.	FAB. GRD					FRONT	REAR				
516-355	3	3	208674	208066	208219	208649	208531	204963 #8	-----	204072	204314A	204536	204521	208965	201121A	204161	#11
	3	4	208648	"	"	"	"	"	-----	"	"	"	"	"	"	"	"
516-555	5	3	208675	208063	208215	209255	208531	204963 #8	-----	204072	204431	204042	204522	209254	201121A	204161	#11
	5	4	208676	"	"	"	"	"	-----	"	"	"	"	"	"	"	"
516-359	3	3	208674	208066	208219	208649	208531	204702 #4	-----	204072	204314A	204536	204521	208965	201121A	204161	#11
	3	4	208648	"	"	"	"	"	-----	"	"	"	"	"	"	"	"
516-559	5	3	208675	208063	208215	209255	208531	204702 #4	-----	204072	204431	204042	204522	209254	201121A	204161	#11
	5	4	208676	"	"	"	"	"	-----	"	"	"	"	"	"	"	"



MACHINE TYPE	GAUGE		NEEDLE PLATE	MAIN FEED DOG	DIFF. FEED DOG	PRESSER FOOT		UPPER LOOPER	UPPER SPREADER	LOWER LOOPER	401 LOOPER	(401) NEEDLE GUARD		NEEDLE HOLDER	UPPER KNIFE	LOWER KNIFE	NEEDLE SIZE		
	NG	SW				COMP.	FAB. GRD					FRONT	REAR						
516(515) -4/38P1	3 3	4 5	204940 204941	208074 "	204420 "	204502A "	204460 "	204702 #4 "	204704 #3 "	204072 "	204314A "	204536 "	204521 "	208909 "	201121A "	204161 "	#14		
516(515) -4/38P2	3 3	4 5	204940 204941	208074 "	204420 "	204502A "	204460 "	204702 #4 "	204704 #3 "	204072 "	204314A "	204536 "	204521 "	208909 "	201121A "	204161 "	#14		
516(515) -4/39P1	3 3 3 3	3 4 5 6	204939 204940 204941 204942	208075 " " "	204421 " " "	208508 " " "	208532 " " "	204702 #4 " " "	204704 #3 " " "	204072 " " "	204314A " " "	204536 " " "	204521 " " "	208909 " " "	201121A " " "	204161 " " "	#16		
	5 5 5 5	3 4 5 6	204943 204944 204945 204946	208077 " " "	204423 " " "	208509 " " "	208532 " " "	204702 #4 " " "	204704 #3 " " "	204072 " " "	204431 " " "	204042 " " "	204522 " " "	208910 " " "	201121A " " "	204161 " " "	#16		
	516(515) -4/39P2	3 3 3 3	3 4 5 6	204939 204940 204941 204942	208075 " " "	204421 " " "	208508 " " "	208532 " " "	204702 #4 " " "	204704 #3 " " "	204072 " " "	204314A " " "	204536 " " "	204521 " " "	208909 " " "	201121A " " "	204161 " " "	#16	
		5 5 5 5	3 4 5 6	204943 204944 204945 204946	208077 " " "	204423 " " "	208509 " " "	208532 " " "	204702 #4 " " "	204704 #3 " " "	204072 " " "	204431 " " "	204042 " " "	204522 " " "	208910 " " "	201121A " " "	204161 " " "	#16	
		516 -4/550	3 3	4 5	209195 208993	208066 "	208219 "	208998 "	208531 "	204062 #2 "	----- "	204072 "	204314A "	204536 "	204521 "	208909 "	202527A "	204161 "	#11
			516 -4/551	3 3 5 5	4 5 4 5	209196 209197 209198 209199	208063 " " "	208215 " " "	209202 " 209204 "	208531 " " "	204062 #2 " " "	----- " " "	204072 " " "	204314A " 204431 "	204536 " 204042 "	204521 " 204522 "	208909 " 208910 "	201121A " " "	204161 " " "



MACHINE TYPE	GAUGE		NEEDLE	MAIN	AUX.	DIFF.	PRESSER FOOT				UPPER	LOWER	UPPER	LOWER	NEEDLE GUARD		NEEDLE	NEEDLE
	NG	SW	PLATE	FEED DOG	FEED DOG	FEED DOG	BODY	FINGER	FAB. GRD	UNCURLER	KNIFE	KNIFE	LOOPER	LOOPER	FRONT	REAR	BAR. COMP.	
505-4/25	2		202616	208090	204674	204730	201152E	201155C	-----	210584	201121A	202295	204062 #2	204072	204634	204635	204623	DCX27# 9
	3		202617	"	"	"	"	"	-----	"	"	"	"	"	"	"	"	
	4		202618	"	"	"	"	"	-----	"	"	"	"	"	"	"	"	
504-4/19	2		202616	208090	204674	204730	201473B	201224B	-----	210584	201121A	202295	204062 #2	204072	204634	204635	204623	DCX27# 9
	3		202617	"	"	"	"	"	-----	"	"	"	"	"	"	"	"	
	4		202618	"	"	"	"	"	-----	"	"	"	"	"	"	"	"	
503 4/44	3		205320	208334	208338	204907	202799	201224B	201265B	210584	201121A	202295	204704 #3	204072	204634	204635	204623	DCX27#14
	4		205321	"	"	"	"	"	"	"	"	"	"	"	"	"	"	
	5		205322	"	"	"	"	"	"	"	"	"	"	"	"	"	"	
504-4/16S2	1.5		205465	208911	208912	204730	201230C	205525	201265B	204668	201121A	202295	204062 #2	204072	204634	204635	204623	DCX27#11
	3		202542E	208078	204674	204676	201230C	201224B	201265B	204668	201121A	201127	204062 #2	204072	204634	204635	204623	
	4		202546E	"	"	"	"	"	"	"	"	202295	"	"	"	"	"	
503-4/48	3		205324	208335	208338	204690	202799	201224B	201265B	210584	201121A	201127	204704 #3	204072	204634	204635	204623	DCX27#14
	4		205325	"	"	"	"	"	"	"	"	"	"	"	"	"	"	
	5		205326	"	"	"	"	"	"	"	"	202295	"	"	"	"	"	
504-4/17	3		205324	208087	204677	204724	205135	-----	-----	210584	201121A	201127	204702 #4	204072	204634	204635	204623	DCX27#14
	4		205325	"	"	"	"	-----	-----	"	"	"	"	"	"	"	"	
	5		205326	"	"	"	205136	-----	-----	"	"	202295	"	"	"	"	"	
504-4/17	6		205327	"	"	"	"	-----	-----	"	"	"	"	"	"	"	"	



MACHINE TYPE	GAUGE		NEEDLE PLATE	MAIN FEED DOG	AUX. FEED DOG	DIFF. FEED DOG	PRESSER FOOT				UPPER KNIFE	LOWER KNIFE	UPPER LOOPER	LOWER LOOPER	NEEDLE GUARD		NEEDLE BAR. COMP.	NEEDLE
	NG	SW					BODY	FINGER	FAB. GRD	UNCURLER					FRONT	REAR		
504-4/66	3		202542E	208080	204674	204691	201230C	201224B	201265B	204668	201121A	201127	204702 #4	204072	204634	204635	204623	DCX27#14
	4		202546E	"	"	"	"	"	"	"	"	"	"	"	"	"	"	
	5		202596E	"	"	"	"	"	"	"	"	202295	"	"	"	"	"	
	6		202597E	"	"	"	"	"	"	"	"	"	"	"	"	"	"	
504-4/65	3		202542E	208080	204674	204679	201230C	201224B	201265B	204668	201121A	201127	204703 #6	204072	204634	204635	204623	DCX27#18
	4		202546E	"	"	"	"	"	"	"	"	"	"	"	"	"	"	
	5		202596E	"	"	"	"	"	"	"	"	202295	"	"	"	"	"	
	6		202597E	"	"	"	"	"	"	"	"	"	"	"	"	"	"	
	7		204797	"	"	"	"	"	"	"	"	"	"	"	"	"	"	
	8		204731	"	"	"	"	"	"	"	"	"	"	"	"	"	"	
504 4/69	3		202542E	208078	204674	204690	201230C	201224B	201265B	204668	201121A	201127	204062 #2	204072	204634	204635	204623	DCX27#11
	4		202546E	"	"	"	"	"	"	"	"	"	"	"	"	"	"	
	5		202596E	"	"	"	"	"	"	"	"	202295	"	"	"	"	"	
	6		202597E	"	"	"	"	"	"	"	"	"	"	"	"	"	"	
504-4/21	3		202542E	208086	204674	204724	205135	-----	-----	210584	201121A	201127	204062 #2	204072	204634	204635	204623	DCX27#11
	4		202546E	"	"	"	"	-----	-----	"	"	"	"	"	"	"	"	
	5		202596E	"	"	"	205136	-----	-----	"	"	202295	"	"	"	"	"	
	6		202597E	"	"	"	"	-----	-----	"	"	"	"	"	"	"	"	
504-4/43	3		205235	208085	204677	204722	205252	201224B	201265B	210584	201121A	201127	204702 #4	204072	204634	204635	204623	DCX27#14
	4		205236	"	"	"	"	"	"	"	"	"	"	"	"	"	"	
	5		205237	"	"	"	"	"	"	"	"	202295	"	"	"	"	"	
	6		205238	"	"	"	"	"	"	"	"	"	"	"	"	"	"	
504-4/45	3		205320	208083	204677	204693	202799	201224B	201265B	210584	201121A	201127	204702 #4	204072	204634	204635	204623	DCX27#14
	4		205321	"	"	"	"	"	"	"	"	"	"	"	"	"	"	
	5		205322	"	"	"	"	"	"	"	"	202295	"	"	"	"	"	
	6		205323	"	"	"	"	"	"	"	"	"	"	"	"	"	"	
504-4/47	3		205324	208079	204677	204676	205253	201224B	201265B	210584	201121A	201127	204702 #4	204072	204634	204635	204623	DCX27#16
	4		205325	"	"	"	"	"	"	"	"	"	"	"	"	"	"	
	5		205326	"	"	"	"	"	"	"	"	202295	"	"	"	"	"	
	6		205327	"	"	"	"	"	"	"	"	"	"	"	"	"	"	
504-4/260	5		209257	209293	204674	-----	209226	-----	-----	-----	201121A	202295	204703 #6	204072	204634	204635	204623	DCX27#18
	6		209224	"	"	-----	"	-----	-----	"	"	"	"	"	"	"	"	

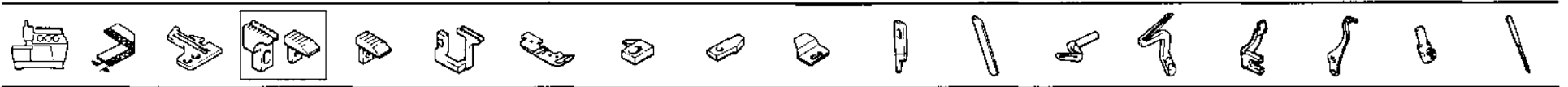

MACHINE TYPE	GAUGE		NEEDLE	MAIN	AUX.	DIFF.	PRESSER FOOT				UPPER	LOWER	UPPER	LOWER	NEEDLE GUARD		NEEDLE	NEEDLE
	NC	SW	PLATE	FEED DOG	FEED DOG	FEED DOG	BODY	FINGER	FAB. GRD	UNCURLER	KNIFE	KNIFE	LOOPER	LOOPER	FRONT	REAR	HOLDER	NEEDLE
514-4/68	2	2	208753	208078	204674	204690	208730	208731	208735	204668	201121A	201127	204963 # 8	204072	204659	209009	208905	DCX27#11
	2	3	205255	"	"	"	"	"	"	"	"	202295	"	"	"	"	"	"
	2	4	202554E	"	"	"	"	208732	"	"	"	"	"	"	"	"	"	"
514-4/61	2	2	208753	208078	204674	204676	208730	208731	208735	204668	201121A	201127	204949 #11	204072	204659	209009	208905	DCX27# 9
	2	3	205255	"	"	"	"	"	"	"	"	202295	"	"	"	"	"	"
	2	4	202554E	"	"	"	"	208732	"	"	"	"	"	"	"	"	"	"
514-4/18	2	2	208753	208078	204674	204690	208730	209171	208735	204668	201121A	201127	204663 # 7	204072	204659	209009	208905	DCX27#11
	2	3	205255	"	"	"	"	"	"	"	"	202295	"	"	"	"	"	"
	2	4	202554E	"	"	"	"	208651	"	"	"	"	"	"	"	"	"	"
514-4/18S1	2	2	208753	208080	204674	204691	208730	209171	208735	204668	201121A	201127	204990 #12	204991	204659	209009	208905	DCX27#14
	2	3	205255	"	"	"	"	"	"	"	"	202295	"	"	"	"	"	"
	2	4	202554E	"	"	"	"	208651	"	"	"	"	"	"	"	"	"	"
514-4/18S2	2	2	208753	208078	204674	204690	208730	209171	208735	204668	201121A	201127	204990 #12	204991	204659	209009	208905	DCX27#14
	2	3	205255	"	"	"	"	"	"	"	"	202295	"	"	"	"	"	"
	2	4	202554E	"	"	"	"	208651	"	"	"	"	"	"	"	"	"	"
514-4/67	2	2	208753	208080	204674	204691	208730	208731	208735	204668	201121A	201127	204964 # 9	204072	204659	209009	208905	DCX27#14
	2	3	205255	"	"	"	"	"	"	"	"	202295	"	"	"	"	"	"
	2	4	202554E	"	"	"	"	208732	"	"	"	"	"	"	"	"	"	"
514-4/73	2.5	2.5	208030	208093	204674	208044	208730	208733	208735	204668	201121A	201127	204964 # 9	204072	208051	209009	208906	DCX27#14
	2.5	4	208031	"	"	"	"	208734	"	"	"	202295	"	"	"	"	"	"
514-4/20	1.5	2	204910	208090	204674	204730	201230C	201396B	201265B	204668	201121A	202295	204949 #11	204072	204659	209009	208904	DCX3 # 9
	1.5	3	204911	"	"	"	"	"	"	"	"	"	"	"	"	"	"	"
	2	2	205256	"	"	"	"	"	"	"	"	"	"	"	"	"	208905	DCX27# 9
	2	3	205257	"	"	"	"	"	"	"	"	"	"	"	"	"	"	"
514-4/62	2	2	208753	208086	204674	204724	205136	-----	-----	210584	201121A	201127	204964 # 9	204072	204659	209009	208905	DCX27#14
	2	3	205255	"	"	"	"	-----	-----	"	"	202295	"	"	"	"	"	"
	2	4	205254E	"	"	"	"	-----	-----	"	"	"	"	"	"	"	"	"
514-4/64	2	4	205243	204679	204677	204676	205253	201310A	201265B	210584	201121A	202295	204964 # 9	204072	204659	209009	208905	DCX27#14
	2	5	205244	"	"	"	"	-----	-----	"	"	"	"	"	"	"	"	"
514-4/63	2	4	205243	208087	204677	204724	205136	-----	-----	210584	201121A	202295	204964 # 9	204072	204659	209009	208905	DCX27#14
	2	5	205244	"	"	"	"	-----	-----	"	"	"	"	"	"	"	"	"



MACHINE TYPE	GAUGE		NEEDLE	MAIN	AUX.	DIFF.	PRESSER FOOT				UPPER	LOWER	UPPER	LOWER	NEEDLE GUARD		NEEDLE	NEEDLE
	NC	SW	PLATE	FEED DOG	FEED DOG	FEED DOG	BODY	FINGER	FAB. CRD	UNCURLER	KNIFE	KNIFE	LOOPER	LOOPER	FRONT	REAR	HOLDER	NEEDLE
512-4/53	2	3	208322	208091	204674	208041	201230C	201396B	201265B	204668	201121A	201127	204702 # 4	204072	204659	209009	208905	DCX27#11
	2	4	208323	"	"	"	"	201310A	"	"	"	"	"	"	"	"	"	
	2	5	208324	"	"	"	"	"	"	"	"	202295	"	"	"	"	"	
	3	3	208033	"	"	"	"	208049	"	"	"	201127	"	"	208053	"	208907	
	3	4	208034	"	"	"	"	208050	"	"	"	202295	"	"	"	"	"	
3	5	208035	"	"	"	"	"	"	"	"	"	"	"	"	"	"	"	
512-4/61	2	2	208753	208078	204674	204676	201230C	201396B	201265B	204668	201121A	201127	204663 # 7	204072	204659	209009	208905	DCX27#14
	2	3	205255	"	"	"	"	"	"	"	"	202295	"	"	"	"	"	
	2	4	202554E	"	"	"	"	201310A	"	"	"	"	"	"	"	"	"	
	2	5	202499E	"	"	"	"	"	"	"	"	"	"	"	"	"	"	
512-4/73	2.5	2.5	208030	208093	204674	208044	201230C	208049	201265B	204668	201121A	201127	204663 # 7	204072	208051	209009	208906	DCX27#14
	2.5	4	208031	"	"	"	"	208050	"	"	"	202295	"	"	"	"	"	
	2.5	5	208032	"	"	"	"	"	"	"	"	"	"	"	"	"	"	
	3	3	208033	"	"	"	"	208049	"	"	"	201127	"	"	208053	"	208907	
	3	4	208034	"	"	"	"	208050	"	"	"	202295	"	"	"	"	"	
3	5	208035	"	"	"	"	"	"	"	"	"	"	"	"	"	"	"	
512-4/62	2	2	208753	208086	204674	204724	205136	-----	-----	210584	201121A	201127	204663 # 7	204072	204659	209009	208905	DCX27#14
	2	3	205255	"	"	"	"	-----	-----	"	"	202295	"	"	"	"	"	
	2	4	202554E	"	"	"	"	-----	-----	"	"	"	"	"	"	"	"	
	2	5	202499E	"	"	"	"	-----	-----	"	"	"	"	"	"	"	"	
512-4/64	2	4	205243	208079	204677	204676	205253	201310A	201265B	210584	201121A	202295	204663 # 7	204072	204659	209009	208905	DCX27#14
	2	5	205244	"	"	"	"	"	"	"	"	"	"	"	"	"	"	
512-4/57	2	3	208325	208092	208095	208041	202799	201396B	201265B	210584	201121A	201127	204663 # 7	204072	204659	209009	208905	DCX27#14
	2	4	208326	"	"	"	"	201310A	"	"	"	"	"	"	"	"	"	
	2	5	208327	"	"	"	"	"	"	"	"	202295	"	"	"	"	"	
	3	3	208036	"	"	"	205253	208049	"	"	"	201127	"	"	208053	"	208907	
	3	4	208037	"	"	"	"	208050	"	"	"	202295	"	"	"	"	"	
3	5	208038	"	"	"	"	"	"	"	"	"	"	"	"	"	"	"	
514-4/18S4	2	3	209387-30	209415-16	208095	209417-16	209386	201396B	208735	211600	211771	202295	209209	204991	204659	209009	208905	DCX27#14
	2	4	-40	"	"	"	"	201310A	"	"	"	"	"	"	"	"	"	
	2.5	2.5	209388-25	"	"	"	"	208049	"	"	"	"	204990	"	208051	"	208906	
	2.5	3.5	-35	"	"	"	"	"	"	"	"	"	"	"	"	"	"	
2.5	4.5	-45	"	"	"	"	208050	"	"	"	"	"	"	"	"	"	"	
514-4/18S5	2	3	209387-30	209415-16	208095	209417-16	209386	201396B	208735	211600	201121A	202295	209209	204991	204659	209009	208905	DCX27#14
	2	4	-40	"	"	"	"	201310A	"	"	"	"	"	"	"	"	"	
	2.5	2.5	209388-25	"	"	"	"	208049	"	"	"	"	204990	"	208051	"	208906	
	2.5	3.5	-35	"	"	"	"	"	"	"	"	"	"	"	"	"	"	
	2.5	4.5	-45	"	"	"	"	208050	"	"	"	"	"	"	"	"	"	
512-4/63	2	4	205243	208087	204677	204724	205136	-----	-----	210584	201121A	202295	204663 # 7	204072	204659	209009	208905	DCX27#14
	2	5	205244	"	"	"	"	-----	-----	"	"	"	"	"	"	"	"	
512-4/72	2	3	202982	208083	204677	204693	202799	201396B	201265B	210584	201121A	202295	204663 # 7	204072	204659	209009	208905	DCX27#14
	2	4	202983	"	"	"	"	201310A	"	"	"	"	"	"	"	"	"	

GAUGE PARTS LIST

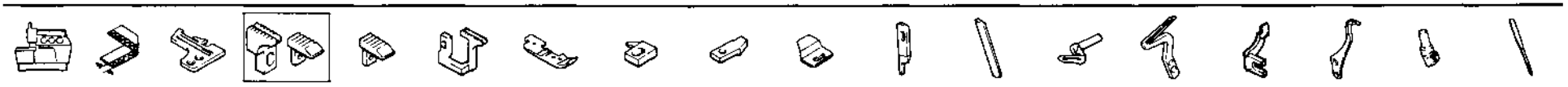

MACHINE TYPE	GAUGE		NEEDLE PLATE	MAIN FEED DOG	AUX. FEED DOG	DIFF. FEED DOG	PRESSER FOOT				UPPER KNIFE	LOWER KNIFE	UPPER LOOPER	LOWER LOOPER	NEEDLE GUARD		NEEDLE HOLDER	NEEDLE
	NG	SW					BODY	FINGER	FAB. GRD	UNCURLER					FRONT	REAR		
504-4/21P1 504-4/21P2	5		205326	208087	204677	204724	208783	-----	-----	210584	201121A	202295	204062 # 2	204072	204634	204635	204623	DCX27#11
514-4/62P1 514-4/62P2	2	3 4	209355 205243	208087 "	204677 "	204724 "	208782 "	----- "	----- "	210584 "	201121A "	202295 "	204964 # 9 "	204072 "	204659 "	209009 "	208905 "	DCX27#14
514-4/64P1 514-4/64P2	2	4	205243	208079	204677	204676	211873-TA	211875-TA	-----	-----	201121A	202295	204964 # 9	204072	204659	209009	208905	DCX27#14
504-4/47P1 504-4/47P2	3 4 5		205324 205325 205326	208079 " "	204677 " "	204676 " "	211873-TA " "	212271-TA 211874-TA "	----- ----- -----	----- ----- -----	201121A " "	201127 " 202295	204702 # 4 " "	204072 " "	204634 " "	204635 " "	204623 " "	DCX27#16
504-4/350P1 504-4/350P2	5		205326	209325-BF	209327-BF	209328-BF	209333-TA	211874-TA	-----	-----	201121A	202295	204062 # 2	204072	204634	204635	204623	DCX27#11
514-4/351P1 514-4/351P2	2	4	205243	209325-BF	209327-BF	209328-BF	209333-TA	211875-TA	-----	-----	201121A	202295	204963 # 8	204072	204659	209009	208905	DCX27#11

**NEEDLE SIZE AND
UPPER LOOPER/SPREADER**

Use Upper Looper/Spreader according to
the needle size and stitch type as shown.

STITCH TYPE	NEEDLE SIZE	PART NO.	USED FOR
503 515	9-12	204278 (#1)	2-thread L52.
	13-16	204704 (#3)	
	17-21	204705 (#5)	4-thread L32.
504 505 516	9-12	204062 (#2)	3-thread L52.
	13-16	204702 (#4)	
	17-21	204703 (#6)	5-thread L32.
514	9-12	204963 (#8)	2-needle L52.
	13-16	204964 (#9)	
	17-21	204965 (#10)	
512	9-12	204702 (#4)	2-needle L52 (mock-safety stitch)
	13-16	204663 (#7)	
	17-21	204949 (#11)	

**LIST OF THE COMPONENT PARTS
FOR MAIN FEED DOG COMPLETE**

**503-4. 504-4. 505-4.
512-4. 514-4.**

Main feed dog complete	Component parts		
	Main feed dog	Aux. feed dog	Screw
208078	204675A	204674	2922
208078-BF	204675A-BF	204674	"
208079	204675A	204677	"
208079-BF	204675A-BF	204677	"
208080	204678A	204674	"
208080-BF	204678A-BF	204674	"
208082-BF	204692A-BF	204674	"
208083	204692A	204677	"
208083-BF	204692A-BF	204677	"
208084	204694A	204677	"
208085-BF	204721A-BF	204677	"
208086	204723A	204674	"
208087	204723A	204677	"
208088	204725A	204677	"
208089	204727A	204677	"
208090-BF	204729A-BF	204674	"
208091	208039	204674	"
208092	208039	208095	"
208092-BF	208039A-BF	208095	"
208093-BF	208040-BF	204674	"
208167	208040	208095	"
208334	208336	208338	"
208335	208337	208338	"
208911	204729A	208912	"
209293	209225	204674	"
209325-BF	209326-BF	209327-BF	"
209329-BF	209330-BF	209327-BF	"
209383-BF	209384-BF	208095	"
210415-16	209416-16	208095	"

515-4. 516-4.

Main feed dog complete	Component parts		
	Main feed dog	Aux. feed dog	Screw
208062	204125B	204424	2922
208063	204248B	208059	"
208064	204394	208059	"
208065	204395	204425	"
208066	204396	208060	"
208067	204397	208060	"
208068	204398	204427	"
208069	204399	208061	"
208070	204400	208061	"
208071	204401	204424	"
208072	204402	208059	"
208073	204403	208059	"
208074	204931	208061	"
208075	204932	208061	"
208076	204933	208059	"
208077	204934	208059	"

INDEX

PART NO.	PAGE	NO. REF.	PART NO.	PAGE	NO. REF.	PART NO.	PAGE	NO. REF.	PART NO.	PAGE	NO. REF.	PART NO.	PAGE	NO. REF.
DCX27	17	33	413	51	18	2022	3	20	4818	55	38	5137	63	12
DCX27	17	34	413	53	32	2022	11	19	4904	67	12	5138B	47	25
DCX27	71	21	413	55	41	2022-4	13	12	4905	67	16	5141	37	6
DCX27	71	22	452	71	1	2022-4	13	15	4908	51	17	5142	21	33
DCX27	71	25	467	57	18	2022-4	15	12	4908	53	31	5142	61	45
DCX27 # 9	130		468	57	20	2022-4	15	15	4908	55	40	5143A	19	8
DCX27 #11	128		480	71	18	2022-4	17	13	4911	57	10	5143A	21	8
DCX27 #11	129		482	71	27	2022-4	41	12	5001	39	7	5145	47	11
DCX27 #11	130		484	71	3	2133-1	35	25	5002	7	10	5146	7	23
DCX27 #11	131		485	71	2	2133-1	41	20	5002	39	34	5147	7	15
DCX27 #11	132		486A9C	69		2193	23	20	5003	43	5	5150B	47	27
DCX27 #14	128		486B9C	69		2193	27	22	5010	19	44	5152	5	2
DCX27 #14	129		486C9C	69		2193	39	38	5010	49	22	5152	59	6
DCX27 #14	130		502-CA	69	15	2193	43	16	5012	19	36	5157	33	28
DCX27 #14	131		503-CA	69	1	2193	43	26	5012	25	11	5157	45	16
DCX27 #14	132		504-CA	69	16	2193	53	7	5012	49	15	5163	3	7
DCX27 #16	129		505-CA	69	4	2193	55	7	5022	9	15	5182	9	27
DCX27 #16	132		505ACA	69	5	2193	55	27	5029	19	39	5183	65	23
DCX27 #18	129		506	69	33	2193	61	6	5029	37	5	5184	53	10
DCX27 #9	128		507	69	10	2193	63	18	5029	41	31	5184	55	10
DCX3	71	26	509	69	2	2213	63	9	5029	59	20	5184	61	9
DCX3 # 9	130		512	69	13	2902	7	8	5030	43	38	5205	35	42
W09070-2	17	47	527-CA	69	31	2902	23	26	5030	45	9	5205	35	44
127	71	10	527ACA	69	32	2902	27	32	5053	9	37	5210	51	6
128	71	11	909	71	28	2905	7	13	5053	17	29	5210	59	42
131	71	16	1170	63	24	2905	25	9	5060	47	9	5227	19	33
153	71	17	1170-1	11	23	2905	57	7	5064	63	6	5227	19	41
178	71	4	1170-1	47	17	2905	61	22	5077	31	33	5227	63	3
179	71	12	1170-1	63	37	2913-2	41	6	5077	51	27	5231	35	15
182	71	14	1170-3	17	25	2921	23	28	5078	3	2	5231	35	39
189	57	12	1175-2	11	33	2921	41	27	5080	11	2	5232	9	43
192	65	20	1175-2	25	5	2921	43	19	5081	11	3	5232	41	10
193	65	21	1175-2	35	23	2921	43	43	5082A	19	12	5233	13	6
194	65	22	1175-2	39	13	2921	45	7	5082A	21	11	5233	13	8
195	65	28	1175-2	39	32	2921	45	12	5082A	23	10	5233	15	7
196	65	30	1175-2	65	14	2921	45	34	5082A	27	10	5233	15	9
197	65	31	1175-3	5	38	2921	45	36	5082A	59	32	5234	17	3
198	65	35	1175-3	7	17	2921	51	24	5084	25	27	5237	3	6
199	65	36	1175-3	21	40	2922	5	25	5084	29	8	5239	25	22
200	71	15	1175-3	27	29	2922	29	28	5084	29	18	5240	11	24
233-CA	69	23	1175-3	35	34	2922	35	22	5084	31	14	5242	49	2
272	67	8	1175-3	61	30	2922	43	7	5084	33	6	5259	31	25
283	71	8	1175-3	63	34	2922	65	41	5084	35	2	5260	39	22
284	71	7	1186	17	49	2922	133		5084	35	27	5267	11	7
285	71	6	1189	29	26	3044	5	9	5084	37	14	5271	41	37
286	71	5	1189	35	35	3044	7	11	5088	39	18	5276	63	29
293A	69	26	1189	61	16	3044	41	38	5089	43	35	5284	27	25
293B	69	27	1196	43	25	3044	53	12	5089	45	29	5284	29	23
293C	69	28	1196	55	18	3044	55	12	5089	55	26	5286	25	23
322	71	13	1202	9	9	3044	61	11	5091	5	12	5291	45	20
337	57	8	1202	41	9	3044	65	24	5091	9	24	5292	17	18
338	57	15	1202	51	3	3056	31	6	5091	9	30	5292	17	35
339	57	16	1202	53	13	3091	5	39	5091	21	35	5292	17	40
339	57	21	1202	55	13	3091	43	13	5091	21	37	5292	17	50
340	57	17	1202	59	44	3091	47	18	5091	31	3	5292	29	5
341	57	11	1202	61	12	3091	61	32	5094	7	2	5292	31	27
343	57	19	1206	19	43	3091	63	25	5094	7	25	5292	33	11
344	57	9	1206	21	42	3119	17	37	5094	47	22	5292	59	26
380A	69	6	1206	21	44	3150	45	24	5104	59	10	5299	61	25
381-CA	69	9	1206	49	23	4009-1	5	15	5104	59	23	5304	11	20
382-CA	69	11	1206	59	12	4009-1	5	22	5104	65	9	5312	17	14
383-CA	69	19	1206	59	14	4009-1	5	32	5107	19	34	5316	37	9
384	69	20	1216	7	20	4009-1	7	4	5113	9	26	5317	35	30
386	69	36	1216	9	5	4009-1	19	20	5113	19	28	5317	41	16
391	71	9	1216	37	23	4009-1	21	18	5113	21	26	5321A	37	29
392	71	19	1216	57	3	4009-1	31	30	5113	31	29	5326	63	11
403	51	7	1216	61	34	4009-1	35	11	5113	31	34	5328	7	6
403	53	21	1229	63	15	4009-1	39	26	5117	3	12	5328	17	8
403	55	30	1231	43	41	4009-1	49	13	5117	5	19	5328	29	17
404	51	10	1234	5	30	4009-1HC	21	28	5117	11	13	5328	43	31
404	53	24	1234	59	39	4012	51	11	5117	39	29	5328	45	10
404	55	33	1234	63	39	4012	53	25	5117	39	39	5328	45	18
405	51	9	1333	53	20	4012	55	34	5117	53	15	5328	45	32
405	53	23	1333	61	38	4012	69	24	5117	55	15	5328	47	15
405	55	32	1435	9	33	4012	69	29	5117	61	4	5328	51	28
406	51	8	1435	59	25	4014	69	21	5117	63	21	5328	59	16
406	53	22	1457	9	13	4021	69	17	5117	63	23	5332A	3	14
406	55	31	1457	17	20	4022	69	14	5117	65	6	5336	33	23
407	51	12	1457	31	5	4117	69	34	5117	65	43	5341	65	37
407	53	26	1457	41	18	4512	67	7	5118	37	21	5345	49	11
407	55	35	1457-1	41	25	4802	29	9	5118	37	26	5345	49	31
408	51	13	1457-1	59	19	4803	69	8	5118	41	2	5346	35	48
408	53	27	1458	39	4	4803	69	22	5118	49	3	5347	65	32
408	55	36	1459	9	34	4803	69	25	5118	59	36	5348	65	33
409	51	14	1459	13	4	4803	69	30	5118	63	27	5357	21	31
409	53	28	1459	15	5	4805	57	14	5118	65	26	5359	17	43
409	55	37	1459	65	12	4805	69	18	5137	7	26	5361	11	29
410	51	16	1732	9	18	4805	69	35	5137	19	14	5362	9	40
410	53	30	1732-HC	19	30	4818	51	15	5137	19	17	5371	61	43
410	55	39	1998-2	25	16	4818	53	29	5137	21	15	5376	13	10

INDEX

PART NO.	PAGE	NO. REF.	PART NO.	PAGE	NO. REF.	PART NO.	PAGE	NO. REF.	PART NO.	PAGE	NO. REF.	PART NO.	PAGE	NO. REF.
5376	13	14	201121A	126		202546E	128		204107	23	19	204366	125	
5376	15	11	201121A	127		202546E	129		204107	27	20	204367	124	
5376	15	14	201121A	128		202554E	130		204107	35	10	204367	125	
5380	65	8	201121A	129		202554E	131		204111A	35	12	204368	124	
5381	17	6	201121A	130		202576	9	11	204114	35	13	204368	125	
5381	33	4	201121A	131		202588	43	36	204114	35	37	204369	124	
5381	35	6	201121A	132		202588	51	21	204115	35	14	204369	125	
5381	37	7	201127	39	36	202588	55	25	204115	35	38	204370	124	
5381	37	12	201127	71	23	202596E	128		204122	35	36	204370	125	
5381	39	2	201127	128		202596E	129		204123A	35	18	204371	124	
5385	29	2	201127	129		202597E	128		204124	35	31	204371	125	
5408	25	4	201127	130		202597E	129		204125B	133		204372	124	
5409	43	9	201127	131		202616	128		204128A	35	26	204372	125	
5409	45	4	201127	132		202617	128		204129A	35	24	204373	124	
5427	33	12	201139	9	12	202618	128		204139A	37	11	204373	125	
5427	43	8	201152E	128		202645	41	32	204140A	37	8	204374	124	
5437	33	18	201155C	128		202647A	41	29	204142B	37	24	204374	125	
5455	31	21	201156	43	34	202653	5	28	204143A	37	25	204375	124	
5455	35	9	201185	43	17	202683	41	1	204145A	13	7	204375	125	
5457	29	12	201185	43	27	202683	65	42	204145A	15	8	204376	124	
5457	31	18	201185	49	32	202689	5	29	204146	39	3	204376	125	
5461	33	15	201185	55	28	202705A	17	42	204147	39	1	204377	124	
5461	33	29	201191	53	11	202706A	17	48	204149	39	9	204377	125	
5476	69	3	201191	55	11	202757	65	45	204152	61	41	204378	124	
5482	5	16	201191	61	10	202757A	41	15	204154	39	14	204378	125	
5501	19	46	201211B	61	17	202799	128		204155	61	46	204379	124	
5501	21	46	201224B	128		202799	129		204156	61	47	204379	125	
5513	59	8	201224B	129		202799	131		204158	39	27	204380	124	
5538	43	12	201230C	128		202849	21	13	204159	39	28	204380	125	
5546	23	13	201230C	129		202849	23	11	204160A	39	30	204381	124	
5546	27	13	201230C	130		202849	27	11	204161	39	19	204381	125	
5549	11	4	201230C	131		202849	31	11	204161	71	20	204394	133	
5552	43	21	201233A	61		202868	37	27	204161	124		204395	133	
7102	69	12	201252	69	7	202875	23	29	204161	125		204396	133	
9050	67	13	201265B	128		202875	45	17	204161	126		204397	133	
137142	61	23	201265B	129		202875	51	25	204161	127		204398	133	
137142	65	25	201265B	130		202875	73	12	204162	39	21	204399	133	
137142	65	27	201265B	131		202903	47	4	204172	29	27	204400	133	
137906	5	40	201310A	130		202982	131		204177B	41	8	204401	133	
137906	59	40	201310A	131		202983	131		204178	41	7	204402	133	
137906	61	31	201323	47	3	204003	3	16	204185	47	21	204403	133	
137906	61	35	201360B	17	4	204006	3	19	204186A	11	18	204420	125	
137906	63	40	201395	41	33	204010	11	26	204187	47	8	204420	127	
167066	51	4	201396B	130		204014	11	25	204193	47	1	204421	126	
167066	53	14	201396B	131		204016	11	22	204194	47	5	204421	127	
167066	55	14	201441B	17	5	204018	11	16	204198	11	8	204422	125	
167066	59	45	201473B	128		204019A	11	15	204218	9	3	204423	126	
167066	63	35	201485	61	8	204020A	11	14	204223	5	31	204423	127	
167072	31	10	201523A	11	17	204022	11	12	204242	9	14	204424	133	
167077	31	7	201629	9	21	204023	11	5	204243	9	16	204425	133	
167079	31	2	201758	47	6	204026	11	6	204248B	133		204427	133	
198192	5	33	202045	25	24	204029	13	5	204251	3	4	204431	124	
200030	17	21	202176	17	17	204029	15	6	204252B	124		204431	125	
200041	17	45	202176	25	20	204039B	124		204252B	125		204431	126	
200098	5	10	202176	25	26	204039B	125		204259	49	16	204431	127	
200098	39	23	202176	29	16	204042	124		204274	25	17	204431-HC	126	
200136	49	7	202176	49	5	204042	124		204278	133		204435	49	17
200152	47	2	202176	49	25	204042	126		204278 #1	124		204439A	35	29
200152	49	8	202199	49	12	204042	127		204278 #1	125		204449	61	1
200155	49	6	202281	73	11	204048A	13	16	204293	27	26	204451	53	6
200155	49	26	202286	7	9	204048A	15	18	204293	29	13	204451	55	6
200162A	9	4	202286	23	14	204052A	23	15	204293	29	24	204451	61	3
200183	63	16	202286	23	21	204052A	37	18	204294B	124		204451	63	20
200555	7	22	202286	27	14	204055B	25	21	204294B	125		204452	53	5
200555	19	27	202286	27	21	204062	133		204295B	124		204452	55	5
200555	21	25	202286	53	8	204062 #2	124		204295B	125		204452	61	5
200654	17	16	202286	55	8	204062 #2	125		204314A	124		204460	51	26
200821	7	18	202286	61	7	204062 #2	127		204314A	125		204460	127	
201002	3	3	202286	63	13	204062 #2	128		204314A	126		204466	49	20
201002	3	10	202286	63	19	204062 #2	129		204314A	127		204495	63	17
201037	19	4	202287A	47	26	204062 #2	132		204319	11	32	204499	73	2
201037	21	4	202295	39	35	204072	124		204324	31	32	204500	73	2
201048A	23	1	202295	71	24	204072	125		204343A	124		204501	73	2
201048A	27	1	202295	128		204072	126		204344A	124		204502	73	3
201048A	31	1	202295	129		204072	127		204345A	124		204502A	51	22
201056	31	13	202295	130		204072	128		204346A	124		204502A	127	
201056	35	1	202295	131		204072	129		204351	39	20	204503	73	3
201056	41	17	202295	132		204072	130		204358A	124		204504	73	3
201068	19	10	202451	41	26	204072	131		204358A	125		204505	73	4
201068	21	10	202495	17	44	204072	132		204359A	124		204506	73	4
201068	23	6	202499E	131		204084	33	7	204359A	125		204507	73	4
201072A	23	2	202522	33	34	204085	33	2	204360A	124		204508	73	5
201072A	27	2	202522	37	10	204089	31	15	204360A	125		204509	73	5
201074A	23	12	202522	65	29	204091	59	31	204361A	124		204510	73	5
201074A	27	12	202526	3	23	204093	39	22	204361A	125		204511	73	6
201086	27	6	202527A	39	17	204095A	31	26	204362	124		204512	73	6
201117	17	7	202527A	124		204096	31	31	204363	124		204513	73	6
201121A	39	16	202527A	127		204097A	31	28	204364	124		204514	73	7
201121A	124		202542E	128		204099	31	4	204365	124		204515	73	7
201121A	125		202542E	129		204100	33	1	204366	124		204516	73	7

INDEX

PART NO.	PAGE	NO. REF.	PART NO.	PAGE	NO. REF.	PART NO.	PAGE	NO. REF.	PART NO.	PAGE	NO. REF.	PART NO.	PAGE	NO. REF.
204521	124		204702	133		204892	65	15	205135	128		208030	130	
204521	125		204702 #4	124		204893	65	16	205135	129		208030	131	
204521	126		204702 #4	125		204894	65	17	205136	128		208031	130	
204521	127		204702 #4	126		204895	65	18	205136	129		208031	131	
204522	124		204702 #4	127		204896	61	13	205136	130		208032	131	
204522	125		204702 #4	128		204897	65	1	205136	131		208033	131	
204522	126		204702 #4	129		204898	65	2	205137	63	32	208034	131	
204522	127		204702 #4	131		204901	27	30	205216A	5	11	208035	131	
204528	126		204702 #4	132		204902	23	27	205217	5	13	208036	131	
204529	126		204703	133		204903	25	10	205235	129		208037	131	
204536	124		204703 #6	126		204905	25	7	205236	129		208038	131	
204536	125		204703 #6	129		204906	73	10	205237	129		208039	133	
204536	126		204704	133		204907	128		205238	129		208039A-BF	133	
204536	127		204704 #3	124		204910	130		205243	130		208040	133	
204585	63	30	204704 #3	125		204911	130		205243	131		208040-BF	133	
204585	65	34	204704 #3	126		204913	128		205243	132		208041	131	
204588	35	17	204704 #3	127		204921	49	4	205244	130		208044	130	
204592	63	26	204704 #3	128		204921	49	24	205244	131		208044	131	
204593	47	7	204705	133		204929	41	4	205252	129		208049	131	
204618	35	16	204705 #5	126		204930	41	3	205253	129		208050	131	
204623	17	36	204706	17	41	204931	133		205253	130		208051	130	
204623	128		204707	17	51	204932	133		205253	131		208051	131	
204623	129		204721A-BF	133		204933	133		205255	130		208053	131	
204623	132		204722	129		204934	133		205255	131		208056	7	33
204625A	17	22	204723A	133		204935	125		205256	130		208058	7	32
204627A	17	25	204724	128		204935	126		205257	130		208059	133	
204630	21	30	204724	129		204936	125		205319	61	36	208060	133	
204631	21	32	204724	130		204936	126		205320	128		208061	133	
204634	128		204724	131		204937	125		205320	129		208062	124	
204634	129		204724	132		204937	126		205321	128		208063	124	
204634	132		204725A	133		204938	125		205321	129		208063	126	
204635	128		204727A	133		204938	126		205322	128		208063	127	
204635	129		204729A	133		204939	125		205322	129		208064	125	
204635	132		204729A-BF	133		204939	126		205323	128		208064	126	
204636	21	38	204730	128		204939	127		205323	129		208065	124	
204636A	21	39	204730	130		204940	125		205324	128		208066	124	
204638	39	12	204731	129		204940	126		205324	129		208066	126	
204646	5	23	204737	11	31	204940	127		205324	132		208066	127	
204650A	7	1	204742	9	39	204941	125		205325	128		208067	125	
204651	49	18	204743	9	10	204941	126		205325	129		208068	125	
204659	130		204744	9	8	204941	127		205325	132		208069	124	
204659	131		204745	9	41	204942	125		205326	128		208070	125	
204659	132		204746	9	35	204942	126		205326	129		208074	125	
204663	133		204747	9	36	204942	127		205326	132		208074	127	
204663 #7	130		204748	9	38	204943	125		205327	128		208075	126	
204663 #7	131		204749	9	32	204943	126		205327	129		208075	127	
204664	27	23	204750	21	29	204943	127		205421	124		208076	125	
204667	61	14	204751	35	4	204944	125		205456	61	21	208077	126	
204668	128		204752	37	19	204944	126		205457	61	18	208077	127	
204668	129		204754A	37	13	204944	127		205465	128		208078	128	
204668	130		204755	37	20	204945	125		205466	67	9	208078	129	
204668	131		204756	37	16	204945	126		205467	67	3	208078	130	
204670	63	1	204757	37	15	204945	127		205468-JA	67	14	208078	131	
204674	128		204760A	61	15	204946	125		205469-JA	67	15	208079	129	
204674	129		204762	21	36	204946	126		205470-JA	67	11	208079	131	
204674	130		204781	19	35	204946	127		205473	67	10	208079	132	
204674	131		204782	19	37	204949	133		205495	17	2	208080	129	
204674	133		204783	19	31	204949 #11	130		205495	33	5	208080	130	
204675A	133		204787	15	16	204960	65	39	205525	128		208083	129	
204675A-BF	133		204788	13	17	204961	65	44	205678	61	19	208083	131	
204676	128		204788	15	17	204962	65	40	205679	61	20	208085	129	
204676	129		204788	15	19	204963	133		205685	5	37	208086	129	
204676	130		204796	39	15	204963 #8	126		205764	67	5	208086	130	
204676	131		204797	129		204963 #8	130		205765	67	6	208086	131	
204676	132		204806	47	28	204963 #8	132		205835	61	24	208087	128	
204677	128		204810	35	40	204964	133		205857	35	28	208087	130	
204677	129		204827	9	31	204964 #9	130		206181B	39	6	208087	131	
204677	130		204828	3	15	204964 #9	132		206225	59	18	208087	132	
204677	131		204830	61	44	204965	133		206336	67	1	208090	128	
204677	132		204835	61	42	204966	65	19	206337	67	2	208090	130	
204677	133		204848A	5	21	204990	73	8	206337	67	4	208091	131	
204678A	133		204857A-FA	9	29	204990	131		206457	5	5	208092	131	
204678A-BF	133		204862	49	29	204990 #12	130		206682	5	6	208093	130	
204679	129		204865AFA	9	23	204991	73	9	206781	33	22	208093	131	
204679	130		204867	9	25	204991	130		206781	49	30	208095	131	
204681	5	24	204868	7	7	204991	131		207358	11	21	208095	133	
204683	45	15	204870	37	28	205015	31	22	208001-FD	7	16	208096	39	31
204683	126		204873	11	28	205064	63	2	208003	7	28	208108	35	41
204690	128		204874	31	12	205065	63	4	208004	7	29	208109	35	46
204690	129		204881	11	30	205066	63	5	208005	7	30	208168	35	45
204690	130		204882	63	31	205067	63	7	208006	7	31	208169A	3	9
204691	129		204883	37	22	205068	63	8	208008-FD	7	19	208173	25	6
204691	130		204885	65	3	205069	63	10	208009	7	21	208192	13	11
204692A	133		204886	65	4	205070	63	14	208010	7	24	208194	29	14
204692A-BF	133		204887	65	5	205072	63	22	208023AHD	5	26	208195	29	15
204693	129		204888	59	9	205088	31	36	208025	29	1	208196	29	10
204693	131		204888	65	7	205091	59	38	208026	29	4	208215	124	
204694A	133		204889	65	10	205091	63	38	208027	29	3	208215	126	
204700	126		204890	65	11	205103	63	33	208028	29	6	208215	127	
204701	126		204891	65	13	205104	63	28	208029	29	7	208216	124	

INDEX

PART NO.	PAGE	NO. REF.	PART NO.	PAGE	NO. REF.	PART NO.	PAGE	NO. REF.	PART NO.	PAGE	NO. REF.	PART NO.	PAGE	NO. REF.
208217	125		208449	19	7	208730	130		209160	19	32	210124	27	16
208219	126		208449	21	7	208731	130		209161	19	16	210125	27	17
208218	124		208449	23	9	208732	130		209163-HD	5	27	210127	33	8
208219	124		208449	27	9	208733	130		209169	35	3	210128A	33	14
208219	126		208449	31	9	208734	130		209171	130		210129	33	9
208219	127		208450	19	5	208735	61	37	209173	39	24	210130	33	10
208220	125		208450	21	5	208735	130		209174	19	1	210136	33	25
208221	125		208450	23	7	208735	131		209174	21	1	210164	37	17
208222	124		208450	27	7	208737	9	19	209175	19	9	210184	39	37
208223	125		208476	11	9	208738	9	20	209195	127		210281	23	23
208224	124		208477	11	11	208740	9	22	209196	127		210281	27	15
208224	126		208481	5	3	208741	9	17	209197	127		210282A	33	13
208225	125		208482	5	4	208744	5	36	209198	127		210283	31	24
208225	126		208484	65	38	208747	5	35	209199	127		210284	31	23
208235	39	8	208486	49	9	208753	130		209200	57	2	210285	31	19
208245	9	42	208487	49	14	208753	131		209202	127		210287	31	17
208247	17	11	208500	124		208773	41	35	209204	127		210292	31	16
208248	17	9	208500	125		208774	41	34	209206	57	6	210294	29	11
208249	17	1	208501	124		208777	19	18	209209	131		210296	29	19
208250	17	10	208501	125		208777	21	16	209224	129		210297	23	17
208258	25	25	208502	124		208778	19	15	209225	133		210297	29	20
208260	47	23	208502	125		208782	51	19	209226	43	28	210319	19	6
208272	11	10	208503	124		208782	132		209226	129		210319	21	6
208273	37	1	208504	124		208783	51	20	209229-B	43	29	210319	23	8
208274	37	2	208504	125		208783	132		209230	43	24	210319	27	8
208275	37	3	208507	125		208802	5	8	209230	55	17	210319	31	8
208276	37	4	208507	126		208851	39	33	209232	43	23	210353	27	28
208284	35	5	208508	125		208883	126		209232	55	16	210529	19	11
208285	35	7	208508	126		208888	126		209250	25	1	210529	21	12
208286	31	20	208508	127		208891	45	6	209254	126		210530	27	3
208286	35	8	208509	125		208903	17	30	209255	126		210531	21	9
208292	23	16	208509	126		208904	130		209257	129		210531	23	3
208299-HD	5	1	208509	127		208905	130		209285	7	34	210584	128	
208307	19	13	208525-B	43	30	208905	131		209293	129		210584	129	
208307	21	14	208526	41	22	208905	132		209304	33	31	210584	130	
208308	49	1	208528-B	45	2	208906	130		209307	43	1	210584	131	
208313	41	11	208529	45	11	208906	131		209308	43	2	210584	132	
208314	41	13	208531	124		208907	131		209309	43	3	210585	43	39
208315	41	14	208531	125		208908	124		209311	43	6	210586	27	18
208316	41	5	208531	126		208908	125		209312	43	11	210586	29	21
208318	47	24	208531	127		208908	126		209313	43	14	210679	3	18
208322	131		208532	125		208909	124		209314	43	20	210679	3	27
208323	131		208532	126		208909	125		209324	53	9	210766	49	21
208324	131		208532	127		208909	127		209324	55	9	210930	19	47
208325	131		208534	41	21	208910	124		209325-BF	132		210930	21	47
208326	131		208535	41	19	208910	125		209326-BF	133		210936	59	7
208327	131		208537	41	36	208910	126		209327-BF	132		210937	59	17
208333	33	3	208547	43	42	208910	127		209327-BF	133		210938	59	35
208334	128		208549	41	24	208911	128		209328-BF	132		210939	59	37
208335	128		208554	51	23	208912	128		209330-BF	133		210940	59	30
208336	133		208554	73	1	208912	133		209333-TA	55	19	210944	59	33
208337	133		208560	19	22	208913	45	3	209333-TA	132		210945	59	15
208338	128		208560	21	20	208915	61	29	209334	55	23	210946	59	13
208338	133		208561	19	23	208916	61	33	209335	53	4	210947	59	11
208339	5	7	208561	21	21	208919	5	14	209335	55	4	210948	59	22
208341	5	18	208562	19	24	208921	5	17	209337	41	23	210952	59	27
208342	5	20	208562	21	22	208932-HD	11	1	209338	45	33	210953	59	2
208346	13	9	208563	19	25	208935	21	34	209355	132		210954	59	4
208346	13	13	208563	21	23	208937	25	2	209367A	13	1	210955	59	21
208346	15	10	208568	19	21	208938	25	18	209367B	13	2	210962	51	5
208346	15	13	208568	21	19	208944	33	30	209367C	15	1	210962	59	41
208362	31	35	208592	25	19	208945	7	5	209367D	15	2	211511	43	4
208399	19	19	208598	41	28	208949	33	33	209367E	15	3	211514	43	10
208400	21	17	208599	41	30	208951	13	3	209384-BF	133		211516	43	15
208401	7	27	208600AFD	3	24	208951	15	4	209386	131		211517	43	18
208402	39	11	208601AFD	3	25	208952	35	43	209387-30	131		211600	131	
208404	39	25	208602-FD	3	1	208955	126		209387-40	131		211613	59	34
208411	33	19	208603-FD	3	5	208958-B	45	5	209388-25	131		211614	59	24
208412	33	21	208604	7	14	208958-B	45	14	209388-35	131		211771	131	
208413	33	20	208610	9	1	208965	126		209388-45	131		211802A	33	16
208415	33	24	208611	9	7	208966	126		209389-91Y	25	12	211804	33	17
208421	33	32	208612	9	6	208974	25	14	209402-91	61	28	211806	33	27
208424	17	12	208616	17	28	208976	25	13	209405	9	28	211807	33	26
208425	17	15	208617	17	27	208978	45	19	209407	47	10	211873-TA	53	16
208427	17	24	208621	17	19	208979	23	25	209408	47	19	211873-TA	132	
208429	23	18	208625	35	47	208980	25	8	209409	47	20	211874-TA	132	
208430	7	3	208648	126		208981	27	31	209410	47	16	211875 TA	132	
208434	3	8	208649	126		208993	127		209411-91	49	27	211876	53	18
208445	23	24	208651	130		208994	57	1	209412-91	49	28	211877	53	19
208446	49	10	208658	59	1	208997	57	4	209415-16	131		211879	53	3
208447	19	2	208659	59	3	208998	127		209416-16	133		211879	55	3
208447	21	2	208660	59	5	209000	57	5	209417-16	131		211880	53	1
208447	23	4	208674	126		209007	27	24	210003	3	13	211880	55	1
208447	27	4	208675	126		209009	19	45	210003	3	21	211885	51	1
208447	59	28	208676	126		209009	21	45	210005	3	11	211886	51	2
208448	19	3	208693	39	10	209009	130		210007	7	12	211895-TA	55	20
208448	21	3	208713	19	26	209009	131		210025	9	2	211897-B	55	21
208448	23	5	208713	21	24	209009	132		210067	39	5	211902	55	22
208448	27	5	208725	5	34	209068	17	46	210107	25	15	211904	45	35
208448	59	29	208730	61	39	209159	19	38	210109	25	3	211905	45	31

INDEX

PART NO.	PAGE	NO. REF.	PART NO.	PAGE	NO. REF.	PART NO.	PAGE	NO. REF.	PART NO.	PAGE	NO. REF.	PART NO.	PAGE	NO. REF.
211915	45	26												
211916	45	27												
211917	45	28												
211918	45	33												
211919	45	22												
211920	45	35												
211944	43	32												
211946	53	2												
211946	55	2												
211949	55	29												
212186	17	23												
212271-TA	132													
212280A	3	17												
212978-91	47	12												
212981	47	13												
212982A	47	14												
230047A	3	26												
240102	11	27												
240102	23	22												
240102	27	19												
240162	3	22												
240178	49	19												
300248	45	30												
303067	57	13												
303312A	61	26												
303313	61	27												
303688	61	40												

■ PEGASUS
SEWING MACHINE MFG.
CO., LTD.®

